

DEUBLIN

HOERBIGER Rotary Solutions

MPSS151 US



MULTI-PASSAGE SOFT-SEAL ROTATING UNIONS

www.deublin.com

DEUBLIN Multi-Passage Soft-Seal Rotating Unions

A rotating union connects a stationary pressurized supply line to a rotating machine part such as a cylinder, roll, spindle, clutch, etc. It can be used to convey virtually any liquid or gas: steam for heating, water or water/glycol solutions for cooling, hydraulic fluids, cutting fluids, air, inert gas, or even vacuum. The task becomes more complicated when more than one media must be conveyed simultaneously. This is the role of a multi-passage union – to provide multiple, independent passages for the same or several different media to different rotating feed points within the same axis.

Typically, each passage is isolated from all other passages and different media are not allowed to mix. The key to reliable function of a multi-passage union thus lies in the sealing technology. Different seal types are dictated by the operating conditions – temperature, pressure, rotation speed, torque, medium chemistry and passage size.

Because each application is unique in terms of passage diameter, number of passages, flange configuration and operating conditions, Deublin brings to bear unparalleled engineering expertise and experience to match your operational needs. Whether a standard model can be applied or a custom solution is required, you can rely on Deublin for the optimal solution with long-term performance and reliability.

TYPICAL APPLICATIONS FOR MULTI-PASSAGE UNIONS

- Steel industry: ladle turrets for continuous casting operations
- Plastics & rubber industries: injection and rotary molding operations
- Machining operations: workholding and clamping functions
- Aerospace manufacturing and flight simulators
- Industrial cranes
- Rail transportation
- De-scaling operations
- ...and many more



Deublin Multi-Passage unions testing fixture

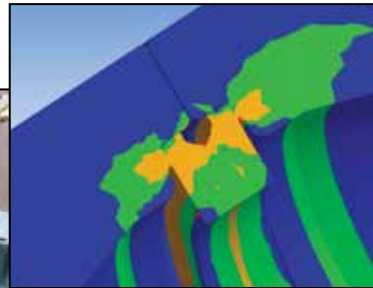

Designed and engineered with
Finite Element Analysis (FEA),
and validated by extensive
testing

DEUBLIN Multi-Passage Sealing Solutions

Deublin multi-passage soft-seal unions are optimized for the operating parameters of the application such as speed, torque, media pressure, operating temperature, physical size and other factors. Hardened chrome sealing surfaces are standard to ensure minimal wear and long service life.

- **Plastomeric Seals** – a combination of plastic and elastomer – offer superior resistance to high temperatures and pressures compared to traditional elastomers. Seal geometry and treatment of the rotor mating surface are carefully matched to the media, rotational speed, and pressure of the specific application.
- Deublin's proprietary seal chemistry and geometry maximize performance including reduced friction and torque, and extended service life. This performance advantage allows Deublin multi-passage soft-seal unions to be used for a wide variety of applications.

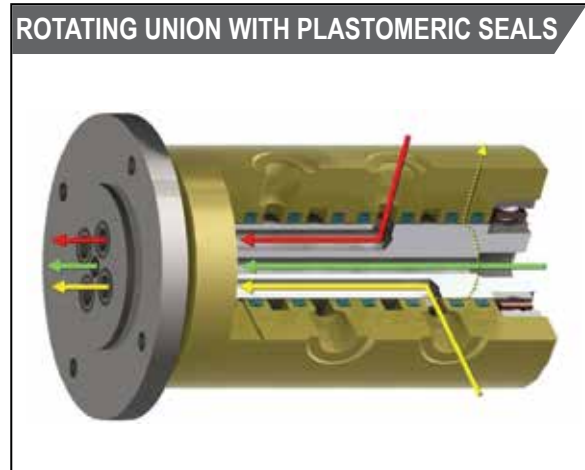

Typical commercial seal design:

Inner pad may have different cross-sectional geometry depending on media and operating conditions.



Deublin proprietary seal design:

Use a variety of materials and geometries depending on media and operating conditions.

DEUBLIN Product Definition

Deublin multi-passage soft-seal rotating unions can be used in the widest variety of applications and media. Typical media includes the following:

- Hydraulic Oil
- Water
- Water-Glycol
- Air (dry/lubricated)
- Nitrogen
- Argon
- Grease
- Coolant
- Cutting Oil
- Vacuum

For media not listed above, please contact Deublin.

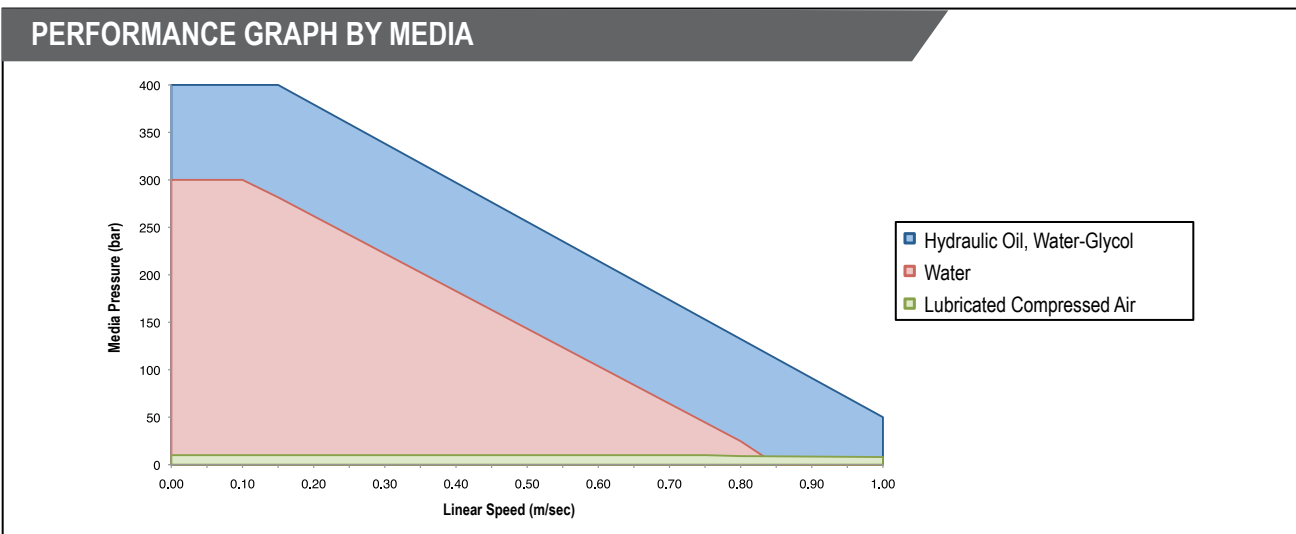

TYPICAL MEDIA & OPERATING CONDITIONS

Media	Pressure		Temperature		Speed
	bar	psi	°C	°F	
Hydraulic Oil	≤ 400	≤ 5,800	≤ 80	≤ 175	Maximum rotational speed is a function of media, pressure and rotor diameter (see above chart). Note: Typical speeds ≤ 50 RPM
Water-Glycol	≤ 400	≤ 5,800			
Water	≤ 300	≤ 4,350			
Air (dry/lubricated)	≤ 12	≤ 175			
Nitrogen	≤ 12	≤ 175			
Argon	≤ 12	≤ 175			
Coolant	≤ 120	≤ 1,740			

For operating conditions exceeding above parameters, please contact Deublin.

WARNING DEUBLIN unions should not be used to convey flammable media (flash point ≤ 140°F or 60°C) as leakage may result in explosions or fires. DEUBLIN unions should be used in accordance with standard safety guidelines for the media, and in a well-ventilated area. The use of our product on hazardous or corrosive media is strictly forbidden.

DEUBLIN Product Definition

Deublin offers Multi-Passage Soft-Seal rotating unions that are standard, semi-custom and custom. When possible, Deublin recommends standard models, but will recommend semi-custom or custom models depending on the unique requirements of each application.

Semi-Custom unions can have different port sizes on the same union, SAE port connections and/or larger center bore (up to 50 mm).

Custom unions have no limitation on dimensions, port sizes, port connection specifications and center bore dimensions.

STANDARD FEATURES

- Ports/Passages: 2 to 8
- Sizes: 1/8" to 1/2", NPT or BSP
- Materials of Construction:
 - Flanged rotor: AISI 420 with aluminum housing
 - Bearings: dual, widely-spaced ball bearings ensure smooth running and minimize impact of potential side-loading
- Optional center bore up to 25 mm (1") for electrical slip ring wires

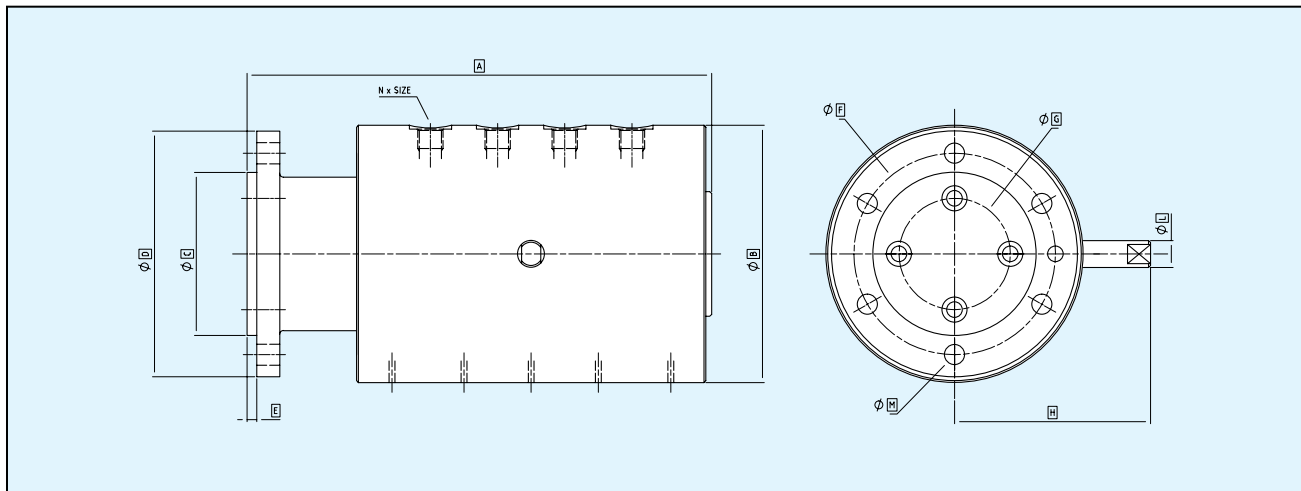

	Port Size 1/8" – 1/4"				Port Size 3/8" – 1/2"				
	2	4	6	8	2	4	6	8	
A	160	245	315	385	A	165	270	356	440
B	110	135	155	155	B	120	135	155	155
C	73	85	105	105	C	73	85	105	105
D	110	128	152	152	D	110	128	152	152
E	5	5	7	7	E	5	5	7	7
F	93	105	128	128	F	93	105	128	128
G	44	58	78	78	G	38	53	73	73
H	90	115	130	130	H	95	115	130	130
L	12	14	16	16	L	12	14	16	16
M	9	11	13	13	M	9	11	13	13
Unions Also Available With Central Bore					Unions Also Available With Central Bore				
Max Ø	25	40	50	50	Max Ø	12	25	45	45

Note: all dimensions, except port sizes, in mm

Examples of Applications

Deublin designs and manufactures a complete range of rotating unions from simple, single channel models used to prevent flex-hoses from twisting, to 12-port unions used on machine tool index tables, to massive, multi-channel unions used for ladle turrets in continuous casting machines. Deublin Multi-Passage Soft-Seal unions are used in applications that may require air, water, oil, grease, argon and other media.



Application: Machine Tool
Passages: 12

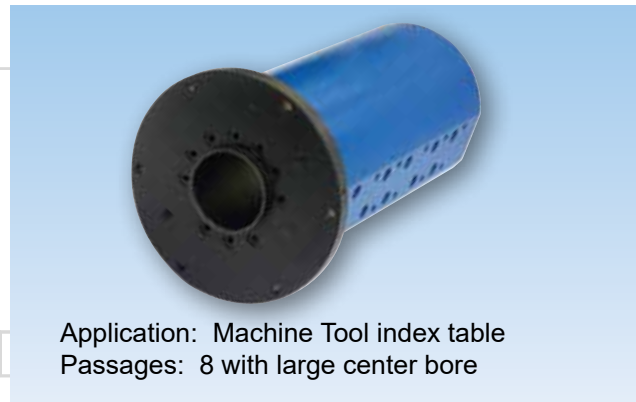

Application: Machine Tool index table
Passages: 8 with large center bore

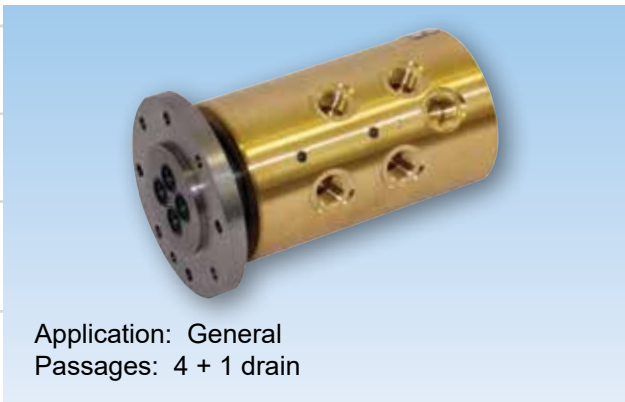

Application: General
Passages: 4 + 1 drain



Application:
Ladle Turret
Passages: 22

Examples of Applications



Application: Index Table
Passages: 16

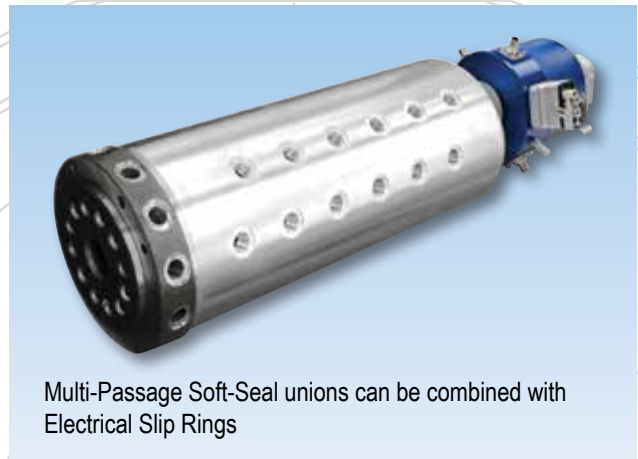

Multi-Passage Soft-Seal unions can be combined with
Electrical Slip Rings



Application: Steel Plant
Passages: 5 with large center bore



Application: Coil Winding
Passages: 6

Since its founding in 1945 as a small, family-owned business, Deublin consistently has adhered to a policy of designing and building the best products of their kind in the world. The result of this policy has been constant growth through the years, and for this we are grateful to our many loyal customers.

Today, Deublin is the world's largest manufacturer of rotating unions, with state-of-the-art factories, technical sales and service, and local stocking in 15 countries on four continents, as well as a worldwide distribution network operating from more than 60 countries. Our global organization and extensive catalog of field-tested products ensure a precise match between each customer's requirements and an engineered solution.

We cordially invite you to visit our modern manufacturing facilities in Waukegan, Illinois, USA; Mainz, Germany; Monteveglio, Italy; Dalian, China; and Sao Paulo, Brazil.



Global Headquarters in Waukegan, Illinois, U.S.A.



Mainz, Germany



Monteveglio, Italy



Dalian, China



Deublin products & services are available throughout the world.

www.deublin.com

AMERICAS

DEUBLIN USA

2050 Norman Drive
Waukegan, IL 60085 U.S.A.
Phone: +1 847 689-8600
Fax: +1 847 689-8690
e-mail: cs@deublin.com

DEUBLIN Brazil

Rua Fagundes de Oliveira, 538 - A11 –
Piraporinha
CEP: 09950-300 - Diadema - SP – Brazil
Phone: +55 11-2455-3245
Fax: +55 11-2455-2358
e-mail: deublinbrasil@deublinbrasil.com.br

DEUBLIN Mexico

Norte 79-A No. 77, Col. Claveria
02080 Mexico, D.F.
Phone: +52 55-5342-0362
Fax: +52 55-5342-0157
e-mail: deublinmexicocscs@deublin.com

ASIA

DEUBLIN China

No. 2, 7th Street, DD Port,
Economic Development Zone, Dalian,
Liaoning Province, 116620, P.R. China
Phone: +86 411-87549678
Fax: +86 411-87549679
e-mail: info@deublin.cn

Room15A07, Wangjiao Plaza
No.175 East Yan'an Road, Huangpu District
Shanghai, 200041, P.R. China
Phone: +86 21-52980791
Fax: +86 21-52980790
e-mail: service@deublin.cn

DEUBLIN Asia Pacific

51 Goldhill Plaza, #17-02
Singapore 308900
Phone: +65 6259-9225
Fax: +65 6259-9723
e-mail: deublin@singnet.com.sg

DEUBLIN Japan

2-13-1, Minamihanayashiki
Kawanishi City 666-0026, Japan
Phone: +81 72-757-0099
Fax: +81 72-757-0120
e-mail: customerservice@deublin.jp

2-4-10-3F Ryogoku
Sumida-Ku, Tokyo 130-0026, Japan
Phone: +81 35-625-0777
Fax: +81 35-625-0888
e-mail: customerservice@deublin.jp

1-9-2-4F Mikawaanjo-cho
Anjo City, Aichi 446-0056, Japan
Phone: +81 566-7361
Fax: +81 566-71-4360
e-mail: customerservice@deublin.jp

DEUBLIN Korea

Star Tower #1003, Sangdaewon-dong 223-25,
Jungwon-gu, Seongnam-si, Gyeonggi-do,
South Korea
Phone: +82-31-8018-5777
Fax: +82-31-8018-5780
e-mail: customerservice@deublin.kr

EUROPE

DEUBLIN Germany

Florenz - Allee 1
55129 Mainz, Germany
Phone: +49 6131-4998-0
Fax: +49 6131-4998-109
e-mail: info@deublin.de

DEUBLIN Italy

Via Guido Rossa, 9
40053 Comune di Valsamoggia (BO), Italy
Phone: +39 051-835611
Fax: +39 051-832091
e-mail: info@deublin.it

DEUBLIN Austria

Mitterfeldgasse 3/18/R02
1110 Vienna, Austria
Phone: +43 1-8768450
Fax: +43 1-876845030
e-mail: info@deublin.at

DEUBLIN France

61 bis, Avenue de l'Europe
Z.A.C de la Malnoue
77184 Emerainville, France
Phone: +33 1-64616161
Fax: +33 1-64616364
e-mail: service.client@deublin.fr

DEUBLIN Poland

ul. Bierutowska 57-59
51-317 Wroclaw, Poland
Phone: +48 71-3528152
Fax: +48 71-3276278
e-mail: info@deublin.pl

DEUBLIN Russia

5-ya Sokoloini gori, 18, bld. 2, office 1
105275, Moscow, Russia
Phone: +7 495 647-14-34
Fax: +7 495 938-89-49
e-mail: info@deublinrussia.ru

DEUBLIN Spain

C/Lola Anglada, 20 local 1,
08228 Terrassa, Spain
Phone: +34 93-2211223
Fax: +34 93-2212093
e-mail: deublin@deublin.es

DEUBLIN United Kingdom

6 Sopwith Park, Royce Close,
West Portway
Andover SP10 3TS, UK
Phone: +44 1264-333355
Fax: +44 1264-333304
e-mail: info@deublin.co.uk