

# DEUBLIN

*HOERBIGER Rotary Solutions*



## ROTATING UNIONS

For Machine Tools, Machining Centers and Transfer Lines

# 4 STEPS TO FINDING THE CORRECT UNION SERIES FOR YOUR MACHINE TOOL APPLICATION

- 1 Does the machine have a single supply connection (for example, coolant) or multiple connections (such as a combination of coolant, air, and hydraulic oil)?
- 2 What fluid or fluids must be transferred by the rotating union?
- 3 What is the maximum pressure required?
- 4 What is the maximum spindle speed required?

1 No of Inputs	2 Fluid(s) to Transfer	3 Max. Pressure	4 Maximum Speed (rpm)				
			up to 12,000	up to 15,000	up to 20,000	up to 36,000	over 36,000
Single	Coolant or MQL (always present during rotation)	up to 105 bar	1116 series (p. 13) up to 70 bar	1101 series (p. 12) 1005 series (p. 11)	Contact DEUBLIN		
		up to 200 bar	1117 series (p. 24)				
		up to 210 bar	1108 series (p. 14-15, 23)			Contact DEUBLIN	
	Coolant or MQL - dry run possible - (rotation with no coolant is possible)	up to 150 bar	902 series (p. 20) up to 70 bar	1109 series (p. 16, 17)			
			1121 series (p. 26), 1151 series (p. 28)				
	Coolant or MQL or Compressed Air - dry run possible - (operation without coolant possible)	up to 150 bar	1114 series (p. 18, 19, 23)			Contact DEUBLIN	
			1124 series (p. 27), 1154 and 1139 series (p. 29, 30), 1159 (p. 31)				
Compressed Air only (and Vacuum – 7000 series)	up to 10 bar	1115 and 7000 series (p. 21) up to 18,000 rpm			Contact DEUBLIN		
Multipassage Hydraulic, Coolant, Lubricant, MQL, Compressed Air (for defined dry run cycles)	up to 70 bar	1005 and 1101 series (p. 22) up to 10,000 rpm 1116 series (p. 22)	Contact DEUBLIN				
No of Inputs	Fluid(s) to Transfer	Max. Pressure	up to 7,000	up to 12,000	over 12,000		
Multiple	Hydraulic Oil + Hydraulic Oil	up to 100 bar	2620-00x-xxx (p. 34)		Contact DEUBLIN		
		up to 140 bar	2620-04x-xxx (p. 35)				
	Hydraulic Oil + Compressed Air	up to 40 bar	2620-30x-xxx 2620-32x-xxx (p. 34)				
		up to 70 bar	2620-10x-xxx 2620-12x-xxx (p. 34)	2620-34x-xxx 2620-36x-xxx (p. 35)			
		up to 140 bar	2620-14x-xxx, 2620-16x-xxx (p. 35)				
	Coolant or MQL + Compressed Air	up to 40 bar	2620-40x-xxx 2620-42x-xxx (p. 34)				
		up to 70 bar	2620-20x-xxx 2620-22x-xxx (p. 34)	2620-44x-xxx 2620-46x-xxx (p. 35)			
		up to 140 bar	2620-24x-xxx 2620-26x-xxx (p. 35)				
	Coolant + Hydraulic Oil (no mixture of fluids)	up to 140 bar	2630-1xx-xxx (p. 35) up to 10,000 rpm				
	Compressed Air + Compressed Air	up to 10 bar	2620-5xx-xxx (p. 34)				
Coolant + Oil + Compressed Air	up to 140 bar	2630, 2640, 2650 series (p. 36) up to 10,000 rpm					
Multipassage Hydraulic, Coolant, Cooling Water, MQL, Compressed Air, Vacuum	up to 200 bar	260x (p. 37) hybrid-multi-channel series up to 2,500 rpm (p. 38)					

Bearing-supported (one-piece) unions
  Bearingless (two-piece) unions
  Multi-passage unions

**SUBJECT TO BOTH TECHNICAL AND DIMENSIONAL CHANGES WITHOUT PRIOR NOTICE – UNLESS SPECIFICALLY TOLERANCED ALL DIMENSIONS ARE FOR REFERENCE. ALL DIMENSIONS IN MM, EXCEPT AS NOTED OTHERWISE.**

# HOW TO GET THE MOST VALUE FROM THIS CATALOG

If you are less familiar with machine tool applications of rotating unions, or if you would like a quick review, please read the “Information” sections first. These sections contain important details about designing, installing, and using rotating unions in machine tools.

If you understand the principles of designing machines to use rotating unions completely, please use either the Selection Chart on the inside cover or Table of Contents to find the appropriate product page. These pages contain dimensions, performance data, and other necessary application information.

If you don't see what you need, please contact your local DEUBLIN office directly. Telephone, email, and address information are shown on the back cover of this catalog. Unions in this catalog are representative of most common applications, but other variations are available. Deublin can customize the interface between machine and union, such as hose connections or rotor threading, to your specifications. Also, Deublin easily can develop complete unions to meet special pressure, speed, or media requirements.

*“If you don't see it, we probably have it.  
If we don't have it, we can create it.”*



DEUBLIN 1109 on vertical machining center

# TABLE OF CONTENTS

## Information for Designers of Machine Tools

Operating Principles of Rotating Unions . . . . .	4
Selecting the Right Rotating Union for Your Application . . . . .	5, 6
Mounting Tolerances . . . . .	7
Drain and Supply Hose Connections . . . . .	8

## Information for Users of Machine Tools

Installation Techniques . . . . .	9
Coolant Filtration and Maintenance . . . . .	10
Thread Equivalence . . . . .	10

## Bearing-Supported Unions

“Closed Seal” Designs – when media is always present during rotation 1005, 1101, 1116, 1108 . . . . .	11-15
Pop-Off® Designs – when rotation without media is possible 1109 . . . . .	16-17
AutoSense® Designs – when both coolant and pressurized dry air are used interchangeably 1114 . . . . .	18-19
Pop-Off® Designs – when rotation without media is possible 902 . . . . .	20
“Controlled Leakage” Designs – for unlimited operation with pressurized dry air 1115, 7000 . . . . .	21
1-Passage Design for various media combinations 1005/1101/1116 . . . . .	22
Flange design 1114, 1108 . . . . .	23

## Bearingless Unions

“Closed Seal” Designs – when media is always present during rotation 1117 . . . . .	24
Compact bearingless cartridge models . . . . .	25
Pop-Off™ Designs – when rotation without media is possible 1121, 1151 . . . . .	26, 28
AutoSense™ Designs – when both coolant and pressurized dry air are used interchangeably 1124, 1154 . . . . .	27, 29
“All-Media” Designs 1139, 1159 . . . . .	30-31

## Multi-Passage Unions

2-passage designs for various media combinations 2620 . . . . .	34-35
3-passage to 5-passage designs for various media combinations 2630, 2640, 2650, 2603, 2604, 2606, 2608 . . . . .	36-37
Up to 10-passages hybrid-multi-passage design for various media combinations . . . . .	38
1379, 1479 . . . . .	39

## Spindle Protection Unions

SpindleShield Series Unions with Integrated Alert System for Spindle Protection 1103, 1113, 1153 . . . . .	40
---	----

## General Information

Warranty and other important information . . . . .	41
Getting technical or design assistance from DEUBLIN . . . . .	42
DEUBLIN offices and contact information . . . . .	Back Cover

Please see page 6 for further explanations to the individual series.



# INFORMATION FOR DESIGNERS OF MACHINE TOOLS

## OPERATING PRINCIPLES OF ROTATING UNIONS

### Advantage of Through-Spindle Coolant (TSC)

Nearly all modern machine tools and machining centers are equipped with so-called "flood coolant". High-speed cutting tools require both cooling and lubrication to reduce the rate of tool wear and to prevent overheating, which degrade the tool's strength. Flood coolant systems spray coolant fluid onto the work piece near the cutting tool. But for many machining operations, such as milling or hole drilling, these systems are less effective at getting coolant fluid to the cutting edge.

Without coolant, the flutes of the cutting tool can become packed with chips and the cutting edge loses hardness due to overheating. This leads to excessive wear and short tool life. Poor chip removal also can cause a poor surface finish on the work piece.

In machining centers with through-spindle coolant (TSC), coolant fluid is conducted directly through the cutting tool to cool the cutting edge, reduce friction, and remove chips. Coolant flows axially through a rotating union into the spindle and tool holder directly to the heat source. Compared to flood coolant systems, TSC pays for itself in terms of lower operating costs for tools and coolant. Better control of tool overheating also allows faster feed rates and higher productivity.

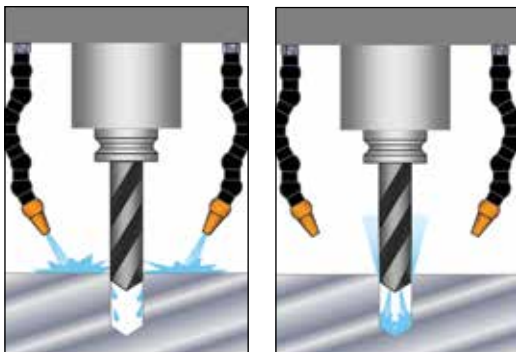

Flood Coolant

Through-Spindle Coolant

### How Rotating Unions Work

A rotating union is a precision mechanical device used to transfer coolant fluid or media from a stationary source, such as a pump, into a rotating device, such as a spindle with cutting tool. The typical coolant fluid is water-based, consisting of approximately 85-95% water for cooling, 2-12% oil for lubricating the cutting edge, and a small amount of other chemicals for keeping the water and oil mixed and for other purposes. Deublin Rotating Unions also can transfer air/oil mist, known as Minimum Quantity Lubrication (MQL), cutting oils, and even dry air. The exact capabilities vary by model number, so please consult the product pages of this catalog for details.

In certain machine tool applications, rotating unions also are used to transfer hydraulic fluid or air for clamping or sensing.

### Parts of a Rotating Union

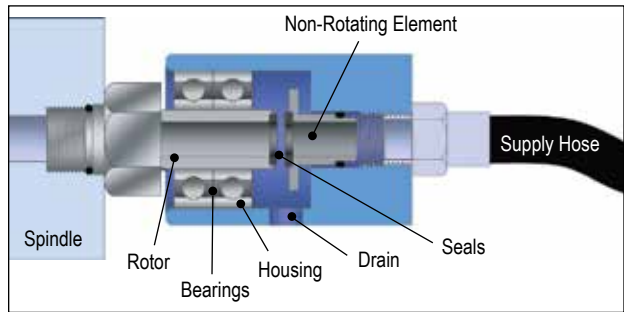

As shown in the picture above, a typical rotating union consists of a rotor that spins at the same speed as the machine tool spindle, a non-rotating element that closes precisely against the rotor, a housing that connects the supply hose to the non-rotating element, and seals that contain the coolant fluid. Bearing-supported unions connect the rotor to the housing with one or more bearings. Bearingless unions omit these bearings. Depending on the application, the housing may have one or more drain connections.

Seals are the heart of the rotating union. They must contain very high pressures while rotating at very high speeds. At 20,000 rpm, for example, the seals of a Deublin 1129 series coolant union are moving at a relative speed of nearly 16 feet per second (5 meters per second), while containing 2030 psi (140 bar) of fluid pressure!

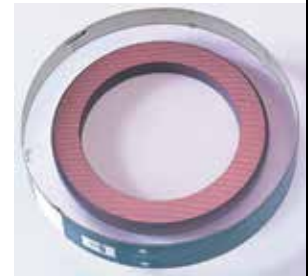

Micro-lapped Deublin seal

For positive sealing, smooth rotation, and long service life, all DEUBLIN seals are micro-lapped with proprietary machines and compounds to achieve an optical flatness of 2 light bands (23 millionths of an inch, or 0.58 microns). In addition, all Deublin coolant unions use seals made from special grades of silicon carbide. Deublin seals therefore have superior resistance to wear and heat accumulation, compared to lesser materials.

Finally, Deublin Rotating Unions are designed with balanced mechanical seals. With this technology, seal contact pressure and thrust load on the spindle are minimized, regardless of operating pressure. This reduces seal wear even further, resulting in longer life and more reliable performance.

DEUBLIN Balanced Mechanical Seal  
Partial line pressure is applied to seal face.

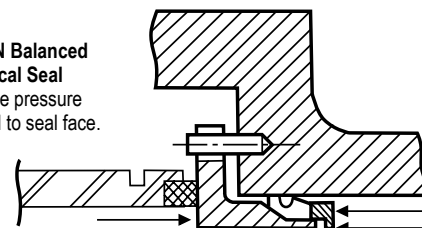

# INFORMATION FOR DESIGNERS OF MACHINE TOOLS

## SELECTING THE RIGHT UNION FOR YOUR APPLICATION

### Bearing-supported Rotor-mounted



Example: DEUBLIN 1109 series

### Bearing-supported Bore-mounted



Example: DEUBLIN 1109 series

### Bearingless



Example: DEUBLIN 1139 series

### Bearing or Bearingless?

Rotating unions for machine tool applications are available in bearing-supported and bearingless configurations. Each kind has advantages and disadvantages for the machine tool designer.

**Bearing-supported unions** are easy to install and replace, because of their one-piece design. Deublin makes two different mounting styles. The **rotor-mounted** style attaches to the machining center with a threaded rotor. The **bore-mounted** style slides into a precisely machined counterbore at the end of the spindle. A second advantage of both styles is that any leakage is channeled by the housing into a drain line. A third advantage is that rotor-mounted, bearing-supported unions absorb nearly all axial forces (thrust load) on the spindle caused by coolant pressure. For both bore-mounted and bearingless unions, however, coolant pressure creates a certain thrust load on the spindle.

**Bearingless unions** provide the machine tool designer with several advantages. First, eliminating bearings reduces cost while allowing an increase in maximum rpm. Second, since only a small rotor is directly attached to the spindle, there is no possibility for the union's housing to be a source of vibration. Third, without bearings the union is immune to side loading from, for example, too much tension in the coolant supply hose. Fourth, bearingless unions can be very small, ideal for applications with multiple, closely spaced spindles. However, bearingless unions must be installed in two pieces – the rotor and a small housing containing the non-rotating element and connection to the coolant supply. So, during installation, the micro-lapped seal faces are exposed and must be handled carefully.



DEUBLIN 1116 Bearing-Supported Unions on Automotive Transfer Line



DEUBLIN 1117 Bearingless Unions on Automotive Transfer Line

# INFORMATION FOR DESIGNERS OF MACHINE TOOLS

## SELECTING THE RIGHT UNION FOR YOUR APPLICATION

### Which DEUBLIN® Seal Technology?

Deublin offers **five** different seal technologies, in order to provide the best solution for every machining application. Only Deublin can offer such flexibility to the machine tool designer.

**Closed Seal:** As the name indicates, the seals stay closed with or without coolant pressure. Therefore, drain lines generally are not required. However, all rotating unions operate with a thin film of media between the seals. Over time, small, nearly invisible quantities of media can migrate across the seal faces. Therefore, proper venting provisions should be made. Closed seal unions generally are less affected by extremely contaminated coolant than other designs. However, closed seal unions should not be rotated for an extended time if coolant fluid is not present.

**Controlled Leakage:** The opposite of closed seals, controlled leakage seals always have a small gap between the seals, even when pressure is applied. For this reason, controlled leakage unions are excellent for high-speed applications with pressurized dry air. Controlled leakage unions generally are not suitable for coolant fluid applications.

**Pop-Off®:** This kind of seal closes only when pressure is applied. When pressure is removed, the seal faces separate by a very small distance. This eliminates friction and seal wear during operation without coolant, and therefore allows unlimited “dry running” at high speeds. Pop-Off® designs should be considered when machining will occur with and without through-spindle

coolant (TSC). Because the seals separate during tool changes when coolant pressure is off, residual coolant in the supply hose and spindle can drain through the seal faces. Therefore, a Pop-Off® union generally requires a downward-pointing drain line to direct such residual coolant into the sump. Also note that Pop-Off® unions are not intended for extended operation with pressurized dry air.

**AutoSense®:** The latest in a series of DEUBLIN innovations, this technology combines the best features of Pop-Off® and controlled leakage designs. Like Pop-Off® designs, AutoSense® seals close when coolant pressure is applied to contain the coolant fluid, and “pop” apart in the absence of coolant pressure to allow unlimited dry running. Like controlled leakage designs, AutoSense® seals handle pressurized dry air by creating a microscopic gap between the seal faces. AutoSense® unions handle coolant, MQL, and dry air by sensing the kind of media and automatically changing seal operation in response. As with Pop-Off® seals, a drain line generally is required.

**All-Media:** This technology gives the machine designer complete control over seal opening and closing. By controlling how the pressure is applied to the union’s multiple connections, the machine designer can cause the seals to separate when necessary (for example, to transfer pressurized dry air) or close when appropriate (to transfer coolant fluid or oil mist). A drain line generally is required.

The table below summarizes the operation of each seal technology with different media.

Media	Seal Technology				
	Closed Seal (1005, 1101, 1108, 1116, 1117 Series)	Pop-Off® (902, 1109, 1121, 1151 Series)	All-Media (1139 Series)	AutoSense® (1114, 1124, 1154, 1159 Series)	Controlled Leakage (1115, 7000 Series)
No pressure	Dry run possible depending on model	Seals open automatically to prevent dry running			
Pressurized air		Not recommended with rotation	Micro-gap between seals to prevent dry running		
MQL	Seals are closed				
Coolant					

Deublin engineers can help you choose the best technology for your application.

# INFORMATION FOR DESIGNERS OF MACHINE TOOLS

## MOUNTING TOLERANCES

The interface between spindle and union must be manufactured to precise tolerance to ensure accurate, vibration-free operation. Bearingless unions and rotor-mounted, bearing-supported unions

require the spindle end to be machined according to the following dimensions and tolerances:

### Table shows reference data:

Please refer to the dimensions on the individual drawing when dimensioning the spindle.

Rotor Connection			Rotor Pilot		Spindle End			Tightening Torque
A	F	H	I	M	X	Y	Z	
5/8"-18 UNF	9/16"	15/16"	0.6555" / 0.6553"	3/16"	0.6560" / 0.6556"	9/32"	13/16"	35 Nm
5/8"-18 UNF	9/16"	15/16"	0.6249" / 0.6246"	3/32"	0.6254" / 0.6250"	3/16"	9/16"	35 Nm
M16 x 1.5	11	24	17.993 / 17.988	5	18.000 / 17.995	8.5	17	35 Nm
M16 x 1.5	11	24	16.025 / 16.020	5	16.037 / 16.027	7	17	35 Nm
M14 x 1.5	12	24	14.494 / 14.486	5	14.508 / 14.500	7	18	25 Nm
M12 x 1.25	11	24	13.994 / 13.989	5	14.005 / 14.000	7	17	15 Nm
M12 x 1 / M12 x 1.25	13	15	12.994 / 12.989	6	13.005 / 13.000	9	23	15 Nm
M10 x 1	11	17	10.994 / 10.989	3	11.008 / 11.000	5.2	15	10 Nm
M8 x 1	12.5	15	8.995 / 8.991	3.5	9.006 / 9.000	6	18	4 Nm

All dimensions in millimeters unless otherwise indicated.

### Spindle End

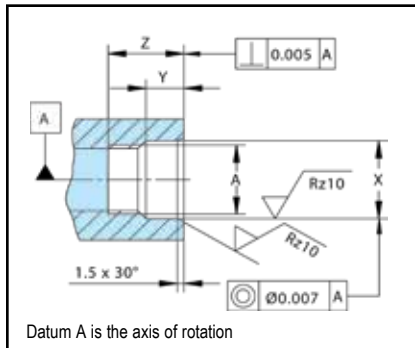

### Rotor End

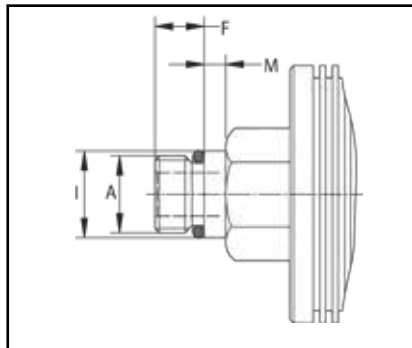

### Installed Rotor

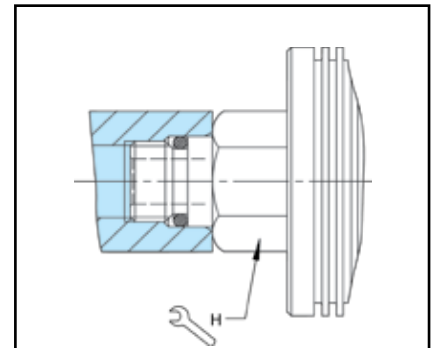

Bore-mounted, bearing-supported unions require one of the following two interfaces:

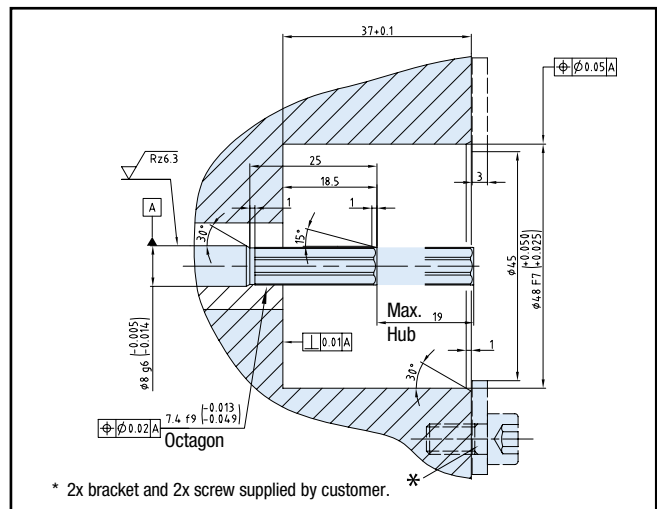
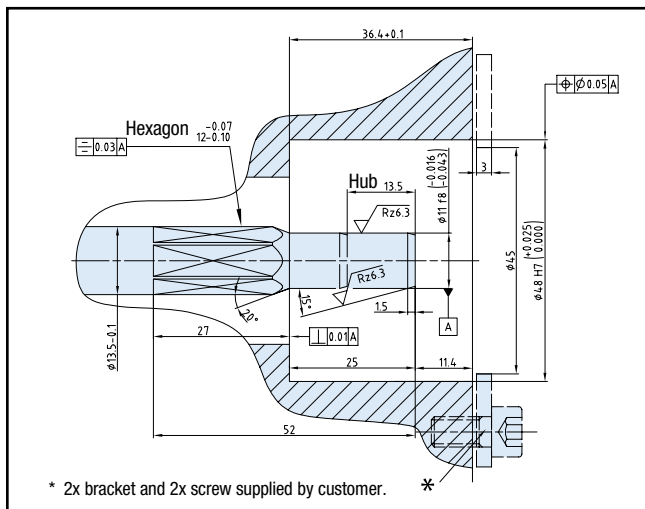



# INFORMATION FOR DESIGNERS OF MACHINE TOOLS

## DRAIN AND SUPPLY HOSE CONNECTIONS

### Drain Connection

All unions, even closed-seal designs, can experience migration of minimal amounts of media across the seal faces. Such media migration keeps the seals well lubricated and avoids the permanent seal damage that comes from dry running. In addition, even the best unions eventually will need replacement. Therefore, the machine tool designer should provide adequate drainage to prevent costly spindle damage.

Deublin designs are very advanced, but even Deublin must obey the law of gravity! Therefore, it is critical that all drainage hoses and paths slope downward continuously, as shown in the diagrams to the right.

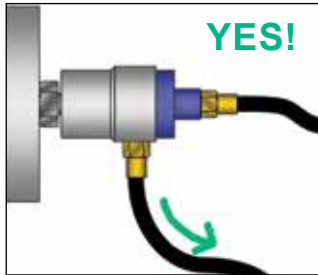

Drain hose always slopes downward

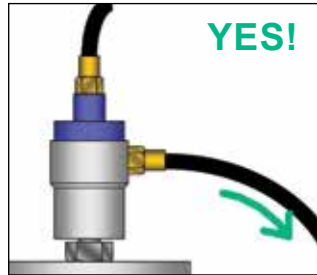

Drain hose always slopes downward

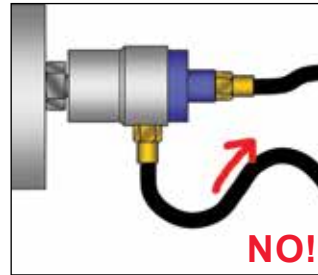

Part of drain hose slopes up

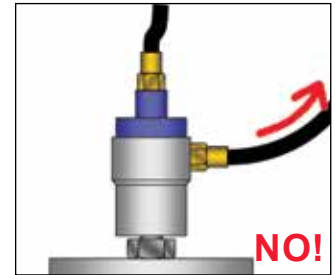

Drain hose slopes up from union

### Supply Connection

Deubli Pop-Off®, AutoSense®, and All-Media unions offer unlimited “dry running” at high speeds. By allowing the seal faces to separate when coolant pressure is removed, seal wear during unpressurized operation is completely eliminated. One consequence is that the seals separate during tool changes,

allowing residual coolant in the supply hose and spindle to drain through the seal faces. Careful orientation of the coolant supply hose can dramatically reduce this effect, as shown in the diagrams below.

### Supply Hose Slopes Down From Union

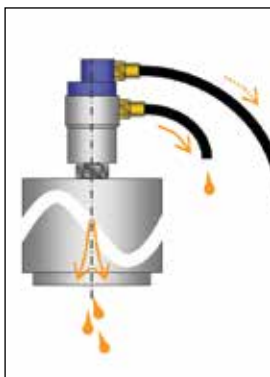

Tool change with vertical spindle

When the supply line runs down from the rotating union, any coolant between union and control valve will remain in the hose during tool change. This reduces the amount of drainage from both the spindle nose and the union drain line.

### Supply Hose Slopes Up From Union



Tool change with vertical spindle

When the supply line runs up from the rotating union, any coolant between union and control valve will flow down during tool change. This increases the amount of drainage from both the spindle nose and the union drain line.

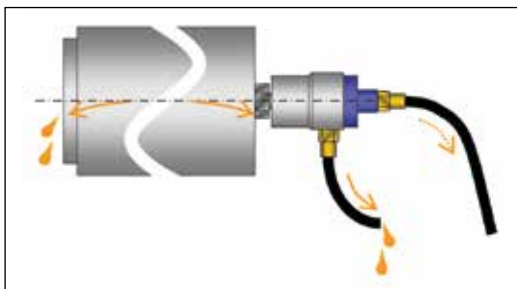

Tool change with horizontal spindle

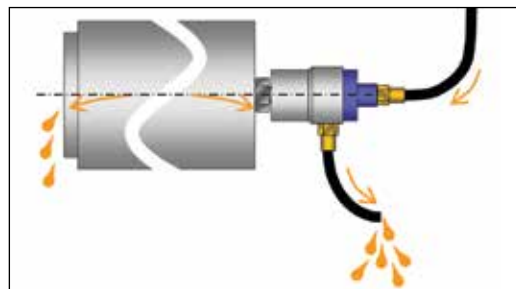

Tool change with horizontal spindle



# INFORMATION FOR USERS OF MACHINE TOOLS

## INSTALLATION TECHNIQUES

Installing a Deublin rotating union is as easy as 1-2-3. For maximum life and reliability, maintenance engineers and service technicians need only to follow a few simple rules.

1. For bearing-supported, rotor-mounted unions, connect both supply and drain hoses to the union before mounting the union on the spindle. Otherwise, bearings in the union may become brinnelled or galled when the hose connections are tightened.
2. Clean the mounting surfaces of the spindle thoroughly before mounting the union. The spindle pilot must be clean, with no chips, no burrs, and no dents. Otherwise, the union may exhibit runout and vibrate during rotation.
3. Make sure the drain hose runs downward continuously, with no "roller coaster" rises that could prevent proper drainage. If the spindle is horizontal, make sure that the union's drain hole is at 6 o'clock, pointing directly down. unions can do many things, but they can't break the law of gravity!

Following are examples of **correct** and incorrect installations, with an explanation of what is correct or **incorrect** about each example.

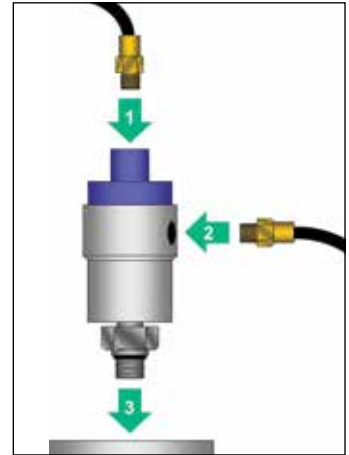

### Examples of **CORRECT** Installations



**WHAT'S RIGHT:** Elbow fitting is used to avoid a tight bend in supply hose. Drain hose slopes downward.



**WHAT'S RIGHT:** Flexible hose between rigid supply pipe and union. Drain hose runs straight down.



**WHAT'S RIGHT:** Flexible hose between rigid supply pipe and union. Drain hose runs straight down.



**WHAT'S RIGHT:** Elbow prevents excessive side load on bearings when supply hose is pressurized.

### Examples of **INCORRECT** Installations



**WHAT'S WRONG:** Drain line points up, which can flood the union's bearings.



**WHAT'S WRONG:** Union points up. Coolant contaminants will collect at the bottom and interfere with proper sealing.



**WHAT'S WRONG:** Union housing is rigidly attached to the spindle. Without 100% perfect alignment, this creates a side load leading to early bearing failure.



**WHAT'S WRONG:** Bend in supply hose is too tight. When pressurized, the supply hose may create a large side load on the union's bearings.

# INFORMATION FOR USERS OF MACHINE TOOLS

## COOLANT FILTRATION AND MAINTENANCE

Deublin unions are designed to handle the various coolant contaminants found in most manufacturing facilities. To ensure long union life and maximum productivity, however, coolant filtration should conform to ISO 4406:1999 Code 17/15/12, SAE 749 Class 5, or NAS 1638 Class 8, with a maximum particle size of 60 microns. For comparison, pumps (both fixed piston and variable volume) such as those used in coolant systems typically require ISO 4406 Code 16/14/11 or better – in other words, half as much contamination as Deublin.

Only pure water should be used to make up for coolant evaporation. Calcium and magnesium salts in most tap water shorten coolant life, by depleting the chemicals in the coolant, by breaking down the water-oil emulsion, and by encouraging bacterial growth. These salts also can cause residue to build up

inside the rotating union, leading to premature failure. One rule of thumb is that each additional “grain of hardness” (equivalent to 17 ppm or 17 mg/l of calcium carbonate) increases your annual coolant consumption by one percent. Proper coolant maintenance also prolongs tool life and improves the surface finish of your parts.



**Unacceptable**  
(ISO 21/19/17 at 100x)



**Acceptable**  
(ISO 16/14/11 at 100x)

ISO 4406:1999 Code 17/15/12	
Particle size (µm)	Particles per 100ml
4 – 6	≤ 130,000
6 – 14	≤ 32,000
14 – 60	≤ 4,000

NAS 1638 Class 8	
Particle size (µm)	Particles per 100ml
5 – 15	≤ 64,000
15 – 25	≤ 11,400
25 – 50	≤ 2,025
50 – 60	≤ 360

SAE 749-1963 Class 5	
Particle size (µm)	Particles per 100ml
5 – 10	≤ 87,000
10 – 25	≤ 21,400
25 – 50	≤ 3,130
50 – 60	≤ 430

## THREAD EQUIVALENCE

**Parallel or “straight” threads** are indicated in this catalog by the symbol “G”. British Standard Parallel threads are known by several other names in different parts of the world. Common symbols for this thread style include: BSP, BSPP, BSSPI, BSPF, BSPG, PF, Rp, and G. British Standard parallel threads also may be referred to as British Gas, British Pipe Parallel or Parallel Fastening Thread. The reference standards are described in ISO 228/1 and JIS B0202.

American Standard Unified threads, indicated by UN or UNF, also are parallel. However, they are not the same as and do not mate with G threads, since the thread angle and shape are different.

**The following examples are equivalent parallel threads:**

G 1/4"  
G 1/4" cyl  
PF 1/4"  
R 1/4" Tr  
1/4" BSP

**Tapered threads** are indicated in this catalog by the symbols “PT” and “NPT”. British Standard Taper threads are known by several other names, including: BSPT, BSPT<sub>r</sub>, PS, PT, R, and Rc. British Standard taper threads also may be referred to as Pipe Taper or Conical Thread. The reference standards are described in ISO 7/1 and JIS B0203.

American Standard NPT threads also are tapered, but not the same as PT threads. Both the thread angle and shape are different, so mating NPT with PT may not create a reliable seal.

**The following examples are equivalent tapered threads:**

R 1/4" keg  
G 1/4" co  
PT 1/4"  
R 1/4"  
Rc 1/4"  
1/4" BSPT

# DEUBLIN

## 1005 Series “Closed Seal” Rotating Unions for Continuous Coolant Service

- Single passage for coolant or MQL
- Closed seals for transfer line and similar applications
- Full-flow design has no obstructions to trap chips or debris
- Bearing-supported with threaded rotor for easy installation
- Labyrinth system and vents to protect ball bearings
- Balanced mechanical seals made from silicon carbide for long life even under difficult operating conditions
- Anodized housing and stainless steel rotor resist corrosion



### Operating Data

Media	Water-based Coolant MQL (oil mist) up to 10 bar (145 psi)	
Filtration	ISO 4406 Class 17/15/12, max. 60 micron	
Maximum Speed	15,000 min <sup>-1</sup>	15,000 rpm
Maximum Pressure	105 bar	1,520 psi
Maximum Flow	6.7 l/min	1.8 gpm
Maximum Temperature	71°C	160°F



**DO NOT RUN DRY**

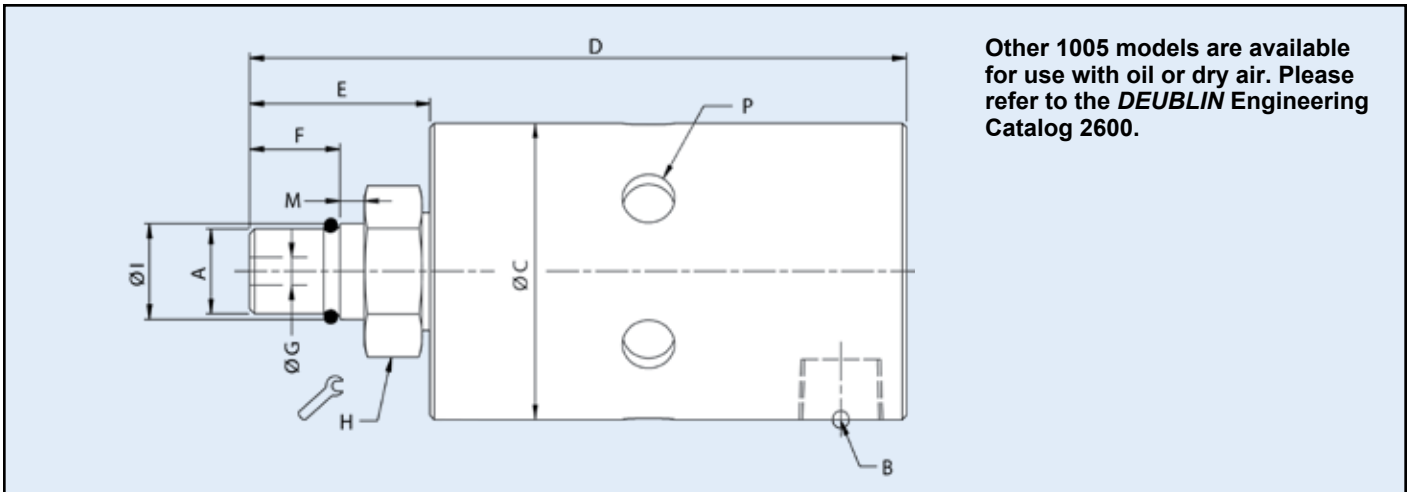
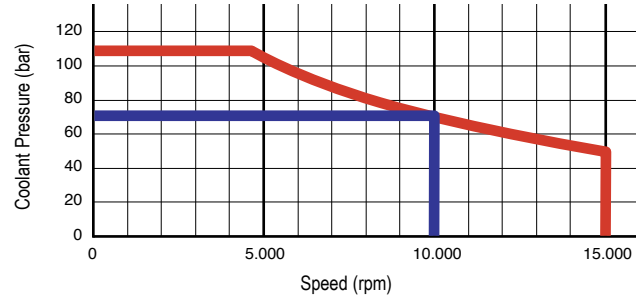

**Other 1005 models are available for use with oil or dry air. Please refer to the DEUBLIN Engineering Catalog 2600.**

Ordering Number	B Supply Connection	C Overall Diameter	D Overall Length	P Vent Size Ø (6 x 60°)	A Rotor Connection	E Rotor Length	F Thread Length	G Bore Diameter	H Across Flats	I Pilot Diameter	M Pilot Length
1005-402-401	1/8" NPT Radial	34	80	6.4	M10 x 1 RH	22	11	3.2	17	10.994 / 10.989	3
1005-402-448	1/8" NPT Radial	34	80	6.4	M10 x 1 LH	22	11	3.2	17	10.994 / 10.989	3
1005-704-434*	1/8" NPT Radial	34	80	3 x Rp 1/8"	M10 x 1 RH	22	11	3.4	17	10.994 / 10.989	5

\* Also allowed for hydraulics, compressed air and defined dry run cycles. For further information please contact DEUBLIN.

# DEUBLIN

## 1101 Series "Closed Seal" Rotating Unions for Continuous Coolant Service

- Single passage for coolant or MQL
- Closed seals for transfer line and similar applications
- Full-flow design has no obstructions to trap chips or debris
- Bearing-supported with threaded rotor for easy installation
- Deep groove radial ball bearings for smooth operation
- Labyrinth system and large vents to protect ball bearings
- Balanced mechanical seals made from silicon carbide for long life even under difficult operating conditions
- Anodized aluminum components resist corrosion



### Operating Data

Media	Water-based Coolant MQL (oil mist) up to 10 bar (145 psi)	
Filtration	ISO 4406 Class 17/15/12, max. 60 micron	
Maximum Speed	15,000 min <sup>-1</sup>	15,000 rpm
Maximum Pressure	105 bar	1,520 psi
Maximum Flow	20 l/min	5.3 gpm
Maximum Temperature	71°C	160°F



**DO NOT RUN DRY**

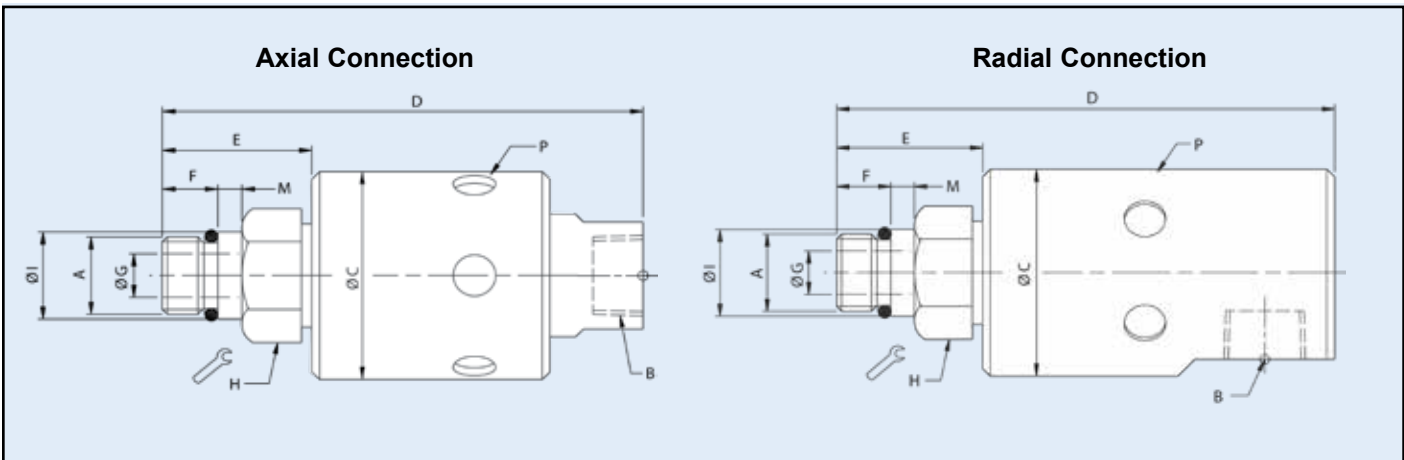
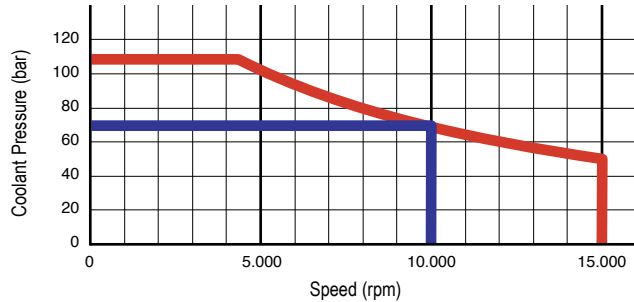

Ordering Number	B Supply Connection	C Overall Diameter	D Overall Length	P Vent Size Ø (6 x 60°)	A Rotor Connection	E Rotor Length	F Thread Length	G Bore Diameter	H Across Flats	I Pilot Diameter	M Pilot Length
1101-235-238	3/8" NPT Axial	43	100	9	5/8"-18 UNF LH	33	14	6	15/16"	0.6555" / 0.6553"	5
1101-235-239	3/8" NPT Axial	43	100	9	5/8"-18 UNF RH	33	14	6	15/16"	0.6555" / 0.6553"	5
1101-235-343	3/8" NPT Axial	43	96	9	M16 x 1.5 LH	30	11	6	24	17.993 / 17.988	5
1101-235-424	3/8" NPT Axial	43	93	9	M10 x 1 LH	27	11	3.2	24	10.994 / 10.989	3
1101-359-343	G 3/8" Axial	43	96	9	M16 x 1.5 LH	30	11	6	24	17.993 / 17.988	5
1101-195-343	G 3/8" Radial	43	102	9 PT	M16 x 1.5 LH	30	11	6	24	17.993 / 17.988	5
1101-632-343*	PT 3/8" Radial	43	103	3 x PT 1/8"	M16 x 1.5 LH	30	11	6	24	17.993 / 17.988	5
1101-265-343*	G 1/4" Radial	43	95	3 x PT 1/8"	M16 x 1.5 LH	30	11	6	24	17.993 / 17.988	5
1101-265-644*	G 1/4" Radial	43	91	3 x PT 1/8"	Flange TK-Ø 21	26	14.5	6	4 x M4	Ø 30.01 H6	8

\* Also allowed for hydraulics, compressed air and defined dry run cycles at reduced operating conditions. For further information please contact DEUBLIN or see page 22.

**This series includes additional models. For more information, contact DEUBLIN at +1-847-689-8600 or www.deublin.com**





# DEUBLIN

## 1116 Series "Closed Seal" Rotating Unions for Continuous Coolant Service

- Single passage for coolant or MQL
- Closed seals for transfer line and similar applications
- Full-flow design has no obstructions to trap chips or debris
- Bearing-supported with threaded rotor for easy installation
- Deep groove radial ball bearings for smooth operation
- Labyrinth system and large vents to protect ball bearings
- Balanced mechanical seals made from silicon carbide for long life even under difficult operating conditions
- Anodized aluminum housing resists corrosion

### Operating Data

Media	Water-based Coolant MQL (oil mist) up to 10 bar (145 psi)	
Filtration	ISO 4406 Class 17/15/12, max. 60 micron	
Maximum Speed	12,000 min <sup>-1</sup>	12,000 rpm
Maximum Pressure	70 bar	1,015 psi
Maximum Flow	82 l/min	21.6 gpm
Maximum Temperature	71°C	160°F



**DO NOT RUN DRY**

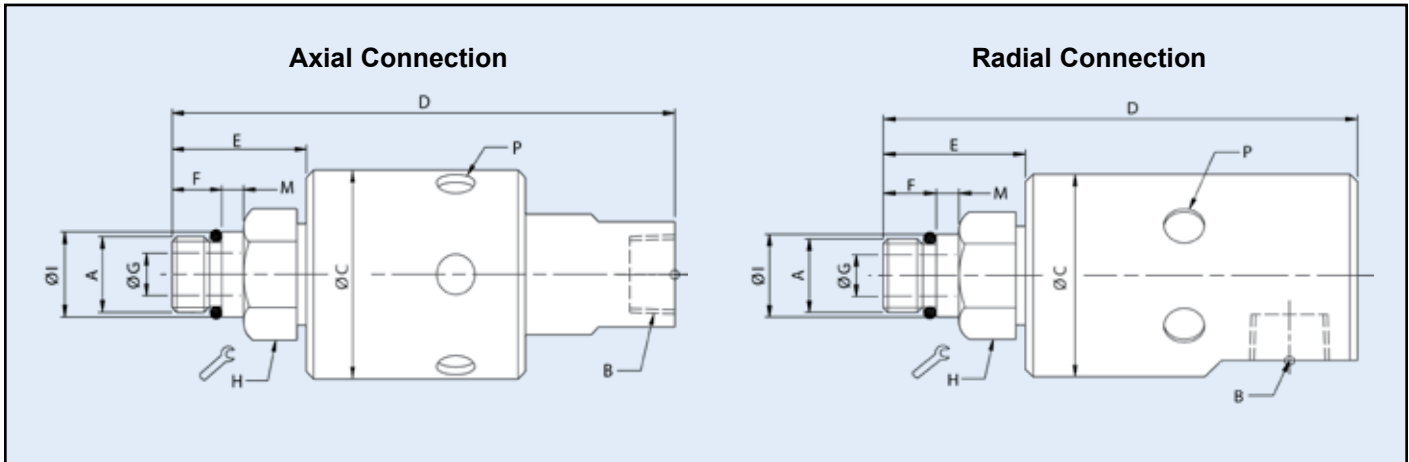
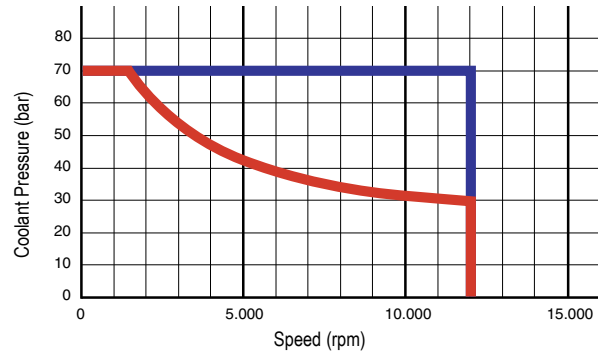

Ordering Number	B Supply Connection	C Overall Diameter	D Overall Length	P Vent Size Ø (6 x 60°)	A Rotor Connection	E Rotor Length	F Thread Length	G Bore Diameter	H Across Flats	I Pilot Diameter	M Pilot Length
1116-048-064	1/4" NPT Axial	44	115	9	5/8"-18 UNF RH	33	14	9	15/16"	0.6555" / 0.6553"	5
1116-048-463	1/4" NPT Axial	44	112	9	M16 x 1.5 LH	30	11	9	24	17.993 / 17.988	5
1116-485-463	G 1/4" Axial	44	112	9	M16 x 1.5 LH	30	11	9	24	17.993 / 17.988	5
1116-580-343	3/8" PT Axial	44	112	9	M12 x 1.25 LH	30	11	6	24	13.994 / 13.989	5
1116-600-059	3/8" NPT Axial	44	115	9	5/8"-18 UNF LH	33	14	9	15/16"	0.6555" / 0.6550"	5
1116-600-463	3/8" NPT Axial	44	112	9	M16 x 1.5 LH	30	11	9	24	17.993 / 17.988	5
1116-610-463	G 3/8" Axial	44	112	9	M16 x 1.5 LH	30	11	9	24	17.993 / 17.988	5
1116-090-059	3/8" NPT Radial	44	106	9	5/8"-18 UNF LH	33	14	9	15/16"	0.6555" / 0.6553"	5
1116-090-064	3/8" NPT Radial	44	106	9	5/8"-18 UNF RH	33	14	9	15/16"	0.6555" / 0.6553"	5
1116-090-463	3/8" NPT Radial	44	102	9	M16 x 1.5 LH	30	11	9	24	17.993 / 17.988	5
1116-516-463*	G 3/8" Radial	44	102	9	M16 x 1.5 LH	30	11	9	24	17.993 / 17.988	5
1116-555-463	G 3/8" Radial	44	103	9	M16 x 1.5 LH	30	11	9	24	17.993 / 17.988	5
1116-987-463*	G 3/8" Radial	44	102	9	M16 x 1.5 LH	30	11	9	24	17.993 / 17.988	5

\* Also allowed for hydraulics, compressed air and defined dry run cycles at reduced operating conditions. For further information please contact DEUBLIN or see page 22.

This series includes additional models. For more information, contact DEUBLIN at +1-847-689-8600 or [www.deublin.com](http://www.deublin.com)

# DEUBLIN

## 1108 Series "Closed Seal" Rotating Unions for Continuous Coolant Service

- Single passage for coolant or MQL
- Closed seals for transfer line and similar applications
- Full-flow design has no obstructions to trap chips or debris
- Bearing-supported with threaded rotor for easy installation
- Dual ABEC 7 (ISO class P4) angular contact ball bearings
- Labyrinth system and large vents to protect ball bearings
- Balanced mechanical seals made from silicon carbide for long life even under difficult operating conditions
- Anodized aluminum housing resists corrosion



### Operating Data

Media	Water-based Coolant MQL (oil mist) up to 10 bar (145 psi)		
Filtration	ISO 4406 Class 17/15/12, max. 60 micron		
Maximum Speed	20,000 min <sup>-1</sup>	20,000 rpm	
Maximum Pressure	See chart		
Maximum Flow	82 l/min	21.6 gpm	Standard
	24.3 l/min	6.4 gpm	High Pressure
	2.7 l/min	0.7 gpm	Very High Pressure (VHP)
Maximum Temperature	71°C	160°F	



DO NOT RUN DRY

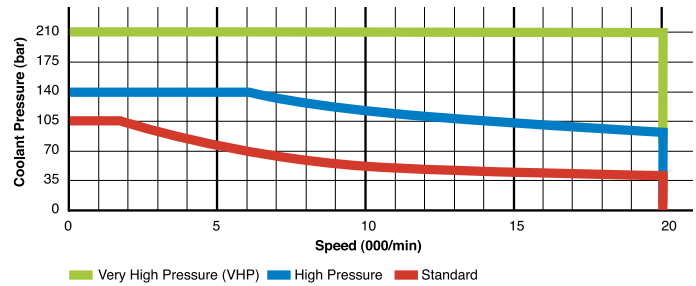

### Axial Connection

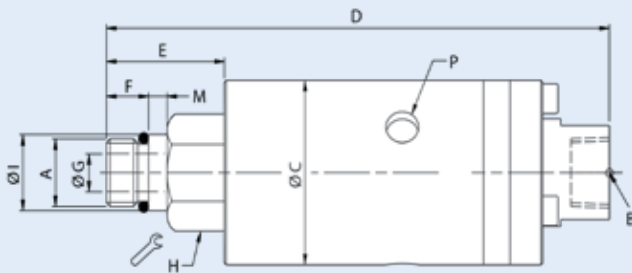

### Radial Connection

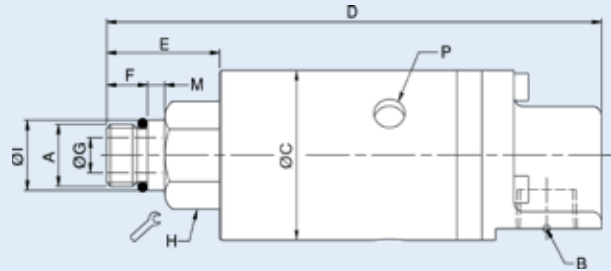

Ordering Number	B Supply Connection	C Overall Diameter	D Overall Length	P Vent Size (3 x 120°)	A Rotor Connection	E Rotor Length	F Thread Length	G Bore Diameter	H Across Flats	I Pilot Diameter	M Pilot Length
1108-002-102	3/8" NPT Axial	44	132	9	5/8"-18 UNF LH	34	14	9	15/16"	0.6555" / 0.6553"	5
1108-002-153	3/8" NPT Axial	44	132	9	M16 x 1.5 LH	31	11	9	24	17.993 / 17.988	5
1108-001-102	3/8" NPT Radial	44	138	9	5/8"-18 UNF LH	34	14	9	15/16"	0.6555" / 0.6553"	5
1108-011-153	G 3/8" Radial	44	135	9	M16 x 1.5 LH	30	11	9	24	17.993 / 17.988	5
1108-034-212	G 1/4" Axial	53	129	G 1/4"	M16 x 1.5 LH	30	11	9	24	17.993 / 17.988	5
1108-058-212	G 1/4" Radial	53	135	G 1/4"	M16 x 1.5 LH	30	11	9	24	17.993 / 17.988	5
1108-093-559	1/4" NPT Axial	44	132	9	M16 x 1.5 LH	30	11	9	24	17.993 / 17.988	5

This series includes additional models. For more information, contact DEUBLIN at +1-847-689-8600 or [www.deublin.com](http://www.deublin.com)



# DEUBLIN

## 1108 Series "Closed Seal" Bore-Mounted Rotating Unions for Coolant Service

- Single passage for coolant or MQL
- Closed seals
- Accepts up to 19 mm of draw bar movement
- Full-flow design has no obstructions to trap swarf or debris
- Labyrinth system and large vents to protect ball bearing
- Dry run cycles possible depending on model
- Balanced mechanical seals made from silicon carbide for long life even under difficult operating conditions
- Stainless steel housing and rotor
- Anodised aluminum end cap

### Operating Data

Media	Water-based Coolant MQL (oil mist) up to 10 bar (145 psi)	
Filtration	ISO 4406 Class 17/15/12, max. 60 micron	
Max. Speed	see graph/table	
Max. Pressure	150 bar	2,176 psi
Max. Flow	24,3 l/min	6.4 gpm
Max. Temperature	71 °C	160 °F



DEFINED DRY RUN

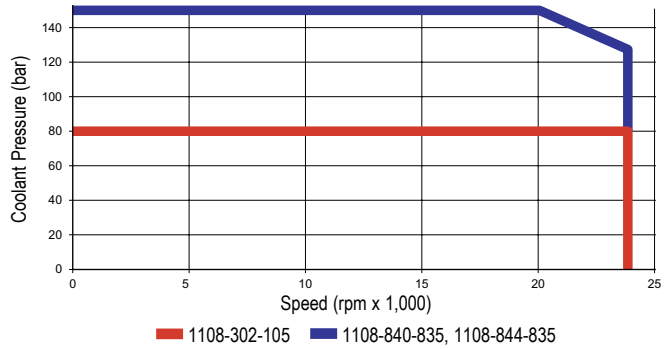

1108-302-105

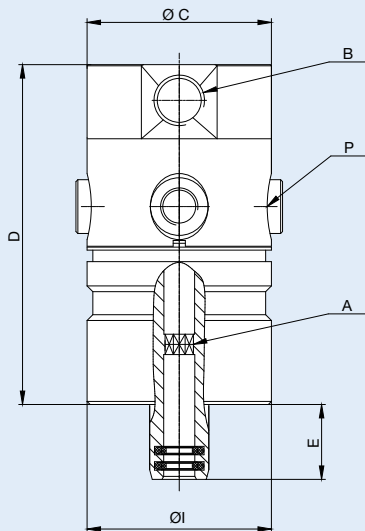

1108-840-835 / 1108-844-835

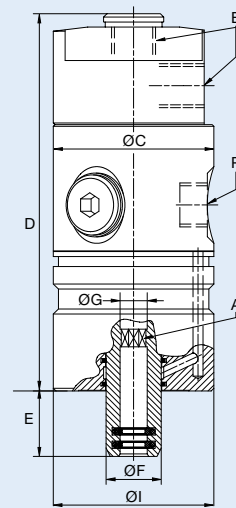

Ordering Number	B Supply Connection	C Overall Diameter	D Housing Length	P Vent Size Ø (3 x 120°)	A Rotor Connection	E Rotor Length	F Rotor Overall Diameter	G Bore Diameter	I Pilot Diameter	Maximum Speed (rpm)	Max. Pressure (bar)
1108-302-105	G 1/4" Radial	48	88.5	G 1/8 (4x90°)	Octagon 7.4 D10	19.5	15.4	8.1 F9	48 h7	24,000	80
1108-840-835	G 1/4" Axial & Radial	48	112	G 1/4 (3x120°)	Octagon 7.4 D10	19.5	15.9	8.1 F9	48 g6	24,000	150
1108-844-835	G 1/4" Axial & Radial	48	112	4 mm (12x30°)	Octagon 7.4 D10	19.5	15.9	8.1 F9	44 g6	24,000	150

This series includes additional models. For more information, contact DEUBLIN at +1-847-689-8600 or [www.deublin.com](http://www.deublin.com)

# DEUBLIN

## 1109 Series Pop-Off® Rotor-Mounted Rotating Unions for Coolant Service with Dry Running

- Single passage for coolant or MQL
- Pop-Off® technology allows unlimited dry running without media pressure
- Full-flow design has no obstructions to trap chips or debris
- Bearing-supported with threaded rotor for easy installation
- Dual ABEC 7 (ISO class P4) angular contact ball bearings
- Labyrinth system and large vents to protect ball bearings
- Balanced mechanical seals made from silicon carbide for long life even under difficult operating conditions
- Anodized aluminum housing resists corrosion



### Operating Data

Media	Water-based Coolant MQL (oil mist) up to 10 bar (145 psi)		
Filtration	ISO 4406 Class 17/15/12, max. 60 micron		
Maximum Speed	20,000 min <sup>-1</sup>	20,000 rpm	
Maximum Pressure	See chart		
Maximum Flow	82 l/min 24.3 l/min	21.6 gpm 6.4 gpm	Standard High Pressure
Maximum Temperature	71°C	160°F	



**NO AIR PRESSURE  
WITH ROTATION**

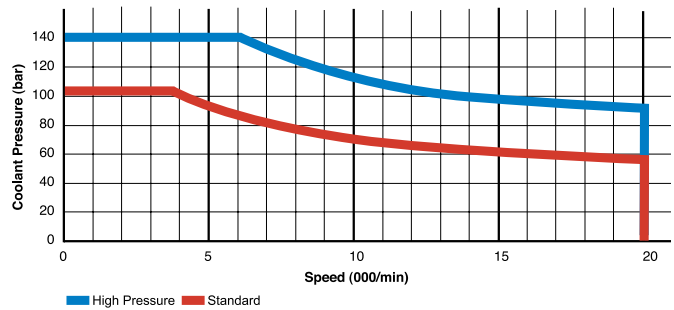

### Axial Connection

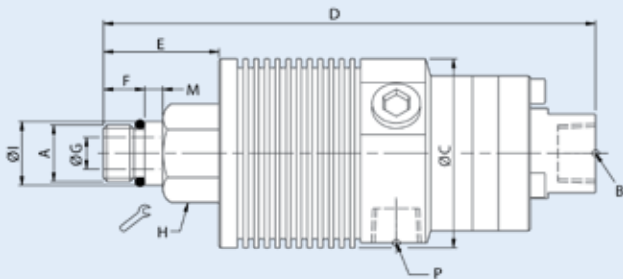

### Radial Connection

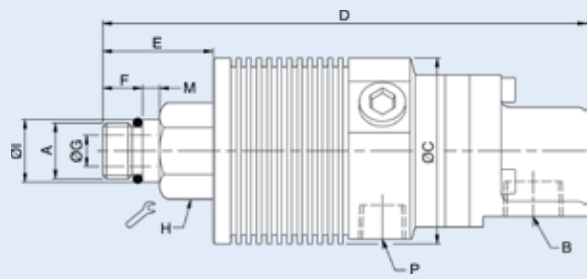

	Ordering Number	B Supply Connection	C Overall Diameter	D Overall Length	P Vent Size (3 X 120°)	A Rotor Connection	E Rotor Length	F Thread Length	G Bore Diameter	H Across Flats	I Pilot Diameter	M Pilot Length
Standard	1109-011-165	3/8" NPT Axial	53	132	1/4" NPT	5/8"-18 UNF LH	34	14	9	15/16"	0.6555" / 0.6553"	5
	1109-021-188	G 3/8" Axial	53	129	G 1/4"	M16 x 1.5 LH	31	11	9	24	17.993 / 17.988	5
	1109-041-188	3/8" PT Axial	53	129	1/4" PT	M16 x 1.5 LH	31	11	9	24	17.993 / 17.988	5
	1109-010-165	3/8" NPT Radial	53	138	1/4" NPT	5/8"-18 UNF LH	34	14	9	15/16"	0.6555" / 0.6553"	5
	1109-020-188	G 3/8" Radial	53	135	G 1/4"	M16 x 1.5 LH	31	11	9	24	17.993 / 17.988	5
	1109-040-188	3/8" PT Radial	53	135	1/4" PT	M16 x 1.5 LH	31	11	9	24	17.993 / 17.988	5
High Pressure	1109-014-196	1/4" NPT Axial	53	132	1/4" NPT	5/8"-18 UNF LH	34	14	9	15/16"	0.6555" / 0.6553"	5
	1109-024-212	G 1/4" Axial	53	129	G 1/4"	M16 x 1.5 LH	31	11	9	24	17.993 / 17.988	5
	1109-044-212	1/4" PT Axial	53	129	1/4" PT	M16 x 1.5 LH	31	11	9	24	17.993 / 17.988	5
	1109-013-196	1/4" NPT Radial	53	138	1/4" NPT	5/8"-18 UNF LH	34	14	9	15/16"	0.6555" / 0.6553"	5
	1109-023-212	G 1/4" Radial	53	135	G 1/4"	M16 x 1.5 LH	31	11	9	24	17.993 / 17.988	5
	1109-043-212	1/4" PT Radial	53	135	1/4" PT	M16 x 1.5 LH	31	11	9	24	17.993 / 17.988	5

**This series includes additional models. For more information,  
contact DEUBLIN at +1-847-689-8600 or [www.deublin.com](http://www.deublin.com)**





# DEUBLIN

## 1109 Series Pop-Off® Bore-Mounted Rotating Unions for Coolant Service with Dry Running

- Single passage for coolant or MQL
- Pop-Off® technology allows unlimited dry running without media pressure
- Accepts up to 19 mm of axial drawbar movement
- Full-flow design has no obstructions to trap chips or debris
- Bore-mounted design for easy installation
- Matched, ISO class P4 hybrid ball bearings for smooth operation at high speeds
- Labyrinth system and large vents to protect ball bearings
- Balanced mechanical seals made from silicon carbide for long life even under difficult operating conditions
- Anodized aluminum and stainless steel parts resist corrosion

### Operating Data

Media	Water-based Coolant		
	MQL (oil mist) up to 10 bar (145 psi)		
Filtration	ISO 4406 Class 17/15/12, max. 60 micron		
Maximum Speed	See chart		
Maximum Pressure	140 bar	2,030 psi	
Maximum Flow	24.3 l/min	6.4 gpm	
1109-710-717	82 l/min	21.6 gpm	
Maximum Temperature	71°C	160°F	



**NO AIR PRESSURE  
WITH ROTATION**

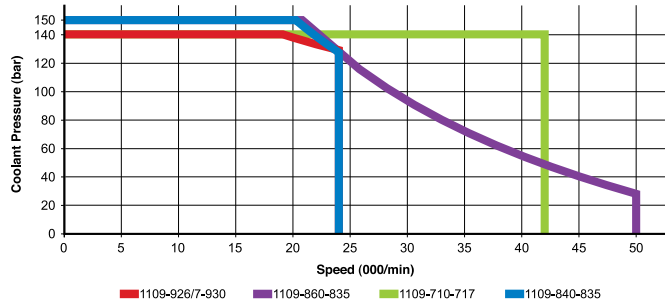

Axial Connection		Radial Connection		Example 1109-840-835							
Ordering Number	B Supply Connection	C Overall Diameter	D Housing Length	P Vent Size Ø (3 x 120°)	A Rotor Connection	E Rotor Length	F Rotor Overall Diameter	G Bore Diameter	I Pilot Diameter	Maximum Speed (rpm)	Max. Pressure (bar)
1111-002-105*	G 1/4" Radial	48	88.5	4 x G 1/8"	Octagon 7.4 D10	19.5	15.4	8.1 F9	48 h7	24,000	140
1109-710-730	G 3/8" Radial	59	109	G 1/4"	Octagon 9.25 D10	19.5	20	10 F9	48 g6	24,000	140
1109-710-717	G 3/8" Axial	59	109	G 1/4"	Hexagon 12 D10	25.0	18.0	11 H7	48 g6	24,000	140
1109-840-835	G 1/4" Axial & Radial	48	112	G 1/4"	Octagon 7.4 D10	19.5	15.9	8.1 F9	48 g6	24,000	150
1109-842-730	G 3/8" Axial & Radial	48	116	G 1/4"	Octagon 9.25 D10	19.5	16	10 F9	48 g6	24,000	150
1109-926-930	G 1/4" Radial	48	93	G 1/4"	Octagon 7.4 D10	19.5	15.4	8.1 F9	48 h7	42,000	140
1109-927-930	G 1/4" Axial	48	93	G 1/4"	Octagon 7.4 D10	19.5	15.4	8.1 F9	48 h7	42,000	140
1109-860-835	G 1/4" Axial & Radial	48	109	G 1/4"	Octagon 7.4 D10	19.5	16.5	8.1 F9	48 g6	50,000	150

\* Ultra-short (0.1 mm) pop-off stroke restricts drainage of residual coolant during tool change.

This series includes additional models. For more information, contact DEUBLIN at +1-847-689-8600 or [www.deublin.com](http://www.deublin.com)

# DEUBLIN

## 1114 Series AutoSense® Rotor-Mounted Rotating Unions for Coolant and Air Service with Dry Running

- Single passage for both coolant and dry air
- Patented AutoSense® technology automatically changes between closed seals and controlled leakage operation in response to the kind of media
- Dual ABEC 7 (ISO class P4) angular contact ball bearings
- Threaded rotor for easy installation
- Full-flow design has no obstructions to trap chips or debris
- Labyrinth system and large vents to protect bearings
- Balanced mechanical seals made from silicon carbide for long life even under difficult operating conditions
- Anodized aluminum housing resists corrosion



### Operating Data

Media	Water-based Coolant MQL (oil mist) up to 10 bar (145 psi) Air up to 10 bar (145 psi)		
Filtration	ISO 4406 Class 17/15/12, max. 60 micron		
Maximum Speed	22,000 min <sup>-1</sup>	22,000 rpm	
Maximum Pressure	See chart		
Maximum Flow	82 l/min 24.3 l/min	21.6 gpm 6.4 gpm	Standard High Pressure
Maximum Temperature	71°C	160°F	

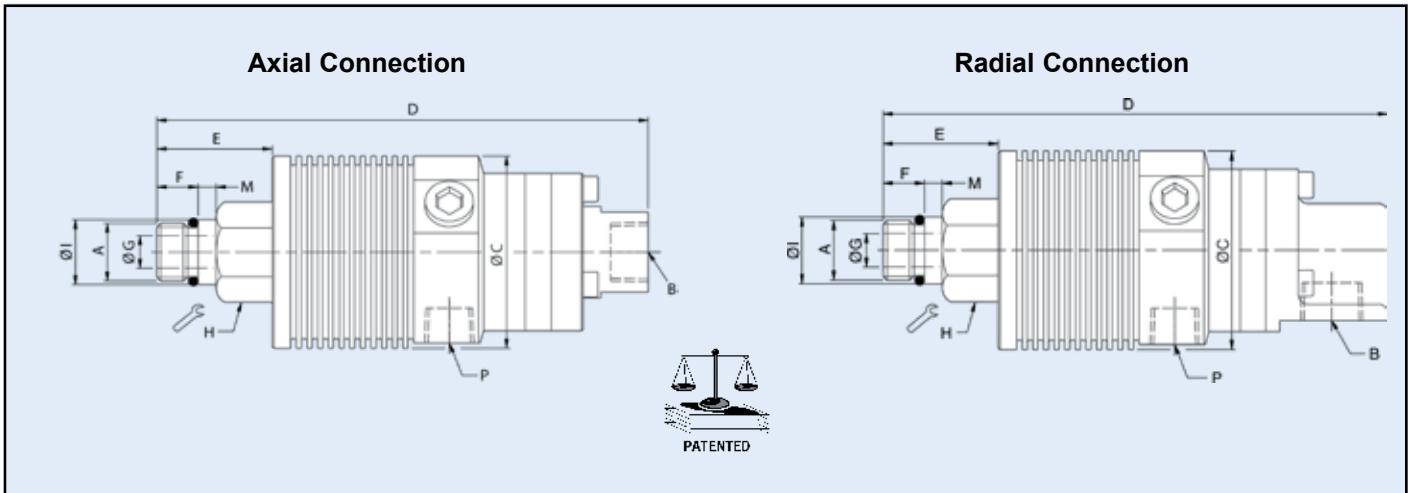
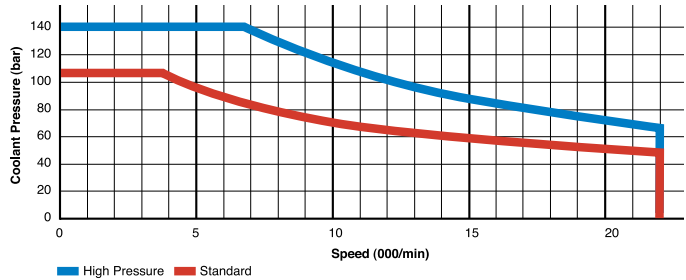

	Ordering Number	B Supply Connection	C Overall Diameter	D Overall Length	P Vent Size (3 X 120°)	A Rotor Connection	E Rotor Length	F Thread Length	G Bore Diameter	H Across Flats	I Pilot Diameter	M Pilot Length
Standard	1114-011-165	3/8" NPT Axial	53	134	1/4" NPT	5/8"-18 UNF LH	34	14	9	15/16"	0.6555" / 0.6553"	5
	1114-021-188	G 3/8" Axial	53	131	G 1/4"	M16 x 1.5 LH	31	11	9	24	17.993 / 17.988	5
	1114-041-188	3/8" PT Axial	53	131	1/4" PT	M16 x 1.5 LH	31	11	9	24	17.993 / 17.988	5
	1114-010-165	3/8" NPT Radial	53	140	1/4" NPT	5/8"-18 UNF LH	34	14	9	15/16"	0.6555" / 0.6553"	5
	1114-020-188	G 3/8" Radial	53	137	G 1/4"	M16 x 1.5 LH	31	11	9	24	17.993 / 17.988	5
	1114-040-188	3/8" PT Radial	53	137	1/4" PT	M16 x 1.5 LH	31	11	9	24	17.993 / 17.988	5
High Pressure	1114-024-212	G 1/4" Axial	53	131	G 1/4"	M16 x 1.5 LH	31	11	9	24	17.993 / 17.988	5
	1114-023-212	G 1/4" Radial	53	137	G 1/4"	M16 x 1.5 LH	31	11	9	24	17.993 / 17.988	5
	1114-044-212	1/4" PT Axial	53	131	1/4" PT	M16 x 1.5 LH	31	11	9	24	17.993 / 17.988	5
	1114-043-212	1/4" PT Radial	53	137	1/4" PT	M16 x 1.5 LH	31	11	9	24	17.993 / 17.988	5

This series includes additional models. For more information, contact DEUBLIN at +1-847-689-8600 or [www.deublin.com](http://www.deublin.com)

# DEUBLIN

## 1114 Series AutoSense® Bore-Mounted Rotating Unions for Coolant and Air Service with Dry Running



- Single passage for both coolant and dry air
- Patented AutoSense® technology automatically changes between closed seals and controlled leakage operation in response to the kind of media
- Bore-mounted design for easy installation
- Accepts up to 19 mm of axial drawbar movement
- Matched, ISO class P4 hybrid ball bearings for smooth operation at high speeds
- Labyrinth system and large vents to protect ball bearings
- Full-flow design has no obstructions to trap swarf or debris
- Balanced mechanical seals made from silicon carbide for long life even under difficult operating conditions
- Anodised aluminium and stainless steel parts resist corrosion

### Operating Data

Media	Water-based Coolant MQL (oil mist) up to 10 bar (145 psi) Air up to 10 bar (145 psi)		
Filtration	ISO 4406 Class 17/15/12, max. 60 micron		
Max. Speed	see chart/table		
Max. Pressure	see chart/table		
Max. Flow			
1114-710-xxx	82 l/min	21.6 gpm	
1114-842-730	82 l/min	21.6 gpm	
1114-331-105	24,3 l/min	6.4 gpm	
1114-92x-930	24,3 l/min	6.4 gpm	
Max. Temperature	71 °C	160 °F	

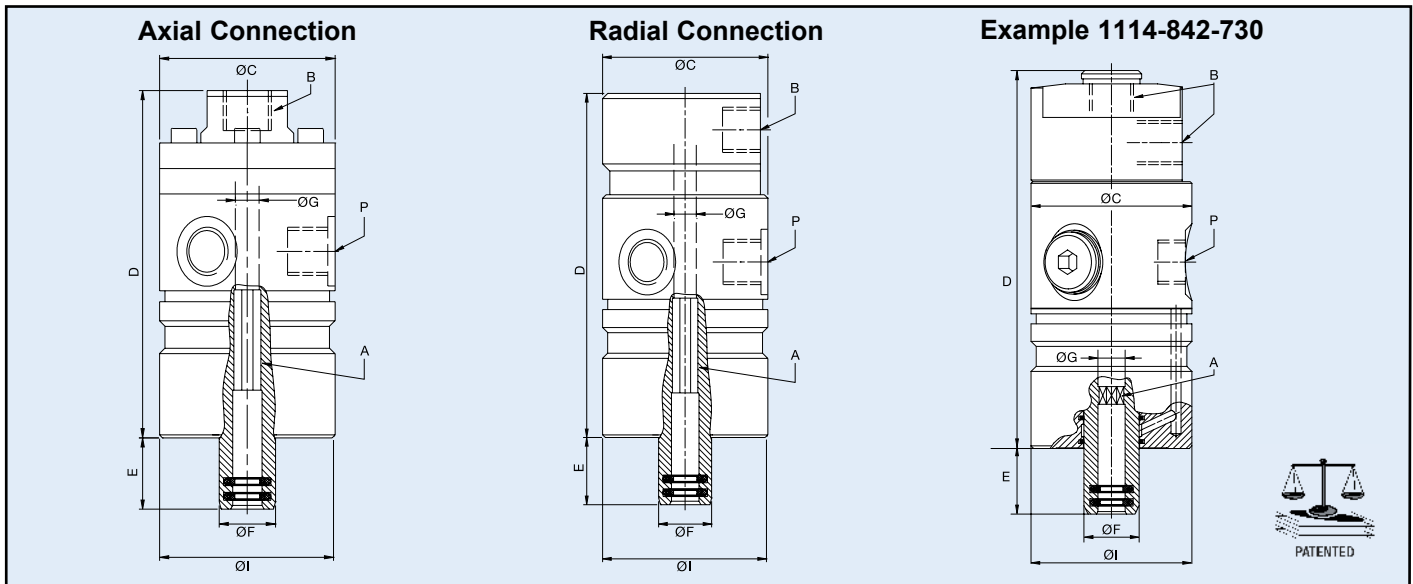
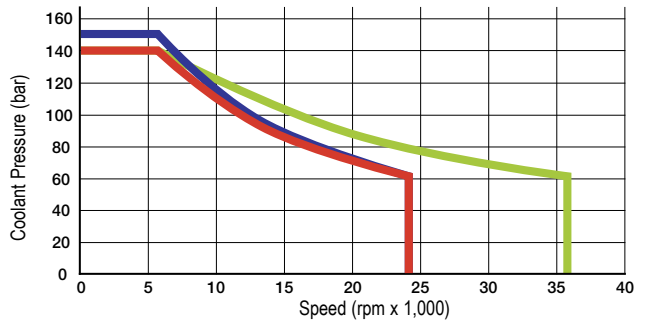

Ordering Number	B Supply Connection	C Overall Diameter	D Housing Length	P Drain Size Ø (3 x 120°)	A Rotor Connection	E Rotor Length	F Rotor Overall Diameter	G Bore Diameter	I Pilot Diameter	Max. Speed (rpm)	Max. Pressure (bar)
1114-331-105	G 1/4" Radial	48	88.5	4x G 1/8"	Octagon 7.4 D10	19.5	15.4	8.1 F9	48 h7	24,000	140
1114-710-730	G 3/8" Axial	59	111	G 1/4"	Octagon 9.25 D10	19.5	20	10 F9	48 g6	24,000	140
1114-710-717	G 3/8" Axial	59	111	G 1/4"	Hexagon 12 D10	25	18	11 H7	48 g6	24,000	140
1114-842-730	G 1/4" Axial & Radial	48	120	G 1/4"	Octagon 9.25 D10	19.5	16	10 F9	48 g6	24,000	150
1114-927-930	G 1/4" Axial	48	95	G 1/4"	Octagon 7.4 D10	19.5	15.4	8.1 F9	48 h7	36,000	140
1114-926-930	G 1/4" Radial	48	95	G 1/4"	Octagon 7.4 D10	19.5	15.4	8.1 F9	48 h7	36,000	140

This series includes additional models. For more information, contact DEUBLIN at +1-847-689-8600 or [www.deublin.com](http://www.deublin.com)

# DEUBLIN

## 902 Series Pop-Off® Rotating Unions for Coolant Service with Dry Running



- Single passage for coolant or MQL
- Pop-Off® technology allows unlimited dry running without media pressure
- Full-flow design has no obstructions to trap chips or debris
- Bearing-supported with threaded rotor for easy installation
- Deep groove radial ball bearings for smooth operation
- Labyrinth system and large vents to protect ball bearings
- Balanced mechanical seals made from silicon carbide for long life even under difficult operating conditions
- Anodized aluminum housing resists corrosion

### Operating Data

Media	Water-based Coolant MQL (oil mist) up to 10 bar (145 psi)	
Filtration	ISO 4406 Class 17/15/12, max. 60 micron	
Maximum Speed	12,000 min <sup>-1</sup>	12,000 rpm
Maximum Pressure	70 bar	1,015 psi
Maximum Flow	82 l/min	21.6 gpm
Maximum Flow <sup>1</sup>	24.3 l/min	6.4 gpm
Maximum Temperature	71°C	160°F



**NO AIR PRESSURE  
WITH ROTATION**

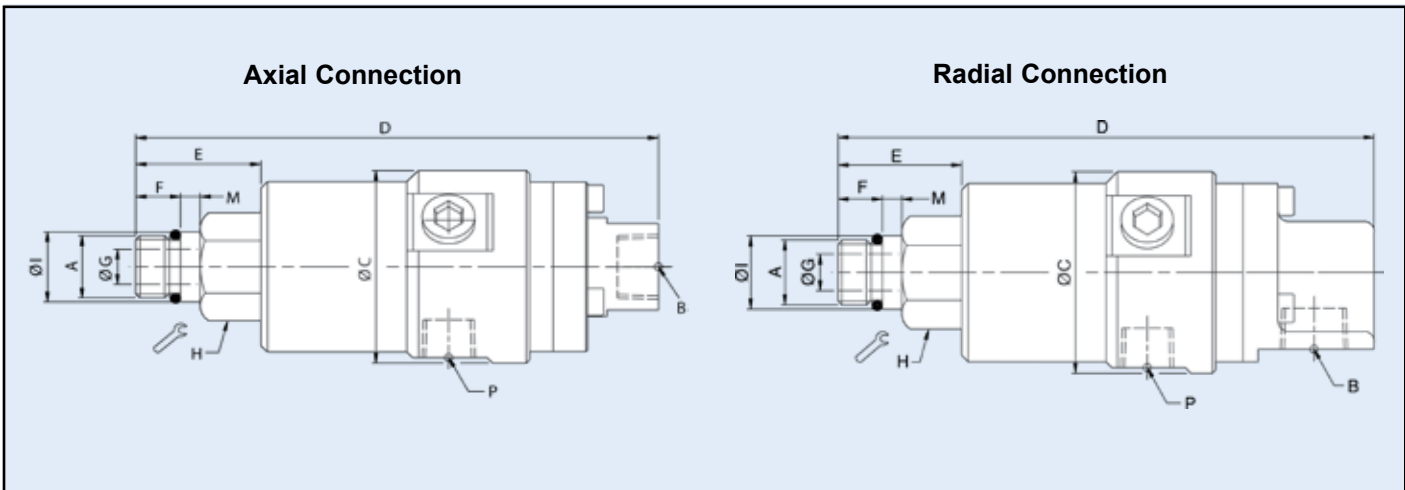
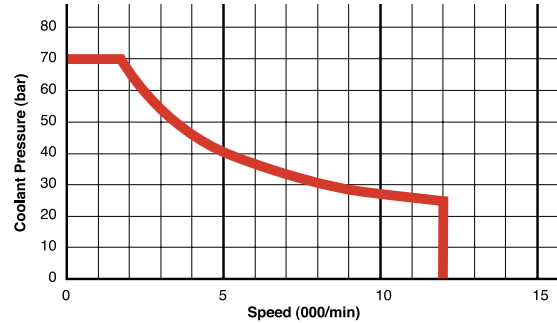

	Ordering Number	B Supply Connection	C Overall Diameter	D Overall Length	P Vent Size (3 X 120°)	A Rotor Connection	E Rotor Length	F Thread Length	G Bore Diameter	H Across Flats	I Pilot Diameter	M Pilot Length
Axial Connection	902-111-165	3/8" NPT	49.5	132	1/4" NPT	5/8"-18 UNF LH	36	15	9	15/16"	0.6555" / 0.6553"	5
	902-121-188	G 3/8"	49.5	129	G 1/4"	M16 x 1.5 LH	33	11	9	24	17.993 / 17.988	5
	902-138-188 <sup>1</sup>	G 3/8"	49.5	129	G 1/4"	M16 x 1.5 LH	33	11	9	24	17.993 / 17.988	5
	902-141-188	3/8" PT	49.5	129	1/4" PT	M16 x 1.5 LH	33	11	9	24	17.993 / 17.988	5
Radial Connection	902-110-165	3/8" NPT	49.5	138	1/4" NPT	5/8"-18 UNF LH	36	15	9	15/16"	0.6555" / 0.6553"	5
	902-120-188	G 3/8"	49.5	135	G 1/4"	M16 x 1.5 LH	33	11	9	24	17.993 / 17.988	5
	902-137-188 <sup>1</sup>	G 3/8"	49.5	135	G 1/4"	M16 x 1.5 LH	33	11	9	24	17.993 / 17.988	5
	902-140-188	3/8" PT	49.5	135	1/4" PT	M16 x 1.5 LH	33	11	9	24	17.993 / 17.988	5
	902-225-101*	G 3/8"	49.5	135	G 1/4"	Two-Flat 12	26	NA	9	NA	11.984 / 11.966	16
	902-120-104 <sup>1</sup>	G 3/8"	49.5	137	G 1/4"	Female 12	34	NA	9	24	12.027 / 12.000	32
	902-253-220	G 3/8"	46.8	139	G 1/4"	Hexagon 11	34	NA	9	NA	12.984 / 12.957	21

\* This union is a bore-mounted design.

**This series includes additional models. For more information, contact at +1-847-689-8600 or [www.deublin.com](http://www.deublin.com)**





# DEUBLIN

## 7000 and 1115 Series "Controlled Leakage" Rotating Unions for Dry Air or Vacuum at High Speed

- Single passage for dry or lubricated air
- Bearings are lubricated for life
- Full-flow design has no obstructions to trap chips or debris
- Threaded rotor for easy installation
- Balanced mechanical seals made from silicon carbide for long life even under difficult operating conditions
- Anodized aluminum and stainless steel parts resist corrosion

### Operating Data

Media	Air (dry or lubricated) Vacuum (7000-027-468 only)	
Maximum Speed	1115-114-xxx	15,000 min <sup>-1</sup> 15,000 rpm
	1115-680-xxx	15,000 min <sup>-1</sup> 15,000 rpm
	7000-xxx-xxx	18,000 min <sup>-1</sup> 18,000 rpm
Maximum Pressure	10 bar	145 psi
Maximum Flow	1115-114-xxx	2,460 l/min    87 SCFM
	1115-680-xxx	2,460 l/min    87 SCFM
	7000-xxx-xxx	1,060 l/min    37 SCFM
Maximum Temperature	121°C	250°F



DRY AIR SERVICE

### Axial Connection (7000 Series)

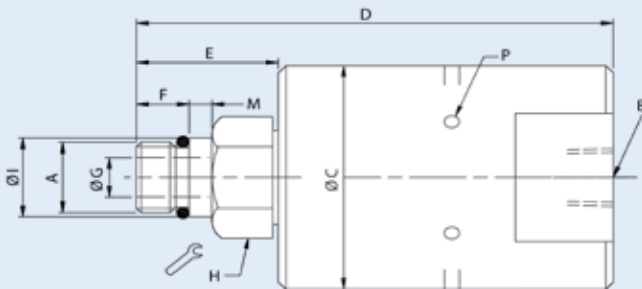

### Radial Connection (1115 Series)

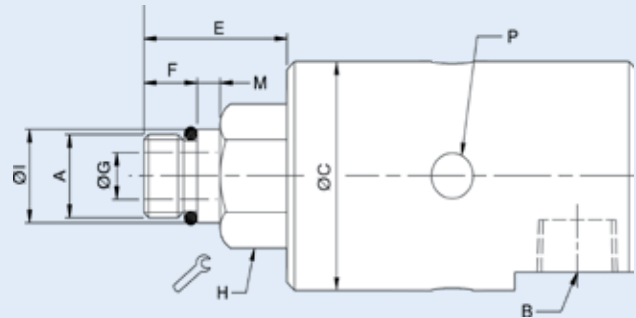

	Ordering Number	B Supply Connection	C Overall Diameter	D Overall Length	P Vent Size (6 X 90°)	A Rotor Connection	E Rotor Length	F Thread Length	G Bore Diameter	H Across Flats	I Pilot Diameter	M Pilot Length
Axial Connection	7000-003-117	1/4" PT	51	97	3	M16 x 1.5 RH	26	11	6	24	17.993 / 17.988	5
	7000-003-118	1/4" PT	51	97	3	M16 x 1.5 LH	26	11	6	24	17.993 / 17.988	5
	7000-003-224	1/4" PT	51	100	3	5/8"-18 UNF RH	30	14	6	15/16"	0.6555" / 0.6553"	5
	7000-003-225	1/4" PT	51	100	3	5/8"-18 UNF LH	30	14	6	15/16"	0.6555" / 0.6553"	5
	7000-027-468*	3/8" NPT	51	100	3	5/8"-18 UNF LH	30	14	9	15/16"	0.6555" / 0.6553"	5
	Ordering Number	B Supply Connection	C Overall Diameter	D Overall Length	P Vent Size (4 X 90°)	A Rotor Connection	E Rotor Length	F Thread Length	G Bore Diameter	H Across Flats	I Pilot Diameter	M Pilot Length
Radial Connection	1115-114-402	G 3/8"	44	106	9	5/8"-18 UNF LH	33	14	9	15/16"	0.6555" / 0.6553"	5
	1115-114-556	G 3/8"	44	106	9	M16 x 1.5 LH	30	11	9	24	17.993 / 17.988	5
	1115-680-402	3/8" NPT	44	106	9	5/8"-18 UNF LH	33	14	9	15/16"	0.6555" / 0.6553"	5
	1115-680-403	3/8" NPT	44	106	9	5/8"-18 UNF RH	33	14	9	15/16"	0.6555" / 0.6553"	5

\* Model 7000-027-468 is for vacuum and air service.

Note: Special two-passagge unions for air and oil (used for MQL mixed in the spindle) may be found on page 33.

This series includes additional models. For more information, contact DEUBLIN at +1-847-689-8600 or [www.deublin.com](http://www.deublin.com)

# DEUBLIN

## 1005/1101/1116 Series Rotating Unions for Multi-Media-Application

- Single passage for clamping, unclamping, lubricating, cooling and sensing applications
- Special design closed seals for multi-media-applications and dry run cycles
- All-purpose design; one model for various applications
- Full-flow design has no obstructions to trap swarf or debris
- Rotor-mounted design for easy installation
- Deep groove radial ball bearings for smooth operation
- Labyrinth system and large vents to protect ball bearings
- Anodised aluminium housing resists corrosion



### Operating Data

Filtration	ISO 4406 Class 17/15/12, max. 60 micron	
Max. Speed*	10.000 min <sup>-1</sup>	10,000 rpm
Max. Pressure		
Hydraulic	70 bar	1,015 psi
Coolant	70 bar	1,015 psi
Lubricant	70 bar	1,015 psi
MQL	10 bar	145 psi
Compressed Air	6 bar	87 psi
Dry run	defined dry run cycles	
Max. Flow	Coolant see table	
Max. Temperature	71 °C	160 °F

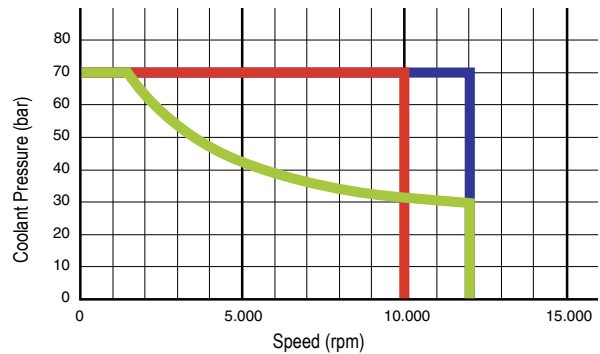
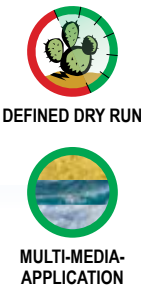

\* 1116 series: max. 3,500 rpm for compressed air and hydraulic service

### 1101-265-644

### Radial Connection

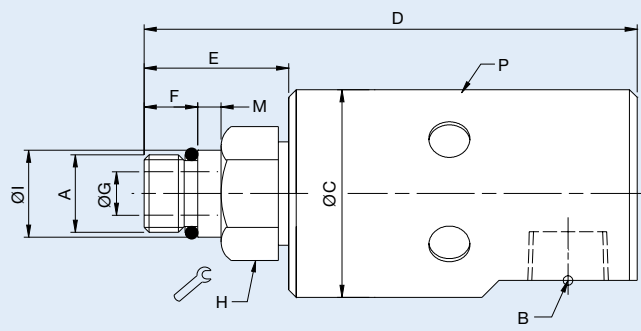
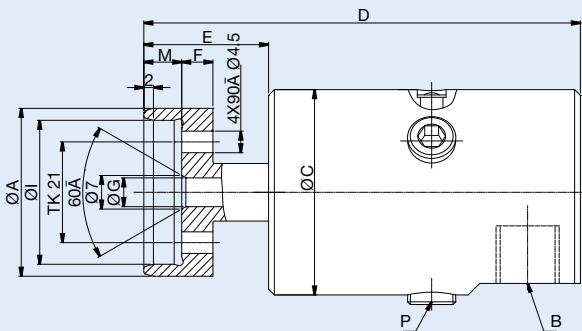

Ordering Number	B Supply Connection B	Flow Coolant l/min	D Overall Length	C Overall Diameter	P Drain Size Ø (6 x 60°)	A Rotor Connection	E Rotor Length	F Thread Length	G Bore Diameter	H Across Flats	I Pilot Diameter	M Pilot Length
1005-704-434	1/8" NPT Radial	11	80	34	3xRp 1/8"	M10x1 RH	22	11	3.4	17	10.994/10.989	5
1101-265-239	G 1/4" Radial	20	98	43	3xRp 1/8"	5/8-18 UNF RH	33	14.3	6.4	24	0.6555"/0.6553"	5
1101-265-343	G 1/4" Radial	20	95	43	3xRp 1/8"	M16x1.5 LH	30	11.1	6	24	17.993/17.988	5
1101-265-644	G 1/4" Radial	20	91	43	3xRp 1/8"	Flange 35 h8	26	6.5	6	4xM4	30.01 H6	8
1116-987-463	G 3/8" Radial	82	102	44	6x 8.5	M16x1.5 LH	30	11	8.5	24	17.993/17.998	5
1101-632-343	PT 3/8" Radial		103	43	3 x PT 1/8"	M16 x 1.5 LH	30	11	6	24	17.993/17.998	5
1116-516-463*	G 3/8" Radial	82	102.4	44	6x 8.5 closed	M16x1.5 LH	30	11	8.5	24	17.993/17.998	5
1116-063-463*	G 3/8" Axial	82	112	44	6x 8.5	M16x1.5 LH	30	11	9	24	17.993/17.998	5

\* Not allowed for operation with hydraulic oil.

This series includes additional models. For more information, contact DEUBLIN at +1-847-689-8600 or [www.deublin.com](http://www.deublin.com)

# DEUBLIN

## Rotating Unions Flange Design Bore-Mounted for Various Media



- Single passage available with all sealing technologies
- Accepts up to 19 mm of drawbar movement
- Full-flow design has no obstructions to trap swarf or debris
- Labyrinth system and large vents to protect ball bearings
- Balanced mechanical seals made from silicon carbide for long life even under difficult operating conditions
- Anodised end cap and stainless steel housing and rotor resist corrosion
- Dry run capability depending on sealing technology and materials possible

### Operating Data

Sealing Technology (depending on model)	AutoSense™, Closed Seal, Pop-Off™	
Media (depending on model)	Coolant – water based; Cutting Oil Compressed Air up to 10 bar, up to 145 psi MQL (oil mist) up to 10 bar, up to 145 psi	
Max. Speed	27,000 min <sup>-1</sup>	27,000 rpm

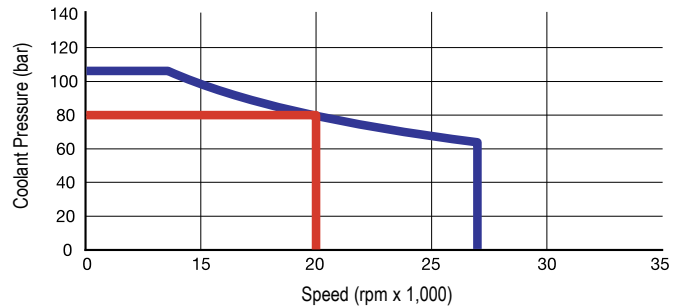

### Flange Connection

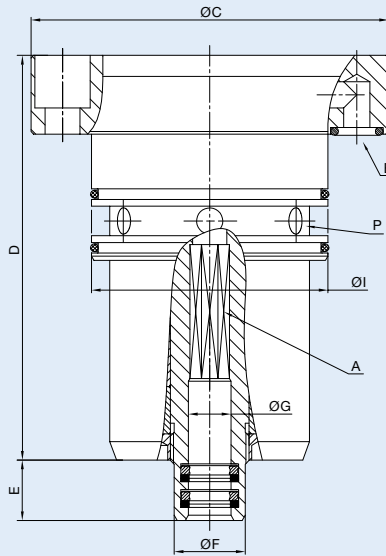

Ordering Number	Sealing Technology	B Supply Connection	C Overall Diameter	D Overall Length	P Drain Size Ø	A Rotor Connection	E Rotor Length	F Rotor OD	G Bore Diameter	I Pilot Diameter	Max. Speed (rpm)	Max. Pressure (bar)
1108-310-304	Closed Seal	Ø5 Flange	84	84	4x Ø5	Hexagon 11	34	24	14.1H7	49 f7	20,000	80
1114-935-793	AutoSense™	Ø5 Flange	68	77	6x Ø5	Octagon 7.4 D10	11.5	13.5	8.1F9	45 h7	27,000	105

This series includes additional models. For more information, contact DEUBLIN at +1-847-689-8600 or [www.deublin.com](http://www.deublin.com)

# DEUBLIN

## 1117 Series Bearingless "Closed Seal" Rotating Unions for Continuous Coolant Service

- Single passage for coolant or MQL
- Closed seals for transfer line and similar applications
- Full-flow design has no obstructions to trap chips or debris
- Balanced mechanical seals made from silicon carbide for long life even under difficult operating conditions
- Compact size can be adapted for custom installations
- Anodized aluminum housing resists corrosion



### Operating Data

Media	Water-based Coolant MQL (oil mist) up to 10 bar (145 psi)		
Filtration	ISO 4406 Class 17/15/12, max. 60 micron		
Maximum Speed	See table		
Maximum Pressure	See Chart		
Maximum Flow	82 l/min	21.6 gpm	Standard
	24.3 l/min	6.4 gpm	High Pressure (HP)
	2.7 l/min	0.7 gpm	Very High Pressure (VHP)
Maximum Temperature	71°C	160°F	

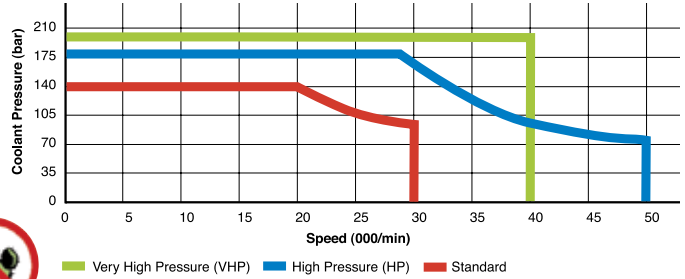

DO NOT RUN DRY

### Axial Connection

### Radial Connection

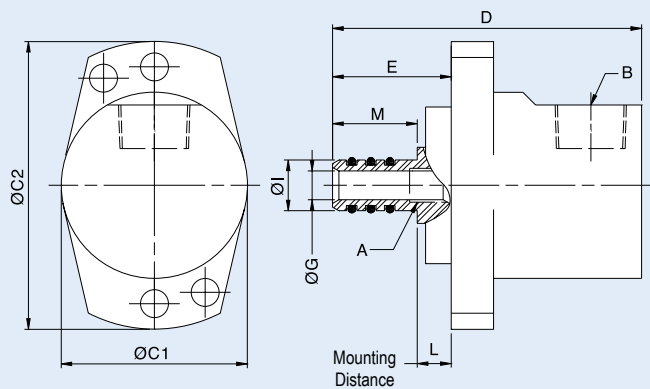
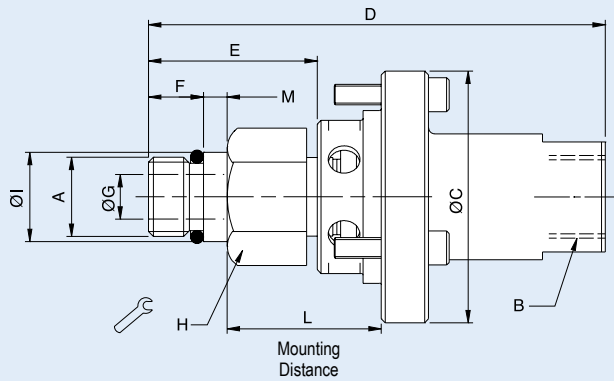

	Ordering Number	B Supply Connection	C Overall Diameter	D Overall Length	L Mounting Distance	A Rotor Connection	E Rotor Length	G Bore Diameter	H Across Flats	I Pilot Diameter	M Pilot Length	Max Speed (rpm)
Radial	1117-706	G 3/8"	44	72	7.5 / 7.0	12f7	21	7	NA	11.984 / 11.966	20	10,000*
	1117-711	3/8" NPT	44 x 68	73	8.0 / 7.5	12f7	28	7	NA	11.984 / 11.966	20	10,000*
	1117-792	G 3/8"	44	72	7.5 / 7.0	12f7	21	7	NA	11.984 / 11.966	20	30,000
Standard Axial Connection	1117-002-110	3/8" NPT	51	95	31.7 / 30.5	5/8"-18 UNF RH	37	9	15/16"	0.6555" / 0.6553"	5	30,000
	1117-002-111	3/8" NPT	51	95	31.7 / 30.5	5/8"-18 UNF LH	37	9	15/16"	0.6555" / 0.6553"	5	30,000
	1117-002-116	3/8" NPT	51	92	31.7 / 30.5	M16 x 1.5 LH	34	9	24	17.993 / 17.988	5	30,000
	1117-058-116	G 3/8"	51	92	31.7 / 30.5	M16 x 1.5 LH	34	9	24	17.993 / 17.988	5	30,000
HP Axial Connection	1117-490-493	3/8" PT	54	105	39.6 / 38.6	M12 x 1.25 LH	40	5	18	14.000 / 13.995	5	50,000
	1117-063-294	G 1/4"	51	92	31.7 / 30.5	M16 x 1.5 LH	34	5	24	17.993 / 17.988	5	40,000

\* Union includes integral lip seal for added spindle protection.

This series includes additional models. For more information, contact DEUBLIN at +1-847-689-8600 or [www.deublin.com](http://www.deublin.com)





# DEUBLIN

## Bearingless Rotating Union Cartridge Design Compact Bearingless Rotating Union for smallest installation space

- Single passage available with almost all sealing technologies
- Design with additional functions: e.g. long stroke stator with hub to allow drawbar movement even when rotating union is mounted onto the clamping unit
- Full-flow design has no obstructions to trap swarf or debris
- Balanced mechanical seals made from silicon carbide / carbon graphite for timed dry run for long life
- Anodised aluminium housing resists corrosion
- Dry run capability depending on sealing technology and materials
- Closed seal, Pop-Off, and AutoSense sealing technologies available depending on model

### Operating Data

Sealing Technology  
(depending on model)

AutoSense®, Closed Seal, Pop-Off®

Media  
(depending on model)

Coolant – water-based;  
Cutting Oil  
Compressed Air up to 10 bar, up to 145 psi  
MQL (oil mist) up to 10 bar, up to 145 psi

### Examples

1121-251-434

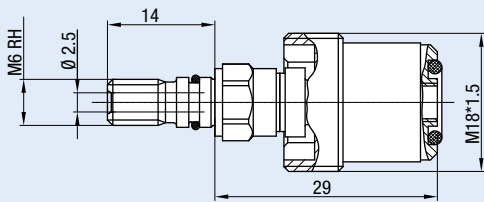

1117-593-589

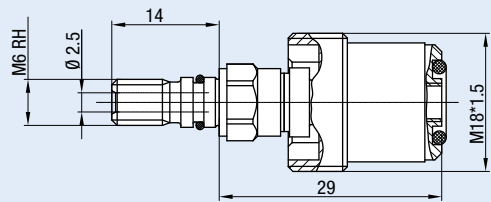

1121-251-434		1117-593-589																					
<b>Features</b> <ul style="list-style-type: none"> <li>• Pop-Off®</li> <li>• Single passage</li> <li>• Seals SIC/SIC</li> </ul>	<b>Operating Data</b> <table> <tr><td>Speed</td><td>150,000 rpm</td></tr> <tr><td>Pressure</td><td>180 bar</td></tr> <tr><td>Media</td><td>Coolant / Cutting Oil</td></tr> <tr><td>Dry run</td><td>Yes</td></tr> <tr><td>Max. Flow</td><td>7.4 l/min</td></tr> </table>	Speed	150,000 rpm	Pressure	180 bar	Media	Coolant / Cutting Oil	Dry run	Yes	Max. Flow	7.4 l/min	<b>Features</b> <ul style="list-style-type: none"> <li>• Closed Seal</li> <li>• Single passage</li> <li>• Seals CG/SIC</li> </ul>	<b>Operating Data</b> <table> <tr><td>Speed</td><td>30,000 rpm</td></tr> <tr><td>Pressure</td><td>140 bar</td></tr> <tr><td>Media</td><td>Coolant / Cutting Oil</td></tr> <tr><td>Dry run</td><td>No</td></tr> <tr><td>Max. Flow</td><td>7.4 l/min</td></tr> </table>	Speed	30,000 rpm	Pressure	140 bar	Media	Coolant / Cutting Oil	Dry run	No	Max. Flow	7.4 l/min
Speed	150,000 rpm																						
Pressure	180 bar																						
Media	Coolant / Cutting Oil																						
Dry run	Yes																						
Max. Flow	7.4 l/min																						
Speed	30,000 rpm																						
Pressure	140 bar																						
Media	Coolant / Cutting Oil																						
Dry run	No																						
Max. Flow	7.4 l/min																						

1124-259-260

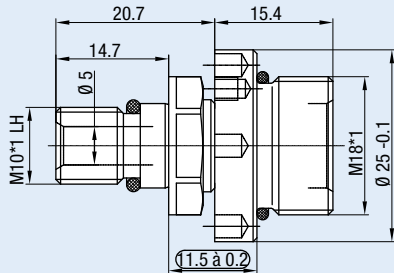

1154-170-137

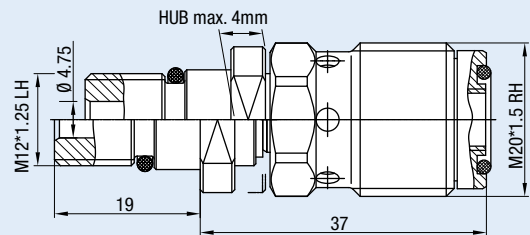

1124-259-260		1154-170-137																					
<b>Features</b> <ul style="list-style-type: none"> <li>• AutoSense®</li> <li>• Single passage</li> <li>• Seals SIC/SIC</li> </ul>	<b>Operating Data</b> <table> <tr><td>Speed</td><td>30,000 rpm</td></tr> <tr><td>Pressure</td><td>140 bar / 10 bar</td></tr> <tr><td>Media</td><td>Coolant / Compressed Air</td></tr> <tr><td>Dry run</td><td>Yes</td></tr> <tr><td>Max. Flow</td><td>7.4 l/min</td></tr> </table>	Speed	30,000 rpm	Pressure	140 bar / 10 bar	Media	Coolant / Compressed Air	Dry run	Yes	Max. Flow	7.4 l/min	<b>Features</b> <ul style="list-style-type: none"> <li>• AutoSense®</li> <li>• Single passage</li> <li>• Seals SIC/SIC</li> <li>• Max Stroke 4 mm</li> </ul>	<b>Operating Data</b> <table> <tr><td>Speed</td><td>40,000 rpm</td></tr> <tr><td>Pressure</td><td>140 bar / 10 bar</td></tr> <tr><td>Media</td><td>Coolant / Compressed Air</td></tr> <tr><td>Dry run</td><td>Yes</td></tr> <tr><td>Max. Flow</td><td>7.4 l/min</td></tr> </table>	Speed	40,000 rpm	Pressure	140 bar / 10 bar	Media	Coolant / Compressed Air	Dry run	Yes	Max. Flow	7.4 l/min
Speed	30,000 rpm																						
Pressure	140 bar / 10 bar																						
Media	Coolant / Compressed Air																						
Dry run	Yes																						
Max. Flow	7.4 l/min																						
Speed	40,000 rpm																						
Pressure	140 bar / 10 bar																						
Media	Coolant / Compressed Air																						
Dry run	Yes																						
Max. Flow	7.4 l/min																						

This series includes additional models. For more information, contact DEUBLIN at +1-847-689-8600 or [www.deublin.com](http://www.deublin.com)

# DEUBLIN

## 1121 Series Bearingless Pop-Off® “Micro Stroke” Rotating Unions for Coolant Service

- Single passage for coolant or MQL
- Patented Pop-Off™ technology allows unlimited dry running without media pressure
- Ultra-short 0.1 mm pop-off stroke restricts drainage of residual coolant during tool change
- Full-flow design has no obstructions to trap chips or debris
- Balanced mechanical seals made from silicon carbide for long life even under difficult operating conditions
- Anodized aluminum housing resists corrosion



### Operating Data

Media	Water-based Coolant MQL (oil mist) up to 10 bar (145 psi)		
Filtration	ISO 4406 Class 17/15/12, max. 60 micron		
Maximum Speed	40,000 min <sup>-1</sup> 50,000 min <sup>-1</sup>	40,000 rpm 50,000 rpm	Standard High Pressure (HP)
Maximum Pressure	140 bar	2,030 psi	
Maximum Flow	24.3 l/min 1121-330-327 1121-330-345	6.4 gpm 10.2 gpm 21.6 gpm	
Maximum Temperature	71°C	160°F	



**NO AIR PRESSURE  
WITH ROTATION**

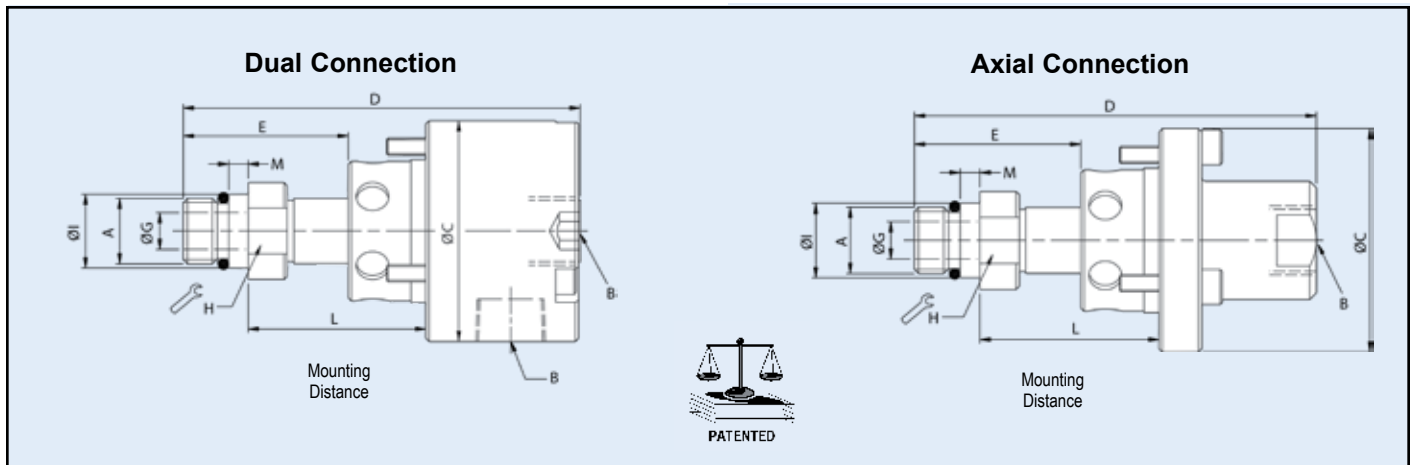
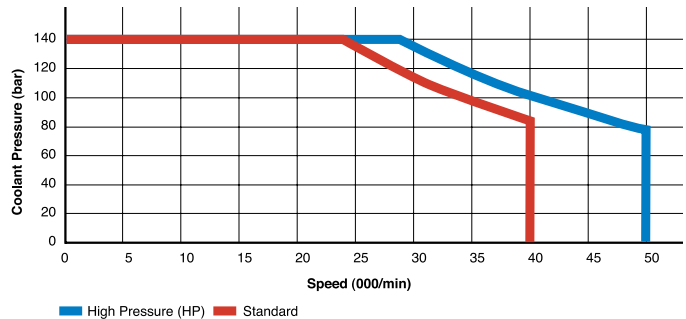

	Ordering Number	B Supply Connection	C Overall Diameter	D Overall Length	L Mounting Distance	A Rotor Connection	E Rotor Length	G Bore Diameter	H Across Flats	I Pilot Diameter	M Pilot Length	Max Speed (rpm)
Standard	1121-300-327	3/8" PT	54	94	39.6 / 38.6	M12 x 1.25 LH	37	6	18	14.000 / 13.995	5	40,000
	1121-300-345	3/8" PT	54	97	44.0 / 43.0	M16 x 1.5 LH	40	9	21	17.993 / 17.988	5	40,000
	1121-330-327	3/8" PT	54	94	39.6 / 38.6	M12 x 1.25 LH	37	6	18	14.000 / 13.995	5	40,000
	1121-330-345	3/8" PT	54	97	44.0 / 43.0	M16 x 1.5 LH	40	9	21	17.993 / 17.988	5	40,000
	1121-380-327	G 3/8" Radial 1/4" PT Axial	54	98	39.6 / 38.6	M12 x 1.25 LH	37	6	18	14.000 / 13.995	5	40,000
	1121-380-345	G 3/8" Radial 1/4" PT Axial	54	102	44.0 / 43.0	M16 x 1.5 LH	40	9	21	17.993 / 17.988	5	40,000
HP	1121-400-327	3/8" PT	54	94	39.6 / 38.6	M12 x 1.25 LH	37	6	18	14.000 / 13.995	5	40,000
	1121-400-345	3/8" PT	54	98	44.0 / 43.0	M16 x 1.5 LH	40	9	21	17.993 / 17.988	5	40,000
	1121-410-493	3/8" PT	54	105	39.6 / 38.6	M12 x 1.25 LH	40	5	18	14.000 / 13.995	5	50,000
	1121-430-431	3/8" PT	54	108	44.0 / 43.0	M16 x 1.5 LH	43	5	21	17.993 / 17.988	5	50,000

**This series includes additional models. For more information, contact DEUBLIN at +1-847-689-8600 or [www.deublin.com](http://www.deublin.com)**



# DEUBLIN

## 1124 Series Bearingless AutoSense® Rotating Unions for Coolant and Air Service with Dry Running

- Single passage for coolant and compressed air
- Patented AutoSense® technology, changes automatically between closed seals and controlled leakage, depending on media
- Full-flow design has no obstructions to trap swarf or debris
- Balanced mechanical seals made from silicon carbide for long life even under difficult operating conditions
- Anodised aluminium housing, resists corrosion
- Available with threaded rotor only

### Operating Data

Media	Water-based Coolant MQL (oil mist) up to 10 bar (145 psi)	
Filtration	ISO 4406 Class 17/15/12, max. 60 micron	
Max. Speed	see graphic/table	
Max. Pressure	see graphic/table	
Max. Flow	37.5 L/min	9.9 gpm
1124-014-015	21.8 L/min	5.8 gpm
1124-800-780	21.8 L/min	5.8 gpm
1124-850-847	19.0 L/min	5.0 gpm
Max. Temperature	71 °C	160 °F

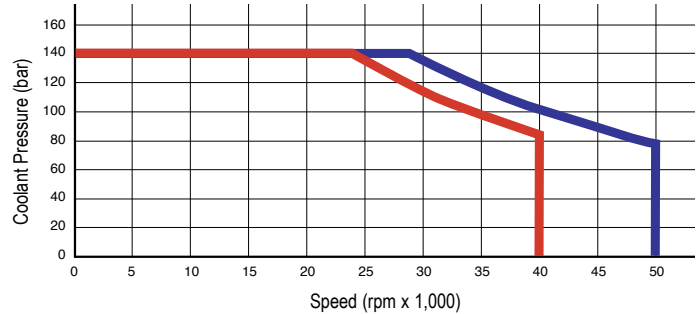

### Dual Connection

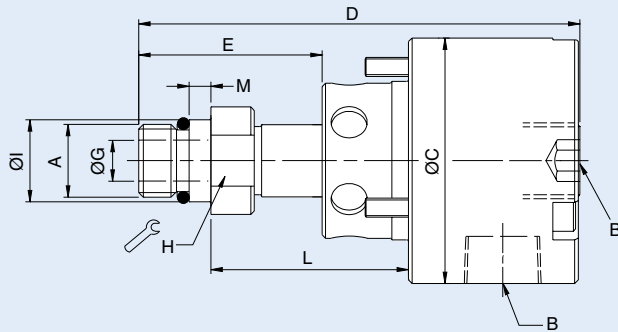

### Axial Connection

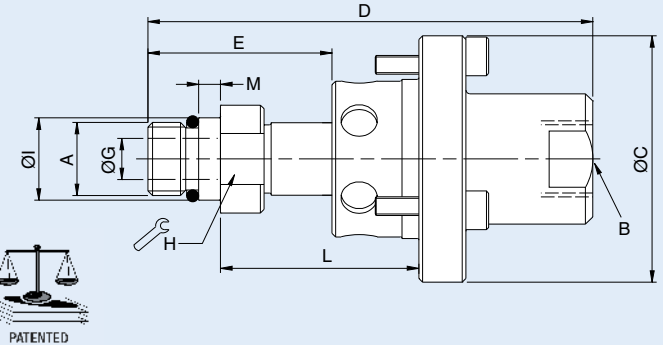

Ordering Number	B Supply Connection	C Overall Diameter	D Overall Length	L Mounting Distance	A Rotor Connection	E Rotor Length	G Bore Diameter	H Across Flats	I Pilot Diameter	M Pilot Length	Max. Speed (rpm)
1124-850-847	G 1/4" Radial	68	101	2	M8 x 0.5 LH	28	4	13	8.995 / 8.991	20	40,000
1124-031-590	G 3/8" Radial	58	76	21.5	M16 x 1.5 LH	25	9	19	17.993 / 17.988	5	40,000
1124-036-301	PT 3/8" Axial	54	97	44.0 / 43.0	M16 x 1.5 LH	40	9	24	17.993 / 17.988	5	40,000
1124-400-327	PT 3/8" Axial	54	94	39.6 / 38.6	M12 x 1.25 LH	37	6	18	14.000 / 13.995	5	40,000
1124-300-327	PT 3/8" Radial	54	94	39.6 / 38.6	M12 x 1.25 LH	37	6	18	14.000 / 13.995	5	40,000
	PT 3/8" Axial										
1124-300-301	PT 3/8" Radial	54	97	44.0 / 43.0	M16 x 1.5 LH	40	9	24	17.993 / 17.988	5	40,000
	PT 3/8" Axial										
1124-800-780	G 3/8" Radial	54	106	41.5	M16 x 1.5 LH	16	5	19	17.993 / 19.988	5	40,000
	G 3/8" Axial										
1124-014-015	G 1/4" Axial	45	63	14	M10 x 1 LH	29	5	14	10.994 / 10.989	7	50,000

This series includes additional models. For more information, contact DEUBLIN at +1-847-689-8600 or [www.deublin.com](http://www.deublin.com)

# DEUBLIN

## 1151 Series Bearingless Pop-Off® "Long Stroke" Rotating Unions for Coolant Service

- Single passage for Coolant and MQL
- Patented Pop-Off technology allows unlimited dry running without media pressure
- Non-rotating element has "stroke" (axial movement) of up to 13.5 mm, to track drawbar movement even when the union is mounted on the clamping device
- Full flow design has no obstructions to trap chips or debris
- Balanced mechanical seals made from silicon carbide for long life even under difficult operating conditions

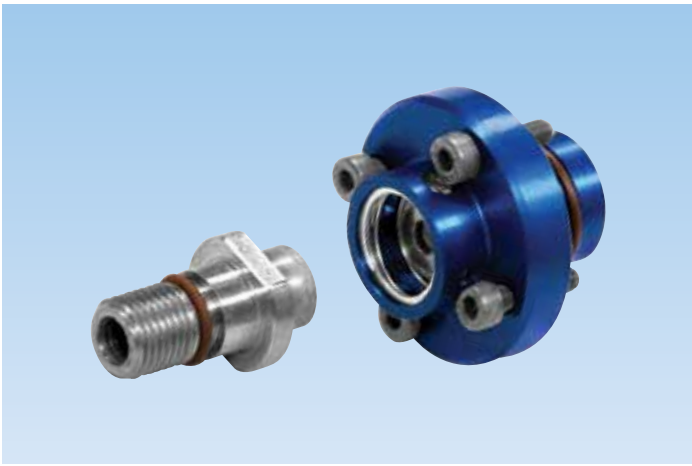

### Operating Data

Media	Water-based Coolant MQL	
Filtration	ISO 4406 Class 17/15/12, max. 60 micron	
Maximum Speed	50,000 min <sup>-1</sup>	50,000 rpm
Maximum Pressure	140 bar	2030 psi
Maximum Flow	33 l/min (6 mm bore)	
Maximum Temperature	71°C	160°F



**NO AIR PRESSURE  
WITH ROTATION**

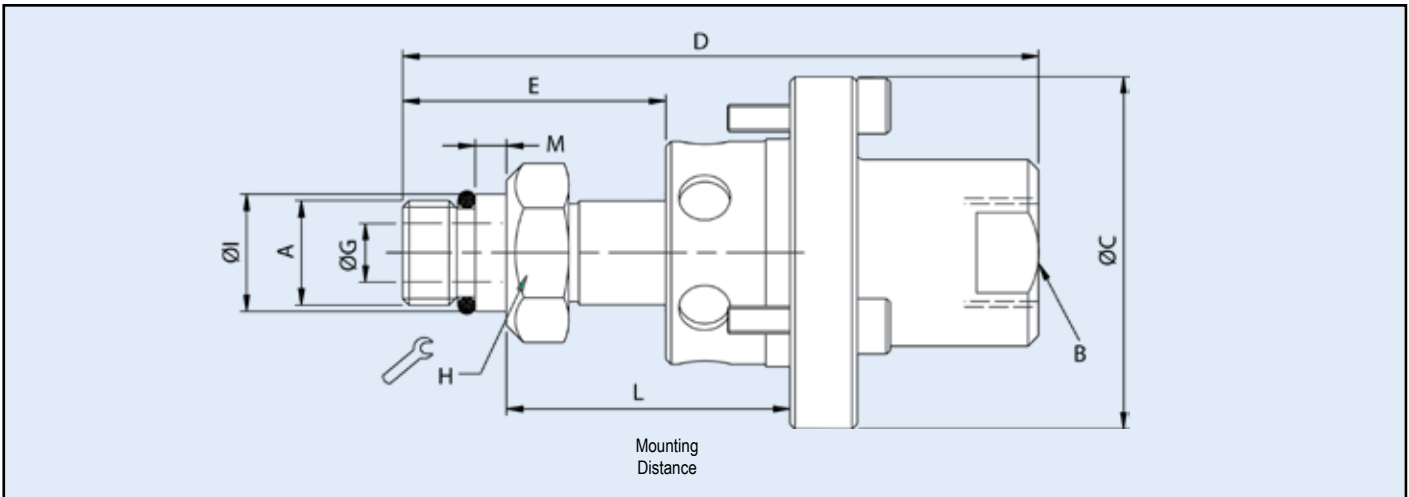
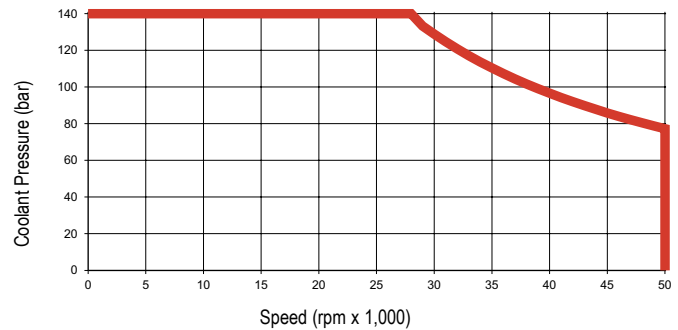

Ordering Number	B Supply Connection	C Overall Diameter	D Overall Length	L Mounting Distance	A Rotor Connection	E Rotor Length	G Bore Diameter	H Across Flats	I Pilot Diameter	M Pilot Length	Max Speed (rpm)
1151-030-137	20.0 mm Counterbore	40.2	62	27.0 / 23.0	M12 x 1.25 LH	32.1	6	17	13.000 / 12.995	6	50,000
1151-031-137	20.0 mm Counterbore	40.2	62	27.0 / 23.1	M12 x 1.25 LH	32.1	6	17	13.000 / 12.996	6	50,000
1151-002-140	16.4 mm Counterbore	31	63	37.0 / 30.0	M12 x 1.25 LH	28	5	15	12.994 / 12.989	6	40,000
1151-020-127	16.0 mm Counterbore	31.8	42	21.5 / 19.5	M10 x 1 LH	23	5	14	10.994 / 10.989	4	50,000
1151-002-133	20.0 mm Counterbore	38.5	79	30.0 / 23.0	M12 x 1.25 LH	26.9	5	15	12.994 / 12.990	6	40,000

**This series includes additional models. For more information, contact DEUBLIN at +1-847-689-8600 or [www.deublin.com](http://www.deublin.com)**



# DEUBLIN

## 1154 Series Bearingless AutoSense® “Long Stroke” Rotating Unions for Coolant and Air Service with Dry Running

- Single passage for coolant or MQL
- Patent-pending AutoSense® technology automatically changes between closed seals and controlled leakage operation in response to the kind of media
- Non-rotating element has a “stroke” (axial movement) of more than 8 mm, to track drawbar movement even when union is mounted on the clamping device
- Full-flow design has no obstructions to trap chips or debris
- Balanced mechanical seals made from silicon carbide for long life even under difficult operating conditions
- Anodized aluminum housing resists corrosion

### Operating Data

Media	Water-based Coolant MQL (oil mist) up to 10 bar (145 psi) Air up to 10 bar (145 psi)	
Filtration	ISO 4406 Class 17/15/12, max. 60 micron	
Maximum Speed	40,000 min <sup>-1</sup>	40,000 rpm
Maximum Pressure	140 bar	2,030 psi
Maximum Flow	24.3 l/min	6.4 gpm
Maximum Temperature	71°C	160°F

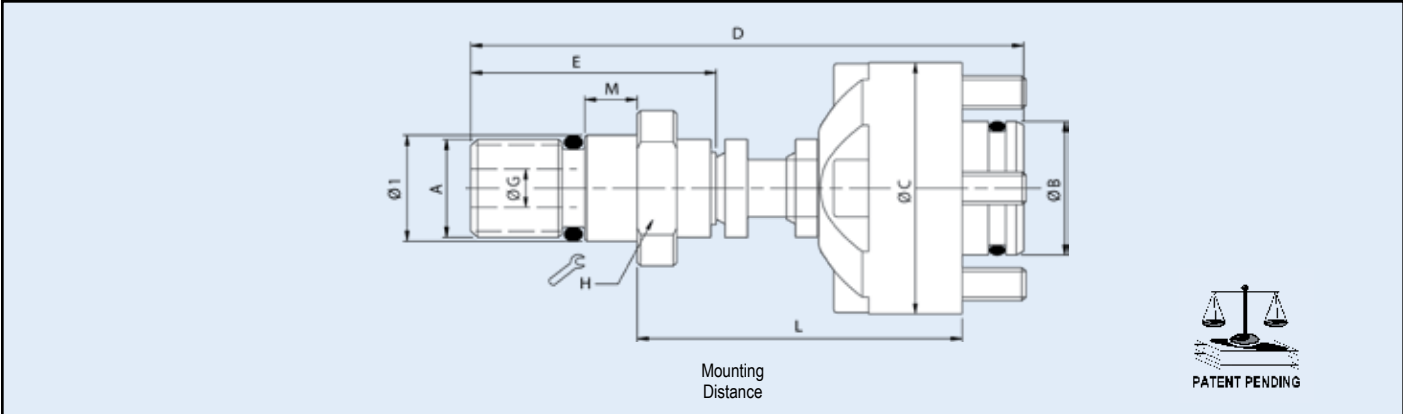
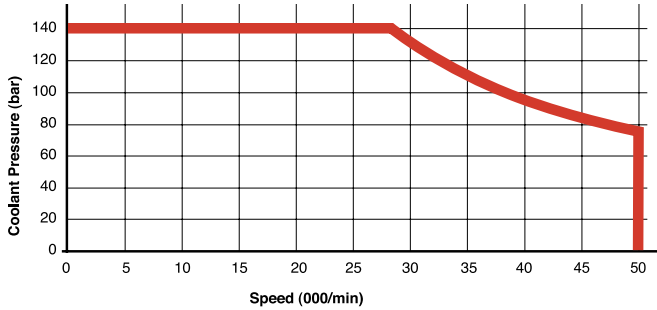

	Ordering Number	B Supply Connection	C Overall Diameter	D Overall Length	L Mounting Distance	A Rotor Connection	E Rotor Length	G Bore Diameter	H Across Flats	I Pilot Diameter	M Pilot Length	Max Speed (rpm)
Axial	1154-002-105	16.4 mm Counterbore	31	72	49.0 / 42.0	M8 x 1 RH	37	4	15	8.995 / 8.991	3.5	40,000
	1154-002-109	16.4 mm Counterbore	31	63	37.0 / 30.0	M12 x 1 RH	28	5	15	12.994 / 12.989	6	40,000
	1154-002-133	16.4 mm Counterbore	31	65	37.0 / 30.0	M16 x 1.5 LH	30	4	19	17.994 / 17.989	6	40,000
	1154-002-140	16.4 mm Counterbore	31	63	37.0 / 30.0	M12 x 1.25 LH	28	5	15	12.994 / 12.989	6	40,000
	1154-003-107	20 mm Counterbore	39	71	40.0 / 33.0	M12 x 1.25 LH	36	5	15	12.994 / 12.989	6	40,000
	1154-003-137	20 mm Counterbore	38.5	62	31.0 / 25.0	M12 x 1.25 LH	27	5	15	12.994 / 12.989	6	40,000
	1154-004-109	30 mm Counterbore	48.5	69	40.5 / 33.5	M12 x 1 RH	28	5	15	12.994 / 12.989	6	40,000
	1154-005-109	16.4 mm Counterbore	31	87	49.0 / 42.0	M12 x 1 RH	28	5	15	12.994 / 12.989	6	40,000
	1154-012-109*	16.4 mm Counterbore	31	63	37.0 / 30.0	M12 x 1 RH	28	5	15	12.994 / 12.989	6	40,000
	1154-012-133*	16.4 mm Counterbore	31	65	37.0 / 30.0	M16 x 1.5 RH	30	5	19	17.994 / 17.989	6	40,000

\* 1154-012-xxx include a spring to fully retract the non-rotating element when pressure is discontinued.

Note: Overall Length (D) is at maximum Mounting Distance (L).

This series includes additional models. For more information, contact DEUBLIN at +1-847-689-8600 or [www.deublin.com](http://www.deublin.com)



# DEUBLIN

## 1139 Series Bearingless "All-Media" Rotating Unions for Coolant, MQL, and Air Service

- Single passage for all media
- Patented technology operates with closed seals for coolant, as a Pop-Off® when pressure is removed, and as with a microscopic gap between the seals ("controlled leakage") with pressurized dry air
- Non-rotating element has a "stroke" (axial movement) of 0.7-3.0 mm, for reliable sealing even with thermal expansion of spindle and variations in drawbar position
- Full-flow design has no obstructions to trap chips or debris
- Balanced mechanical seals made from silicon carbide for long life even under difficult operating conditions
- Anodized aluminum housing resists corrosion



### Operating Data

Media	Water-based Coolant MQL (oil mist) Air, dry or lubricated		
Filtration	ISO 4406 Class 17/15/12, max. 60 micron		
Maximum Speed	30,000 min <sup>-1</sup>	30,000 rpm	
Maximum Pressure	140 bar	2,030 psi	Coolant
	10 bar	145 psi	MQL, Air
Maximum Flow	28 l/min	7.4 gpm	
Maximum Temperature	71°C	160°F	

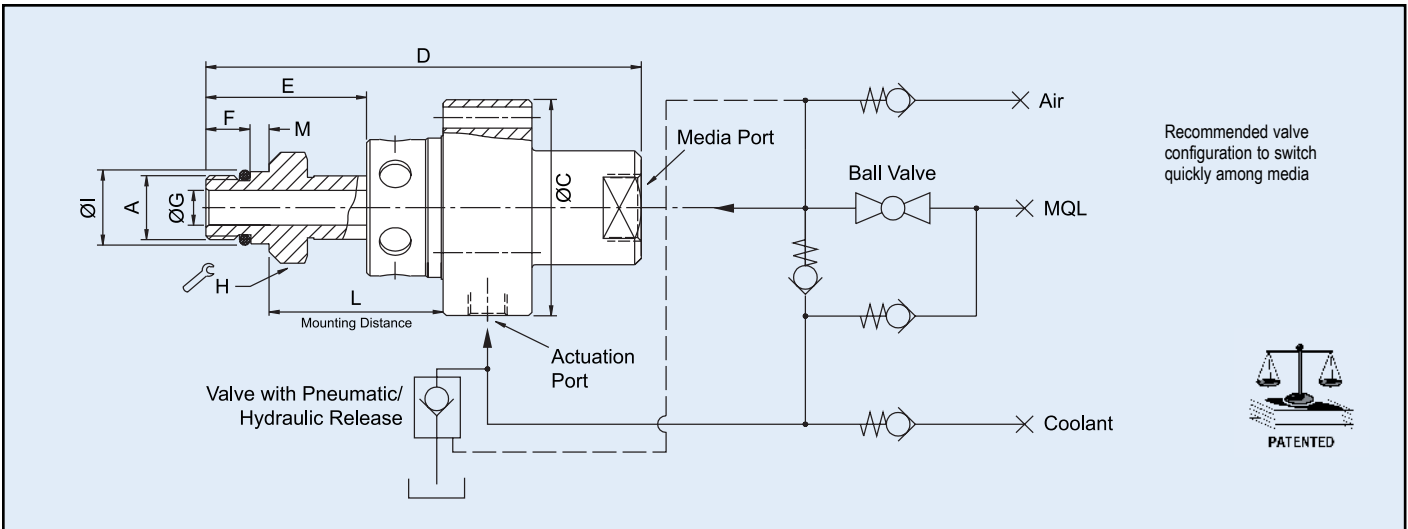
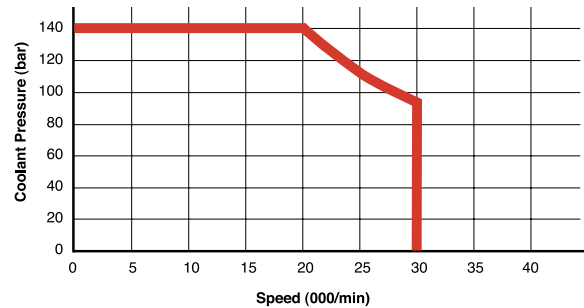

	Ordering Number	B Supply Connection <sup>A</sup>	C Overall Diameter	D Overall Length	L Mounting Distance	A Rotor Connection	E Rotor Length	F Thread Length	G Bore Diameter	H Across Flats	I Pilot Diameter	M Pilot Length
Axial Connection	1139-020-116	3/8" NPT Axial 1/8" NPT Radial	51	97	31.6 / 30.6	M16 x 1.5 LH	28	11	9	24	17.993 / 17.988	5
	1139-032-301	3/8" PT Axial 1/8" PT Radial	54	109	44.0 / 43.0	M16 x 1.5 LH	40	11	9	24	17.993 / 17.988	5
	1139-032-327	3/8" PT Axial 1/8" PT Radial	54	106	39.6 / 38.6	M12 x 1.25 LH	37	12	6	21	14.000 / 13.995	5
	1139-041-301	3/8" PT Axial 1/8" PT Radial	54	109	44.0 / 43.0	M16 x 1.5 LH	40	11	9	24	17.993 / 17.988	5
	1139-744-301	G 3/8" Axial G 1/8" Radial	54	101	44.0 / 43.0	M16 x 1.5 LH	40	11	9	24	17.993 / 17.988	5
Radial	1139-746-301	G 3/8" Radial G 1/8" Radial	54	108	44.0 / 43.0	M16 x 1.5 LH	40	11	9	24	17.993 / 17.988	5
	1139-746-327	G 3/8" Radial G 1/8" Radial	54	105	44.0 / 43.0	M12 x 1.25 LH	37	12	6	24	14.000 / 13.995	5

Note: All 1139 series have a 1/8" radial connection for the actuation port.

This series includes additional models. For more information, contact DEUBLIN at +1-847-689-8600 or [www.deublin.com](http://www.deublin.com)

# DEUBLIN

## 1159 Series Bearingless AutoSense® "Long Stroke" Rotating Unions for Coolant and Air Service with CoolControl® Technology



- Single passage for all media
- Patented AutoSense technology automatically changes between closed seals and controlled leakage operation in response to type of media
- Non-rotating element has "stroke" (axial movement) of up to 13.5 mm, to track drawbar movement even when the union is mounted on the clamping device
- CoolControl technology utilizes an air pilot to hold seals closed during axial drawbar movements, thus minimizing coolant leakage during tool change cycles
- Full flow design has no obstructions to trap chips or debris
- Balanced mechanical seals made from silicon carbide for long life even under difficult operating conditions

### Operating Data

Media	Water-based Coolant MQL Air up to 10 bar (145 psi)	
Filtration	ISO 4406 Class 17/15/12, max. 60 micron	
Maximum Speed	50,000 min <sup>-1</sup>	50,000 rpm
Maximum Pressure	210 bar	3,045 psi
Maximum Flow	33 l/min (6 mm bore)	
Maximum Temperature	71°C	160°F

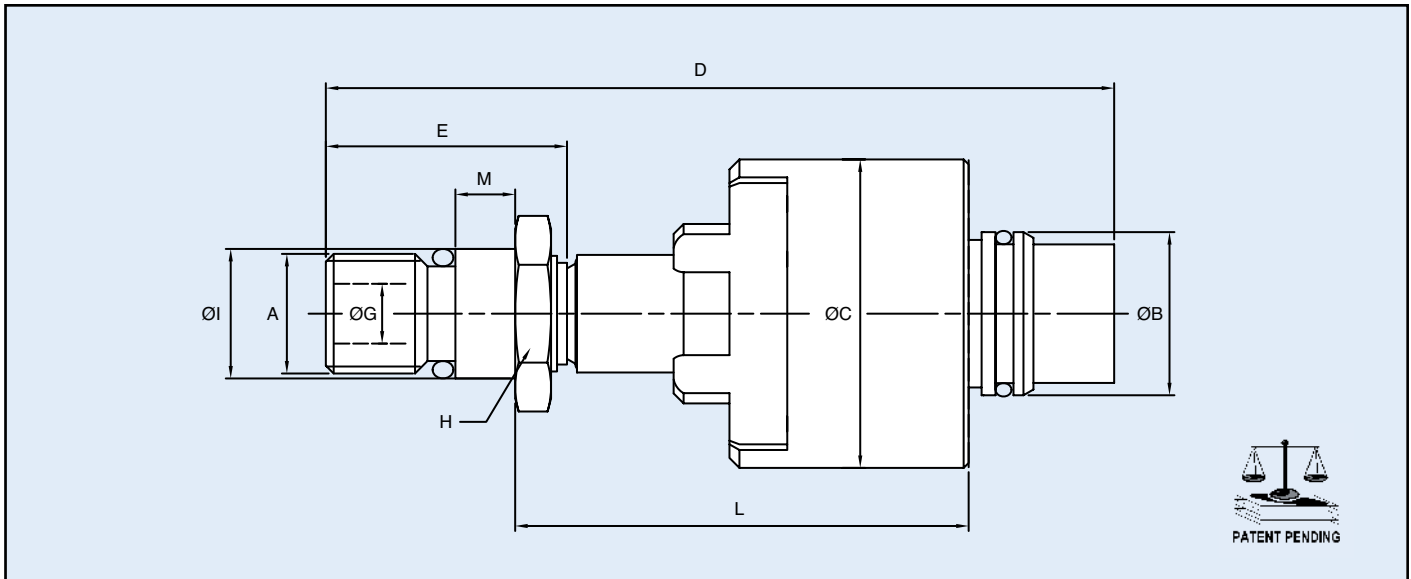
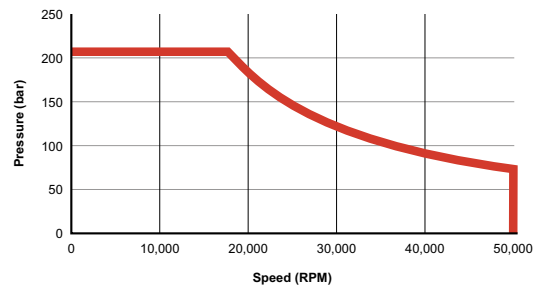

Ordering Number	B Supply Connection	C Overall Diameter	D Overall Length	L Mounting Distance	A Rotor Connection	E Rotor Length	G Bore Diameter	H Across Flats	I Pilot Diameter	M Pilot Length	Max Speed (rpm)
1159-024-105	16.4 mm Counterbore	31	52.9	28.5 / 24.0	M8 x 1 LH	22	4	17	8.995 / 8.991	3.5	50,000
1159-020-101	16.4 mm Counterbore	31	79.3	45.7 / 34.0	M12 x 1 RH	24.2	6	17	12.994 / 12.989	6	50,000
1159-135-103	16.4 mm Counterbore	31	86.1	52.5 / 39.0	M12 x 1.25 LH	24.2	6	17	12.994 / 12.989	6	50,000
1159-003-137	20.0 mm Counterbore	38.5	79	30.0 / 23.0	M12 x 1.25 LH	26.9	5	15	12.994 / 12.990	6	50,000

This series includes additional models. For more information, contact DEUBLIN at +1-847-689-8600 or [www.deublin.com](http://www.deublin.com)

# DEUBLIN

High Flow Rotating Unions for specific applications including Aerospace & machining of special materials

1129-470-511



## Features

- Pop-Off Seals for unlimited unpressurized dry run
- Single passage for coolant or MQL
- M30 x 1.5 LH Rotor
- Housing 34.0 mm counterbore mounting

## Operating Data

Media	Water-based Coolant MQL	
Filtration	ISO 4406 Class 17/15/12, max. 60 micron	
Maximum Speed	10,000 min-1	10,000 rpm
Maximum Pressure	140 bar	2,030 psi
Maximum Flow	276 l/min (16mm bore)	
Maximum Temperature	71°C	160°F



NO AIR PRESSURE  
WITH ROTATION

1110-800-802 and 1110-800-805



## Features

- Pop-Off Seals for unlimited unpressurized dry run
- Single passage for coolant or MQL
- 48 g6 Housing Bore Mounted
- Hexagon 13 D10 Rotor Connection
- G 1/2" radial supply port
- Axial drawbar stroke:  
1110-800-802: 8 mm  
1110-800-805: 18 mm

## Operating Data

Media	Water-based Coolant MQL	
Filtration	ISO 4406 Class 17/15/12, max. 60 micron	
Maximum Speed	17,000 min-1	17,000 rpm
Maximum Pressure	140 bar	2,030 psi
Maximum Flow	200 l/min (12mm bore)	
Maximum Temperature	71°C	160°F



NO AIR PRESSURE  
WITH ROTATION

1110-960-965



## Features

- Pop-Off Seals for unlimited unpressurized dry run
- Single passage for coolant or MQL
- 65 g6 Housing Bore Mounted
- Hexagon 16 D10 Rotor Connection
- 1" NPT RH radial supply port
- Allows drawbar stroke up to 17 mm

## Operating Data

Media	Water-based coolant MQL	
Filtration	ISO 4406 Class 17/15/12, max. 60 micron	
Maximum Speed	5,000 min-1	5,000 rpm
Maximum Pressure	27 bar	390 psi
Maximum Flow	200 l/min (14.3mm bore)	
Maximum Temperature	71°C	160°F



NO AIR PRESSURE  
WITH ROTATION

1110-020-124



## Features

- Pop-Off Seals
- Single passage for coolant or MQL
- M22 x 1.5 RH Rotor Thread Mounted
- 29.993 / 29.980 Rotor Pilot
- G 1/2" radial supply port

## Operating Data

Media	Water-based coolant MQL	
Filtration	ISO 4406 Class 17/15/12, max. 60 micron	
Maximum Speed	8,000 min-1	8,000 rpm
Maximum Pressure	27 bar	390 psi
Maximum Flow	163 l/min (12.7mm bore)	
Maximum Temperature	71°C	160°F



NO AIR PRESSURE  
WITH ROTATION

This series includes additional models. For more information, contact DEUBLIN at +1-847-689-8600 or [www.deublin.com](http://www.deublin.com)

# DEUBLIN

## Special 2-Passage Rotating Unions for MQL Mixed in the Spindle

1112-100-101, 1112-000-165 and 1112-000-343



### Features

- Two concentric passages for mixing oil and air in the spindle
- Rotating inner passage for oil lance
- Threaded rotor for easy installation. M16x1.5LH, 5/8"-18 UNFLH, M12x1.25 LH rotors available
- Full-flow design has no obstructions to trap chips or debris
- Patented AutoSense technology for unlimited dry running without media pressure

### Operating Data

Media	Oil or Water (inner passage) Air (outer passage)	
Filtration	ISO 4406 Class 17/15/12, max. 60 micron	
Maximum Speed	20,000 min <sup>-1</sup>	20,000 rpm
Maximum Pressure		
Oil / Water	62 bar	900 psi
Air	10 bar	145 psi
Maximum Flow	2.3 l/min	0.6 gpm
Maximum Temperature	71°C	160°F

1112-240-001 and 1112-243-001



### Features

- Two concentric passages for mixing oil and air in the spindle
- Rotating inner passage for oil lance
- Bore mounted design for easy installation
- Patented Pop-Off® and AutoSense® technologies allow unlimited dry running without media pressure

### Operating Data

Media	Oil or Coolant (Inner Passage) Air (outer passage)	
Filtration	ISO 4406 Class 17/15/12, max. 60 micron	
Maximum Speed	30,000 min <sup>-1</sup>	30,000 rpm
Maximum Pressure		
Oil / Coolant	140	2030 psi
Air	8 bar	116 psi
Max. Flow	6 l/min	1.6 gpm
Maximum Temperature	71°C	160°F

1122-923-852



### Features

- Two concentric passages for mixing oil and air in the spindle
- Non-rotating inner passage for oil lance
- Bearingless design

### Operating Data

Media	Oil (inner passage) Air (outer passage)	
Filtration	ISO 4406 Class 17/15/12, max. 60 micron	
Maximum Speed	20,000 min <sup>-1</sup>	20,000 rpm
Maximum Pressure		
Oil / Water	12 bar	174 psi
Air	8 bar	116 psi
Maximum Flow	2.3 l/min	0.6 gpm
Maximum Temperature	71°C	160°F

This series includes additional models. For more information, contact DEUBLIN at +1-847-689-8600 or [www.deublin.com](http://www.deublin.com)

# DEUBLIN

## 2620 Series 2-Passage Rotating Unions for Various Media

- Two independent passages for applications such as clamping and unclamping
- Balanced mechanical seals for each passage provide long life and reduced torque even at maximum pressure
- Closed seals provide continuous containment of media
- Dual precision ball bearings for smooth operation
- Labyrinth protection for ball bearings
- Mountings options are compatible with DEUBLIN 2520 or 1579 series unions



### Operating Data

Media	See table	
Filtration	ISO 4406 Class 17/15/12, max. 60 micron	
Maximum Speed	7,000 min <sup>-1</sup>	7,000 rpm
Maximum Pressure	See table	
Maximum Flow	69 l/min	18.2 gpm (per passage)
Maximum Temperature	71°C	160°F

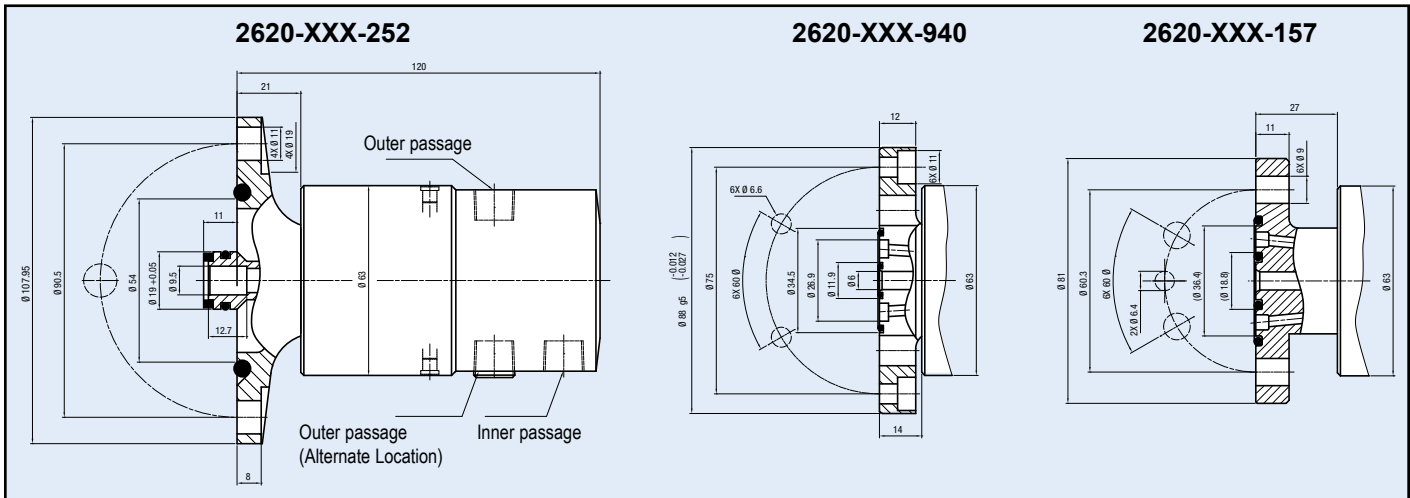
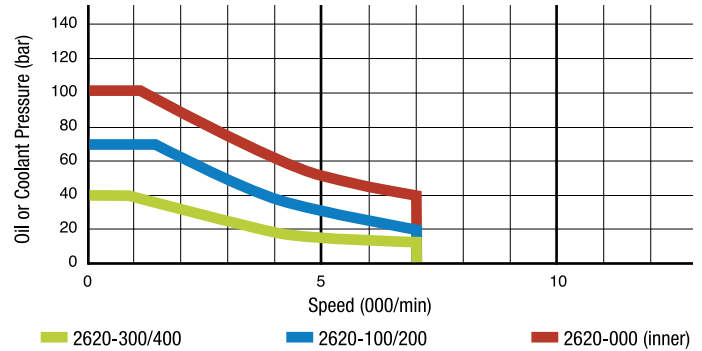

With Ø 108 mm flanged rotor		With Ø 88 mm flanged rotor		With Ø 81 mm flanged rotor		Inner Passage		Outer Passage		Notes
Ordering Number	Supply Connections	Ordering Number	Supply Connections	Ordering Number	Supply Connections	Media	Max. Pressure [bar]	Media	Max. Pressure [bar]	
	Inner and outer Passage		Inner Passage Outer Passage		Inner and outer Passage					
2620-000-252	1/4 NPT	2620-002-940	G 1/4" G 1/4"	2620-000-157	1/4 NPT	Hydraulic Oil	100	Hydraulic Oil	30	
2620-100-252	1/4 NPT	2620-102-940	G 3/8" G 1/8"	2620-100-157	1/4 NPT	Hydraulic Oil	70	Compressed Air	6	Compressed air seals may be lubricated through oil cup or by using oiled compressed air.
2620-120-252	1/4 NPT	2620-122-940	G 3/8" G 1/8"	2620-120-157	1/4 NPT	Hydraulic Oil	70	Compressed Air	10	
2620-200-252	1/4 NPT	2620-202-940	G 3/8" G 1/8"	2620-200-157	1/4 NPT	Coolant	70	Compressed Air	6	
2620-220-252	1/4 NPT	2620-222-940	G 3/8" G 1/8"	2620-220-157	1/4 NPT	Coolant	70	Compressed Air	10	
2620-300-252	1/4 NPT	2620-302-940	G 1/4" G 1/4"	2620-300-157	1/4 NPT	Compressed Air	6	Hydraulic Oil	40	Compressed air seals require no external lubrication.
2620-320-252	1/4 NPT	2620-322-940	G 1/4" G 1/4"	2620-320-157	1/4 NPT	Compressed Air	10	Hydraulic Oil	40	
2620-400-252	1/4 NPT	2620-402-940	G 1/4" G 1/4"	2620-400-157	1/4 NPT	Compressed Air	6	Coolant	40	
2620-420-252	1/4 NPT	2620-422-940	G 1/4" G 1/4"	2620-420-157	1/4 NPT	Compressed Air	10	Coolant	40	
2620-500-252*	1/4 NPT	2620-502-940*	G 3/8" G 1/8"	2620-500-157	1/4 NPT	Compressed Air	6	Compressed Air	6	Consult DEUBLIN regarding maximum speed.
2620-520-252	1/4 NPT	2620-522-940	G 3/8" G 1/8"	2620-520-157	1/4 NPT	Compressed Air	10	Compressed Air	10	

\* Inner passage allowed for operation with hydraulic 70 bar and coolant 70 bar.

This series includes additional models. For more information, contact DEUBLIN at +1-847-689-8600 or [www.deublin.com](http://www.deublin.com)



# DEUBLIN

## 2620 Series 2-Passage Rotating Unions for Various Media



- Two independent passages for applications such as clamping and unclamping, work piece sensing, and cooling
- Balanced mechanical seals for each passage provide long life and reduced torque even at maximum pressure
- Closed seals provide continuous containment of media
- Dual precision ball bearings for smooth operation
- Labyrinth protection for ball bearings
- Mountings options are compatible with DEUBLIN 2520 or 1579 series unions

### Operating Data

Media	See table	
Filtration	ISO 4406 Class 17/15/12, max. 60 micron	
Maximum Speed	12,000 min <sup>-1</sup>	12,000 rpm
Maximum Pressure	See table	
Maximum Flow	69 l/min	18.2 gpm (per passage)
Maximum Temperature	71°C	160°F

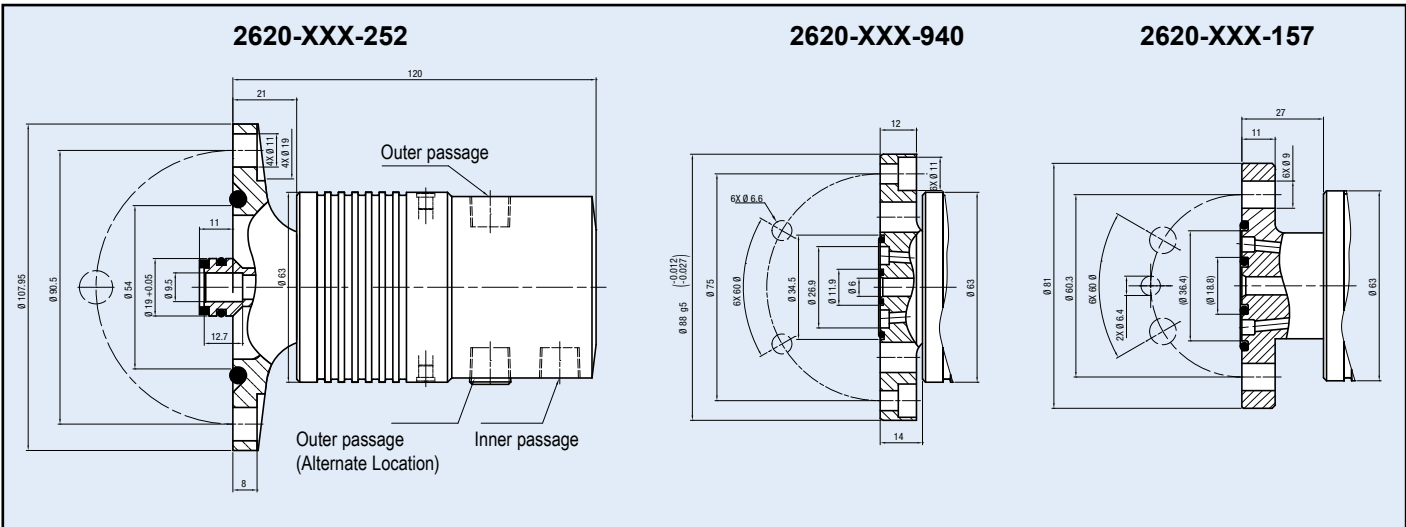
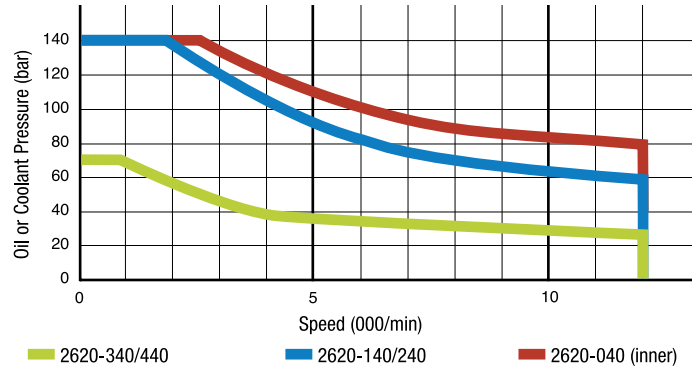

With Ø 108 mm flanged rotor		With Ø 88 mm flanged rotor		With Ø 81 mm flanged rotor		Inner Passage		Outer Passage		Notes
Ordering Number	Supply Connections	Ordering Number	Supply Connections	Ordering Number	Supply Connections	Media	Max. Pressure [bar]	Media	Max. Pressure [bar]	
	Inner and outer Passage		Inner Passage		Outer Passage					Inner and outer Passage
2620-040-252	1/4 NPT	2620-042-940	G 1/4" G 1/4"	2620-040-157	1/4 NPT	Hydraulic Oil	140	Hydraulic Oil	70	
2620-140-252	1/4 NPT	2620-142-940	G 3/8" G 1/8"	2620-140-157	1/4 NPT	Hydraulic Oil	140	Compressed Air	6	Compressed air seals may be lubricated through oil cup or by using oiled compressed air.
2620-160-252	1/4 NPT	2620-162-940	G 3/8" G 1/8"	2620-160-157	1/4 NPT	Hydraulic Oil	140	Compressed Air	10	
2620-240-252	1/4 NPT	2620-242-940	G 3/8" G 1/8"	2620-240-157	1/4 NPT	Coolant	140	Compressed Air	6	
2620-260-252	1/4 NPT	2620-262-940	G 3/8" G 1/8"	2620-260-157	1/4 NPT	Coolant	140	Compressed Air	10	
2620-340-252	1/4 NPT	2620-342-940	G 1/4" G 1/4"	2620-340-157	1/4 NPT	Compressed Air	6	Hydraulic Oil	70	Compressed air seals require no external lubrication.
2620-360-252	1/4 NPT	2620-362-940	G 1/4" G 1/4"	2620-360-157	1/4 NPT	Compressed Air	10	Hydraulic Oil	70	
2620-440-252	1/4 NPT	2620-442-940	G 1/4" G 1/4"	2620-440-157	1/4 NPT	Compressed Air	6	Coolant	70	
2620-460-252	1/4 NPT	2620-462-940	G 1/4" G 1/4"	2620-460-157	1/4 NPT	Compressed Air	10	Coolant	70	

This series includes additional models. For more information, contact DEUBLIN at +1-847-689-8600 or [www.deublin.com](http://www.deublin.com)

# DEUBLIN

## 2630/2640/2650 Series 3 to 5-Passage Rotating Unions for Various Media

- Three to five independent passages for applications such as clamping and unclamping, work piece or tool sensing, and spindle cooling
- Balanced mechanical seals in all passages for low torque and long life even with high speeds and pressures
- Closed seals provide continuous containment of media
- No external lubrication of air seals is required
- Dual precision ball bearings for smooth operation
- Labyrinth protection for ball bearings



### Operating Data

Media	See table	
Filtration	ISO 4406 Class 17/15/12, max. 60 micron	
Maximum Speed	10,000 min <sup>-1</sup>	10,000 rpm
Maximum Pressure		
Coolant or oil	140 bar	2,030 psi
Air	10 bar	145 psi
Maximum Flow Per Passage		
2630 Series	39 l/min	10.2 gpm
2640 Series	17 l/min	4.5 gpm
2650 Series	17 l/min	4.5gpm
Maximum Temperature	71°C	160°F



End View (2630-100-001 shown)

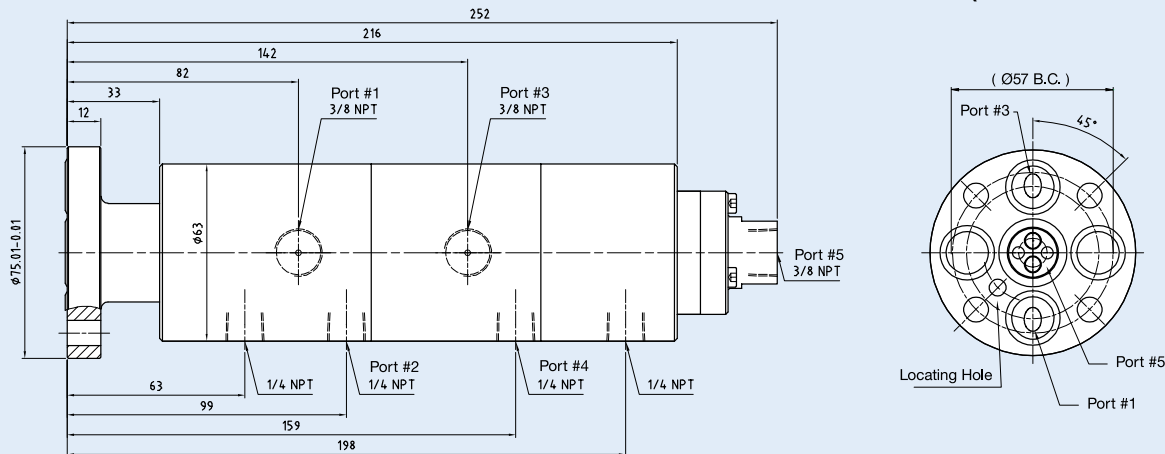

Number of Passages	Ordering Number	Port #1	Port #2	Port #3	Port #4	Port #5
3	2630-000-001	Hydraulic or Cooling Oil	Drain	Water	Drain	Coolant / MQL / Dry Air*
	2630-100-001	Hydraulic or Cooling Oil	Drain	Hydraulic or Cooling Oil	Drain	Coolant / MQL / Dry Air*
	2630-200-001	Hydraulic or Cooling Oil	Air**	Coolant	Drain	NA
	2630-300-001	NA	Air**	Coolant	Air**	NA
	2630-400-001	NA	Air**	Coolant	Drain	Coolant / MQL / Dry Air*
	2630-500-001	Hydraulic or Cooling Oil	Drain	Hydraulic or Cooling Oil	Drain	Hydraulic or Cooling Oil
4	2640-000-001	Hydraulic or Cooling Oil	Air**	Coolant	Drain	Coolant / MQL / Dry Air*
	2640-100-001	Hydraulic or Cooling Oil	Air**	Hydraulic or Cooling Oil	Drain	Coolant / MQL / Dry Air*
	2640-200-001	Hydraulic or Cooling Oil	Air**	Hydraulic or Cooling Oil	Drain	Hydraulic or Cooling Oil
	2640-400-001	Hydraulic or Cooling Oil	Air**	Hydraulic or Cooling Oil	Air**	NA
	2640-600-001	Air**	Air**	Air**	Drain	Coolant / MQL / Dry Air*
5	2650-000-001	Hydraulic or Cooling Oil	Air**	Coolant	Air**	Hydraulic or Cooling Oil
	2650-100-001	Hydraulic or Cooling Oil	Air**	Hydraulic or Cooling Oil	Air**	Air**

\* This passage features AutoSense® technology. With dry air, it operates with controlled leakage with MQL and coolant, it operates with closed seals.

\*\* This passage operates with closed seals, appropriate for tool or work piece sensing applications.

**This series includes additional models. For more information, contact DEUBLIN at +1-847-689-8600 or [www.deublin.com](http://www.deublin.com)**



# DEUBLIN

## Multi-Channel High Speed Unions (1000+ RPM) for DDRT Applications Requiring Various Media

- 3-8 Passages for Various Media
- Applications include clamping and unclamping, work piece or tool sensing, air cleaning, and spindle cooling
- Minimized axial length
- No external lubrication required for air seals
- Balanced mechanical seals in all passages for low torque and long life even with high speeds and pressures
- Closed seals provide continuous containment of media with no by-pass leakage
- Dual precision ball bearings for smooth operation

### Operating Data

Media	Hydraulic Oil Cooling Oil Air up to 10 bar (145 psi) Coolant	
Filtration	ISO 4406 Class 17/15/12, max. 60 micron	
Maximum Speed	See Chart	See Chart
Maximum Pressure		
Coolant or oil	Up to 140 bar	2,030 psi
Air	Up to 10 bar	145 psi
Maximum Temperature	71°C	160°F

#### Rotor-mounted Radial Connection Connection 1

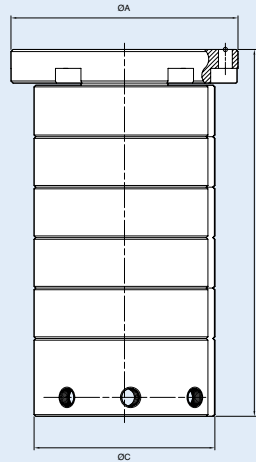

#### Rotor-mounted Axial Connection Connection 2

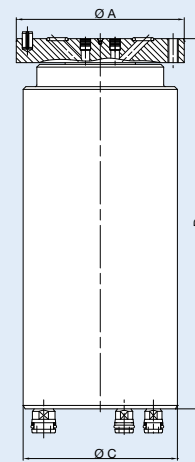

Number of Passages	Connection	Ordering Number	Max Speed	Media Channels	D Overall Length	C Housing Diameter	A Flange Diameter
3	1	2603-140-108	7000	2x Oil, 1x Air	140	68	108
3	1	2603-145-108	7000	2x Oil, 1x Air	140	68	108
3	1	2603-141-108	3000	3x Air	140	68	108
4	1	2604-001-108	3000	2x Oil, 2x Air	164	86	108
4	1	2604-101-108	3000	3x Hydraulic, 1x Air	164	86	108
6	1	2606-100-101	3000	2x Cooling Oil, 2x Hydraulic Oil, 2x Air	205	86	100
6	2	2606-200-101	3000	2x Cooling Oil, 2x Hydraulic Oil, 2x Air	215	86	100
6	1	2606-075-102	3000	2x Cooling Oil, 2x Hydraulic Oil, 2x Air	163	75	75
8	1	2608-158-103	2000	2x Cooling Oil, 3x Hydraulic Oil, 3x Air	252	115	168
8	1	2608-159-103	2000	2x Cooling Oil, 4x Hydraulic Oil, 2x Air	252	115	168

This series includes additional models. For more information, contact DEUBLIN at +1-847-689-8600 or [www.deublin.com](http://www.deublin.com)

# DEUBLIN

## Hybrid-Multi-Passage Series up to 10-Passages for various Media

- Independent channels for various applications, e.g. clamping/unclamping, tool clamping, cooling and work piece sensing
- Combination of various sealing technologies for compact design, high pressures for hydraulic and coolant applications and high flow
- Special balanced sealing technologies for low temperatures and long life
- Various installation options for easy and fast installation through media plug-and-socket connection (*Deublin* tubes)



### Operating Data

Max. Speed	see table	
Max. Pressure		
Hydraulic	up to 200 bar	2,900 psi
Cooling Water	up to 6 bar	87 psi
Coolant	up to 140 bar	2,030 psi
Air, MQL	up to 10 bar	145 psi
Vacuum	up to 0,07 bar absolute	1.015 psi
Max. Temperature	71 °C	160 °F

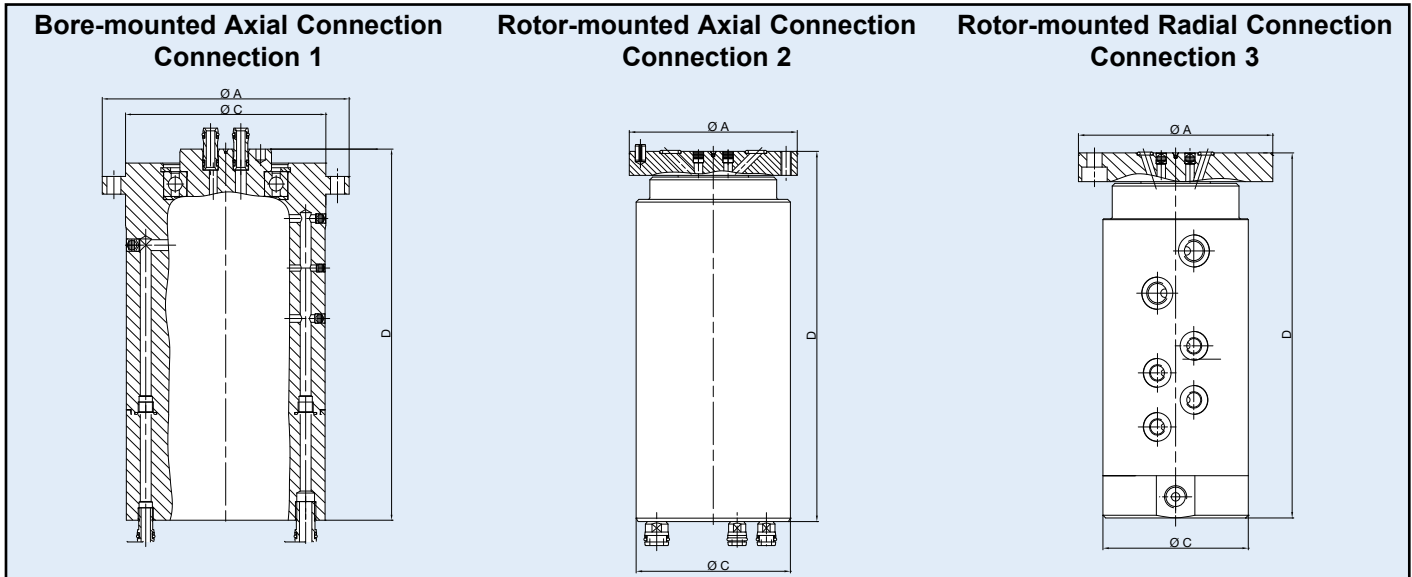

Passages	Connection	Ordering Number	Max. Speed [rpm]	Media	D Overall Length	C Overall Diameter	A Ø Flange
3	3	SP0301	500	3x Compressed Air	128	86	64 f7
3	1	SP0562	500	2x Hydraulic, 1x Compressed Air	147	129	159
4	2	SP0673	1,000	2x Hydraulic, 2x Cooling Water	260	88	85 g6
4	2	SP0575	400	2x Hydraulic, 2x Compressed Air	157	90	98 g7
4	2	SP0570	1,000	4x Hydraulic	157	90	98 g7
4	2	SP0653	1,200	4x Compressed Air when stationary	157	90	98 g7
4	1	SP0599	500	2x Hydraulic, 2x Compressed Air	171	129	159
5	2	SP0664	2,500	3x Hydraulic, 2x Compressed Air	245	110	132 g7
5	2	SP0592	250	4x Hydraulic, 1x Compressed Air	190	90	98 g7
6	3	SP0591	600	2x Hydraulic, 4x Compressed Air	216	86	115 g6
7	1	SP0399	500	5x Hydraulic, 2x Compressed Air	240	129	159
8	2	SP0667	800	5x Hydraulic, 2x Compressed Air, 1x Vacuum	280	115	134 g6
9	2	SP0669	1,000	8x Hydraulic, 1x Compressed Air	332	134	134 g6
10	2	MPSS-000037	35	8x Hydraulic, 2x Compressed Air	342	164	94 f8

This series includes additional models. For more information, contact DEUBLIN at +1-847-689-8600 or [www.deublin.com](http://www.deublin.com)

# DEUBLIN

## 1379 and 1479 Series 4-Passage Rotating Unions for Various Media



- Four independent passages for applications such as clamping and unclamping, work piece or tool sensing, and spindle cooling
- Vent between passages 2 and 3 allows use of two different media without cross contamination. For example, water in passages 1 and 2 and hydraulic oil in passages 3 and 4
- Stainless steel and brass components resist corrosion
- Hardened chrome sealing surface and elastomer-energized seals
- Dual, widely spaced ball bearings absorb large side loads

### Operating Data

Media	Hydraulic oil Air (dry or lubricated)	
Filtration	ISO 4406 Class 17/15/12, max. 60 micron	
Maximum Speed	250 min <sup>-1</sup>	250 rpm
Maximum Pressure		
Hydraulic oil	60 bar	870 psi (rotating)
Air	250 bar	3,625 psi (very slow rotation)
Air	10 bar	145 psi
Maximum Flow Per Passage		
1379 Series	53 l/min	14 gpm
1479 Series	108 l/min	28.5 gpm
Maximum Temperature	80°C	175°F

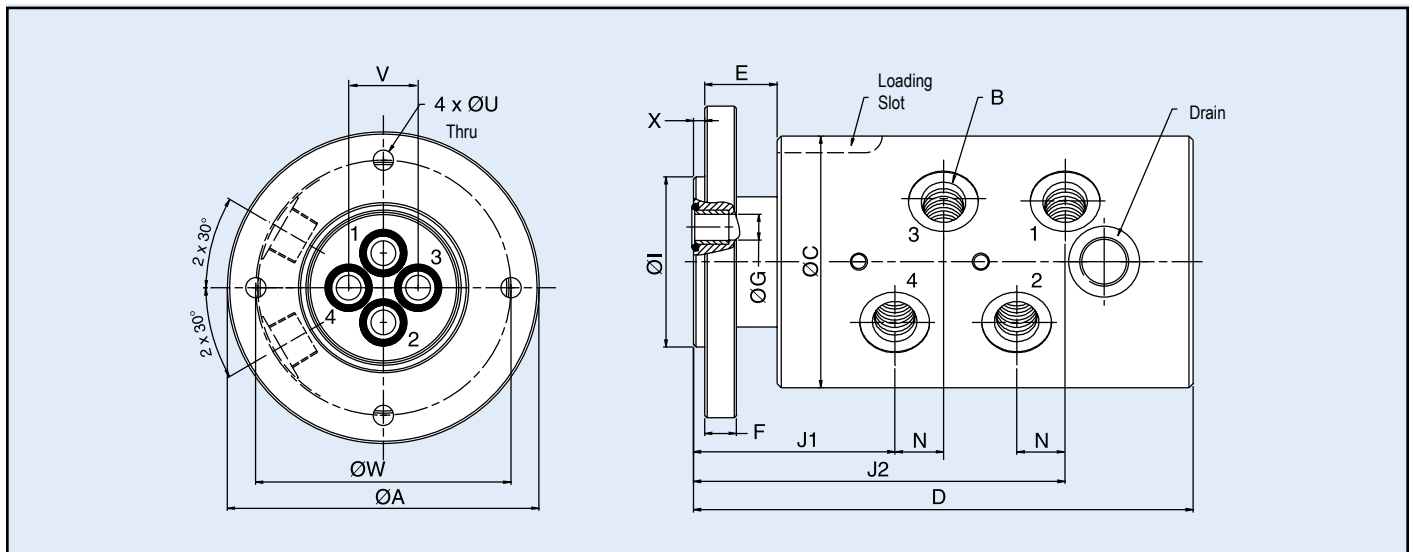
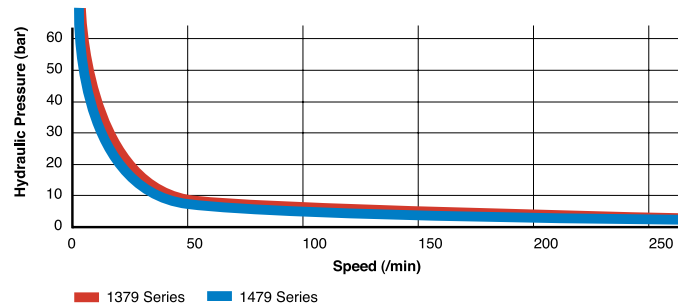

	Ordering Number	B Supply Connection	A Flange Dia.	C Housing Dia.	D Overall Length	E Rotor Length	F Flange Thickness	G Bore Dia.	I Pilot Dia.	J1	J2	N	U	V	W B.C. Ø	X Pilot Length
	1379-460	3/8" NPT	110	89	176	25	10.5	9	60.000 59.981	72	142	17	7.2	24.5	90	4
	1379-160	G 3/8"	110	89	176	25	10.5	9	60.000 59.981	72	142	17	7.2	24.5	90	4
	1479-400	1/2" NPT	130	108	202	25	13.5	13	75.000 74.981	81	169	23	9	29	110	4
	1479-100	G 1/2"	130	108	202	25	13.5	13	75.000 74.981	81	169	23	9	29	110	4

This series includes additional models. For more information, contact DEUBLIN at +1-847-689-8600 or [www.deublin.com](http://www.deublin.com)



# DEUBLIN

## SpindleShield™ Series Unions with Integrated Alert System for Spindle Protection

- Patented SpindleShield system reliably prevents expensive spindle failures by warning machine of leakage due to excessive seal wear
- Rotor mounted, bore mounted, and bearing-less options
- Closed Seal, Pop-Off, and AutoSense sealing options
- Signal can be sent to unused relay on existing I/O board, and unassigned M-code can check status of that relay
- Includes test circuit that can be checked manually or programmed for machine to check automatically

### How it Works

- A** Large or small leakage here is okay, especially with Pop-Off® or AutoSense® seals
- B** Small leakage here one time may be okay. Large or repeating leakage will damage the union's bearings
- C** Even small leakage here can damage the spindle

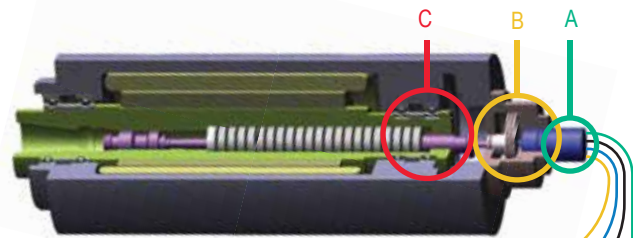

### Operating Data

Media	Water-based Coolant MQL	
Filtration	ISO 4406 Class 17/15/12, max. 60 micron	
Maximum Speed	See Chart	See Chart
Maximum Pressure	140 bar	2,030 psi
Maximum Flow	24.3 l/min	
Maximum Temperature	71°C	160°F

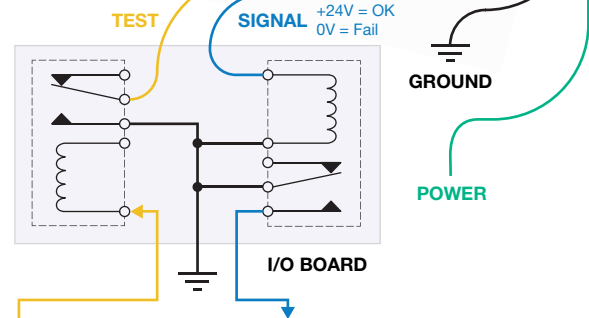
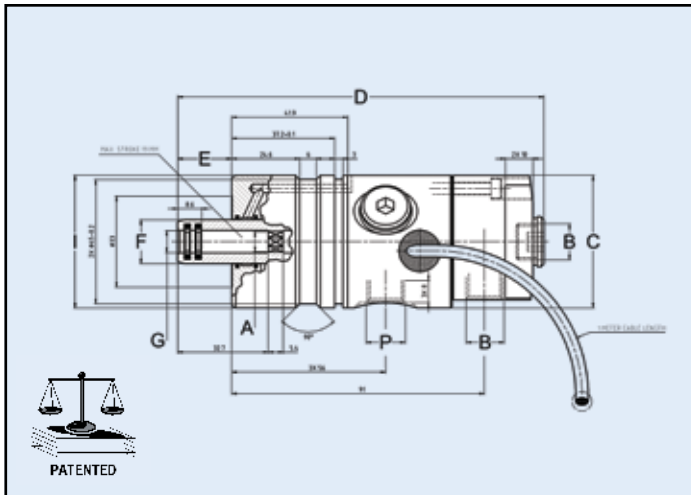

- Self-Test can happen:**
- At machine start-up
  - Monthly
  - Daily
- Program or Macro can:**
- Turn off coolant
  - Stop spindle rotation
  - Call maintenance

Ordering Number	B Supply Connection	C Overall Diameter	D Housing Length	P Vent Size (3 X 120°)	A Rotor Connection	G Bore Diameter	I Pilot Diameter	Max Speed (rpm)	Seal Technology
1103-840-835	G 1/4" Radial/Axial	48	108	G 1/4"	Octagon 7.4 D10	8.1F9	48g6 (housing)	24,000	Pop-Off
1113-840-835	G 1/4" Radial/Axial	48	108	G 1/4"	Octagon 7.4 D10	8.1F9	48 g6 (housing)	24,000	Closed
1103-820-825	G 1/4" Radial/Axial	48	108	G 1/4"	Hexagon 16 D10	11H7	48 g6 (housing)	24,000	Pop-Off
1103-097-212*	G 1/4" Radial	53	142	G 1/4"	M16 x 1.5 LH	9	17.993 / 19.988	20,000	Pop-Off
1153-003-120*	PT 1/4" Radial	54	78	Rc 1/8"	M12 x 1.25 LH	5	12.994 / 12.989	40,000	AutoSense

\*Note: Contact Deublin for IC drawing

This series includes additional models. For more information, contact DEUBLIN at +1-847-689-8600 or www.deublin.com

# WARRANTY AND OTHER IMPORTANT INFORMATION

## Service and Support

Rotating unions are critical to the performance of your machining centers, so Deublin products are designed for maximum reliability. Deublin service is just as reliable. To provide you with local and emergency service, Deublin has a worldwide service network of wholly-owned subsidiaries

and authorized distributors. Whether you need a spare part, new product, technical advice, or help with a design project, Deublin's experienced customer service representatives and application engineers are available to provide immediate assistance.

## Warranty

For a period of one year from the date of shipment, Deublin warrants that the products sold by it are free from defects in materials and workmanship. The liability of DEUBLIN is limited expressly to the replacement or rebuilding of any article, or part thereof, proven defective, when returned to the Deublin Company, transportation prepaid, within a reasonable time after termination of the 365-day warranty period.

This warranty is void if the product is dismantled, modified, altered, or damaged from improper maintenance, side loading,

excessive temperature, abrasive or chemical action, or other abuse. No representative, agent, or employee of Deublin has any authority to modify the terms of this warranty. Deublin will not be responsible for any consequential or resulting damage which may be claimed to have occurred through the sale or use of such products or parts, thereof, which might be defective.

There are no warranties which extend beyond the description contained under this heading, express or implied, including warranties of fitness for a particular purpose.

## Important Notice

The Deublin rotating union is a precision-made piece of equipment and should be handled accordingly. It is a rotating sealing device – not just a plumbing union. Improper use or installation can result in premature leakage or failure. While Deublin unions are of the highest quality and precision, they are “wear and tear” items. It is important that they are periodically inspected and, as the seals wear out, replaced or repaired to avoid the consequences of leakage.

Deublin unions never should be used for applications other than as specified in the catalog. Deublin unions should not be used to convey flammable media (flash point  $\leq 140^{\circ}\text{F}$  or  $60^{\circ}\text{C}$ ) as leakage may result in explosions or fires. Deublin unions should be used in accordance with standard safety guidelines for the media, and in a well-ventilated area. The use of our product on hazardous or corrosive media is strictly forbidden.

For applications other than as stated in the catalog, contact Deublin's Engineering Department for recommendations.

These instructions are provided as general guidelines. They do not contain exhaustive information about the installation, use or maintenance of unions. Purchasers and users of Deublin unions should be certain that they have reviewed Deublin's catalog and have sufficient experience and training in the use of unions before attempting installation or use of Deublin products. The principal responsibility for the safe and effective use of Deublin unions rests with the user and its employees. Deublin will provide, upon request, whatever assistance it can to advise users about the use of its products and about any difficulties or problems which are brought to its attention.

## Factory Testing

All Deublin rotating unions are factory-tested under pressure prior to shipment. This thorough check ensures that each Deublin union performs as intended. Deublin rotating unions can be installed with the confidence that they will operate to your complete satisfaction.

## GETTING TECHNICAL OR DESIGN ASSISTANCE FROM DEUBLIN

Since 1945, Deublin has grown from a small garage shop to the world's largest manufacturer of rotating unions. Today, Deublin's international headquarters is located in Waukegan, Illinois, with manufacturing facilities and sales offices located in 17 countries on four continents. Deublin's state-of-the-art manufacturing facilities feature the latest technologies, including multi-axis CNC, robotics, single point threading, and cylindrical grinding.

Advanced machining techniques and proprietary processes allow Deublin to achieve the most precise tolerances in the industry and to ensure superior performance and union life. Our worldwide distribution network allows machine operators all over the world to specify Deublin unions when purchasing equipment made in another country. We are manufacturers ourselves, so we understand the importance of fast response time to keep your manufacturing process rolling. Wherever you are located, Deublin has a stocking distributor nearby to meet your requirements – quickly.



DEUBLIN Unions making DEUBLIN Unions

This series includes additional models. For more information, contact DEUBLIN at +1-847-689-8600 or [www.deublin.com](http://www.deublin.com)

# ORDERING CHECK LIST

Because rotating unions must accommodate a broad range of speeds, pressures, and media, the Deublin product line includes thousands of standard models. But sometimes even this extensive selection may not meet your specialized needs. That's why we manufacture an ever-growing line of custom unions to meet the particular requirements of world-leading manufacturers. In many situations, we can adapt an existing union design in order to offer a cost-effective solution that meets your exact specifications.



DEUBLIN 2-passage Unions on CNC Turning Center

When you contact us, we will ask a number of questions to make sure that we completely understand your application. These questions may include:

<b>Machine Type</b>	<input type="checkbox"/> CNC Machining Center <input type="checkbox"/> Gun Drilling <input type="checkbox"/> Transfer Line or Flex Line <input type="checkbox"/> Turning Machine <input type="checkbox"/> Grinding <input type="checkbox"/> Multiple Spindle Head <input type="checkbox"/> Other _____
<b>Orientation</b>	<input type="checkbox"/> Horizontal <input type="checkbox"/> Vertical <input type="checkbox"/> Multi-axis: Vertical + _____ ° and – _____ °
<b>Union Location</b>	<input type="checkbox"/> Spindle <input type="checkbox"/> Motor Spindle <input type="checkbox"/> Indexing Table or Pallet <input type="checkbox"/> Other: _____
<b>Available Space</b>	Maximum overall length = _____ mm      Maximum diameter = _____ mm (Please attach drawings or photographs of the area where the union will be installed.)
<b>Mounting</b>	Bearing-supported: <input type="checkbox"/> Rotor-mounted <input type="checkbox"/> Bore-mounted Bearingless: <input type="checkbox"/> Outboard mounting <input type="checkbox"/> Inboard mounting <input type="checkbox"/> Around the shaft (shaft diameter = _____ mm) <input type="checkbox"/> Other: _____
<b>Rotor Style</b>	<input type="checkbox"/> Threaded (pitch and diameter = _____) <input type="checkbox"/> Flanged (diameter = _____) <input type="checkbox"/> Other: _____
<b>Media</b>	<input type="checkbox"/> Water-based coolant <input type="checkbox"/> Cutting oil <input type="checkbox"/> Hydraulic oil <input type="checkbox"/> Air-oil mist <input type="checkbox"/> Lubricated air <input type="checkbox"/> Dry air <input type="checkbox"/> Other: _____
<b>Operating Conditions</b>	<input type="checkbox"/> Maximum pressure _____ bar (when rotating) _____ bar (when stopped) <input type="checkbox"/> Maximum speed _____ rpm <input type="checkbox"/> Maximum flow _____ liters per minute <input type="checkbox"/> Maximum temperature _____ °C

**The better we understand your requirements,  
the faster and more accurately we can respond.**

**WARNING** DEUBLIN unions should not be used to convey flammable media (flash point ≤ 140°F or 60°C) as leakage may result in explosions or fires. DEUBLIN unions should be used in accordance with standard safety guidelines for the media, and in a well-ventilated area. The use of our product on hazardous or corrosive media is strictly forbidden.



Since its founding in 1945 as a small, family-owned business, Deublin consistently has adhered to a policy of designing and building the best products of their kind in the world. The result of this policy has been constant growth through the years, and for this we are grateful to our many loyal customers.

Today, Deublin is the world's largest manufacturer of rotating unions, with state-of-the-art factories, technical sales and service, and local stocking in 15 countries on four continents, as well as a worldwide distribution network operating from more than 60 countries. Our global organization and extensive catalog of field-tested products ensure a precise match between each customer's requirements and an engineered solution.

We cordially invite you to visit our modern manufacturing facilities in Waukegan, Illinois, USA; Mainz, Germany; Montevoglio, Italy; Dalian, China; and Sao Paulo, Brazil.



Global Headquarters in Waukegan, Illinois, U.S.A.



Mainz, Germany



Montevoglio, Italy



Dalian, China



Deublin products & services are available throughout the world.

[www.deublin.com](http://www.deublin.com)

## AMERICAS

### DEUBLIN USA

2050 Norman Drive  
Waukegan, IL 60085 U.S.A.  
Phone: +1 847 689-8600  
Fax: +1 847 689-8690  
e-mail: [cs@deublin.com](mailto:cs@deublin.com)

### DEUBLIN Brazil

Rua Fagundes de Oliveira, 538 - A11 –  
Piraporinha  
CEP: 09950-300 - Diadema - SP – Brazil  
Phone: +55 11-2455-3245  
Fax: +55 11-2455-2358  
e-mail: [deublinbrasil@deublinbrasil.com.br](mailto:deublinbrasil@deublinbrasil.com.br)

### DEUBLIN Mexico

Norte 79-A No. 77, Col. Claveria  
02080 Mexico, D.F.  
Phone: +52 55-5342-0362  
Fax: +52 55-5342-0157  
e-mail: [deublinmexicocs@deublin.com](mailto:deublinmexicocs@deublin.com)

## ASIA

### DEUBLIN China

No. 2, 7th Street, DD Port,  
Economic Development Zone, Dalian,  
Liaoning Province, 116620, P.R. China  
Phone: +86 411-87549678  
Fax: +86 411-87549679  
e-mail: [info@deublin.cn](mailto:info@deublin.cn)

Room15A07, Wangjiao Plaza  
No.175 East Yan'an Road, Huangpu District  
Shanghai, 200041, P.R. China  
Phone: +86 21-52980791  
Fax: +86 21-52980790  
e-mail: [service@deublin.cn](mailto:service@deublin.cn)

### DEUBLIN Asia Pacific

51 Goldhill Plaza, #17-02  
Singapore 308900  
Phone: +65 6259-9225  
Fax: +65 6259-9723  
e-mail: [deublin@singnet.com.sg](mailto:deublin@singnet.com.sg)

### DEUBLIN Japan

2-13-1, Minamihanayashiki  
Kawanishi City 666-0026, Japan  
Phone: +81 72-757-0099  
Fax: +81 72-757-0120  
e-mail: [customerservice@deublin.jp](mailto:customerservice@deublin.jp)

2-4-10-3F Ryogoku  
Sumida-Ku, Tokyo 130-0026, Japan  
Phone: +81 35-625-0777  
Fax: +81 35-625-0888  
e-mail: [customerservice@deublin.jp](mailto:customerservice@deublin.jp)

1-9-2-4F Mikawaanjo-cho  
Anjo City, Aichi 446-0056, Japan  
Phone: +81 566-7361  
Fax: +81 566-71-4360  
e-mail: [customerservice@deublin.jp](mailto:customerservice@deublin.jp)

### DEUBLIN Korea

Star Tower #1003, Sangdaewon-dong 223-25,  
Jungwon-gu, Seongnam-si, Gyeonggi-do,  
South Korea  
Phone: +82-31-8018-5777  
Fax: +82-31-8018-5780  
e-mail: [customerservice@deublin.kr](mailto:customerservice@deublin.kr)

## EUROPE

### DEUBLIN Germany

Florenz - Allee 1  
55129 Mainz, Germany  
Phone: +49 6131-4998-0  
Fax: +49 6131-4998-109  
e-mail: [info@deublin.de](mailto:info@deublin.de)

### DEUBLIN Italy

Via Guido Rossa, 9  
40053 Comune di Valsamoggia (BO), Italy  
Phone: +39 051-835611  
Fax: +39 051-832091  
e-mail: [info@deublin.it](mailto:info@deublin.it)

### DEUBLIN Austria

Mitterfeldgasse 3/18/R02  
1110 Vienna, Austria  
Phone: +43 1-8768450  
Fax: +43 1-876845030  
e-mail: [info@deublin.at](mailto:info@deublin.at)

### DEUBLIN France

61 bis, Avenue de l'Europe  
Z.A.C de la Malnoue  
77184 Emerainville, France  
Phone: +33 1-64616161  
Fax: +33 1-64616364  
e-mail: [service.client@deublin.fr](mailto:service.client@deublin.fr)

### DEUBLIN Poland

ul. Bierutowska 57-59  
51-317 Wroclaw, Poland  
Phone: +48 71-3528152  
Fax: +48 71-3276278  
e-mail: [info@deublin.pl](mailto:info@deublin.pl)

### DEUBLIN Russia

5-ya Sokolnoi gori, 18, bld. 2, office 1  
105275, Moscow, Russia  
Phone: +7 495 647-14-34  
Fax: +7 495 938-89-49  
e-mail: [info@deublinrussia.ru](mailto:info@deublinrussia.ru)

### DEUBLIN Spain

C/Lola Anglada, 20 local 1,  
08228 Terrassa, Spain  
Phone: +34 93-2211223  
Fax: +34 93-2212093  
e-mail: [deublin@deublin.es](mailto:deublin@deublin.es)

### DEUBLIN United Kingdom

6 Sopwith Park, Royce Close,  
West Portway  
Andover SP10 3TS, UK  
Phone: +44 1264-333355  
Fax: +44 1264-333304  
e-mail: [info@deublin.co.uk](mailto:info@deublin.co.uk)