

DEUBLIN

HOERBIGER Rotary Solutions



ROTATING UNIONS

water steam air hydraulic hot oil vacuum coolant custom applications

Selection Chart for DEUBLIN Rotating Unions

Size	Series	Max. Operating Data			Description	Passages	Pages
		PSI	Temp. °F	Speed RPM			
Water & Hot Oil up to 250°F *							6-21
3/8" - 2"	55	750	250	3,500	General Purpose	1 or 2	6 - 10
3/8" - 2"	57	150	200	3,500	Water Service	1 or 2	7 - 10
2 1/2"	755	200	250	750	General Purpose	1 or 2	11
3"	857	150	250	500	Water Service	1 or 2	12 - 13
3/8" - 1"	54	1,800	200	3,500	316 Stainless Steel	1	14
3/8"	927	4,000	200	2,000	Water Service High Pressure	1	15
1/2" - 3/4"	22	1,500	250	250	Water Service Car Wash	1	15
2" - 4"	6000	150	250	750	Water Service Cartridge Seal	1 or 2	16 - 19
5"	F127	150	250	750	Water Service	1 or 2	20
3/4" - 1 1/2"	2400	150	250	100	Water Service Continuous Casters	1 or 2	21
Steam & Hot Oil up to 450°F *							22-30
3/8" - 1/2"	N Steam	250	400	750	Single Bearing Spherical Seal	1 or 2	22
3/8" - 1/2"	N Hot Oil	100	450	750	Single Bearing Spherical Seal	1 or 2	22
3/4" - 2"	9000 Steam	150	365	400	Single Bearing Spherical Seal	1 or 2	23 - 25
1 1/2"	HPS Steam	250	400	400	Dual Bearing Spherical Seal	2	26
3/4" - 2"	H Steam	150	365	400	Dual Bearing Spherical Seal	1 or 2	27 - 30
2 1/2" - 5"	H Steam	150	365	180	Dual Bearing Spherical Seal	1 or 2	27 - 30
3/4" - 2"	H Hot Oil	100	450	400	Dual Bearing Spherical Seal	1 or 2	27 - 30
2 1/2" - 5"	H Hot Oil	100	450	350	Dual Bearing Spherical Seal	1 or 2	27 - 30
3/4" - 2"	Type C Hot Oil	100	450	400	Dual Bearing Spherical Seal	1 or 2	**
Air & Hydraulic							31-45
1/8" - 3/8"	1005, 1102, 1115	1,000	250	3,500	Standard Applications	1	31 - 32
1/2"	1205, 2200	1,000	250	3,500	Standard Applications	1	31 - 32
3/4" - 1 1/2"	250, 355, 452	1,000	250	3,500	Standard Applications	1	33
1/8" - 3/8"	1005, 1102, 1115	1,000	250	3,500	In-the-shaft Mounted	1	34
1/4" - 1/2"	AP	5,700	200	1,500	High Pressure High Speed	1	35
1/4" - 1 1/2"	D	6,400	120	20	High Pressure Low Speed or Swivel	1	36
3/8" X 2	1500	150	250	1,500	DEU-PLEX Air	2	37
1/4" X 2	2620	2,000	160	12,000	DEU-PLEX Air & Hyd Oil	2	38 - 39
1/2" X 2	1590	150	250	1,500	DEU-PLEX Air	2	40
1/2" X 2	1579	1,000	250	1,500	DEU-PLEX Hyd Oil	2	40
3/8" - 1/2" X 4	1379, 1479	3,600	175	250	Multi Media 4 Pass	4	41
1/4" - 1/2"	17,21	3,000	250	250	Low Speed Air & Hyd Oil	1	42
1/4" X 1/2"	2117	3,000	250	250	Low Speed Tandem Air & Hyd Oil	2	43
1/4"-1/2"-3/4" X 2	1690, 1790, 1890	3,000	250	250	DEU-PLEX Low Speed	2	44 - 45
1/4" X 3/4" X 3	1890	3,000	250	250	Triple Passage	3	45
Coolant (Wider range of products featured in Coolant Union Catalog)							46-51
3/8"	1117	2,000	160	20,000	Bearingless	1	46
3/8"	1129	2,000	160	20,000	Bearingless ("Pop-Off") High Speed	1	47
3/16"	1101	1,500	160	15,000	Standard Applications High Speed	1	48
3/8"	1116	1,000	160	12,000	Standard Applications	1	49
1/4" - 3/8"	1109	1,500	160	20,000	Dry-run ("Pop-Off") High Speed	1	50
3/8"	902	1,000	160	10,000	Dry-run ("Pop-Off")	1	51
Unions for Special Applications *							52-53
1/8" - 1"	1005, 468, 981	750	250	3,500	Water, Oil Rig, Clutch & Brake	1 to 3	52
1/4" - 3/8"	1102, 1115, 882	150	250	3,500	Central Tire Inflation	1 or 2	52
Custom	7000 / 7100	3,000	250	5,000	Around The Shaft		53

* **Attention!** For applications exceeding indicated limits, contact DEUBLIN. Indicate media, size, speed (RPM), pressure, temperature and connection specifications.

** Download PDF from website

- Subject to technical and dimensional changes without notice.

DEUBLIN KEEPS THE WORLD ROTATING



Since 1945, Deublin has grown from a small garage shop to the world's largest manufacturer of rotating unions. Today, Deublin's international headquarters is located in Waukegan, Illinois, with manufacturing facilities, sales offices and warehouses located in 17 countries on four continents.

Our worldwide distribution network allows end users all over the world to specify Deublin unions when purchasing equipment made in another country. We're manufacturers ourselves, so we understand the importance of fast response time to keep your manufacturing process rolling. Wherever you're located, Deublin has a stocking distributor nearby to meet your requirements—quickly.



UNIQUE REQUIREMENTS DEMAND CUSTOM UNIONS

Rotating unions must accommodate a broad range of materials, viscosities, temperatures, pressures and speeds. That's why the Deublin product line offers over 500 standard unions, over 3,000 separate models.

Even this extensive line cannot meet all the specialized needs required by our customers. That's why we manufacture an ever-growing line of custom unions to meet individual manufacturers' particular requirements. In many instances, we can adapt or convert an existing union and offer a cost-effective solution to meet your exact specifications.



A ROTATING UNION FOR EVERY APPLICATION



Rotating unions are used in many manufacturing processes to cool, heat or transfer fluid (pneumatic or hydraulic) power. Typical rotating unions feature deep groove ball bearings to support the rotating component against the stationary component, and balanced, precision-engineered mechanical seals to seal the media flow. Deublin rotating unions vary for each application, depending on design, bearing type, construction and material required.

In 1989, the Deublin product line was expanded to include steam joints and siphon systems for paper machine dryer cans.

Here are just some of the industries that rely on Deublin for their unique rotating union needs:

- ALUMINUM
- AUTOMOTIVE
- CAN MAKING
- CAR WASH EQUIPMENT
- CHEMICAL/PETROCHEMICAL/REFINERY
- CONSTRUCTION EQUIPMENT
- DISTILLERIES/BREWERIES
- FARM EQUIPMENT
- FLOOR & WALL COVERINGS
- FOOD PROCESSING MACHINERY
- GLASS MANUFACTURING
- INSULATION
- LAUNDRY EQUIPMENT
- LUMBER & WOODWORKING
- MACHINE TOOL
- MARINE
- MINING
- PAPER
 - CONVERTING PLANTS
 - CORRUGATING
 - PULP & PAPERBOARD
 - ROOFING
- PETROLEUM
- PLASTICS
- PRINTING
 - BUSINESS FORMS
 - FLEXOGRAPHIC
 - WEB OFFSET
- RUBBER
- STEEL
- TEXTILE
- TIRES
- TRUCKING

DEUBLIN'S state-of-the-art manufacturing facilities are strategically located worldwide, and feature the latest CNC technologies including multi-axis/multi-function, robotic interfaces, single point threading and cylindrical grinding.

These advanced machining techniques and proprietary processes allow Deublin to achieve the most precise tolerances in the industry, and ensure superior union performance and service life.

WE TREAT PRECISION AS AN EXACT SCIENCE

PRECISION

A rotating union must be capable of containing high pressures while rotating at very high speeds. Smooth, easy rotation can only be achieved by exactly mating the seal faces to minimize friction.

Precision and tight tolerances are critical in the micro lapping of seal faces. All Deublin seals are micro lapped to an optical flatness within 2 light bands or 0.000023" utilizing proprietary lapping machinery and compounds. This level of precision is essential for dependable leak-proof operation.

Housings are machined on multi-axis twin-spindle lathes to obtain the necessary part-to-part precision. Rotors and other parts are turned on automatic bar machines to ensure true-running rotating unions without any wobble. This assures extended service life.



BALANCED MECHANICAL SEAL

The greater the pressure on a rotating seal face, the greater the friction, torque and wear on the union. That's why Deublin rotating unions feature "balanced mechanical seals." With this technology, the thrust load or seal face contact pressure is kept to a minimum regardless of media pressure. This reduces wear, resulting in longer seal life. The spring-loaded seal is keyed so that it cannot rotate or creep, which can cause premature failure in secondary seals, resulting in a leaking union.

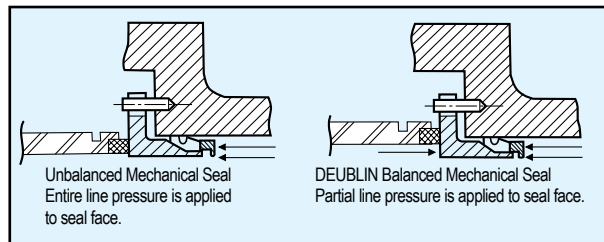

EXTENDED LIFE SEALING

Responding to ever-increasing speeds and pressures, Deublin pioneered Extended Life Sealing (E.L.S.). E.L.S. rotating unions offer outstanding performance under the toughest conditions, and can extend service life two to four times, depending on the severity of the application. E.L.S. unions use advanced materials such as tungsten carbide and silicon carbide to provide the best possible seal solution for the application.

Where reliability is of prime importance, E.L.S. should be specified to protect against contaminants and resist wear caused by rust, scale, chips and other harmful abrasives.



PROFESSIONAL SERVICE AROUND THE WORLD

At Deublin, our service is as reliable as our products. Given the importance of rotating unions to your equipment's performance, our products have to be reliable. To provide you local and emergency service, we have a worldwide service network consisting of wholly-owned subsidiaries and authorized distribution network.

Whether you need a spare part, a new product, technical advice, or help with an ongoing design project, our experienced customer service representatives and engineers are always available to provide immediate assistance.

For all your rotating union requirements—no matter how unique or complex—you can rely on Deublin.

NUMBER SYSTEM

DEUBLIN ordering numbers for standard rotating unions consist of 2, 3 or 4 number groups. Each group describes a particular characteristic feature such as application, seal combination or rotor connection (refer to ordering example).

Rebuilding and repair kit numbers differ from their respective rotating union numbers by the insertion of a letter (B or C). The letter B stands for a rebuilding kit, and the letter C for a repair kit (refer to ordering example).

ORDERING EXAMPLE:

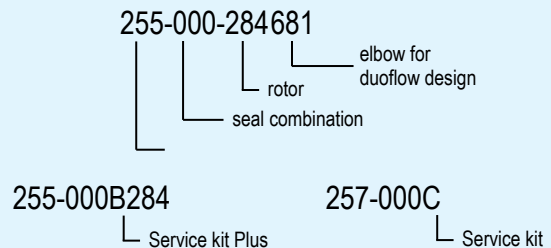

DEUBLIN

General Purpose 55 Series Unions

- Monoflow and duoflow design
- Self-supported rotating union
- Radial housing connection
- Balanced mechanical seal
- 3 vent holes
- Forged brass housing
- Stainless steel rotor
- Special options:
threaded vent holes,
low torque design
- Lubrication Guide page 55



Operating Data

Maximum Water Pressure	Model 55-555	750 PSI	50 bar
Maximum Water Pressure	Model 655	600 PSI	41 bar
Maximum Saturated Steam Pressure (Intermittent)		15 PSI	1 bar
Maximum Hot Oil Pressure		100 PSI	6.6 bar
Maximum Speed NPT Threads	Model 55-555	1,500 RPM	1,500/min
	Model 655	750 RPM	750/min
Maximum Speed Straight Threads			
	Model 55-255	3,500 RPM	3,500/min
	Model 355	3,000 RPM	3,000/min
	Model 525-555	2,500 RPM	2,500/min
	Model 655	750 RPM	750/min

Maximum Temperature

250°F

>250°F consult **DEUBLIN**

Seal Combinations

- Carbon Graphite/Bronze for water - Standard
- Carbon Graphite/Ceramic for hot oil, hot water and saturated steam - Optional
- Multi-purpose applications

Seal Combination - E.L.S.

- Tungsten Carbide/Ceramic for severe conditions (poor water quality), max. temperature 200°F

Torque Ratings 55 Series

Size	ft.lbs	Nm
55	¼	0.34
155	⅜	0.50
255	½	0.68
355	1½	1.80
525	1½	1.80
555	2½	3.40
655	3	4.07

Illustration shows duoflow with fixed supply pipe. Monoflow units have pipe plugs instead of an elbow.

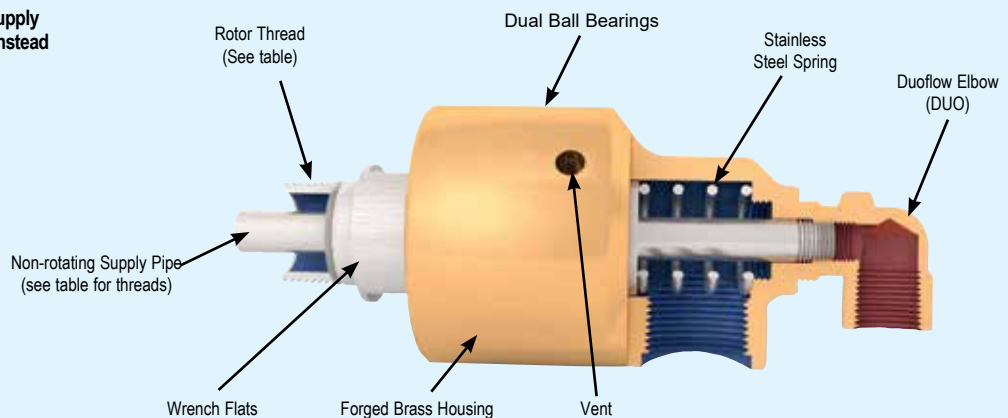

DEUBLIN

57 Series with Silicon Carbide Seals, for Water Service



- Monoflow and duoflow design
- Self-supported rotating union
- Radial housing connection
- Balanced mechanical seal
- Keyed rotor seal
- Easy and quick replacement of sealing components (rotor seal, floating seal)
- Ball bearings lubricated for life
- For poor water quality (E.L.S.)
- 3 vent holes
- Forged brass housing
- Stainless steel rotor
- Special options:
threaded vent holes

Operating Data

Maximum Water Pressure		150 PSI	10 bar
Maximum Speed NPT Threads	Model 57-557	1,500 RPM	1,500/min
	Model 657	750 RPM	750/min
Maximum Speed Straight Threads			
	Model 57-257	3,500 RPM	3,500/min
	Model 357	3,000 RPM	3,000/min
	Model 527-557	2,500 RPM	2,500/min
	Model 657	750 RPM	750/min

Maximum Water Temperature 200°F >200°F consult **DEUBLIN**

Seal Combination

- Carbon Graphite/Silicon Carbide - Standard

Seal Combination - E.L.S.

- Silicon Carbide/Silicon Carbide for severe conditions (poor water quality)

Torque Ratings 57 Series

Size	ft.lbs	Nm
57	¼	0.25
157	½	0.50
257	¾	1.00
357	1½	2.00
527	1½	2.20
557	2¼	2.90
657	3½	4.50

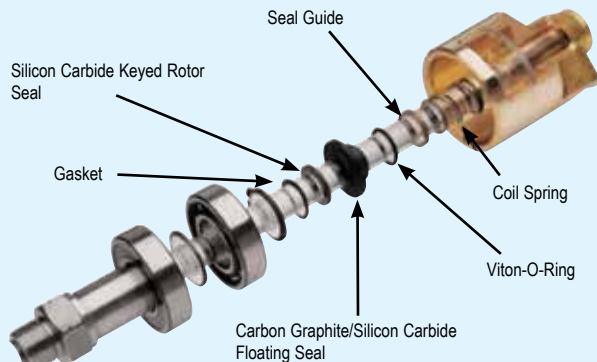

Union Repair

The 57 Series is designed for quick, easy replacement of both Floating Seal and the Rotor Seal.

The "57's" seal is seated in a keyed counter bore at the rotor's end. The worn seal simply lifts out and the new one drops right in. Since the entire rotor does not need to be replaced or relapped, the repair is fast, easy and on the spot. As you only replace the seals, the repair cost is very economical.

For Ordering Number of Repair Kit see page 5.

55 & 57 Series Monoflow Union Specifications

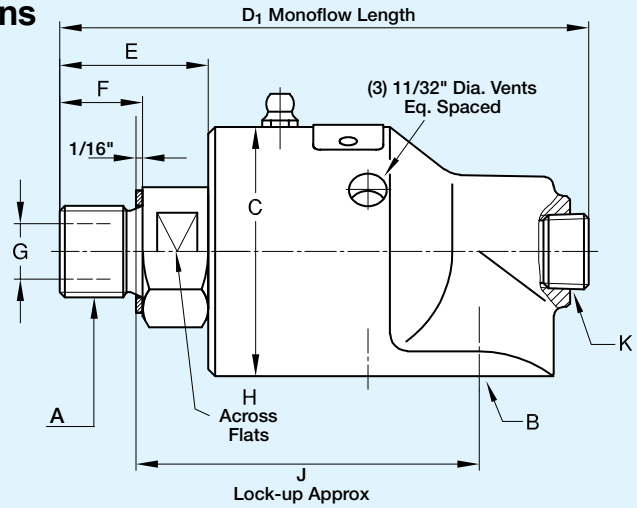

Chart Instructions

Select Union Size and Rotor Thread. Follow this line to opposite page to find Duoflow Elbow Specifications. Add Duoflow Elbow Suffix to the end of the Ordering Number.

† Recessed O-Ring in Rotor End in Place of Copper Gasket

B Port NPT	Ordering Number				A* Rotor Thread	C	D ₁	D ₂	E	F	G	H**	J
	55 Series All Purpose	55 Series E.L.S.	57 Series Water Service	57 Series E.L.S.									
3/8"	55-000-001	55-147-151	57-000-001	57-050-001	3/8" NPT RH	1 3/4"	3 15/16"	4 13/16"	1"	5/8"	3/8"	22	2 11/16"
	55-000-002	55-147-152	57-000-002	57-050-002	3/8" NPT LH	1 3/4"	3 15/16"	4 13/16"	1"	5/8"	3/8"	22	2 11/16"
	55-000-003	55-147-149	57-000-003	57-050-003	5/8"-18 UNF RH	1 3/4"	3 15/16"	4 13/16"	1"	5/8"	3/8"	22	2 1/2"
	55-000-004	55-147-150	57-000-004	57-050-004	5/8"-18 UNF LH	1 3/4"	3 15/16"	4 13/16"	1"	5/8"	3/8"	22	2 1/2"
	55-000-094	55-147-192	57-000-094	57-050-094	G 3/8" (BSP) RH	44.5	102	123	26	16	9.5	22	63
1/2"	55-000-095	55-147-193	57-000-095	57-050-095	G 3/8" (BSP) LH	44.5	102	123	26	16	9.5	22	63
	155-000-001	155-208-113	157-000-001	157-050-001	1/2" NPT RH	2 1/4"	4 13/16"	5 7/8"	1 1/16"	7/8"	1/2"	30	3 1/2"
	155-000-002	155-208-114	157-000-002	157-050-002	1/2" NPT LH	2 1/4"	4 13/16"	5 7/8"	1 1/16"	7/8"	1/2"	30	3 1/2"
	155-000-021	155-208-185	157-000-021	157-050-021	3/4"-16 UNF RH	2 1/4"	4 11/16"	5 3/4"	1 5/16"	3/4"	1/2"	30	3 1/16"
	155-000-022	155-208-229	157-000-022	157-050-022	3/4"-16 UNF LH	2 1/4"	4 11/16"	5 3/4"	1 5/16"	3/4"	1/2"	30	3 1/16"
	155-000-151	155-208-252	157-000-151	157-050-151	G 1/2" (BSP) RH	57.2	120	148	34	19	12.7	30	78
3/4"	155-000-152	155-208-253	157-000-152	157-050-152	G 1/2" (BSP) LH	57.2	120	148	34	19	12.7	30	78
	255-000-020	255-052-255	257-000-020	257-050-020	3/4" NPT RH	2 7/8"	5 5/16"	6 3/4"	1 1/16"	7/8"	1 1/16"	32	4 1/16"
	255-000-021	255-052-256	257-000-021	257-050-021	3/4" NPT LH	2 7/8"	5 5/16"	6 3/4"	1 1/16"	7/8"	1 1/16"	32	4 1/16"
	255-000-003	255-052-258	257-000-135†	257-050-135†	1"-14 UNS RH	2 7/8"	5 7/16"	6 5/8"	1 5/16"	3/4"	2 1/32"	32	3 11/16"
	255-000-027	255-052-257	257-000-136†	257-050-136†	1"-14 UNS LH	2 7/8"	5 7/16"	6 5/8"	1 5/16"	3/4"	2 1/32"	32	3 11/16"
	255-000-284	255-052-445	257-000-284	257-050-284	G 3/4" (BSP) RH	73	138	168	34	19	17.5	36	94
1"	255-000-285	255-052-446	257-000-285	257-050-285	G 3/4" (BSP) LH	73	138	168	34	19	17.5	36	94
	355-000-002	355-064-186	357-000-002	357-050-002	1" NPT RH	3 3/4"	6 13/16"	8 5/16"	1 15/16"	1 1/8"	1"	36	4 11/16"
	355-000-003	355-064-187	357-000-003	357-050-003	1" NPT LH	3 3/4"	6 13/16"	8 5/16"	1 15/16"	1 1/8"	1"	36	4 11/16"
	355-000-019	355-064-328	357-000-019	357-050-019	1 1/2"-12 UNF RH	3 3/4"	6 13/16"	8 5/16"	1 15/16"	1 1/8"	1"	36	4 1/4"
	355-000-074	355-064-329	357-000-074	357-050-074	1 1/2"-12 UNF LH	3 3/4"	6 13/16"	8 5/16"	1 15/16"	1 1/8"	1"	36	4 1/4"
	355-000-222	355-064-378	357-000-222	357-050-222	G 1" (BSP) RH	83	166	204	42	21.5	22.2	36	108
1 1/4"	355-000-223	355-064-379	357-000-223	357-050-223	G 1" (BSP) LH	83	166	204	42	21.5	22.2	36	108
	525-000-001	525-097-043	527-000-001	527-050-001	1 1/4" NPT RH	3 3/16"	7 7/16"	9 3/8"	2 3/16"	1 1/8"	1 1/4"	46	5 1/4"
	525-000-002	525-097-044	527-000-002	527-050-002	1 1/4" NPT LH	3 3/16"	7 7/16"	9 3/8"	2 3/16"	1 1/8"	1 1/4"	46	5 1/4"
	525-000-026	525-097-095	527-000-026	527-050-026	1 3/4"-12 UN RH	3 3/16"	7 7/16"	9 3/8"	2 3/16"	1 1/8"	1 1/4"	46	4 11/16"
	525-000-027	525-097-096	527-000-027	527-050-027	1 3/4"-12 UN LH	3 3/16"	7 7/16"	9 3/8"	2 3/16"	1 1/8"	1 1/4"	46	4 11/16"
	525-000-054	525-097-122	527-000-054	527-050-054	G 1 1/4" (BSP) RH	90.5	191	234	54	27	30.2	46	119
1 1/2"	525-000-055	525-097-123	527-000-055	527-050-055	G 1 1/4" (BSP) LH	90.5	191	234	54	27	30.2	46	119
	555-000-001	555-033-154	557-000-001	557-050-001	1 1/2" NPT RH	4 1/4"	8 1/2"	10 5/16"	2 7/16"	1 3/16"	1 1/2"	55	6"
	555-000-002	555-033-160	557-000-002	557-050-002	1 1/2" NPT LH	4 1/4"	8 1/2"	10 5/16"	2 7/16"	1 3/16"	1 1/2"	55	6"
	555-000-395	555-033-399	557-000-395	557-050-395	2"-12 UN RH	4 1/4"	8 7/8"	10 11/16"	2 13/16"	1 1/8"	1 1/2"	55	5 13/16"
	555-000-396	555-033-382	557-000-396	557-050-396	2"-12 UN LH	4 1/4"	8 7/8"	10 11/16"	2 13/16"	1 1/8"	1 1/2"	55	5 13/16"
	555-000-198	555-033-288	557-000-198	557-050-198	G 1 1/2" (BSP) RH	108	225	268	71	29	35	55	147
2"	555-000-199	555-033-289	557-000-199	557-050-199	G 1 1/2" (BSP) LH	108	225	268	71	29	35	55	147
	655-500-116	655-502-116	657-000-116	657-050-116	2" NPT RH	4 5/8"	10 1/16"	11 3/4"	3"	1 1/2"	1 7/8"	60	7"
	655-500-117	655-502-117	657-000-117	657-050-117	2" NPT LH	4 5/8"	10 1/16"	11 3/4"	3"	1 1/2"	1 7/8"	60	7"
	655-500-124	655-502-124	657-000-124	657-050-124	G 2" (BSP) RH	117	246	289	65	28.6	47	60	164
655-500-125	655-502-125	657-000-125	657-050-125	G 2" (BSP) LH	117	246	289	65	28.6	47	60	164	

*Metric threads and other thread sizes are available. Contact factory for further information. For 2", 2 1/2", 3", 4" and 5" capacity unions refer to pages 11-13 and 16-20. **Metric

55 & 57 Series Duoflow Union Specifications

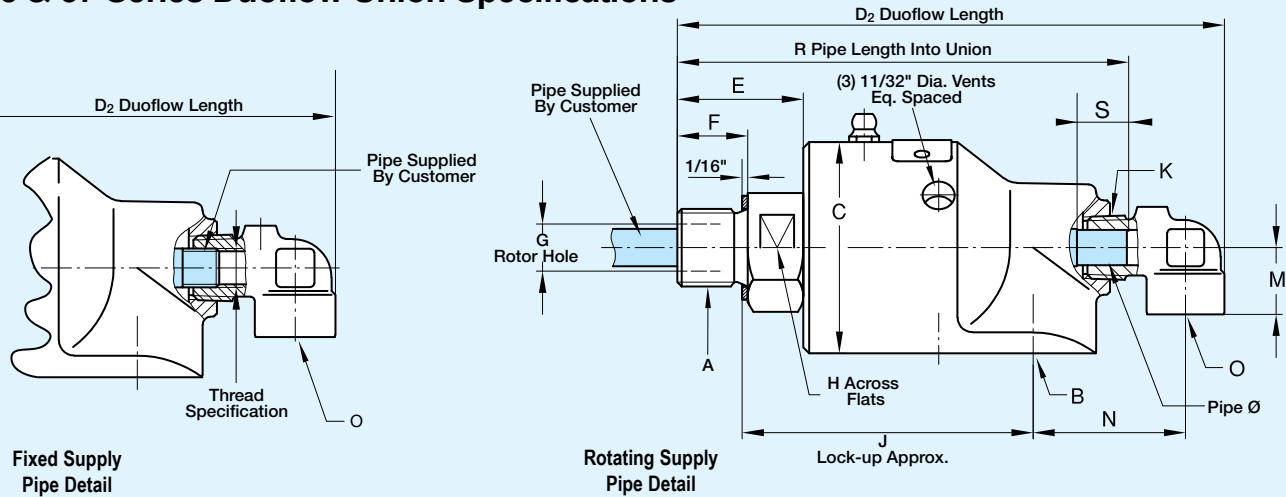

For Description See Page 10

Fixed Supply Pipe			Fixed Supply Tube			Rotating Supply Pipe									
Elbow Suffix	Thread	R	Elbow Suffix	Tube OD	R	Elbow Suffix	Pipe Size	Pipe Dia.	S	R	K NPT	M	N	O NPT	Shpg. Wt.
—	—	—	-030	.250"	4 ³ / ₁₆ "	—	—	—	—	—	1/4"	1 ¹ / ₁₆ "	1 ³ / ₁₆ "	1/4"	2#
—	—	—	-030	.250"	4 ³ / ₁₆ "	—	—	—	—	—	1/4"	1 ¹ / ₁₆ "	1 ³ / ₁₆ "	1/4"	2#
-120	M6X1	98.5	—	—	—	—	—	—	—	—	1/4"	18	35	1/4"	0.9 Kg
-012	1/8" NPT	4 ³ / ₄ "	-061	.375"	5 ⁵ / ₁₆ "	—	—	—	—	—	3/8"	1 ¹ / ₁₆ "	1 ¹ / ₂ "	3/8"	3#
-012	1/8" NPT	4 ³ / ₄ "	-061	.375"	5 ⁵ / ₁₆ "	-061	1/8"	.371" .370"	1 ¹ / ₁₆ "	5"	3/8"	1 ¹ / ₁₆ "	1 ¹ / ₂ "	3/8"	3#
-199	G ¹ / ₂ " (BSP)	117	—	—	—	-471	—	9.93 9.90	30	127	3/8"	18	38	3/8"	1.4 Kg
-043	1/4" NPT	5 ¹ / ₄ "	-075	.500"	5 ¹³ / ₁₆ "	—	—	—	—	—	1/2"	1"	1 ³ / ₄ "	1/2"	5#
-044	1/8" NPT	5 ¹ / ₄ "	-026	.437"		—	—	—	—	—	—	1/2"	1"	1 ³ / ₄ "	1/2"
-043	1/4" NPT	5 ⁵ / ₁₆ "	-075	.500"	5 ¹³ / ₁₆ "	-075	1/4"	.496" .495"	1 ¹ / ₄ "	5 ¹¹ / ₁₆ "	1/2"	1"	1 ³ / ₄ "	1/2"	5#
-044	1/8" NPT	5"	-026	.437"		-075	1/4"	.496" .495"	1 ¹ / ₄ "	5 ¹¹ / ₁₆ "	1/2"	1"	1 ³ / ₄ "	1/2"	5#
-368	G ¹ / ₄ " (BSP)	136.5	—	—	—	-681	—	12.95 12.90	31	146.5	1/2"	26	45	1/2"	2.3 Kg
-367	G ³ / ₈ " (BSP)	132.5	—	—	—	—	—	—	—	—	—	—	—	—	—
-083	3/8" NPT	7 ¹ / ₁₆ "	-163	.625"	7 ⁷ / ₈ "	—	—	—	—	—	3/4"	1 ¹ / ₁₆ "	2 ⁵ / ₁₆ "	1/2"	8#
-084	1/2" NPT	7"				—	—	—	—	—	—	—	3/4"	1 ¹ / ₁₆ "	2 ⁵ / ₁₆ "
-083	3/8" NPT	7 ¹ / ₁₆ "	-163	.625"	7 ⁷ / ₈ "	-163	3/8"	.621" .619"	1 ¹ / ₄ "	7"	3/4"	1 ¹ / ₁₆ "	2 ⁵ / ₁₆ "	1/2"	8#
-084	1/4" NPT	7"				-163	3/8"	.621" .619"	1 ¹ / ₄ "	7"	3/4"	1 ¹ / ₁₆ "	2 ⁵ / ₁₆ "	1/2"	8#
-255	G ³ / ₈ " (BSP)	162	—	—	—	-347	—	15.95 15.90	31	175	3/4"	27	59	1/2"	3.6 Kg
-007	1/2" NPT	8 ³ / ₈ "	-104	.750"	8 ³ / ₄ "	—	—	—	—	—	1"	1 ³ / ₈ "	2 ¹³ / ₁₆ "	3/4"	10#
-007	1/2" NPT	8 ³ / ₈ "	-104	.750"	8 ³ / ₄ "	-104	1/2"	.745" .743"	1 ¹ / ₂ "	8 ³ / ₁₆ "	1"	1 ³ / ₈ "	2 ¹³ / ₁₆ "	3/4"	10#
-079	G ¹ / ₂ " (BSP)	185.5	—	—	—	-237	—	21.94 21.89	38	201.5	1"	35	72	3/4"	4.5 Kg
-013	3/4" NPT	8 ¹³ / ₁₆ "	-263	1.000"	9 ⁹ / ₁₆ "	—	—	—	—	—	1 ¹ / ₄ "	1 ¹ / ₂ "	3 ¹ / ₁₆ "	3/4"	16#
-036	1/2" NPT	8 ³ / ₄ "				—	—	—	—	—	—	—	—	1 ¹ / ₄ "	1 ¹ / ₂ "
-013	3/4" NPT	9 ¹ / ₁₆ "	-263	1.000"	9 ¹ / ₂ "	-144	3/4"	1.000" .998"	1 ³ / ₄ "	9 ⁵ / ₁₆ "	1 ¹ / ₄ "	1 ¹ / ₂ "	3 ¹ / ₁₆ "	3/4"	16#
-036	1/2" NPT	9 ¹ / ₁₆ "				-144	3/4"	1.000" .998"	1 ³ / ₄ "	9 ⁵ / ₁₆ "	1 ¹ / ₄ "	1 ¹ / ₂ "	3 ¹ / ₁₆ "	3/4"	16#
-221	G ³ / ₄ " (BSP)	222	—	—	—	-468	—	25.91 25.81	44	244	1 ¹ / ₄ "	38	78	3/4"	7.2 Kg
-013	3/4" NPT	10 ¹ / ₄ "	-263	1.000"	10 ³ / ₈ "	—	—	—	—	—	1 ¹ / ₄ "	1 ¹ / ₂ "	3 ¹ / ₁₆ "	3/4"	17#
-183	1" NPT	10 ³ / ₈ "				-263	1.000"	10 ³ / ₈ "	—	—	—	—	—	1 ¹ / ₄ "	
-221	G ³ / ₄ " (BSP)	243	—	—	—	-468	—	25.91 25.81	44	250	1 ¹ / ₄ "	38	78	3/4"	7.7 Kg

Duoflow Supply Pipe Installations

Deublin water service unions can be adapted for Duoflow applications where a single media is circulated through and around the supply pipe. Duoflow elbows are available in 3 styles to accept a variety of different supply systems. The guidelines shown below should be carefully considered. A poorly designed supply system can contribute to premature union failure.

Where long pipes or high speeds are required, an adapter should be used to avoid transmitting stresses from heavy pipes, cascading water or vibrations to the union. A typical adapter is illustrated.

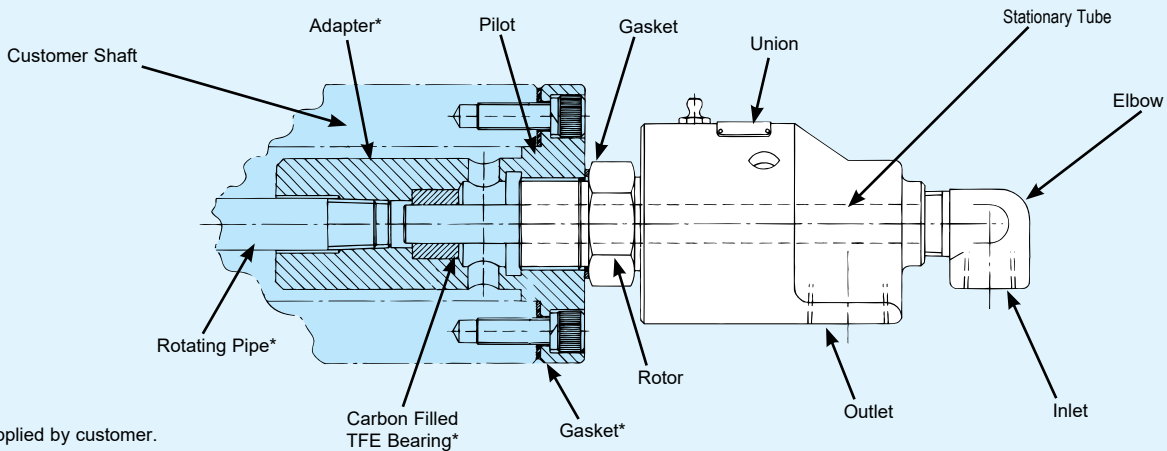

*Supplied by customer.

Threaded Pipe

The largest threaded supply pipe achieves the maximum flow rates available for a particular size union. Stresses at the pipe thread can cause breakage allowing the pipe to fall into the roll. For this reason pipe lengths longer than 4 union lengths ($4 \times D1$) and rotational speeds above 1000 RPM should be avoided.

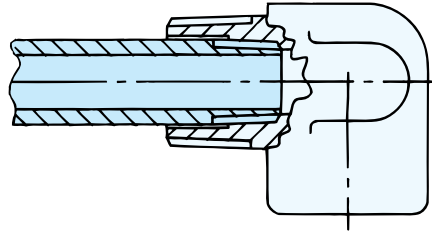

Fixed Tube

Thin wall stainless steel tube silver soldered into the Duoflow elbow produces the strongest, lightest weight assembly. The thinner wall sections allow greater flow rates than the threaded pipe. Maximum flow rates are obtained with the largest tube available for a given size union. Tube length is usually limited to 6 union lengths ($6 \times D1$). Speeds to 3500 RPM are possible.

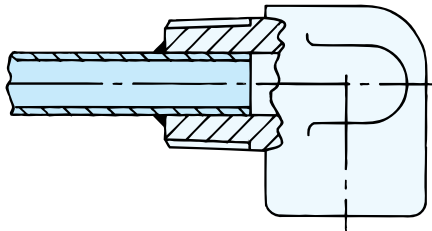

Rotating Pipe

Rotating pipes are fastened internally to rotate with the roll. The Duoflow elbow helps to support the pipe and restrict crosstalk between passages. The pipe must be straight and concentric to the center line to avoid excessive loading of the union. The union must also have a rotor with a straight thread (Example 1"-14" UNS) rather than a tapered pipe thread to assure concentricity. Rotational speeds above 1000 RPM should be avoided.

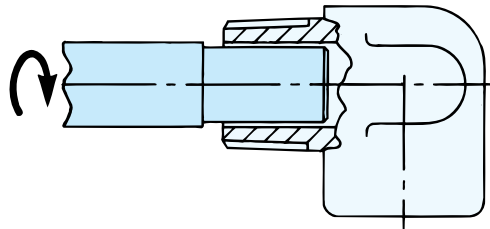



DEUBLIN

2 1/2" Field Repairable All Purpose Unions

- Monoflow and duoflow design
- Self-supported rotating union
- Radial housing connection
- Balanced mechanical seal
- 3 vent slots
- Cast iron housing - standard
Cast iron housing nickel-plated - optional
- Steel rotor
- Lubrication Guide page 55

Operating Data

Maximum Water Pressure	200 PSI	14 bar
Maximum Saturated Steam Pressure (Intermittent)	15 PSI	1 bar
Maximum Speed	750 RPM	750/min
Torque at 120 PSI/8.2 bar	4 ft.lbs.	5.4 Nm
Maximum Temperature	250°F	>250°F consult DEUBLIN

Seal Combination

- Carbon Graphite/Tungsten Carbide - Standard

Seal Combination - E.L.S.

- Tungsten Carbide/Ceramic for severe conditions (poor water quality), max. temperature 200°F

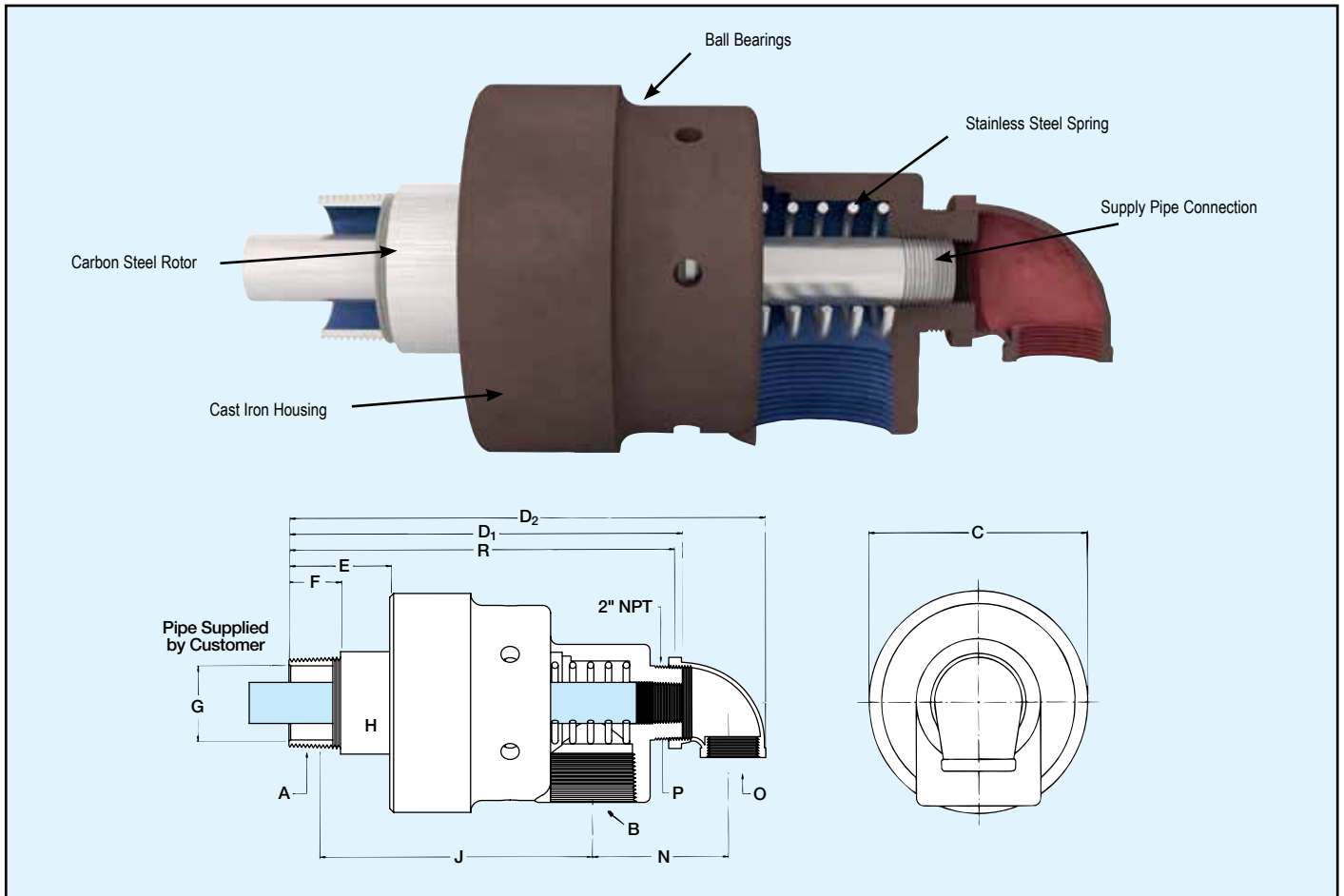

B Port NPT	Ordering Number*		A Rotor Thread	C Dia.	D ₁	D ₂	E	F	G Rotor Hole	H Dia.	J Lock- up	N	O NPT	P NPT	R	Shpg. Wt.
	All Purpose	E.L.S.														
2 1/2"	755-700-413-117	755-701-413-117	2 1/2" NPT RH	7"	13 1/2"	15"	3/4"	1 7/8"	2 3/8"	3 3/2"	8 5/8"	4 1/4"	1 1/4"	1"	12 1/8"	44#
	755-700-415-117	755-701-415-117	2 1/2" NPT LH													
2 1/2"	755-700-330-117	755-701-330-117	G2 1/2" (BSP) RH	178	343	381	82.5	38.1	60.3	83.3	207	108	1 1/4"	1"	308	20 Kg
	755-700-411-117	755-701-411-117	G2 1/2" (BSP) LH													
2 1/2"	755-702-413-139	755-703-413-139	2 1/2" NPT RH	7"	13 1/2"	15 1/4"	3/4"	1 7/8"	2 3/8"	3 3/2"	8 5/8"	4 3/8"	1 1/2"	** 1 1/2"	12 1/8"	44#
	755-702-415-139	755-703-415-139	2 1/2" NPT LH													

* Monoflow unions can be specified by omitting the -117 or -139 suffix. Flange rotor available upon request. Duoflow rotating pipe models available upon request.

** For recirculating water service (equal in and out flow) use 1 1/2" supply pipe.

DEUBLIN

3" Union for Rubber and Plastic Application

- Monoflow and duoflow design
- Self-supported rotating union
- Radial housing connection
- Balanced mechanical seal
- Seal combination:
Carbon Graphite/Tungsten Carbide
- Full-media flow
- Easy and quick replacement of sealing components (rotor seal, floating seal)
- Vented housing
- Cast iron housing - standard
- Steel rotor
- Lubrication Guide page 55



Operating Data

Maximum Water Pressure	150 PSI	10 bar
Maximum Saturated Steam Pressure (Intermittent)	15 PSI	1 bar
Maximum Speed	500 RPM	500/min
Torque @ 150 PSI/10bar	6 ft.lbs	8.2 Nm
Maximum Water Temperature	250°F	>250°F consult DEUBLIN

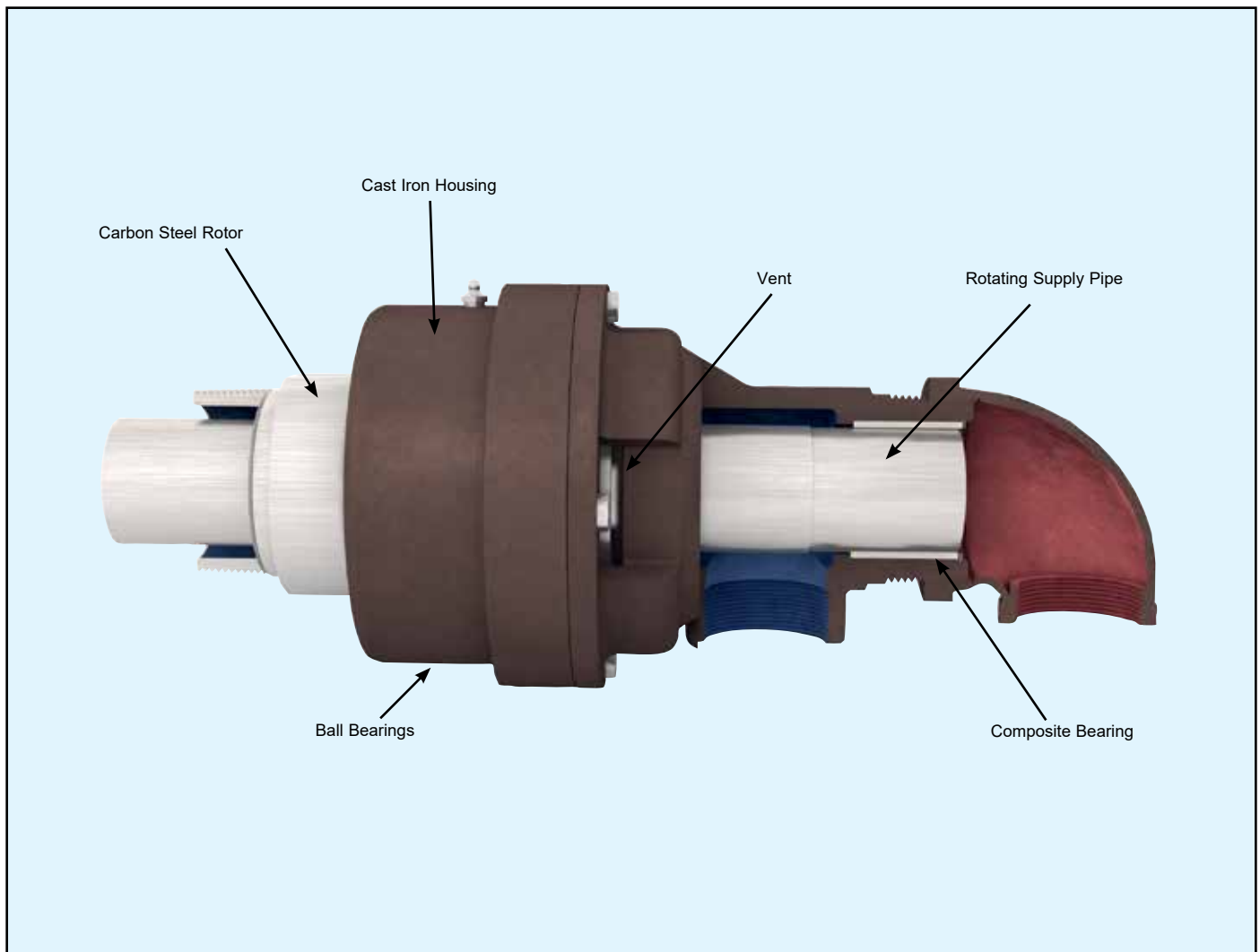

857 Series Specifications

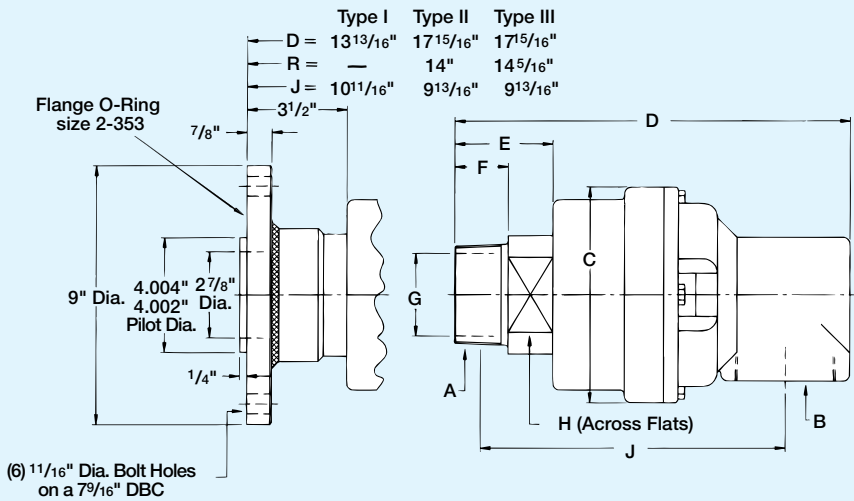

857-132 Flanged Rotor Detail

Type I Monoflow

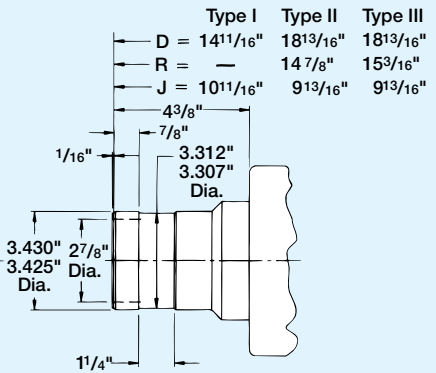

857-128 Quick Connect Rotor Detail

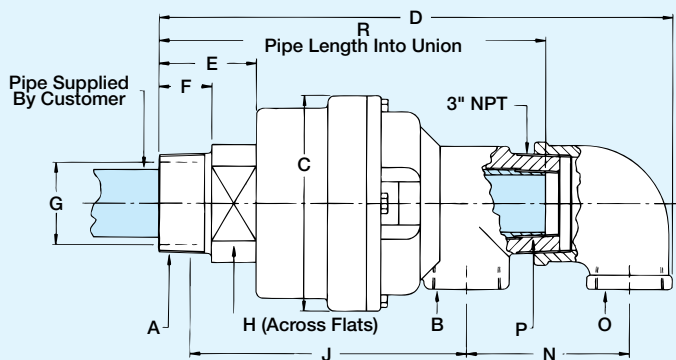

Type II Duoflow Fixed Pipe

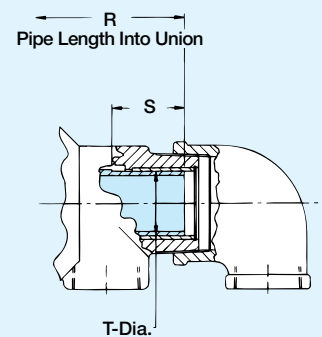

Type III Duoflow Rotating Pipe

B Port NPT	Ordering Number	A Rotor Thread	C Dia.	D	E	F	G	H*	J	N	O NPT	P NPT	R	S	T	Shpg. Wt.
Type I 3"	857-000-101	3" NPT RH	7 1/2"	13 3/4"	3 3/8"	1 1/8"	2 7/8"	100	10 9/16"	-	-	-	-	-	-	50#
	857-000-102	3" NPT LH														
	857-000-118	G3" (BSP) RH	190	344	83	44	73	100	244	-	-	-	-	-	-	23 Kg
	857-000-119	G3" (BSP) LH														
Type II 2"	857-001-101	3" NPT RH	7 1/2"	17 7/8"	3 3/8"	1 7/8"	2 7/8"	100	9 3/4"	5 1/16"	2"	2"	13 5/16"	-	-	55#
	857-001-102	3" NPT LH														
	857-001-118	G3" (BSP) RH	190	451	83	44	73	100	228	144	2"	2"	351	-	-	25 Kg
	857-001-119	G3" (BSP) LH														
Type III 2"	857-002-101	3" NPT RH	7 1/2"	17 7/8"	3 3/8"	1 7/8"	2 7/8"	100	9 3/4"	5 1/16"	2"	-	14 1/4"	2 3/4"	2.308" 2.302"	55#
	857-002-102	3" NPT LH														
	857-002-118	G3" (BSP) RH	190	451	83	44	73	100	228	144	2"	-	355	70	58.62 58.47	25 Kg
	857-002-119	G3" (BSP) LH														

*Metric

DEUBLIN

Stainless Steel Unions

- Monoflow and duoflow (available) design
- Self-supported rotating union
- Radial or axial (available) housing connection
- Wetted parts made of 316 stainless steel
- Suitable for the food, chemical & pharmaceutical industries
- Full-media flow

Seal Combination

- Carbon Graphite/Ceramic - Standard

Seal Combination - E.L.S.

- Tungsten Carbide/Ceramic



Operating Data

Maximum Pressure and Maximum Speed	See Diagram	
Maximum Speed NPT	1,500 RPM	1,500/min
Maximum Temperature	200°F	>200°F consult DEUBLIN

(Temperatures above 160°F pressure should not exceed 150 PSI (10 bar) and media must be in liquid form.)

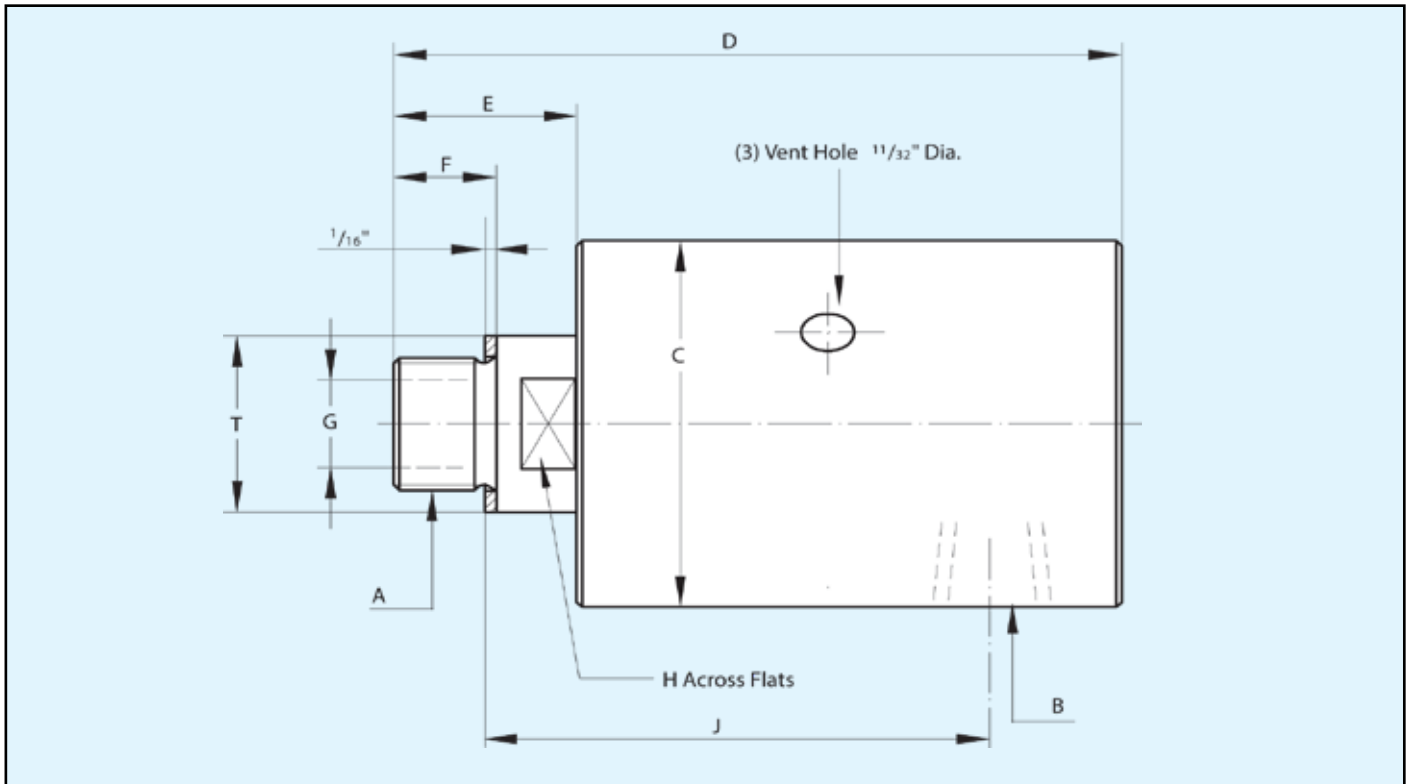
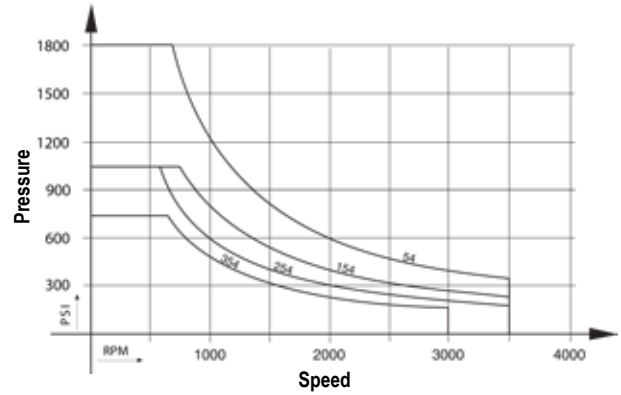

B Port NPT	Ordering Number		A Rotor Thread	C Dia.	D	E	F	G	H*	J	T	Shpg. Wt.
	Standard Model	E.L.S. Model										
3/8"	54-050-117	54-051-112	3/8" NPT RH	1 15/16"	4"	1 1/16"	5/8"	3/8"	19	3"	7/8"	1 1/2#
	54-050-178	54-051-110	G 3/8" (BSP) RH	49	101	26	16	9.5	19	71.5	22	1.1 Kg
1/2"	154-050-117	154-051-112	1/2" NPT RH	2 1/2"	4 15/16"	1 1/16"	7/8"	1/2"	24	3 3/4"	1 3/16"	2#
	154-050-178	154-051-110	G 1/2" (BSP) RH	64	123	34	19	12.7	24	89	30	1.8 Kg
3/4"	254-050-117	254-051-112	3/4" NPT RH	2 7/8"	5 7/16"	1 15/32"	7/8"	11/16"	30	4 1/16"	1 3/8"	5 3/4#
	254-050-178	254-051-110	G 3/4" (BSP) RH	73	135	34	19	17.5	30	98	35	2.6 Kg
1"	354-050-117	354-051-112	1" NPT RH	3 11/16"	6 9/16"	1 15/16"	1 1/8"	1"	36	4 7/8"	1 25/32"	11 1/4#
	354-050-178	354-051-110	G 1" (BSP) RH	94	161	43	22	25	36	117	45	5.1 Kg

Note: 1/4" & 1/2" available. *Metric

DEUBLIN

Model 927 High Pressure/ Low Torque Water Union

- Monoflow design
- Self-supported rotating union
- Axial housing connection
- Balanced mechanical seal
- Seal combination:
Tungsten Carbide/Tungsten Carbide
- Slinger and vents protect bearings
- Low torque design
- Stainless steel housing and rotor



Operating Data

Maximum Water Pressure	4,000 PSI	276 bar
Maximum Speed	2,000 RPM	2,000/min
Maximum Flow	4 GPM	15 L/min
Maximum Temperature	200°F	90°C

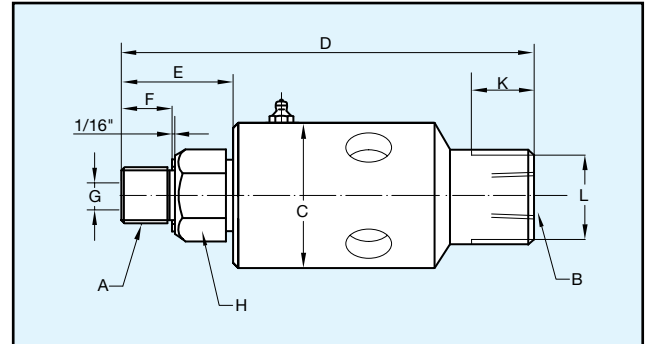

B Port NPT	Ordering Number	A Rotor Thread	C	D	E	F	G Rotor Hole	H* Across Flats	K	L Across Flats	Shpg. Wt.
3/8"	927-150-151	3/4"-16 UNF RH	2 1/4"	5 5/8"	1 1/8"	3/4"	3/8"	30	1"	1 1/4"	3#
	927-150-152	3/4"-16 UNF LH									

DEUBLIN

Model 22 Car Wash Union

- Monoflow design
- Self-supported rotating union
- Radial housing connection
- Seal combination:
Silicon Carbide/Silicon Carbide
- Stainless steel housing and rotor



Operating Data

Maximum Water Pressure**	1,500 PSI	105 bar
Maximum Speed**	250 RPM	250/min
Maximum Temperature	250°F	121°C

** Union is designed for continuous operation at either maximum speed or maximum pressure. If operating conditions are close to maximum pressure and speed simultaneously, consult **DEUBLIN**.

(Not suitable for overhead boom.)

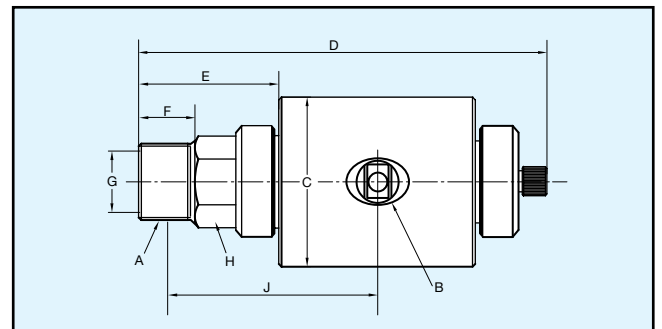

B Port NPT	Ordering Number	A Rotor Thread	C	D	E	F	G Rotor Hole	H* Across Flats	J Approx. Lock-up	Shpg. Wt.
3/4"	22-001-101	1/2" NPT RH	2 3/4"	5 5/8"	1 7/8"	1 1/16"	1/2"	30	2 1/16"	4 3/4#
3/4"	22-001-102	1/2" NPT LH								
3/4"	22-001-103	3/4" NPT RH	2 3/4"	5 3/4"	2 1/16"	7/8"	1/2"	30	2 7/8"	4 3/4#
3/4"	22-001-104	3/4" NPT LH								

*Metric

DEUBLIN

2", 2½", 3" & 4" Cartridge Water Unions

- Monoflow and duoflow design
- Self-supported rotating union
- Radial housing connection
- Balanced mechanical seal
- Steel-banded floating seal
- Easy and quick replacement of sealing components
- Full-media flow
- Vent slots
- Cast iron housing
- Steel rotor flanged/threaded
- Lubrication Guide page 55

Operating Data

Maximum Water Pressure	150 PSI	10 bar	
Maximum Speed		750 RPM	750/min
Torque for	Model 6200	4 ft.lbs	5.4 Nm
	Model 6250	7 ft.lbs	9.5 Nm
	Model 6300	8 ft.lbs	10.9 Nm
	Model 6400	10 ft.lbs	13.6 Nm

Maximum Temperature 250°F >250°F consult DEUBLIN

Seal Combination

- Carbon Graphite/Tungsten Carbide - Standard

Seal Combination - E.L.S.

- Silicon Carbide/Tungsten Carbide for severe conditions (poor water quality), max. temperature 200°F

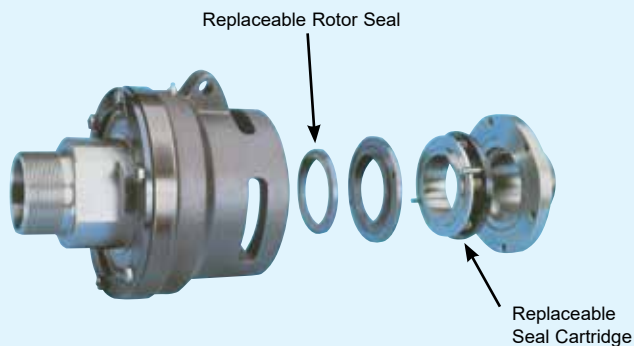
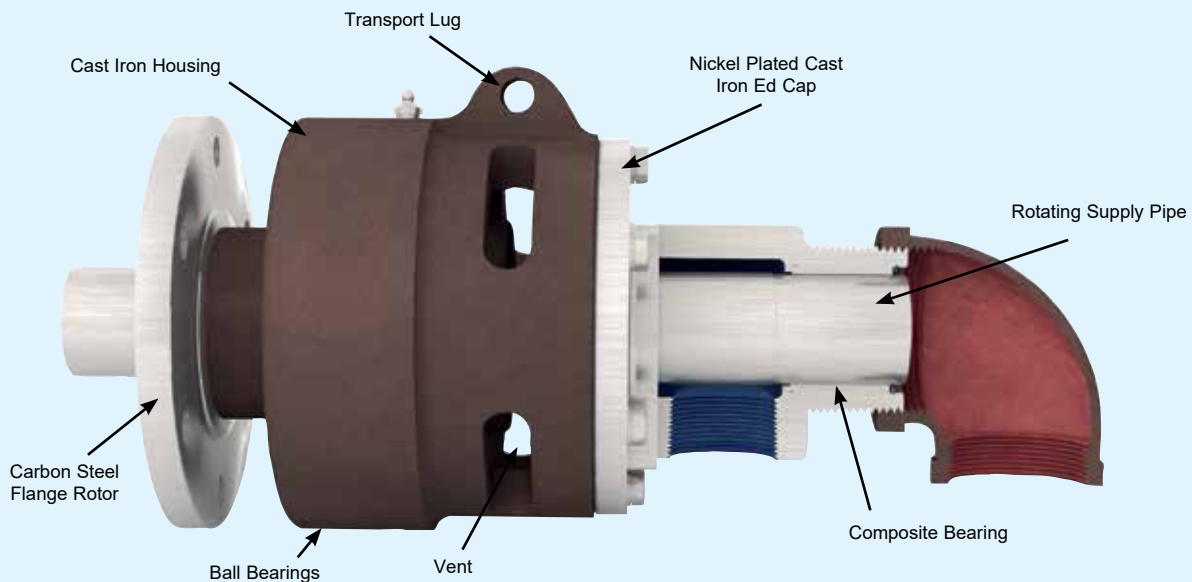

DEUBLIN Exclusive On-The-Machine Repair Cartridge

Seals are replaced quickly and easily. There's no need to remove hose connections or use special tools. Make sure the system is cold and pressureless! Simply remove 6 hex bolts and end cap, then remove floating seal cartridge and rotor seal face and replace with new seals. Rotor seal is keyed and sealed to the rotor with a built-in O-Ring. Replace end cap, hex bolts and safety wire. Detailed instructions available from DEUBLIN.

Monoflow Rotating Union

Threaded Rotor

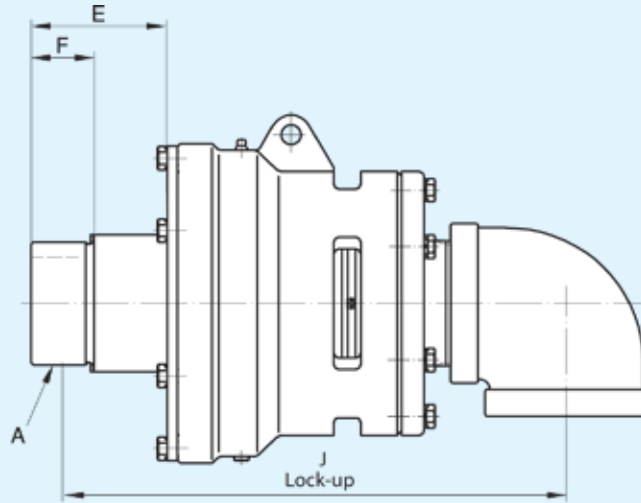

Flanged Rotor

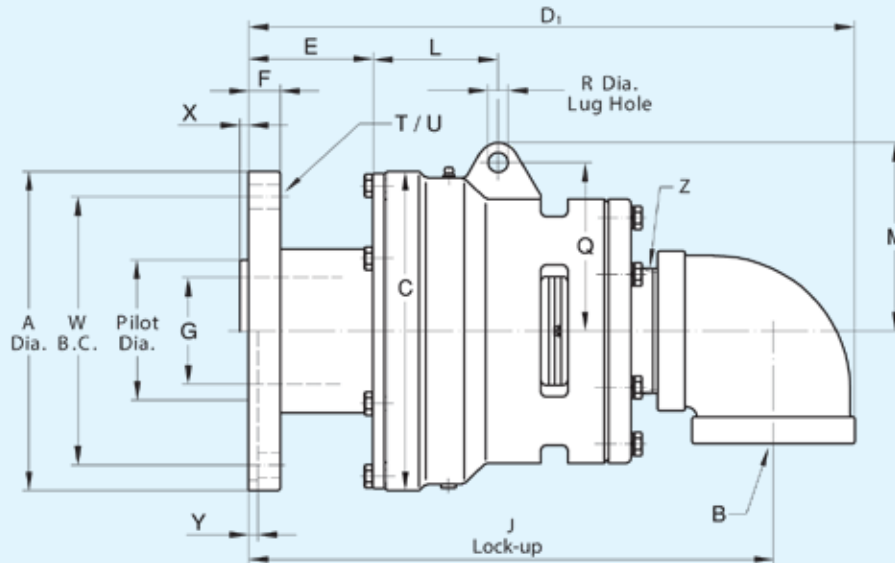

Flanged O-Ring

(supplied by DEUBLIN) for:

Model	O-Ring Size
6200	2-343 Viton
6250	2-343 Viton
6300	2-353 Viton
6400	2-361 Viton

B Port NPT	Ordering Number		A Rotor Thread	C	D ₁	E	F	G	J	L	M	Q	R	T	U	W	Pilot Dia.	X	Y	Z NPT	Shpg. Wt.
	Standard	E.L.S.																			
2"	6200-001-123	6200-016-123	2" NPT RH	5¼"	12"	2½"	1½"	1⅞"	9⅝"	2⅞"	3⅝"	3¼"	½"	-	-	-	-	-	-	2"	21#
	6200-001-135	6200-016-135	2" NPT LH																	2"	9.5 Kg
	6200-001-137	6200-016-137	G2"(BSP) RH	133	295	63.5	28.6	47	228	73	90	78	12.7	-	-	-	-	-	-	2"	9.5 Kg
	6200-001-139	6200-016-139	G2"(BSP) LH																	2"	9.5 Kg
	6200-001-115	6200-016-115	9" O.D. FLANGE	5¼"	12"	3¼"	1"	1⅞"	10¼"	2⅞"	3⅝"	3¼"	½"	4	1⅞"	6⅝"	8.317" 8.315"	-	¼"	2"	32#
2½"	6250-001-115	6250-018-115	2½"NPT RH	7"	14⅝"	3¼"	1⅞"	2⅞"	12"	3¾"	4⅞"	3⅝"	⅝"	-	-	-	-	-	-	2½"	44¼#
	6250-001-119	6250-018-119	2½"NPT LH																	2½"	44¼#
	6250-001-121	6250-018-121	G2½"(BSP) RH	178	371	82.5	38.1	60	290	95	113	98	14.3	-	-	-	-	-	-	2½"	20.2 Kg
	6250-001-123	6250-018-123	G2½"(BSP) LH																	2½"	20.2 Kg
		6250-001-300	6250-018-300	9" O.D. FLANGE	7"	15"	3⅝"	1"	2⅞"	12⅝"	3⅝"	4⅞"	3⅝"	⅝"	4	1⅞"	6⅝"	8.317" 8.315"	-	¼"	2½"
3"	6300-001-157	6300-015-157	3" NPT RH	9"	17⅞"	3⅞"	1⅞"	2⅞"	14"	3⅝"	5⅝"	4¾"	⅝"	-	-	-	-	-	-	3"	98#
	6300-001-158	6300-015-158	3" NPT LH																	3"	98#
	6300-001-161	6300-015-161	G3"(BSP) RH	229	433	95	44.4	73	335	87	135	121	14.3	-	-	-	-	-	-	3"	45.5 Kg
	6300-001-162	6300-015-162	G3"(BSP) LH																	3"	45.5 Kg
		6300-001-103	6300-015-103	9" O.D. FLANGE	9"	16¾"	3⅞"	⅞"	3"	14½"	3⅞"	5⅝"	4¾"	⅝"	6	1⅞"	7⅞"	4.004" 4.002"	¼"	-	3"
4"	6400-030-330	6400-042-330	10⅞" O.D. FLANGE	11"	19"	3"	⅞"	4"	16⅝"	3¾"	6⅞"	5¼"	⅝"	6	1⅞"	9"	4.749" 4.746"	.300	-	4"	156#

Note: Threaded Rotors Not For Calendar Service.

Flanged/Threaded Duoflow Rotating Pipe

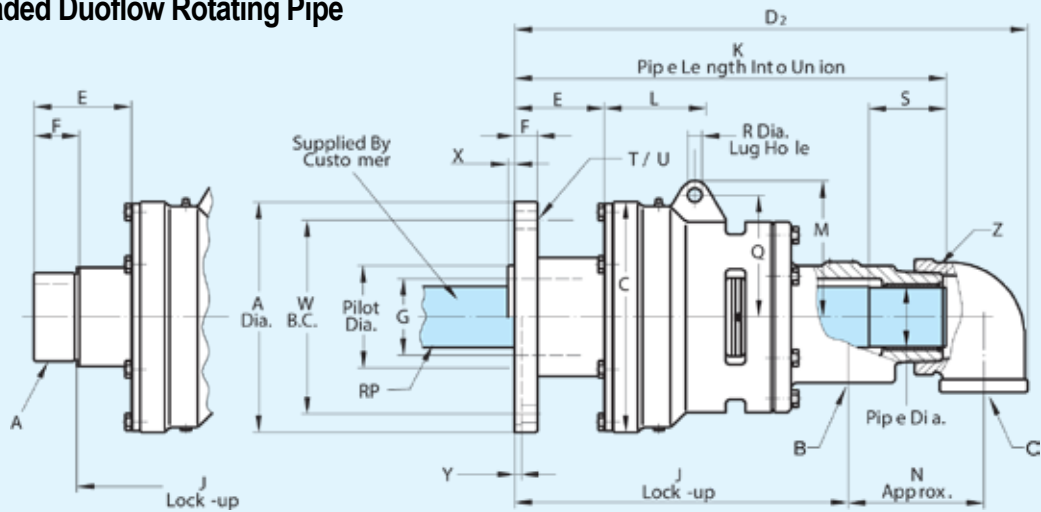

Duoflow Rotating Pipe Models

B & O Port NPT	Standard	E.L.S.	A	C	D ₂	E	F	G	J	K	L
(2) x 1"	6200-002-123	6200-030-123	2" NPT RH	5/4"	12 7/8"	2 15/16"	1 1/2"	1 7/8"	8"	10 5/8"	2 7/8"
	6200-002-135	6200-030-135	2" NPT LH								
	6200-002-137	6200-030-137	G2" (BSP) RH								
	6200-002-139	6200-030-139	G2" (BSP) LH								
	6200-002-115	6200-030-115	9" O.D. FLANGE.	5/4"	13 3/16"	3/4"	1"	1 7/8"	8 5/8"	10 15/16"	2 7/8"
(2) x 1 1/2"	6250-002-115	6250-030-115	2 1/2" NPT RH	7"	15 5/8"	3/4"	1 1/8"	2 3/8"	9 3/4"	13 3/8"	3 3/4"
	6250-002-119	6250-030-119	2 1/2" NPT LH								
	6250-002-121	6250-030-121	G2 1/2" (BSP) RH								
	6250-002-123	6250-030-123	G2 1/2" (BSP) LH								
	6250-002-300	6250-030-300	9" O.D. FLANGE	7"	16 1/4"	3 5/8"	1"	2 3/8"	10 9/16"	13 3/8"	3 3/4"
(2) x 2"	6300-002-157	6300-030-157	3" NPT RH	9"	20"	3 7/8"	1 1/8"	2 7/8"	12 1/4"	16 3/8"	3 1/16"
	6300-002-158	6300-030-158	3" NPT LH								
	6300-002-161	6300-030-161	G3" (BSP) RH	229	505	95	44.4	73	288.9	412	87
	6300-002-162	6300-030-162	G3" (BSP) LH								
		6300-002-103	6300-030-103	9" O.D. FLANGE	9"	19 9/16"	3 7/16"	7/8"	3"	12 3/4"	16"
(2) x 2 1/2"	6400-031-330	6400-051-330	10 7/8" O.D. FLANGE	11"	21 3/8"	3"	7/8"	4"	13 3/4"	17 1/2"	3 3/4"

Duoflow Fixed Pipe Models

B & O Port NPT	Standard	E.L.S.	A	C	D ₂	E	F	G	J	K	L
(2) x 1"	6200-011-123	6200-040-123	2" NPT RH	5/4"	12 7/8"	2 15/16"	1 1/2"	1 7/8"	8"	10 1/8"	2 7/8"
	6200-011-135	6200-040-135	2" NPT LH								
	6200-013-137	6200-020-137	G2" (BSP) RH								
	6200-013-139	6200-020-139	G2" (BSP) LH								
	6200-011-115	6200-040-115	9" O.D. FLANGE	5/4"	13 3/16"	3/4"	1"	1 7/8"	8 5/8"	10 1/16"	2 7/8"
(2) x 1 1/2"	6250-006-115	6250-040-115	2 1/2" NPT RH	7"	15 5/8"	3/4"	1 1/8"	2 3/8"	9 3/4"	13"	3 3/4"
	6250-006-119	6250-040-119	2 1/2" NPT LH								
	6250-025-121	6250-035-121	G2 1/2" (BSP) RH	178	403	82.5	38.1	60	228.6	330	95
	6250-025-123	6250-035-123	G2 1/2" (BSP) LH								
		6250-006-300	6250-040-300	9" O.D. FLANGE	7"	16 1/4"	3 5/8"	1"	2 3/8"	10 9/16"	13 3/8"
(2) x 2"	6300-006-157	6300-040-157	3" NPT RH	9"	20"	3 7/8"	1 1/8"	2 7/8"	12 1/4"	16 3/8"	3 1/16"
	6300-006-158	6300-040-158	3" NPT LH								
	6300-025-161	6300-035-161	G3" (BSP) RH	229	505	95	44.4	73	288.9	404	87
	6300-025-162	6300-035-162	G3" (BSP) LH								
		6300-006-103	6300-040-103	9" O.D. FLANGE	9"	19 9/16"	3 7/16"	7/8"	3"	12 3/4"	16"
(2) x 2 1/2"	6400-024-330	6400-054-330	10 7/8" O.D. FLANGE	11"	21 3/8"	3"	7/8"	4"	13 3/4"	17"	3 3/4"

Flanged/Threaded Duoflow Fixed Pipe

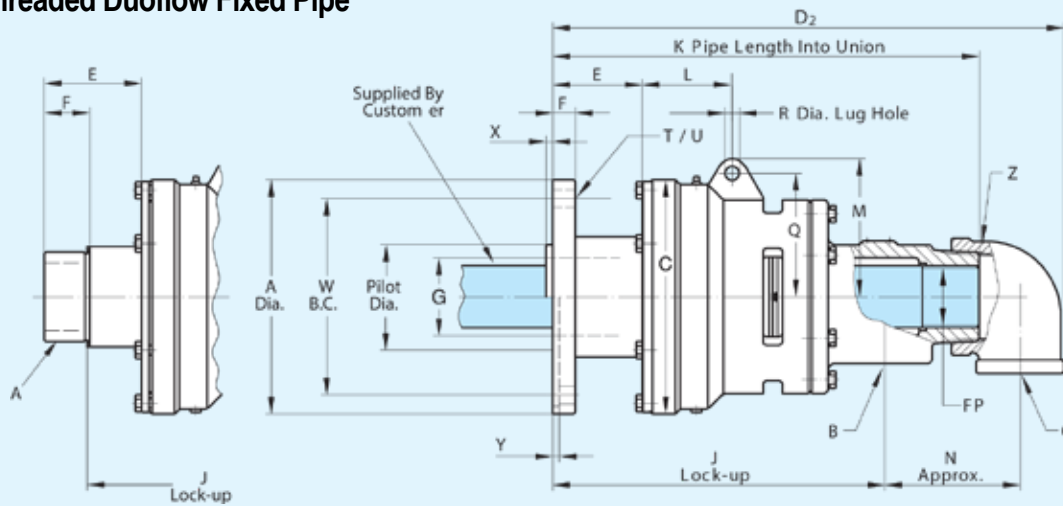

M	N	O NPT	Pipe Dia.	RP	Q	R	S	T	U	W	Pilot Dia.	X	Y	Z NPT	Shpg. Wt.
3 ³ / ₁₆ "	3 ³ / ₈ "	1"	1.245" 1.240"	1"	3 ¹ / ₁₆ "	1/2"	1 1/2"	-	-	-	-	-	-	2"	29#
90	86	1"	31.62 31.49	1"	78	12.7	38	-	-	-	-	-	-	2"	13.2 Kg
3 ³ / ₁₆ "	3 ³ / ₈ "	1"	1.245" 1.240"	1"	3 ¹ / ₁₆ "	1/2"	1 1/2"	4	1 ¹ / ₁₆ "	6 ³ / ₁₆ "	8.317" 8.315"	-	1/4"	2"	40#
4 ⁷ / ₁₆ "	4 ¹ / ₂ "	1 1/2"	1.867" 1.865"	1 1/2"	3 ³ / ₁₆ "	9/16"	1 5/8"	-	-	-	-	-	-	2 1/2"	55 1/2#
113	103	1 1/2"	47.42 47.37	1 1/2"	98	14.3	41	-	-	-	-	-	-	2 1/2"	25.2 Kg
4 ⁷ / ₁₆ "	4 ¹ / ₂ "	1 1/2"	1.867" 1.865"	1 1/2"	3 ³ / ₁₆ "	9/16"	1 5/8"	4	1 ¹ / ₁₆ "	6 ³ / ₁₆ "	8.317" 8.315"	-	1/4"	2 1/2"	70#
5 ⁵ / ₁₆ "	5 ⁵ / ₁₆ "	2"	2.308" 2.302"	2"	4 ³ / ₄ "	9/16"	2 3/4"	-	-	-	-	-	-	3"	105#
135	132	2"	58.62 58.47	2"	121	14.3	70	-	-	-	-	-	-	3"	47.7 Kg
5 ⁵ / ₁₆ "	5 ⁵ / ₁₆ "	2"	2.308" 2.302"	2"	4 ³ / ₄ "	9/16"	2 3/4"	6	1 ¹ / ₁₆ "	7 ⁹ / ₁₆ "	4.004" 4.002"	1/4"	-	3"	120#
6 ¹ / ₈ "	5 ³ / ₄ "	2 1/2"	2.745" 2.742"	2 1/2"	5 ¹ / ₄ "	5/8"	2 1/2"	6	1 ³ / ₁₆ "	9"	4.749" 4.746"	.300"	-	4"	168#

M	N	O NPT	FP	Q	R	T	U	W	Pilot Dia.	X	Y	Z NPT	Shpg. Wt.
3 ³ / ₁₆ "	3 ³ / ₈ "	1"	1" NPT	3 ¹ / ₁₆ "	1/2"	-	-	-	-	-	-	2"	29#
90	86	1"	G1 (BSP)	78	12.7	-	-	-	-	-	-	2"	13.2 Kg
3 ³ / ₁₆ "	3 ³ / ₈ "	1"	1" NPT	3 ¹ / ₁₆ "	1/2"	4	1 ¹ / ₁₆ "	6 ³ / ₁₆ "	8.317" 8.315"	-	1/4"	2"	40#
4 ⁷ / ₁₆ "	4 ¹ / ₂ "	1 1/2"	1 1/2" NPT	3 ³ / ₁₆ "	9/16"	-	-	-	-	-	-	2 1/2"	55 1/2#
113	103	1 1/2"	G1 1/2" (BSP)	98	14.3	-	-	-	-	-	-	2 1/2"	25.2 Kg
4 ⁷ / ₁₆ "	4 ¹ / ₂ "	1 1/2"	1 1/2" NPT	3 ³ / ₁₆ "	9/16"	4	1 ¹ / ₁₆ "	6 ³ / ₁₆ "	8.317" 8.315"	-	1/4"	2 1/2"	70#
5 ⁵ / ₁₆ "	5 ⁵ / ₁₆ "	2"	2" NPT	4 ³ / ₄ "	9/16"	-	-	-	-	-	-	3"	105#
135	132	2"	G2" (BSP)	121	14.3	-	-	-	-	-	-	3"	47.7 Kg
5 ⁵ / ₁₆ "	5 ⁵ / ₁₆ "	2"	2" NPT	4 ³ / ₄ "	9/16"	6	1 ¹ / ₁₆ "	7 ⁹ / ₁₆ "	4.004" 4.002"	1/4"	-	3"	120#
6 ¹ / ₈ "	5 ³ / ₄ "	2 1/2"	2 1/2" NPT	5 ¹ / ₄ "	5/8"	6	1 ³ / ₁₆ "	9"	4.749" 4.746"	.300"	-	4"	168#



DEUBLIN

F Series 5" Water Union

- Monoflow and duoflow design
- Self-supported rotating union
- Balanced mechanical seal
- Seal combination:
Carbon Graphite/Tungsten Carbide
- Two widely-spaced ball bearings
- Labyrinth seal protects bearings
- Cast iron housing
- High corrosion resistant
- Steel flanged rotor
- On-the-machine seal replacement capability
- Inlet/outlet flange:
standard ANSI
optional DIN, JIS
- Special designs up to 12" available upon request

Operating Data

Maximum Water Pressure*	230 PSI	16 bar
Maximum Speed*	1,000 RPM	1,000/min
Maximum Temperature	250°F	>250°F consult DEUBLIN

*Union is designed for continuous operation at either maximum speed or maximum pressure. If operating conditions are close to maximum pressure and speed simultaneously, consult **DEUBLIN**.

Monoflow Rotating Union

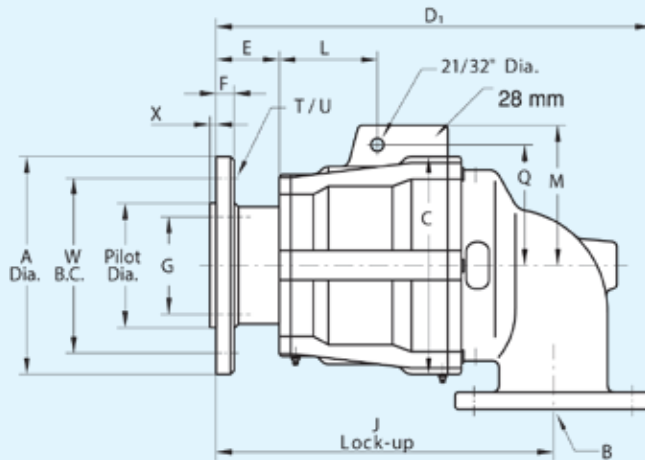

Duoflow Rotating Union

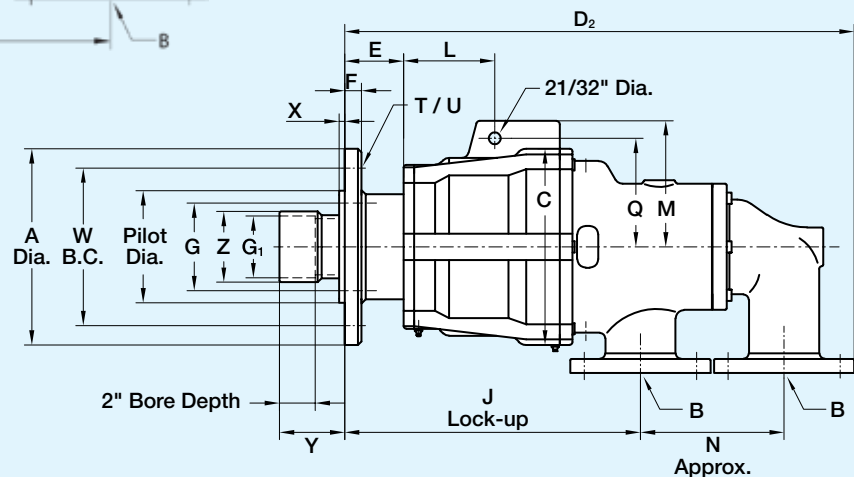

Monoflow Union

B Port	Ordering No.	A	C	D ₁	E	F	G	J	L	M	Q	T	U	W	X	Pilot Dia.	Shpg. Wt.
5" ANSI	F127-011-200	11"	11"	23"	3 ¹¹ / ₃₂ "	1"	4 ²⁹ / ₃₂ "	17 ²⁹ / ₃₂ "	5 ¹ / ₈ "	7 ³ / ₃₂ "	6 ¹ / ₃₂ "	6	2 ³ / ₃₂ "	8 ²⁷ / ₃₂ "	5 ¹ / ₁₆ "	6.295" 6.291"	220#

Duoflow Union

B Port	Ordering No.	A	C	D ₂	E	F	G ₁	J	L	M	N	Q	T	U	W	X	Y	Z	Pilot Dia.	Shpg. Wt.
(2) 3" ANSI	F127-023-204-701	11"	11"	28 ¹ / ₂ "	3 ¹¹ / ₃₂ "	1"	3.480" 3.476"	16 ²¹ / ₃₂ "	5 ¹ / ₈ "	7 ³ / ₃₂ "	8"	6 ¹ / ₃₂ "	6	2 ³ / ₃₂ "	8 ²⁷ / ₃₂ "	5 ¹ / ₁₆ "	3 ²¹ / ₃₂ "	3 ³¹ / ₃₂ "	6.295" 6.291"	264#

DEUBLIN

2400 Series Rotating Union

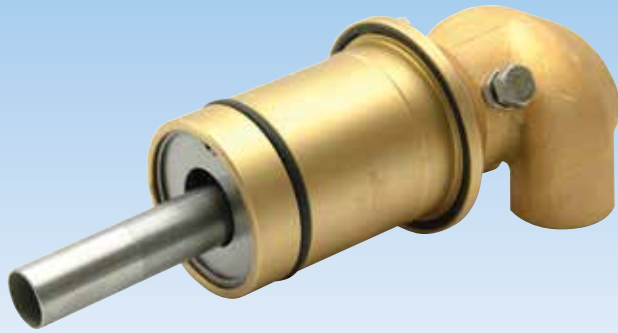

- Monoflow and duoflow design
- In-the-shaft mounted
- Self-supported rotating union
- Flanged housing or mounted with retaining plate
- Balanced mechanical seal
- Seal combination: Silicon Carbide/Silicon Carbide
- Brass housing and elbow
- Stainless steel rotor and supply pipe
- Engineered sleeve bearing
- Full-media flow
- Easily field repairable

Operating Data

Maximum Water Pressure	150 PSI	10 bar
Maximum Speed	100 RPM	100/min
Maximum Temperature	250°F	>250°F consult DEUBLIN

Monoflow Rotating Union

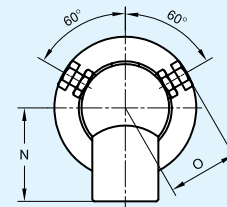
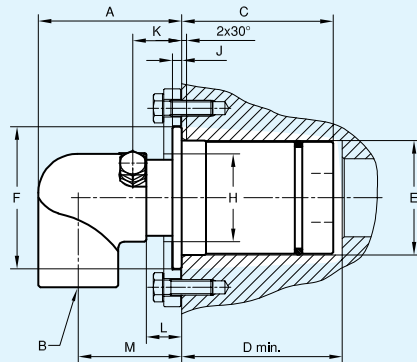

Duoflow Rotating Union

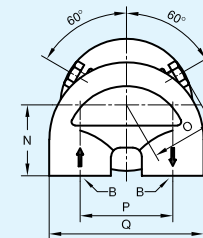
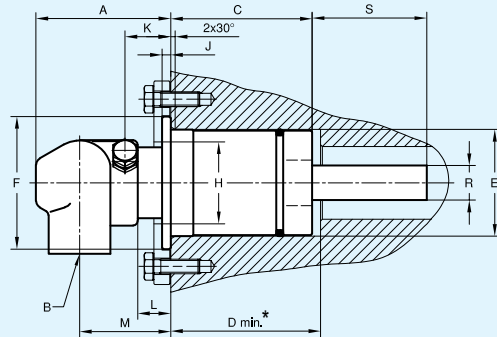

	B Port	Ordering Number	A	C	D*	E Ø*	F Ø	H Ø	J	K	L	M	N	O	P	Q	R Ø	S	Shpg. Wt.
Monoflow	3/4" NPT	2420-001-125	2 2/64"	2 3/8"	2 1/8"	1.825 1.815	2 1/8"	1 15/16"	3/8"	1 1/32"	3/4"	1 2 1/2"	1 13/16"	1 1/8"	-	-	-	-	1 1/2#
	G 3/4" (BSP)	2420-001-139	59	60	62	46.35 46.10	59	49	5	26	19	42	46	36	-	-	-	-	.7 Kg
	1" NPT	2425-001-281	2 15/16"	3 1/8"	3 1/4"	2.323 2.313	2 7/8"	1 1/8"	3/8"	1 1/32"	3/4"	2 1/8"	1 13/16"	1 1/8"	-	-	-	-	3 1/2#
	G 1" (BSP)	2425-001-172	75	78	83	59.00 58.75	73	36	5	26	19	54	46	39	-	-	-	-	1.6 Kg
Duoflow	3/4" NPT	2420-001-135-180	2 15/16"	2 3/8"	2 1/8"	1.825 1.815	2 5/8"	1 15/16"	3/8"	1 1/32"	3/4"	2"	1 17/32"	1 1/8"	2"	3 1 1/2"	.511 .510	1 15/16"	2#
	G 3/4" (BSP)	2420-001-141-180	75	60	62	46.35 46.10	59	49	5	26	19	51	39	36	51	85	13.00 12.95	49	.9 Kg
	3/4" NPT	2425-001-283-180	2 15/16"	3 1/8"	3 1/4"	2.323 2.313	2 7/8"	1 1/8"	3/8"	1 1/32"	3/4"	2"	1 17/32"	1 1/8"	2"	3 1 1/2"	.748 .746	2 1/2"	4#
	G 3/4" (BSP)	2425-001-177-180	75	78	83	59.00 58.75	73	36	5	26	19	51	39	39	51	85	19.00 18.94	63.5	1.8 Kg
	1" NPT	2440-001-301-254	3 3/8"	3 3/8"	3 1 1/8"	2.805 2.795	3 3/8"	2"	3/8"	1 1/32"	3/4"	2 1 1/16"	1 11/16"	1 13/16"	2 1/2"	4 1/8"	1.130 1.125	1 7/8"	9#
	G 1" (BSP)	2440-001-306-254	98	87	94	71.25 71.00	86	51	5	26	19	68	43	46	64	105	28.70 28.58	48	4 Kg

*Denotes Shaft Dimension

DEUBLIN

N Series Steam and Hot Oil Unions

- Monoflow design: N10
- Monoflow and duoflow design: N12
- Self-supported rotating union
- Large carbon graphite bearing
- Pressurized spherical carbon graphite seal
- Cast iron housing
- Stainless steel rotor

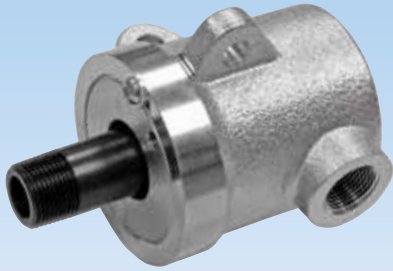

Operating Data

Maximum Steam Pressure***	250 PSI	17 bar
Maximum Steam Temperature	400°F	200°C
Maximum Hot Oil Pressure***	100 PSI	7 bar
Maximum Speed***	750 RPM	750/min
Maximum Hot Oil Temperature	450°F	232°C

*** Union is designed for continuous operation at either maximum speed or maximum pressure. If operating conditions are close to maximum pressure and speed simultaneously, consult **DEUBLIN**.

Monoflow Union

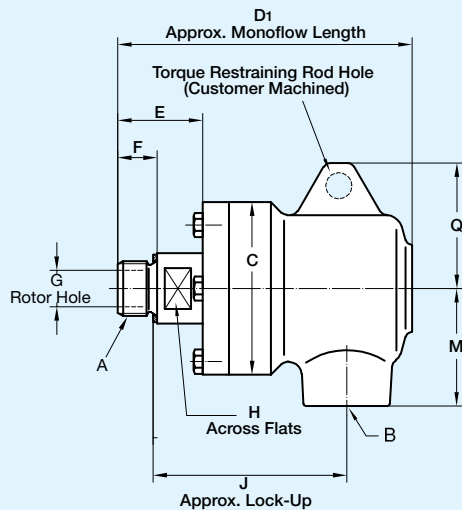

Duoflow Union

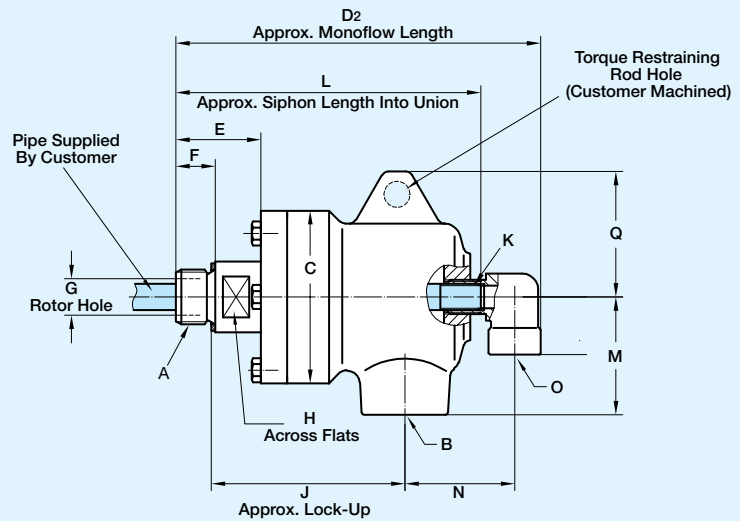

	B Port NPT	Ordering Number		A Rotor Thread	C Dia.	D ₁	D ₂	E	F	G Rotor Hole	H**	J*	K	L*	M	N	O	Q	Shpg. Wt.	
		Steam Service	Hot Oil 450°F Max.																	
Monoflow	3/8"	N10-020-214	N10-021-214	3/8" NPT RH	23/8"	4 1/8"	-	1 1/32"	19/32"	13/32"	17	3"	-	-	1 1/16"	-	-	1 21/32"	2.4#	
		N10-020-215	N10-021-215	3/8" NPT LH																
		N10-020-210	N10-021-210	G 3/8" (BSP) RH	60	105	-	31	15	10	17	68.5	-	-	40	-	-	42	1.1 Kg	
		N10-020-211	N10-021-211	G 3/8" (BSP) LH																
	1/2"	N12-020-214	N12-021-214	1/2" NPT RH	2 19/32"	4 1/16"	-	1 1/32"	19/32"	9/16"	22	3 3/8"	-	-	1 25/32"	-	-	1 29/32"	3.1#	
		N12-020-215	N12-021-215	1/2" NPT LH																
		N12-020-210	N12-021-210	G 1/2" (BSP) RH	66	112.5	-	32.5	15	14	22	74	-	-	45	-	-	48	1.4 Kg	
		N12-020-211	N12-021-211	G 1/2" (BSP) LH																
Duoflow	1/2"	N12-022-214-701	N12-023-214-701	1/2" NPT RH	2 19/32"	-	5 1/2"	1 1/32"	19/32"	9/16"	22	3 3/8"	1/8" NPT	4 19/32"	1 25/32"	1 21/32"	1/4" NPT	1 29/32"	3.1#	
		N12-022-215-701	N12-023-215-701	1/2" NPT LH																
		N12-022-210-701	N12-023-210-701	G 1/2" (BSP) RH	66	-	139.5	32.5	15	14	22	74	1/8" NPT	116.5	45	42	1/4" NPT	48	1.4 Kg	
		N12-022-211-701	N12-023-211-701	G 1/2" (BSP) LH																

*Dimensions for NPT Rotor Threads are from Wrench Tight Engagement. **Metric

DEUBLIN

9000 Series Steam Unions

- Monoflow and duoflow design
- Self-supported rotating union
- Spherical Carbon Graphite seal
- Seal wear indicator allows preventive maintenance
- 2 torque lugs on the housing
- Nickel-plated cast iron housing
- Steel rotor blackened for steam service



Operating Data

Maximum Saturated Steam Pressure*	150 PSI	10 bar
Maximum Saturated Steam Temperature	365°F	185°C
Maximum Hot Oil Pressure*	100 PSI	7 bar
Maximum Speed*	400 RPM	400/min
Maximum Hot Oil Temperature	450°F	232°C

* Union is designed for continuous operation at either maximum speed or maximum pressure. If operating conditions are close to maximum pressure and speed simultaneously, consult **DEUBLIN**.

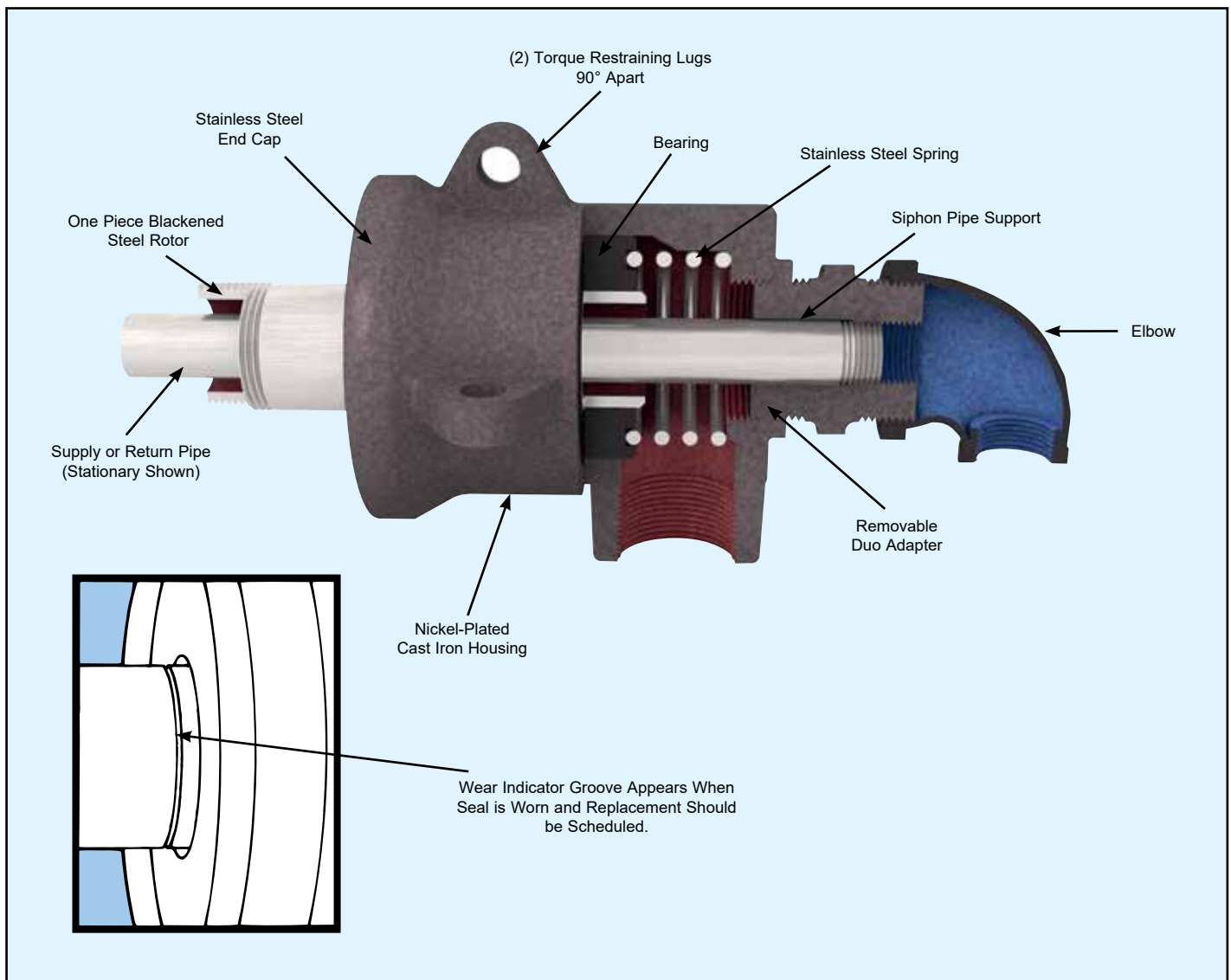

9000 Series Monoflow Union Specifications

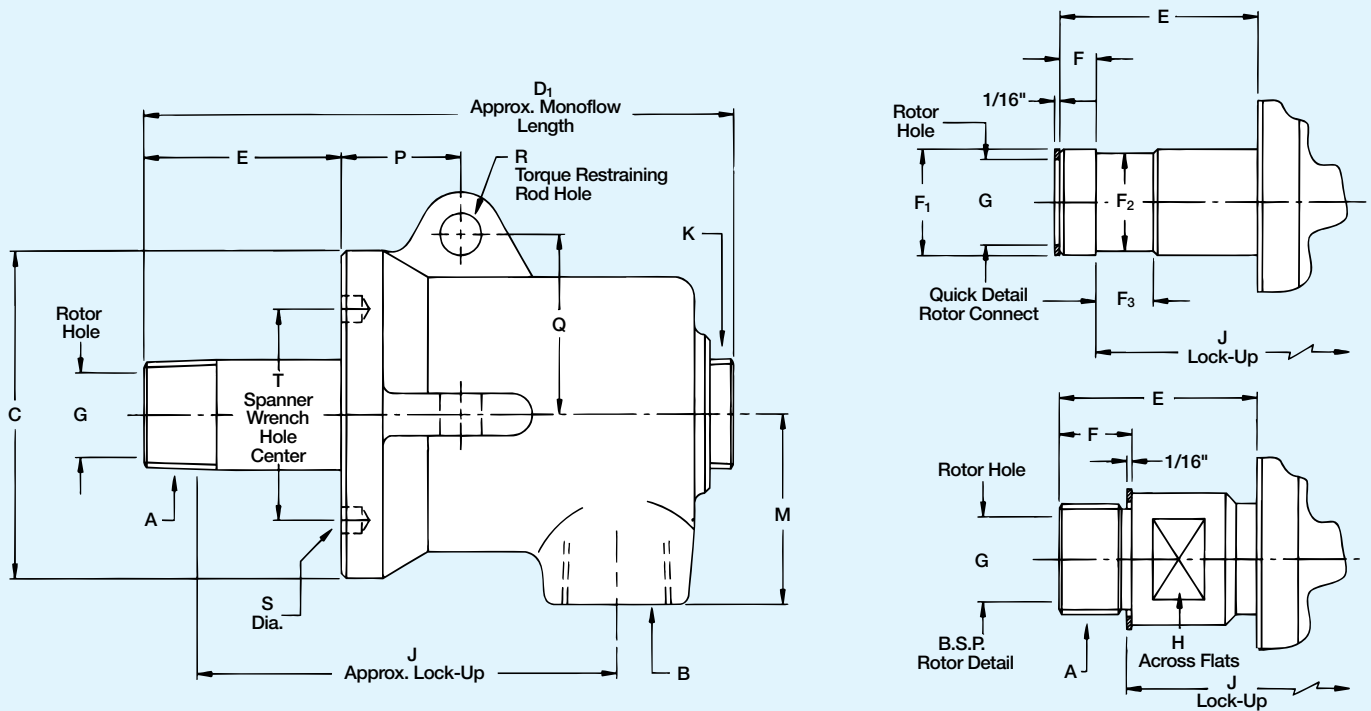

Hot Oil Service – Use Type C. Download PDF from website

B Port	Ordering Number		A Rotor Thread	C	D ₁	D ₂	E	F	F ₁	F ₂	F ₃	G	H*	J	K
	Steam Service														
3/4" NPT	9075-001-106		3/4" NPT RH	3 7/8"	6"	8 5/8"	1 7/8"	-	-	-	-	2 1/32"	-	4 5/8"	1" NPT
	9075-001-107		3/4" NPT LH												
	9075-001-117		QUICK CONNECT												
G 3/4" (BSP)	9075-008-110		G 3/4" (BSP) RH	87	153	219	48	19	-	-	-	16.6	25	108	G 1"
	9075-008-111		G 3/4" (BSP) LH												
1" NPT	9100-001-103		1" NPT RH	3 13/16"	7 1/4"	9 7/8"	2 3/8"	-	-	-	-	1"	-	5 3/8"	1" NPT
	9100-001-109		1" NPT LH												
	9100-001-121		QUICK CONNECT												
G 1" (BSP)	9100-008-113		G 1" (BSP) RH	97	184	251	60	22	-	-	-	25	32	128	G 1"
	9100-008-112		G 1" (BSP) LH												
1 1/4" NPT	9125-001-109		1 1/4" NPT RH	4 7/8"	8 3/8"	11 1/8"	2 1/2"	-	-	-	-	1 1/4"	-	5 7/8"	1 1/2" NPT
	9125-001-110		1 1/4" NPT LH												
	9125-001-126		QUICK CONNECT												
G 1 1/4" (BSP)	9125-008-118		G 1 1/4" (BSP) RH	112	206	282	64	25	-	-	-	32	38	138	G 1 1/2"
	9125-008-119		G 1 1/4" (BSP) LH												
1 1/2" NPT	9150-001-103		1 1/2" NPT RH	5 1/4"	9"	12 5/8"	2 1/2"	-	-	-	-	1 1/2"	-	6 5/8"	1 1/2" NPT
	9150-001-104		1 1/2" NPT LH												
	9150-001-117		QUICK CONNECT												
G 1 1/2" (BSP)	9150-008-113		G 1 1/2" (BSP) RH	133	229	320	64	28	-	-	-	38	46	154	G 1 1/2"
	9150-008-114		G 1 1/2" (BSP) LH												
2" NPT	9200-001-102		2" NPT RH	6 3/32"	10 1/16"	13 3/16"	2 5/8"	-	-	-	-	1 15/16"	-	7 3/32"	1 1/2" NPT
	9200-001-111		2" NPT LH												
	9200-001-121		QUICK CONNECT												
G 2" (BSP)	9200-008-117		G 2" (BSP) RH	154	255	341	67	30	-	-	-	49	60	166	G 1 1/2"
	9200-008-118		G 2" (BSP) LH												

9000 Series Duoflow Union Specifications

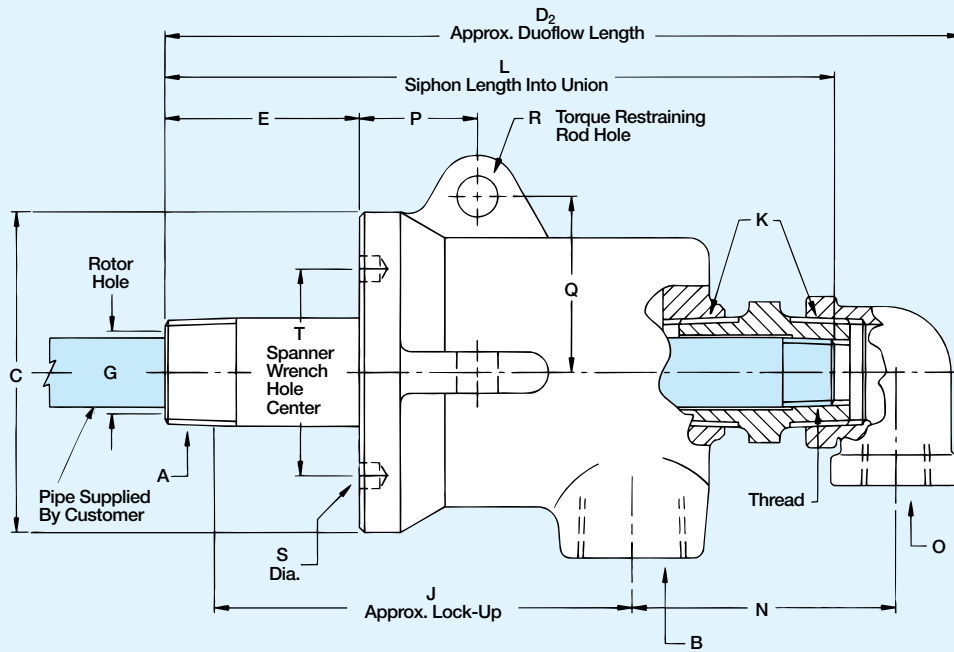

Fixed Siphon Detail

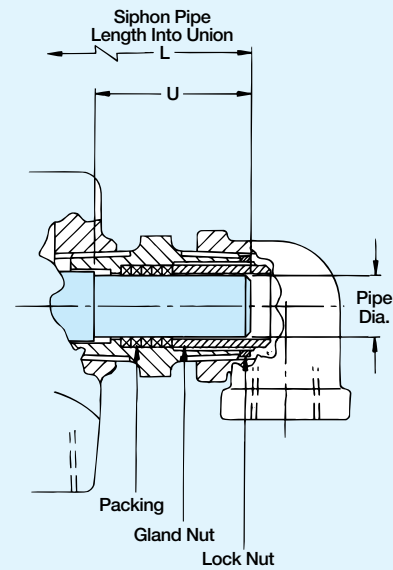

Rotating Siphon Detail

P	Q	R	S	T	Fixed Siphon			Rotating Siphon				M	N	O	Shpg. Wt.	
					Elbow Suffix	Thread	L	Elbow Suffix	Pipe Size	Pipe Dia.	U					L
1½"	1 15/16"	15/32"	17/64"	2¼"	-400	¼" NPT	7¼"	-402	¼"	.500" .495"	2"	7¼"	2"	2¾"	½" NPT	8#
1½"	1 15/16"	15/32"	17/64"	2¼"	-400	¼" NPT	7¼"	-402	¼"	.500" .495"	2"	7¼"	2"	2¾"	½" NPT	8#
38	49	12	7	57	-600	G¼" (BSP)	181	-620	¼"	13.0 12.9	51	175	51	60	G½" (BSP)	3.6 Kg
1½"	2 1/8"	17/32"	5/16"	2½"	-400	¼" NPT	8"	-403	3/8"	.663" .657"	2"	8¾"	2¼"	3 5/16"	½" NPT	10#
					-401	3/8" NPT										
1½"	2 1/8"	17/32"	5/16"	2½"	-400	¼" NPT	8"	-403	3/8"	.663" .657"	2"	8¾"	2¼"	3 5/16"	½" NPT	10#
					-401	3/8" NPT										
38	54	13.5	8	63	-600	G½" (BSP)	210	-620	3/8"	16.0 15.9	51	206	57	84	G½" (BSP)	4.5 Kg
					-601	G¾" (BSP)										
1 5/8"	2 3/8"	17/32"	1 1/2"	3"	-400	½" NPT	8¾"	-402	½"	.809" .803"	2 3/4"	9¾"	3"	3 3/8"	¾" NPT	15#
1 5/8"	2 3/8"	17/32"	1 1/2"	3"	-400	½" NPT	8 1/2"	-402	½"	.809" .803"	2 3/4"	9 1/2"	3"	3 3/8"	¾" NPT	15#
42	60	13.5	8.7	76	-600	G½" (BSP)	238	-620	½"	20.0 19.9	60	230	76	98	G¾" (BSP)	6.8 Kg
					-400	½" NPT										
2 3/16"	2 1/8"	2 1/32"	1 1/32"	3 1/2"	-400	½" NPT	10 1/2"	-403	3/4"	.997" .991"	2 1/2"	11 1/16"	3 1/2"	4 5/8"	¾" NPT	25#
					-401	¾" NPT										
2 3/16"	2 1/8"	2 1/32"	1 1/32"	3 1/2"	-400	½" NPT	10 1/2"	-403	3/4"	.997" .991"	2 1/2"	11 1/16"	3 1/2"	4 5/8"	¾" NPT	25#
					-401	¾" NPT										
55	73	16.7	8.7	89	-600	G½" (BSP)	262	-621	3/4"	26.0 25.9	63	255	89	117	G¾" (BSP)	11.5 Kg
					-601	G¾" (BSP)										
2 1/16"	3 1/16"	5/8"	-	-	-400	½" NPT	10 7/8"	-403	3/4"	.997" .991"	2 1/2"	12 5/8"	3 3/16"	5"	¾" NPT	31#
					-401	¾" NPT										
2 1/16"	3 1/16"	5/8"	-	-	-400	½" NPT	11 1/4"	-403	3/4"	.997" .991"	2 1/2"	13"	3 3/16"	5"	¾" NPT	31#
					-401	¾" NPT										
62	87	16	-	-	-600	G½" (BSP)	284	-621	3/4"	26.0 25.9	63	276	87	127	G¾" (BSP)	14 Kg
					-601	G¾" (BSP)										

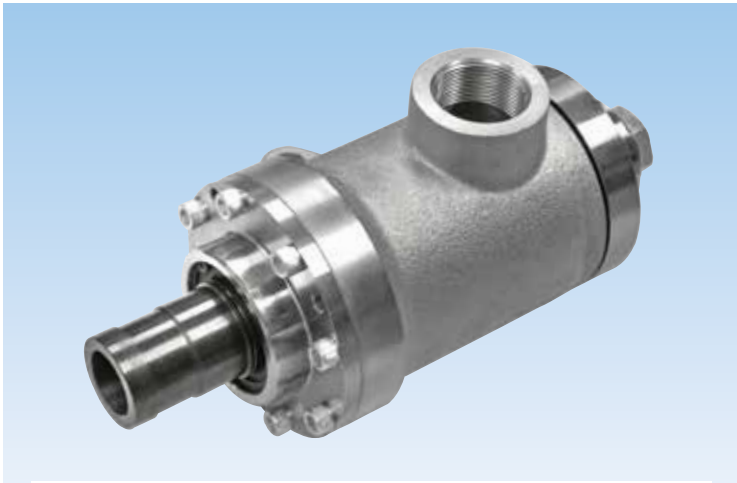

DEUBLIN

HPS Series for High Pressure Steam Service in Corrugators

- Monoflow and duoflow design
- Self-supported rotating union
- Seals and bearings made of special Carbon Graphite
- Convex seal ring better suited to handle mechanical and thermal shock
- External mechanism to adjust siphon pipe through end cap
- Nickel-plated front and rear end cap
- Nickel-plated ductile iron housing
- Stainless steel spring
- Heavy duty steel rotor design
- Dual bearings for extended service life

Operating Data

Maximum Saturated Steam Pressure	250 PSI	17 bar
Maximum Speed	400 RPM	400/min
Maximum Temperature	400°F	200°C

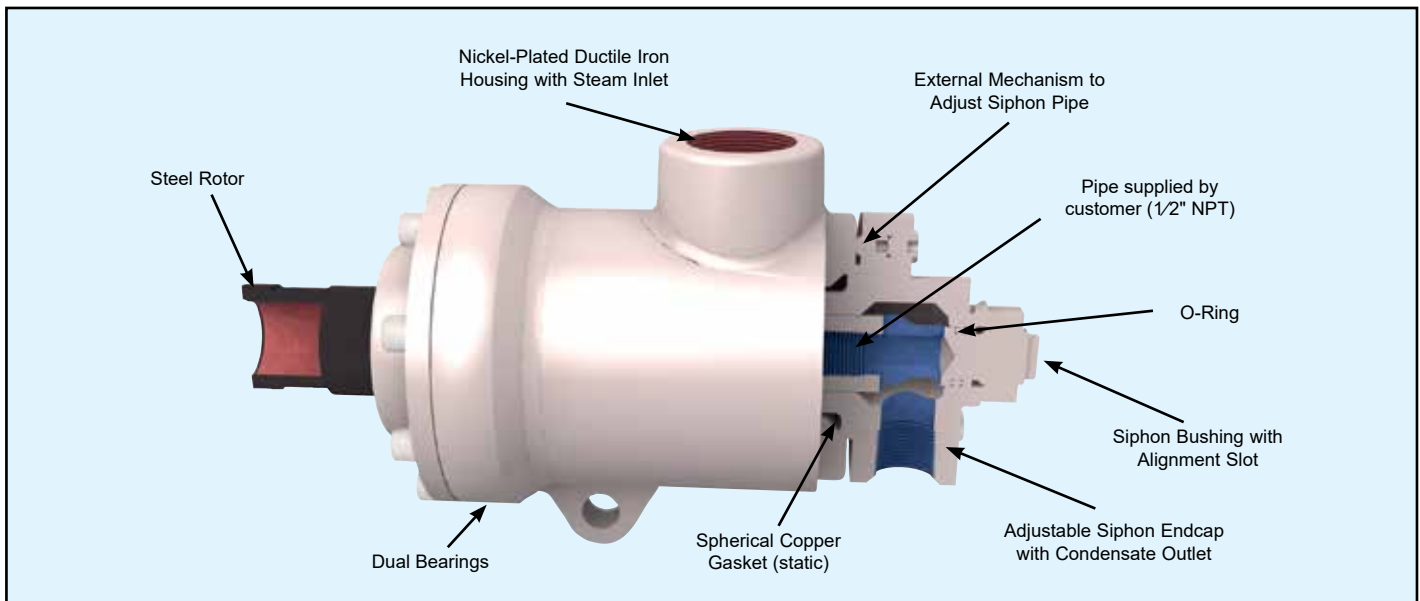

Flange Adapter Kits

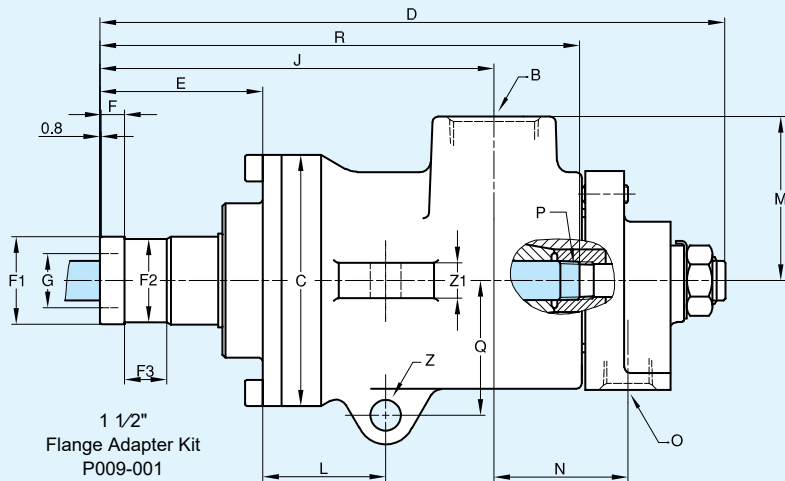
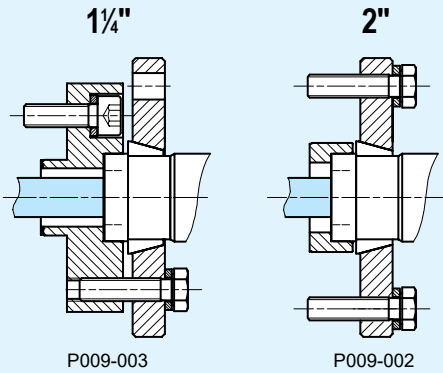

B Port NPT	O Port NPT	Ordering No.	C Ø	D	E	F	F1 Ø	F2	F3	G Ø	J	L	M	N	P	Q	R	Z Ø	Z1	Shpg. Wt.
1 1/2"	3/4"	C15D-004-02-3A	5 3/8"	13 3/8"	3 15/32"	1/2"	1.870" 1.868"	1.779" 1.775"	29/32"	1 5/16"	8 13/32"	2 5/8"	3 1/2"	2 7/8"	1/2" NPT	2 7/8"	10 1/4"	2 1/2"	1 3/16"	37#

DEUBLIN

H Series Steam and Hot Oil Unions

- Monoflow and duoflow design
- Self-supported rotating union
- Convex seal ring better suited to handle mechanical and thermal shock
- Two widely-spaced graphite bearings
- H57 - H127 optional with sight glasses in the end cap for visual inspection of condensate removal
- Seal wear indicator allows preventive maintenance
- Flanged or threaded rotor available
- Cast iron housing
- Stainless steel rotor
- For steam and hot oil applications in paper, plastic and textile industries and open gear paper machines



Operating Data 3/4" – 2"

Maximum Saturated Steam Pressure	150 PSI	10 bar
Maximum Speed Saturated Steam Service	400 RPM	400/min
Maximum Saturated Steam Temperature	365°F	185°C
Maximum Hot Oil Pressure	100 PSI	7 bar
Maximum Speed Hot Oil Service	400 RPM	400/min
Maximum Hot Oil Temperature	450°F	232°C

Operating Data 2 1/2" – 5"

Maximum Saturated Steam Pressure	150 PSI	10 bar
Maximum Speed Saturated Steam Service	180 RPM	180/min
Maximum Saturated Steam Temperature	365°F	185°C
Maximum Hot Oil Pressure	100 PSI	7 bar
Maximum Speed Hot Oil Service	350 RPM	350/min
Maximum Hot Oil Temperature	450°F	232°C

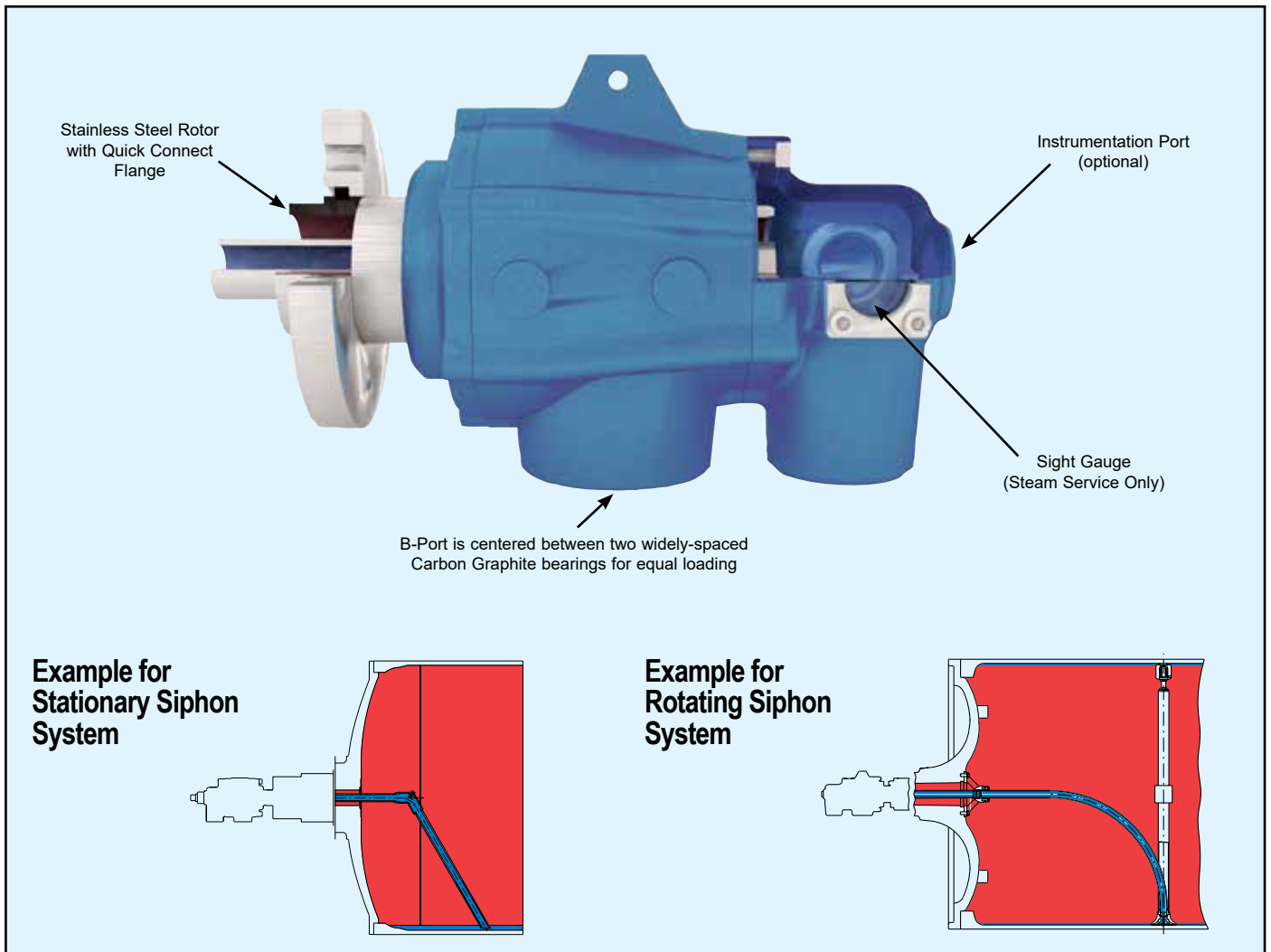

Example for Stationary Siphon System

Example for Rotating Siphon System

Monoflow Rotating Union Models Size H20 – H40

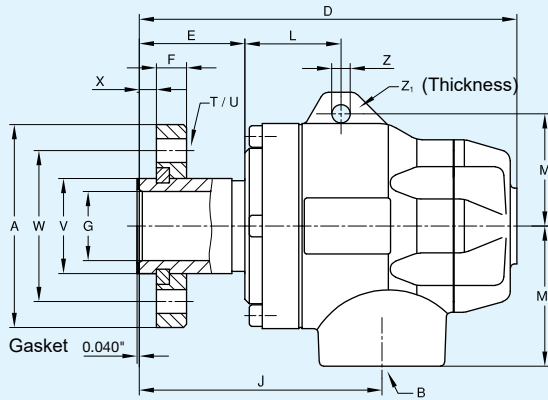

Models Size H57 – H87

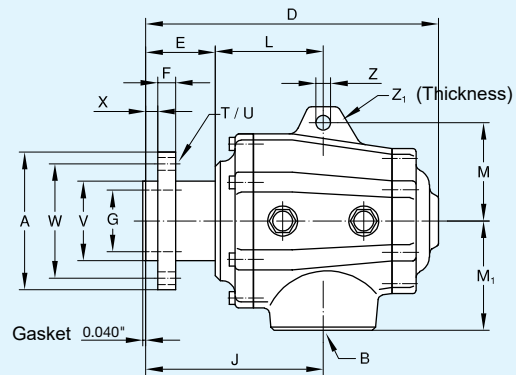

Models Size H107 and H127

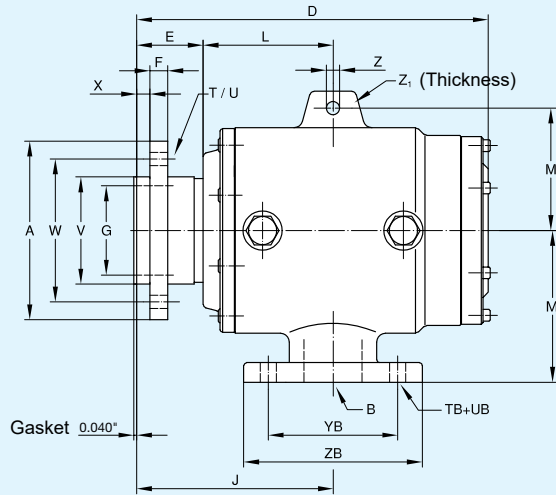

Monoflow Rotating Unions

Size	B Port	Monoflow	A	D	E	F	G	J	L	M	M ₁
¾"	¾" NPT	H20	2 ³ / ₃₂ "	5 ¹ / ₂ "	1 ¹ / ₁₆ "	1 ⁵ / ₃₂ "	2 ³ / ₃₂ "	3 ³ / ₄ "	2 ⁵ / ₁₆ "	1 ²⁵ / ₃₂ "	1 ³ / ₃₂ "
1"	1" NPT	H25	3 ¹ / ₁₆ "	6 ¹ / ₂ "	1 ⁷ / ₃₂ "	1 ⁵ / ₃₂ "	3 ¹ / ₃₂ "	3 ³ / ₃₂ "	1 ²³ / ₃₂ "	1 ³ / ₃₂ "	2 ³ / ₈ "
1¼"	1¼" NPT	H32	3 ¹ / ₁₆ "	6 ³ / ₈ "	1 ¹⁵ / ₁₆ "	9 ¹ / ₁₆ "	1 ¹ / ₄ "	4 ¹ / ₁₆ "	1 ³ / ₄ "	2 ¹ / ₁₆ "	2 ⁵ / ₁₆ "
1½"	1½" NPT	H40	3 ²⁹ / ₃₂ "	8 ¹ / ₂ "	2 ³ / ₃₂ "	9 ¹ / ₁₆ "	1 ¹ / ₂ "	5 ³ / ₈ "	2"	2 ³ / ₄ "	2 ¹⁵ / ₁₆ "
2"	2" NPT	H57	4 ³ / ₁₆ "	10 ⁵ / ₃₂ "	2 ³ / ₃₂ "	9 ¹ / ₁₆ "	1 ²⁷ / ₃₂ "	5 ⁵ / ₁₆ "	3 ¹⁷ / ₃₂ "	3 ³ / ₃₂ "	3 ³ / ₄ "
2½"	2½" NPT	H67	5 ¹ / ₁₆ "	11 ¹³ / ₁₆ "	2 ³ / ₄ "	2 ³ / ₃₂ "	2 ¹ / ₁₆ "	7 ¹ / ₃₂ "	4 ⁹ / ₃₂ "	3 ²⁹ / ₃₂ "	4 ¹ / ₁₆ "
3"	3" NPT	H87	5 ²⁹ / ₃₂ "	12 ²⁷ / ₃₂ "	2 ² / ₃₂ "	2 ³ / ₃₂ "	3"	7 ¹³ / ₃₂ "	4 ²³ / ₃₂ "	4 ¹⁷ / ₃₂ "	4 ²³ / ₃₂ "
4"	4" ANSI	H107	7 ⁷ / ₈ "	15 ¹ / ₂ "	3"	2 ⁵ / ₃₂ "	3 ¹⁵ / ₁₆ "	8 ⁵ / ₃₂ "	5 ² / ₃₂ "	5 ¹ / ₃₂ "	6 ¹ / ₁₆ "
5"	5" ANSI	H127	11 ¹ / ₂ "	18 ⁵ / ₁₆ "	3 ¹ / ₃₂ "	1 ⁵ / ₁₆ "	4 ¹⁵ / ₁₆ "	10 ¹³ / ₁₆ "	7 ¹⁵ / ₃₂ "	6 ⁷ / ₃₂ "	8 ² / ₃₂ "

Duoflow Rotating Unions

Size	B Port	O Port	Duoflow E-R-S	A	D	E	F	G	J	L	M	M ₁	M ₂	N
¾"	¾" NPT	½" NPT	H20	2 ²³ / ₃₂ "	7 ¹ / ₁₆ "	1 ¹ / ₁₆ "	1 ⁵ / ₃₂ "	2 ³ / ₃₂ "	3 ³ / ₄ "	2 ⁵ / ₁₆ "	1 ²⁵ / ₃₂ "	1 ³ / ₃₂ "	1 ³ / ₁₆ "	3 ³ / ₈ "
1"	1" NPT	½" NPT	H25	3 ¹ / ₁₆ "	8 ² / ₃₂ "	1 ²⁷ / ₃₂ "	1 ⁵ / ₃₂ "	3 ¹ / ₃₂ "	3 ³ / ₃₂ "	1 ²³ / ₃₂ "	1 ³ / ₃₂ "	2 ³ / ₈ "	1 ³ / ₁₆ "	4 ³ / ₃₂ "
1¼"	1" NPT	¾" NPT	H32	3 ¹ / ₁₆ "	8"	1 ¹⁵ / ₁₆ "	9 ¹ / ₁₆ "	1 ¹ / ₄ "	4 ¹ / ₁₆ "	1 ³ / ₄ "	2 ¹ / ₁₆ "	2 ¹ / ₁₆ "	2 ¹ / ₁₆ "	2 ³ / ₈ "
1½"	1¼" NPT	1" NPT	H40	3 ²⁹ / ₃₂ "	9 ² / ₃₂ "	2 ¹³ / ₃₂ "	9 ¹ / ₁₆ "	1 ¹ / ₂ "	5 ³ / ₈ "	2"	2 ¹ / ₄ "	2 ¹⁵ / ₁₆ "	2 ¹⁵ / ₁₆ "	2 ¹³ / ₁₆ "
2"	1½" NPT	1¼" NPT	H57	4 ³ / ₁₆ "	11 ¹⁵ / ₁₆ "	2 ¹³ / ₃₂ "	9 ¹ / ₁₆ "	1 ²⁷ / ₃₂ "	5 ⁵ / ₁₆ "	3 ¹⁷ / ₃₂ "	3 ³ / ₃₂ "	3 ³ / ₄ "	3 ³ / ₄ "	3 ¹³ / ₁₆ "
2½"	2" NPT	1½" NPT	H67	5 ¹ / ₁₆ "	14 ¹ / ₈ "	2 ³ / ₄ "	2 ³ / ₃₂ "	2 ¹ / ₁₆ "	7 ¹ / ₃₂ "	4 ⁹ / ₃₂ "	3 ²⁹ / ₃₂ "	4 ¹ / ₁₆ "	4 ¹ / ₁₆ "	4 ²⁹ / ₃₂ "
3"	2½" NPT	2" NPT	H87	5 ²⁹ / ₃₂ "	15 ¹⁹ / ₃₂ "	2 ² / ₃₂ "	2 ³ / ₃₂ "	3"	7 ¹³ / ₃₂ "	4 ²³ / ₃₂ "	4 ¹⁷ / ₃₂ "	4 ²³ / ₃₂ "	4 ²³ / ₃₂ "	5 ³ / ₄ "
4"	3" ANSI	2½" ANSI	H107	7 ⁷ / ₈ "	22 ⁵ / ₃₂ "	3"	2 ⁵ / ₃₂ "	3 ¹⁵ / ₁₆ "	8 ² / ₃₂ "	5 ² / ₃₂ "	5 ¹³ / ₃₂ "	6 ¹ / ₁₆ "	6 ¹ / ₁₆ "	9 ⁷ / ₈ "
	2½" ANSI	2½" ANSI	H107*	7 ⁷ / ₈ "	22 ⁵ / ₃₂ "	3"	2 ⁵ / ₃₂ "	3 ¹⁵ / ₁₆ "	8 ² / ₃₂ "	5 ² / ₃₂ "	5 ¹³ / ₃₂ "	6 ¹ / ₁₆ "	6 ¹ / ₁₆ "	9 ⁷ / ₈ "
5"	4" ANSI	2½" ANSI	H127	11 ¹ / ₂ "	24 ⁵ / ₁₆ "	3 ¹ / ₃₂ "	1 ⁵ / ₁₆ "	4 ¹⁵ / ₁₆ "	10 ¹³ / ₁₆ "	7 ¹⁵ / ₃₂ "	6 ⁷ / ₃₂ "	8 ² / ₃₂ "	8 ² / ₃₂ "	9 ²⁷ / ₃₂ "
	3" ANSI	3" ANSI	H127*	11 ¹ / ₂ "	24 ¹⁹ / ₃₂ "	3 ¹ / ₃₂ "	1 ⁵ / ₁₆ "	4 ¹⁵ / ₁₆ "	10 ¹³ / ₁₆ "	7 ¹⁵ / ₃₂ "	6 ⁷ / ₃₂ "	8 ² / ₃₂ "	8 ² / ₃₂ "	9 ²⁷ / ₃₂ "

*Hot Oil Design

Duoflow Rotating Union Models Size H20 – H40

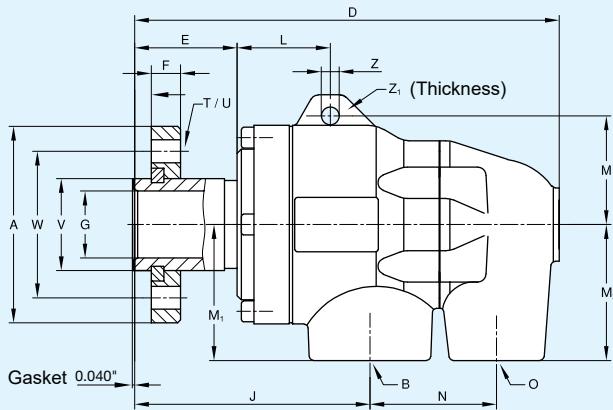

Models Size H57 – H87

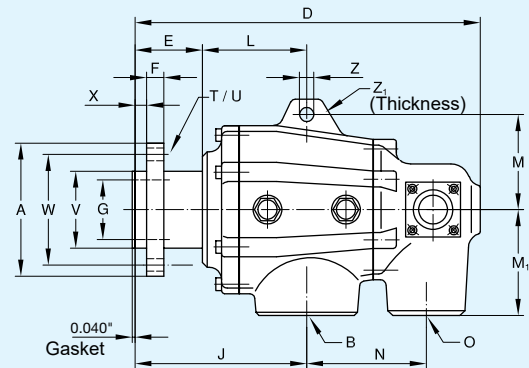

Models Size H107 and H127

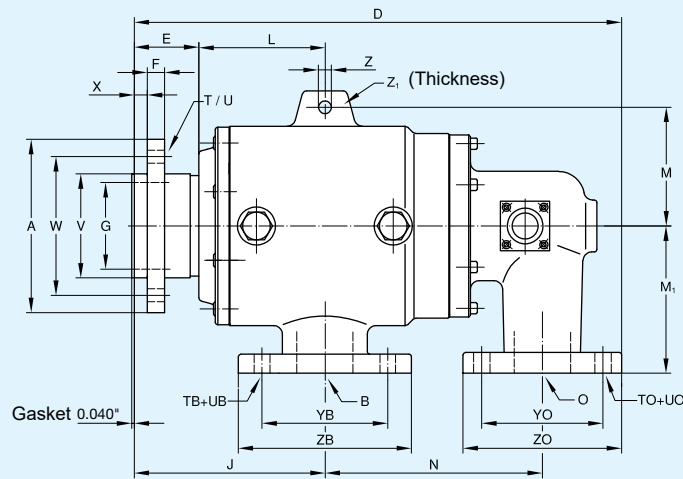

T	U	TB	UB	V*	W	X	YB	ZB	Z	Z ₁	Size
4 x 90°	3/8"	-	-	1.181	1 3/32"	1/4"	-	-	9/32"	5/16"	3/4"
4 x 90°	3/8"	-	-	1.417	2 3/8"	9/32"	-	-	9/32"	7/16"	1"
4 x 90°	7/16"	-	-	1.732	2 3/4"	5/16"	-	-	1 1/32"	5/16"	1 1/4"
4 x 90°	7/16"	-	-	2.047	3 1/16"	13/32"	-	-	7/16"	13/32"	1 1/2"
4 x 90°	7/16"	-	-	2.559	3 3/4"	1 3/32"	-	-	1/2"	19/32"	2"
4 x 90°	1/2"	-	-	3.149	4 17/32"	15/32"	-	-	19/32"	25/32"	2 1/2"
4 x 90°	1/2"	-	-	3.740	4 15/16"	15/32"	-	-	19/32"	1"	3"
6 x 60°	19/32"	8 x 45°	3/4"	4.724	6 5/16"	19/32"	7 1/2"	8 1/32"	19/32"	1"	4"
6 x 60°	23/32"	8 x 45°	7/8"	6.299	8 27/32"	19/32"	8 1/2"	9 7/32"	19/32"	1"	5"

T	U	TB	UB	TO	UO	V*	W	X	YB	ZB	YO	ZO	Z	Z ₁	Size
4 x 90°	3/8"	-	-	-	-	1.181	1 3/32"	1/4"	-	-	-	-	9/32"	5/16"	3/4"
4 x 90°	3/8"	-	-	-	-	1.417	2 3/8"	9/32"	-	-	-	-	9/32"	7/16"	1"
4 x 90°	7/16"	-	-	-	-	1.732	2 3/4"	5/16"	-	-	-	-	1 1/32"	5/16"	1 1/4"
4 x 90°	7/16"	-	-	-	-	2.047	3 1/16"	13/32"	-	-	-	-	7/16"	13/32"	1 1/2"
4 x 90°	7/16"	-	-	-	-	2.559	3 3/4"	1 3/32"	-	-	-	-	1/2"	19/32"	2"
4 x 90°	1/2"	-	-	-	-	3.149	4 17/32"	15/32"	-	-	-	-	19/32"	25/32"	2 1/2"
4 x 90°	1/2"	-	-	-	-	3.740	4 15/16"	15/32"	-	-	-	-	19/32"	1"	3"
6 x 60°	19/32"	4 x 90°	3/4"	4 x 90°	3/4"	4.724	6 5/16"	19/32"	6"	7 7/8"	5 1/2"	7 7/32"	19/32"	1"	4"
6 x 60°	19/32"	4 x 90°	3/4"	4 x 90°	3/4"	4.724	6 5/16"	19/32"	5 1/2"	7 9/32"	5 1/2"	7 7/32"	19/32"	1"	4"
6 x 60°	23/32"	8 x 45°	3/4"	4 x 90°	3/4"	6.299	8 27/32"	19/32"	7 1/2"	8 21/32"	5 1/2"	7 7/32"	19/32"	1"	5"
6 x 60°	23/32"	4 x 90°	3/4"	4 x 90°	3/4"	6.299	8 27/32"	19/32"	6"	7 7/8"	6"	7 7/8"	19/32"	1"	5"

*Tolerance +.000 to -.003 depending on size.

Duoflow Central Pipe Specifications

Rotating Central Pipe

R For rotating siphon (steam inlet pipe); the inner pipe is connected by means of a threaded bushing that screws into the rotor.

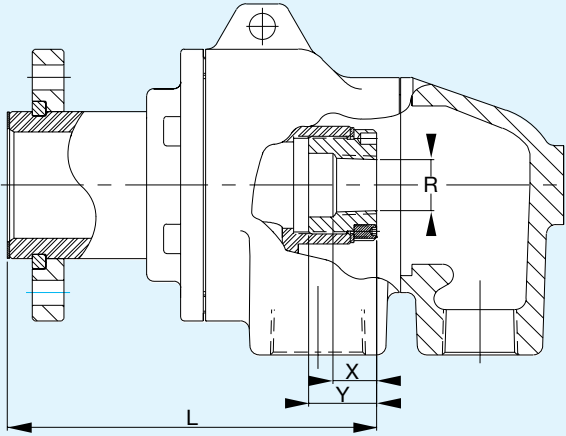

Rotating Central Pipe Axial Movement

E For a rotating siphon capable of axial movement; a sliding connection is made between the bushing and the central pipe to allow for the thermal expansion of the central pipe.

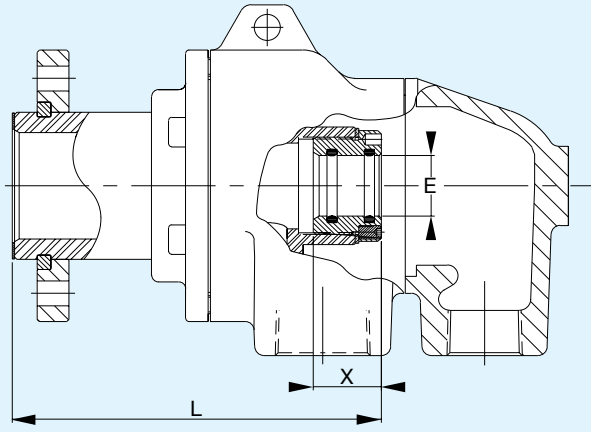

Model	L	X	Y	Optional Pipe Sizes "R"
H20	4 ¹³ / ₃₂ "	1 ⁹ / ₃₂ "	2 ²⁵ / ₃₂ "	1/8" - 1/4" NPT
H25	5 ¹ / ₄ "	1 ⁹ / ₃₂ "	2 ²⁵ / ₃₂ "	1/4" - 3/8" NPT
H32	5 ²⁵ / ₃₂ "	2 ⁵ / ₃₂ "	1"	3/8" - 1/2" NPT
H40	6 ⁷ / ₈ "	1"	1 ³ / ₁₆ "	1/2" - 1" NPT
H57	9 ³ / ₁₆ "	1"	1 ³ / ₈ "	1/2" - 1 ¹ / ₄ " NPT
H67	10 ³ / ₄ "	1"	1 ³ / ₈ "	1/2" - 1 ¹ / ₂ " NPT
H87	11 ¹³ / ₁₆ "	1"	1 ¹ / ₈ "	1" - 2" NPT
H107	14 ³ / ₄ "	1 ²⁵ / ₃₂ "	2 ³ / ₈ "	1" - 3" NPT
H127	18 ¹ / ₈ "	1 ²⁵ / ₃₂ "	2 ³ / ₈ "	1 ¹ / ₄ " - 4" NPT

Model	L	X	Optional Pipe Sizes "E"
H20	4 ¹³ / ₃₂ "	2 ²⁵ / ₃₂ "	1/8" - 1/4"
H25	5 ¹ / ₄ "	2 ²⁵ / ₃₂ "	1/4" - 3/8"
H32	5 ²⁵ / ₃₂ "	1"	3/8" - 1/2"
H40	6 ⁷ / ₈ "	1 ³ / ₁₆ "	1/2" - 1"
H57	9 ³ / ₁₆ "	1 ³ / ₈ "	1/2" - 1 ¹ / ₄ "
H67	10 ³ / ₄ "	1 ³ / ₈ "	1/2" - 1 ¹ / ₂ "
H87	11 ¹³ / ₁₆ "	1 ¹ / ₈ "	1" - 2"
H107	14 ³ / ₄ "	2 ³ / ₈ "	1" - 3"
H127	18 ¹ / ₈ "	2 ³ / ₈ "	1 ¹ / ₄ " - 4"

Stationary Central Pipe

S For fixed siphons; the pipe is connected by means of a threaded bushing that screws into the end cap.

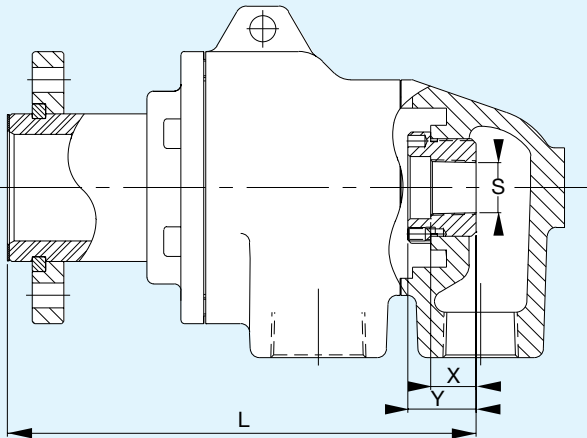

Stationary Central Pipe

SK For stationary fixed siphons; the central pipe is supported in the end cap and connected by means of an external bolt to the end cap.

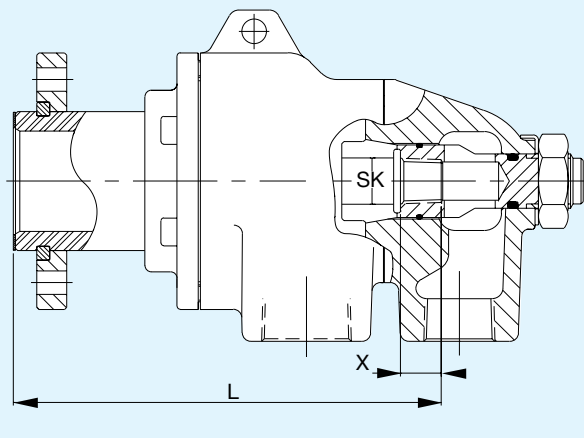

Model	L	X	Y	Optional Pipe Sizes "S"
H20	5 ¹³ / ₃₂ "	7/16"	5/8"	1/8" - 1/4" NPT
H25	6 ³ / ₁₆ "	7/16"	2 ²⁵ / ₃₂ "	1/4" - 3/8" NPT
H32	6 ²⁵ / ₃₂ "	1 ⁹ / ₃₂ "	1"	3/8" - 1/2" NPT
H40	8 ¹ / ₈ "	2 ²⁵ / ₃₂ "	1 ⁵ / ₁₆ "	1/2" - 1" NPT
H57	9 ³ / ₈ "	1"	1 ⁹ / ₁₆ "	1/2" - 1 ¹ / ₄ " NPT
H67	11 ¹⁵ / ₁₆ "	1 ³ / ₈ "	1 ⁹ / ₁₆ "	1/2" - 1 ¹ / ₂ " NPT
H87	13"	1 ³ / ₈ "	1 ³ / ₁₆ "	1" - 2" NPT
H107	-	-	-	-
H127	-	-	-	-

Model	L	X	Optional Pipe Sizes "SK"
H57	8 ³ / ₃₂ "	1 ¹ / ₁₆ "	1/2" - 3/4"
H67	10 ³ / ₈ "	1 ¹ / ₁₆ "	3/4" - 1"
H87	11 ¹⁵ / ₃₂ "	1 ¹ / ₁₆ "	1" - 1 ¹ / ₄ "
H107	14 ³ / ₄ "	2 ³ / ₈ "	1" - 1 ¹ / ₄ "
H127	18 ¹ / ₈ "	2 ³ / ₈ "	1 ¹ / ₄ " - 1 ¹ / ₂ "

Adjustable Siphons Available
Consult DEUBLIN

DEUBLIN

1/8" to 1/2" Air-Hydraulic Unions

- Monoflow design
- Self-supported rotating union
- Radial housing connection
- Balanced mechanical seal
- Seal combinations:
Carbon Graphite/Hardened Tool Steel or
Carbon Graphite/Silicon Carbide
- Felt oiler in seal cavity for air service
- Oiler for relubrication (3 - 5 drops/month)
- Low torque
- Weight-optimized design
- Aluminum housing
- Bearings lubricated for life



Operating Data

Maximum Air Pressure	150 PSI	10 bar
Maximum Vacuum	28" Hg	6.7 kPa
Maximum Hydraulic Pressure		
Model 1005	1,000 PSI	70 bar
Model 1102	1,000 PSI	70 bar
Model 1115	500 PSI	34 bar
Model 1205	750 PSI	50 bar
Model 2200*	1,000 PSI	70 bar
Maximum Speed NPT Threads	1,500 RPM	1,500/min
Maximum Speed Straight Threads	3,500 RPM	3,500/min
Maximum Temperature	250°F	120°C

* Union is designed for continuous operation at either maximum speed or maximum pressure. If operating conditions are close to maximum pressure and speed simultaneously, consult **DEUBLIN**.

See next page for dimensional data.

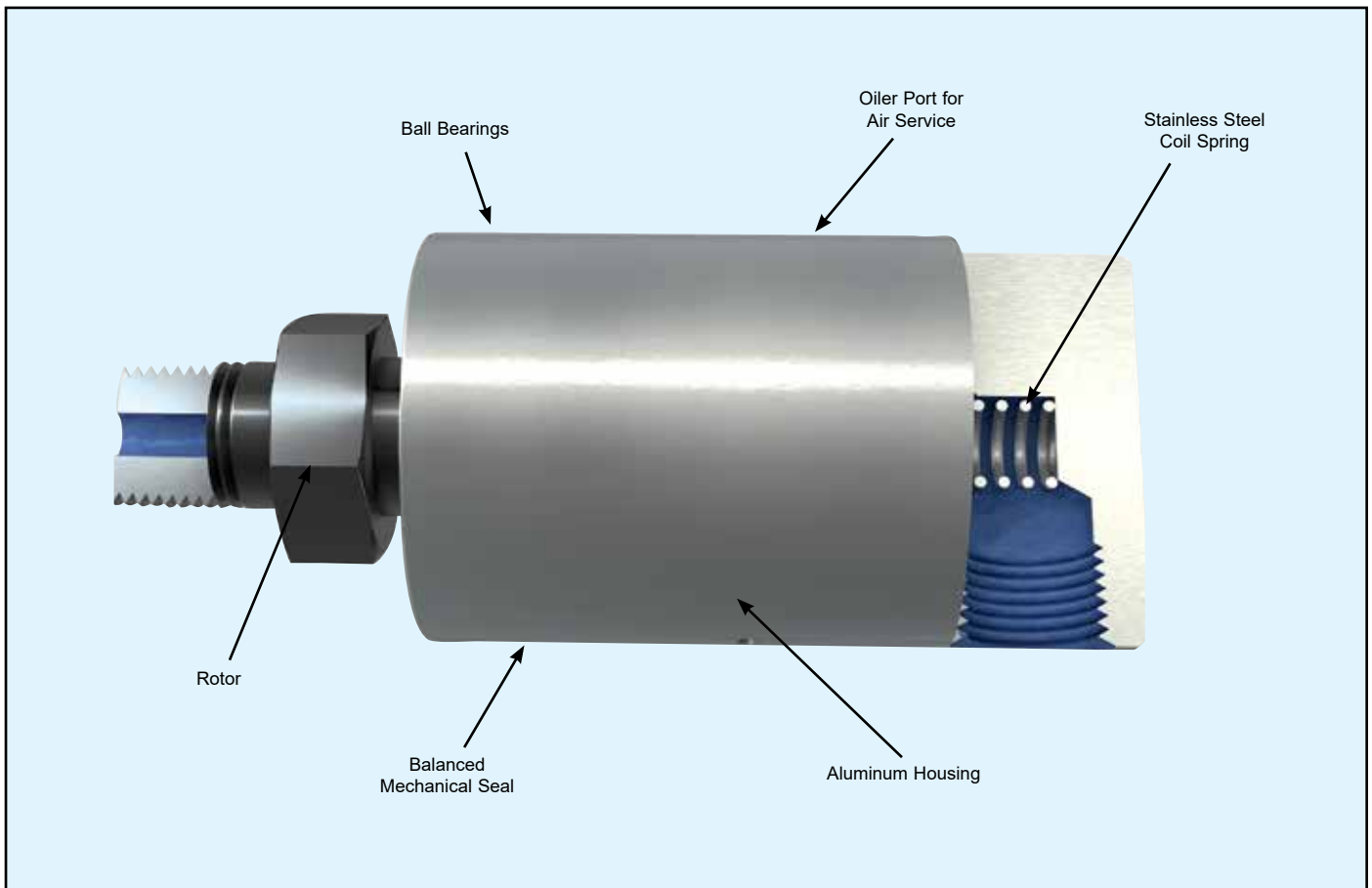

Monoflow Rotating Union

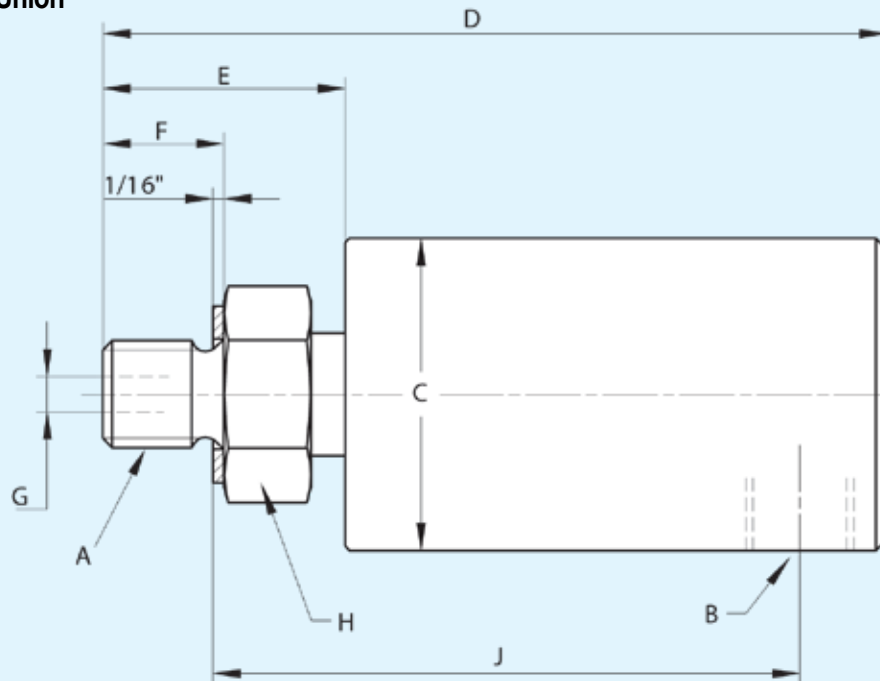

B Port NPT	Ordering No.	A Rotor Thread		C Dia.	D	E	F	G Rotor Hole	H* Across Flats	J Lock-up	Shpg. Wt.
	Model										
1/8"	1005-020-019	3/8"-24 UNF	RH	1 1/8"	2 13/16"	7/8"	1/2"	1/8"	17	2 1/16"	1/2#
	1005-020-039	3/8"-24 UNF	LH								
	1005-020-038	1/8" NPT	RH								
	1005-020-037	M10x1	RH								
	1005-020-049	G 3/8" (BSP)	RH								
1/4"	1102-070-029	5/8"-18 UNF	RH	1 5/8"	3 3/16"	1 1/8"	5/8"	1/4"	22	2 1/4"	1#
	1102-070-079	5/8"-18 UNF	LH								
	1102-070-081	1/4" NPT	RH								
	1102-070-082	1/4" NPT	LH								
	1102-070-103	G 1/2" (BSP)	RH								
	1102-070-104	G 1/2" (BSP)	LH								
3/8"	1115-000-001	5/8"-18 UNF	RH	1 23/32"	3 15/16"	1 1/16"	5/8"	3/8"	24	2 27/32"	1 1/2#
	1115-000-017	5/8"-18 UNF	LH								
	1115-000-002	3/8" NPT	RH								
	1115-000-018	1/4" NPT	RH								
	1115-000-205	G 3/8" (BSP)	RH								
	1115-000-200	M16x2	RH								
1/2"	1205-000-003	1/2" NPT	RH	2 1/4"	4 9/16"	1 1/16"	7/8"	1/2"	30	3 1/2"	1 1/2#
	1205-000-004	1/2" NPT	LH								
	1205-000-019	3/4" NPT	RH								
	1205-000-020	3/4" NPT	LH								
	1205-000-039	3/4"-16 UNF	RH								
	1205-000-025	3/4"-16 UNF	LH								
	1205-000-001	1"-14 UNS	RH								
	1205-000-002	1"-14 UNS	LH								
	1205-000-012	G 1/2" (BSP)	RH								
	1205-000-013	G 1/2" (BSP)	LH								
	1205-000-021	G 3/4" (BSP)	RH								
	1205-000-022	G 3/4" (BSP)	LH								
1/2"	2200-000-096	1/2" NPT	RH	2 7/8"	4 15/16"	1 1/16"	7/8"	1/2"	32	3 3/4"	3#
	2200-000-097	1/2" NPT	LH								
	2200-000-098	3/4" NPT	RH								
	2200-000-099	3/4" NPT	LH								
	2200-000-003	1"-14 UNS	RH								
	2200-000-027	1"-14 UNS	LH								
	2200-000-102	G 3/4" (BSP)	RH								
2200-000-103	G 3/4" (BSP)	LH									

*Metric

DEUBLIN

3/4" to 1 1/2" Air-Hydraulic Unions

- Monoflow design
- Self-supported rotating union
- Radial housing connection
- Balanced mechanical seal
- Seal combinations:
Carbon Graphite/Hardened Tool Steel or
Carbon Graphite/Ceramic
- Felt oiler in seal cavity for air service
- Oiler for relubrication (3 - 5 drops/month)
- Low torque
- Aluminum housing
- Stainless steel or steel rotor (respective of model)
- Lubrication Guide page 55



Operating Data

Maximum Air Pressure	150 PSI	10 bar
Maximum Vacuum	28" Hg	6.7 kPa
Maximum Hydraulic Pressure		
Model 250-094	1,000 PSI	70 bar
Model 355-021	1,000 PSI	70 bar
Model 452-000	750 PSI	50 bar
Maximum Speed NPT Threads	1,500 RPM	1,500/min
Maximum Speed Straight Threads		
Model 250-094	3,500 RPM	3,500/min
Model 355-021	3,000 RPM	3,000/min
Model 452-000	2,500 RPM	2,500/min
Maximum Temperature	250°F	120°C

Union is designed for continuous operation at either maximum speed or maximum pressure. If operating conditions are close to maximum pressure and speed simultaneously, consult **DEUBLIN**.

To indicate union with additional "K" port with
 1/2" NPT: Order Number 250-979-RTR
 3/8" NPT: Order Number 355-305-RTR
 1/4" NPT: Order Number 452-001-RTR

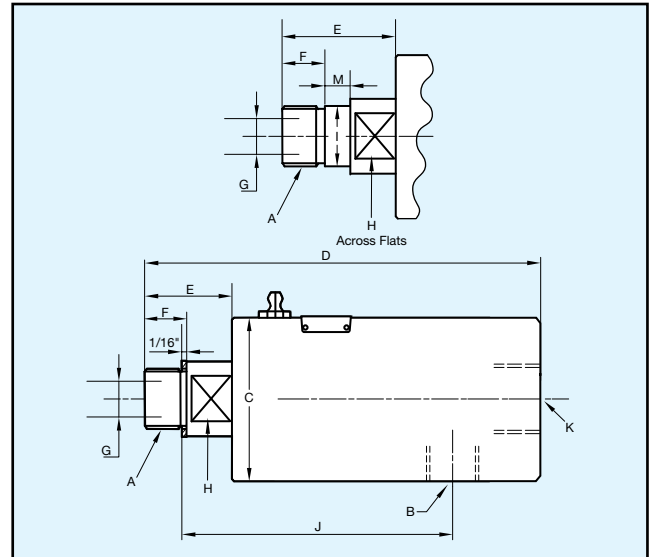

B Port NPT	Ordering No. Model	A Rotor Thread	C	D	E	F	G Rotor Hole	H* Across Flats	I Pilot Dia.	J Lock-up	M	Shpg. Wt.
3/4"	250-094-020	3/4" NPT RH	2 7/8"	5 1/8"	1 1/16"	7/8"	1 1/16"	32	-	4 1/16"	-	3 1/2#
	250-094-021	3/4" NPT LH	2 7/8"	5 1/8"	1 1/16"	7/8"	1 1/16"	32	-	4 1/16"	-	3 1/2#
	250-094-002	1"-14 UNS RH	2 7/8"	5"	1 5/16"	3/4"	2 1/32"	32	-	3 1/16"	-	3 1/2#
	250-094-027	1"-14 UNS LH	2 7/8"	5"	1 5/16"	3/4"	2 1/32"	32	-	3 1/16"	-	3 1/2#
	250-094-016	1"-14 UNS (PLT) RH	2 7/8"	5 1/8"	2 1/8"	3/4"	5/8"	41	1.2480"	4"	1/2"	3 1/2#
	250-094-017	1"-14 UNS (PLT) LH	2 7/8"	5 1/8"	2 1/8"	3/4"	5/8"	41	1.2478"	4"	1/2"	3 1/2#
	250-094-284	G 3/4" (BSP) RH	73	128	34	19	17.5	36	-	94	-	1.6 Kg
	250-094-285	G 3/4" (BSP) LH	73	128	34	19	17.5	36	-	94	-	1.6 Kg
	250-094-012	M22x1.5 (PLT) RH	73	122	28	14	14.3	36	26.992	87.5	3	1.6 Kg
250-094-013	M22x1.5 (PLT) LH	73	122	28	14	14.3	36	26.979	87.5	3	1.6 Kg	
1"	355-021-002	1" NPT RH	3 1/4"	6 1/16"	1 15/16"	1 1/8"	1"	36	-	4 1/16"	-	4 1/2#
	355-021-003	1" NPT LH	3 1/4"	6 1/16"	1 15/16"	1 1/8"	1"	36	-	4 1/16"	-	4 1/2#
	355-021-019	1 1/2"-12 UNF RH	3 1/4"	6 3/16"	1 15/16"	1 1/8"	1"	36	-	4 1/4"	-	4 1/2#
	355-021-074	1 1/2"-12 UNF LH	3 1/4"	6 3/16"	1 15/16"	1 1/8"	1"	36	-	4 1/4"	-	4 1/2#
	355-021-016	1 1/2"-12 UNF (PLT) RH	3 1/4"	6 9/16"	2 5/16"	1"	1"	36	1.5610"	4 3/16"	1/2"	4 1/2#
	355-021-017	1 1/2"-12 UNF (PLT) LH	3 1/4"	6 9/16"	2 5/16"	1"	1"	36	1.5605"	4 3/16"	1/2"	4 1/2#
	355-021-222	G1" (BSP) RH	82.6	150	42	21	22.2	38	-	108	-	2.1 Kg
	355-021-223	G1" (BSP) LH	82.6	150	42	21	22.2	38	-	108	-	2.1 Kg
1 1/2"	452-000-001	1 1/2" NPT RH	4 1/4"	7 1/16"	2 1/8"	1 3/16"	1 1/2"	55	-	5 1/16"	-	9.5#
	452-000-002	1 1/2" NPT LH	4 1/4"	7 1/16"	2 1/8"	1 3/16"	1 1/2"	55	-	5 1/16"	-	9.5#
	452-000-395	2"-12 UN RH	4 1/4"	8 1/16"	2 3/16"	1 1/8"	1 1/2"	55	-	5 5/16"	-	9.5#
	452-000-396	2"-12 UN LH	4 1/4"	8 1/16"	2 3/16"	1 1/8"	1 1/2"	55	-	5 5/16"	-	9.5#
	452-000-029	1 3/4"-12 UN RH	4 1/4"	8 7/16"	3 3/16"	7/8"	1 1/4"	55	-	6 1/4"	-	9.5#
	452-000-109	1 3/4"-12 UN LH	4 1/4"	8 7/16"	3 3/16"	7/8"	1 1/4"	55	-	6 1/4"	-	9.5#
	452-000-198	G1 1/2" (BSP) RH	108	205	72	29	35	55	-	143	-	4.5 Kg
452-000-199	G1 1/2" (BSP) LH	108	205	72	29	35	55	-	143	-	4.5 Kg	

*Metric

Deublin In-The-Shaft Mounted Unions

Model 1005-000-038 $\frac{1}{8}$ " Capacity—for Air or Hyd. Oil

Available with 1005 rotors shown on page 32. To meet the specifications of engineering designs requiring minimum overhang. Deublin can provide unions which can be mounted within the shaft. With these models, the only extensions beyond the end of the shaft are the supply line connections.

Operating Data		
Maximum Air Pressure	150 PSI	10 bar
Maximum Hydraulic Pressure*	1,000 PSI	70 bar
Maximum Speed*	3,500 RPM	3,500/min
Maximum Temperature	250°F	120°C

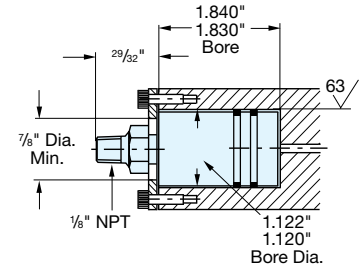

Model 1102-025-081 $\frac{1}{4}$ " Capacity—for Air or Hyd. Oil

Available with 1102 rotors shown on page 32.
Also available with hub mount for CTIS.
See page 52.

Operating Data		
Maximum Air Pressure	150 PSI	10 bar
Maximum Hydraulic Pressure*	1,000 PSI	70 bar
Maximum Speed*	3,500 RPM	3,500/min
Maximum Temperature	250°F	120°C

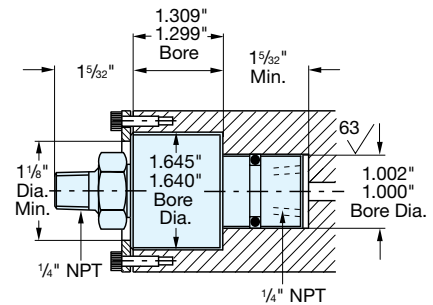

Model 1115-130-002 $\frac{3}{8}$ " Capacity—for Air or Hyd. Oil

Available with 1115 rotors shown on page 32.

Operating Data		
Maximum Air Pressure	150 PSI	10 bar
Maximum Hydraulic Pressure	500 PSI	35 bar
Maximum Speed	3,500 RPM	3,500/min
Maximum Temperature	250°F	120°C

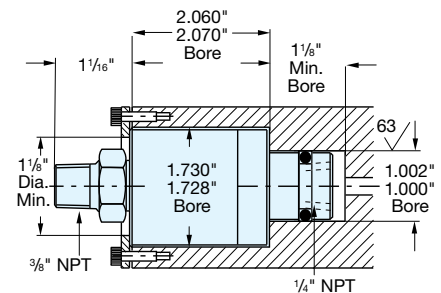

Model 1116-319-248 $\frac{3}{8}$ " Capacity—for Hydraulic Oil

This model contains E.L.S. seals of silicon carbide to silicon carbide for long life on abrasive applications.
Do not run dry.

Operating Data		
Maximum Hydraulic Pressure*	1,000 PSI	70 bar
Maximum Speed*	3,500 RPM	3,500/min
Maximum Temperature	250°F	120°C

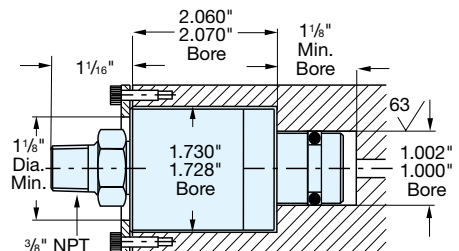

* Union is designed for continuous operation at either maximum speed or maximum pressure.
If operating conditions are close to maximum pressure and speed simultaneously, consult **DEUBLIN**.

DEUBLIN

AP Series High Pressure High Speed Unions

- Monoflow design
- Self-supported rotating union
- Seal combination:
Tungsten Carbide/Tungsten Carbide
- Double row ball bearing; lubricated for life
- Vent holes
- Steel housing nickel-plated
- Stainless steel end cap and rotor
- All parts in media contact are stainless steel and corrosion resistant
- Designed for high pressure and high speed



Operating Data

Maximum Hydraulic/Water Pressure*	5,700 PSI	400 bar
Maximum Speed*	1,500 RPM	1,500/min
Maximum Temperature	200°F	90°C

* Operation at maximum pressure combined with maximum speed should be avoided. For optional performance, refer to graph. If operating conditions are marginal, consult **DEUBLIN**.

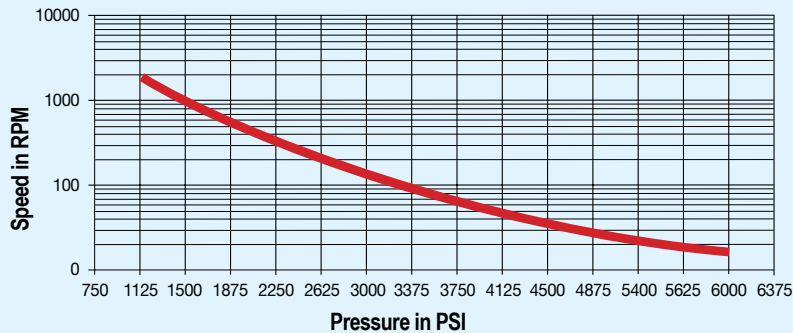
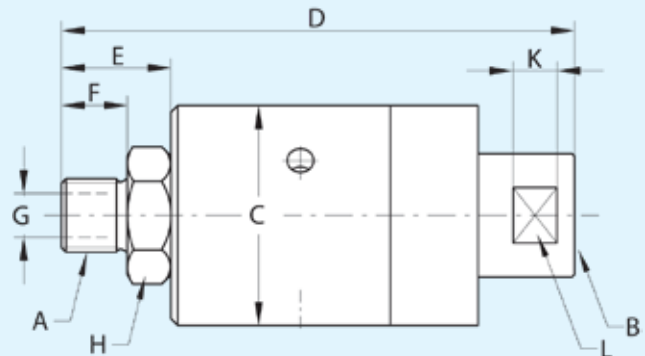

B Inlet Port	Ordering Number	A Rotor Thread	C	D	E	F	G Rotor Hole	H* Across Flats	K	L Across Flats	Shpg. Wt.
1/4" NPT	AP8-011-214	1/4" NPT RH	1 3/32"	4 19/32"	1"	19/32"	9/32"	27	13/32"	1"	1.5#
	AP8-011-215	1/4" NPT LH									
G 1/4" (BSP)	AP8-010-210	G 1/4" (BSP) RH	50	117	25	15	7	27	10	25	.7 Kg
	AP8-010-211	G 1/4" (BSP) LH									
3/8" NPT	AP10-011-214	3/8" NPT RH	1 3/32"	4 19/32"	1"	19/32"	13/32"	27	13/32"	1"	1.5#
	AP10-011-215	3/8" NPT LH									
G 3/8" (BSP)	AP10-010-210	G 3/8" (BSP) RH	50	117	25	15	10	27	10	25	.7 Kg
	AP10-010-211	G 3/8" (BSP) LH									
1/2" NPT	AP12-011-214	1/2" NPT RH	1 3/32"	4 13/16"	1 1/16"	25/32"	15/32"	27	13/32"	1"	2#
	AP12-011-215	1/2" NPT LH									
G 1/2" (BSP)	AP12-010-210	G 1/2" (BSP) RH	50	122	30	20	12	27	10	25	1 Kg
	AP12-010-211	G 1/2" (BSP) LH									

*Metric

DEUBLIN

D Series High Pressure Swivel Low Speed Rotating Unions

- Monoflow design
- For hydraulic oil and water
- For swivel applications and high pressure media
- Steel housing and end cap
- Stainless steel rotor
- Self-supported rotating union
- Can be adapted for other media



Operating Data

Maximum Hydraulic/Water Pressure	6,400 PSI	450 bar
Maximum Speed	20 RPM	20/min
Maximum Temperature	250°F	120°C

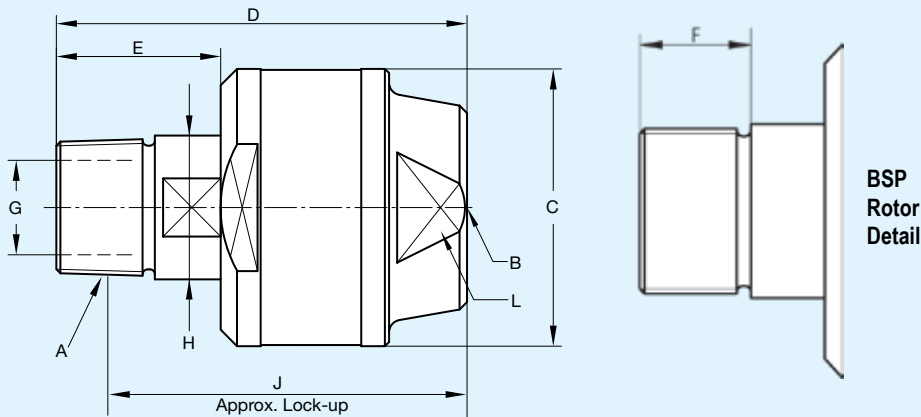

B Inlet Port	Ordering Number	A Rotor Connections	C	D	E	F	G Rotor Hole	H* Across Flats	J Lock-up	L Across Flats	Shpg. Wt.
1/4" NPT	D8-004-214	1/4" NPT RH	1 1/16"	2 11/16"	1"	19/32"	9/32"	12	2 5/16"	15/16"	3/4#
	D8-004-215	1/4" NPT LH									
G 1/4" (BSP)	D8-003-210	G 1/4" (BSP) RH	40	68	25	15	7	12	53	24	.3 Kg
	D8-003-211	G 1/4" (BSP) LH									
3/8" NPT	D10-004-214	3/8" NPT RH	1 3/4"	2 3/4"	1"	25/32"	13/32"	14	2 3/8"	1 3/32"	7/8#
	D10-004-215	3/8" NPT LH									
G 3/8" (BSP)	D10-003-210	G 3/8" (BSP) RH	44	70	25	15	10	14	55	28	.4 Kg
	D10-003-211	G 3/8" (BSP) LH									
1/2" NPT	D12-004-214	1/2" NPT RH	2 7/32"	3 1/2"	1 1/4"	25/32"	15/32"	22	2 23/32"	1 1/2"	1 3/4#
	D12-004-215	1/2" NPT LH									
G 1/2" (BSP)	D12-003-210	G 1/2" (BSP) RH	56	82	32	20	12	22	62	38	.8 Kg
	D12-003-211	G 1/2" (BSP) LH									
3/4" NPT	D20-004-214	3/4" NPT RH	2 7/16"	3 17/32"	1 11/32"	25/32"	23/32"	27	3"	1 21/32"	2 1/4#
	D20-004-215	3/4" NPT LH									
G 3/4" (BSP)	D20-003-210	G 3/4" (BSP) RH	62	90	34	20	18	27	70	42	1.0 Kg
	D20-003-211	G 3/4" (BSP) LH									
1" NPT	D25-004-214	1" NPT RH	2 11/16"	3 15/16"	1 19/32"	15/16"	29/32"	32	3 1/4"	1 1/8"	2 3/4#
	D25-004-215	1" NPT LH									
G 1" (BSP)	D25-003-210	G 1" (BSP) RH	68	100	40	24	23	32	76	48	1.3 Kg
	D25-003-211	G 1" (BSP) LH									
1 1/4" NPT	D32-004-214	1 1/4" NPT RH	3 5/8"	4 1/4"	1 11/16"	1"	1 3/16"	42	3 3/16"	2 9/32"	4 1/4#
	D32-004-215	1 1/4" NPT LH									
G 1 1/4" (BSP)	D32-003-210	G 1 1/4" (BSP) RH	80	108	43	25	30	42	83	58	1.9 Kg
	D32-003-211	G 1 1/4" (BSP) LH									
1 1/2" NPT	D40-004-214	1 1/2" NPT RH	3 5/8"	4 15/32"	1 23/32"	1 1/2"	1 1/2"	46	3 13/16"	2 7/16"	6 1/8#
	D40-004-215	1 1/2" NPT LH									
G 1 1/2" (BSP)	D40-003-210	G 1 1/2" (BSP) RH	88	114	44	26	38	46	88	62	3.0 Kg
	D40-003-211	G 1 1/2" (BSP) LH									

*Metric

DEUBLIN

Deu-Plex Air Unions

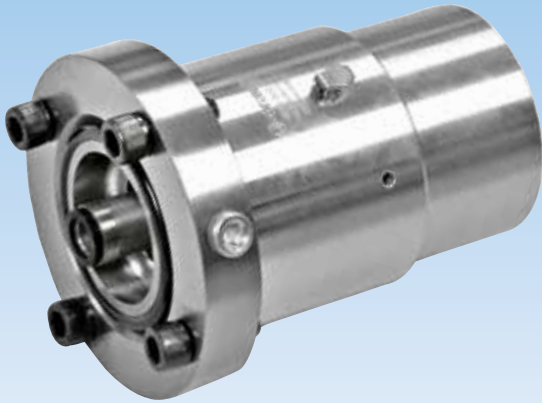

- Duoflow design
- Self-supported rotating union
- Flanged rotor
- Radial housing connections
- Low torque
- Balanced mechanical seals
- Seal combination:
Carbon Graphite/Cast Iron
- Full-media flow
- Aluminum housing
- Cast iron rotor
- Oil cup (3-5 drops/month)

Operating Data

Maximum Air Pressure	150 PSI	10 bar
Maximum Vacuum	28" Hg	6.7 kPa
Maximum Speed	1,500 RPM	1,500/min
Maximum Temperature	250°F	120°C

Only one passage should be pressurized at a time.

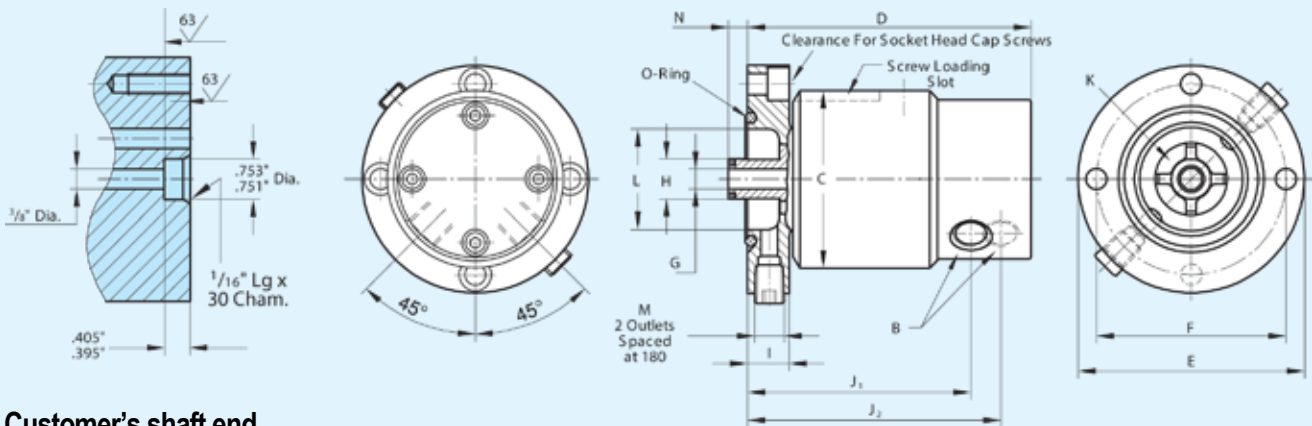
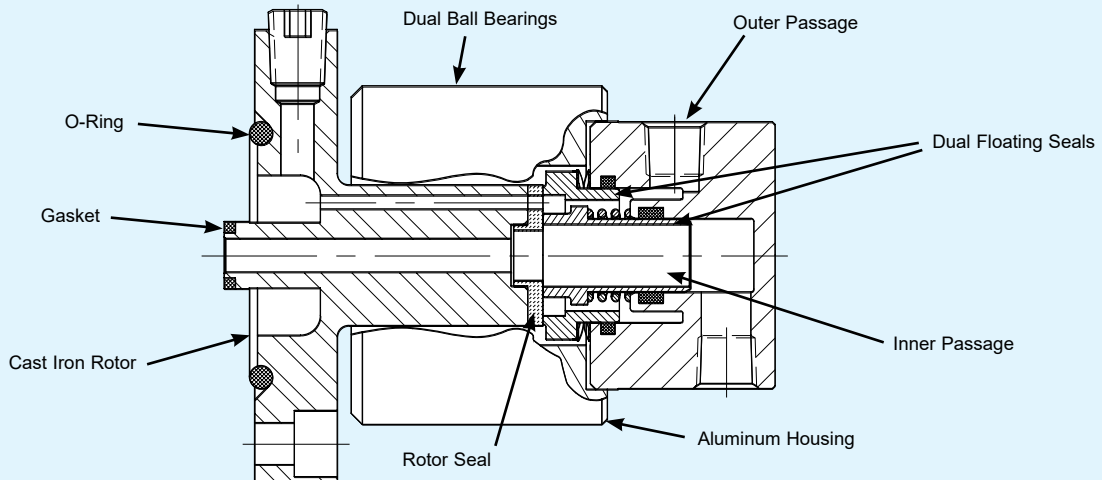

Customer's shaft end

B Port NPT	Ordering No.	C	D	E Pilot	F Bolt Circle	G Area	H	I	J ₁	J ₂	K Area	L	M Tap	N	Screw	Shpg. Wt.
	Model															
(2) x 3/8"	1500-000	3 5/8"	5 1/4"	4.250" 4.249"	3 5/8"	.1105in ²	.750" .748"	3/4"	4 1/8"	4 1/16"	.2304in ²	1 7/8"	1/4" NPT	7/16"	3/8"-16	7#
	1500-250	84	133	107.95 107.92	90.5	71mm ²	19.05 19.00	19	105	119	150mm ²	48	1/4" NPT	11.1	M10	3.2 Kg

DEUBLIN

2620 Series 2-Passage Rotating Unions for Various Media

- Two independent passages for applications such as clamping and unclamping
- Balanced mechanical seals for each passage provide long life and reduced torque even at maximum pressure
- Closed seals provide continuous containment of media
- Dual precision ball bearings for smooth operation
- Labyrinth protection for ball bearings
- Mountings options are compatible with DEUBLIN 2520 or 1579 series unions



Operating Data

Media	See table	
Filtration	ISO 4406 Class 17/15/12, max. 60 micron	
Maximum Speed	7,000 min ⁻¹	7,000 rpm
Maximum Pressure	See table	
Maximum Flow	69 l/min	18.2 gpm (per passage)
Maximum Temperature	160°F	71°C

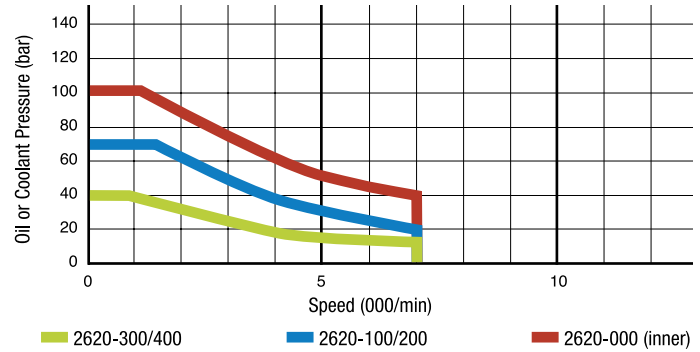

Note: Refer to Page 37 for mounting details.

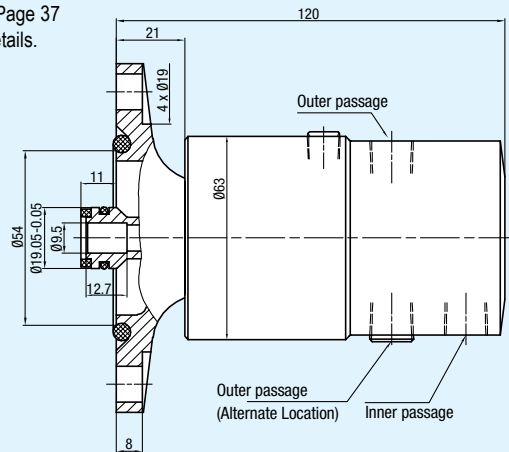

2620-XXX-252 shown

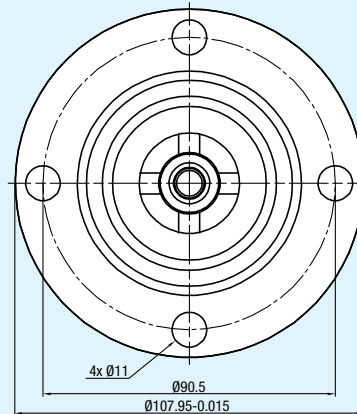

With Ø 108 mm flanged rotor		With Ø 88 mm flanged rotor		With Ø 81 mm flanged rotor		Inner Passage		Outer Passage		Notes	
Ordering Number	Supply Connections	Ordering Number	Supply Connections		Ordering Number	Supply Connections	Media	Max. Pressure {bar}	Media		Max. Pressure {bar}
	Inner and Outer Passage		Inner Passage	Outer Passage							
2620-000-252	1/4 NPT	2620-002-940	G1/4"	G1/4"	2620-000-157	1/4 NPT	Hydraulic oil	100	Hydraulic oil	30	
2620-100-252	1/4 NPT	2620-102-940	G3/8"	G1/8"	2620-100-157	1/4 NPT	Hydraulic oil	70	Air	6	Air seals may be lubricated through oil cup or by using oiled air.
2620-120-252	1/4 NPT	2620-122-940	G3/8"	G1/8"	2620-120-157	1/4 NPT	Hydraulic oil	70	Air	10	
2620-200-252	1/4 NPT	2620-202-940	G3/8"	G1/8"	2620-200-157	1/4 NPT	Coolant	70	Air	6	
2620-220-252	1/4 NPT	2620-222-940	G3/8"	G1/8"	2620-220-157	1/4 NPT	Coolant	70	Air	10	
2620-300-252	1/4 NPT	2620-302-940	G1/4"	G1/4"	2620-300-157	1/4 NPT	Air	6	Hydraulic oil	40	Air seals require no external lubrication.
2620-320-252	1/4 NPT	2620-322-940	G1/4"	G1/4"	2620-320-157	1/4 NPT	Air	10	Hydraulic oil	40	
2620-400-252	1/4 NPT	2620-402-940	G1/4"	G1/4"	2620-400-157	1/4 NPT	Air	6	Coolant	40	
2620-420-252	1/4 NPT	2620-422-940	G1/4"	G1/4"	2620-420-157	1/4 NPT	Air	10	Coolant	40	
2620-500-252	1/4 NPT	2620-502-940	G3/8"	G1/8"	2620-500-157	1/4 NPT	Air	6	Air	6	Consult DEUBLIN regarding maximum speed.
2620-520-252	1/4 NPT	2620-522-940	G3/8"	G1/8"	2620-520-157	1/4 NPT	Air	10	Air	10	

DEUBLIN

2620 Series 2-Passage Rotating Unions for Various Media

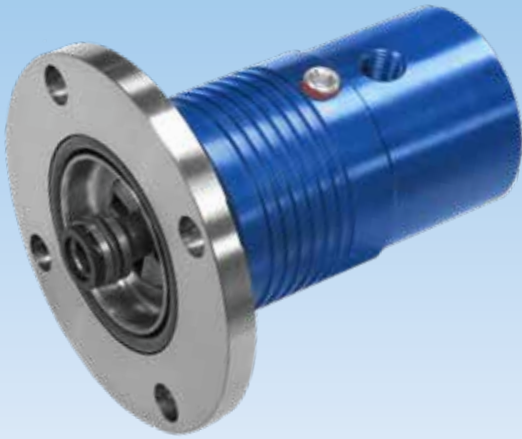

- Two independent passages for applications such as clamping and unclamping, work piece sensing, and cooling
- Balanced mechanical seals for each passage provide long life and reduced torque even at maximum pressure
- Closed seals provide continuous containment of media
- Dual precision ball bearings for smooth operation
- Labyrinth protection for ball bearings
- Mountings options are compatible with DEUBLIN 2520 or 1579 series unions

Operating Data

Media	See table	
Filtration	ISO 4406 Class 17/15/12, max. 60 micron	
Maximum Speed	12,000 min-1	12,000 rpm
Maximum Pressure	See table	
Maximum Flow	69 l/min	18.2 gpm (per passage)
Maximum Temperature	71°C	160°F

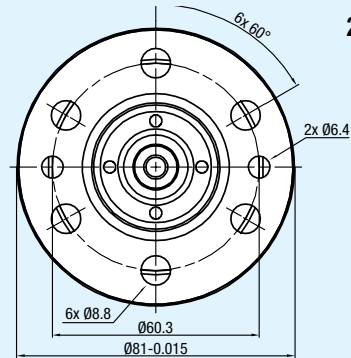
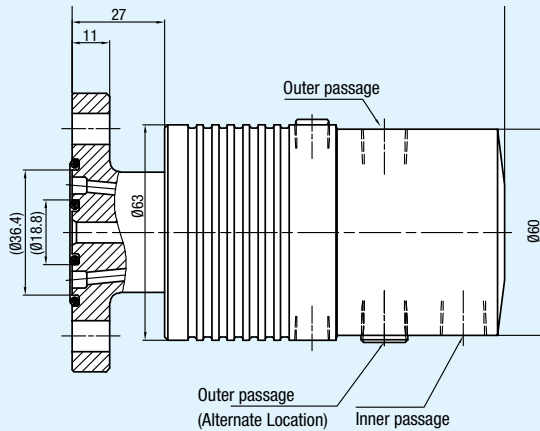
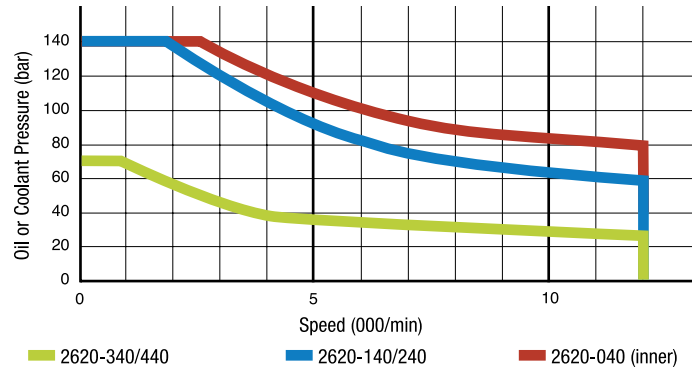

With Ø 108 mm flanged rotor		With Ø 88 mm flanged rotor		With Ø 81 mm flanged rotor		Inner Passage		Outer Passage		Notes	
Ordering Number	Supply Connections	Ordering Number	Supply Connections		Ordering Number	Supply Connections	Media	Max. Pressure {bar}	Media		Max. Pressure {bar}
	Inner and Outer Passage		Inner Passage	Outer Passage						Inner and Outer Passage	
2620-040-252	1/4 NPT	2620-042-940	G1/4"	G1/4"	2620-040-157	1/4 NPT	Hydraulic oil	140	Hydraulic oil	70	
2620-140-252	1/4 NPT	2620-142-940	G3/8"	G1/8"	2620-140-157	1/4 NPT	Hydraulic oil	140	Air	6	Air seals may be lubricated through oil cup or by using oiled air.
2620-160-252	1/4 NPT	2620-162-940	G3/8"	G1/8"	2620-160-157	1/4 NPT	Hydraulic oil	140	Air	10	
2620-240-252	1/4 NPT	2620-242-940	G3/8"	G1/8"	2620-240-157	1/4 NPT	Coolant	140	Air	6	
2620-260-252	1/4 NPT	2620-262-940	G3/8"	G1/8"	2620-260-157	1/4 NPT	Coolant	140	Air	10	
2620-340-252	1/4 NPT	2620-342-940	G1/4"	G1/4"	2620-340-157	1/4 NPT	Air	6	Hydraulic oil	70	Air seals require no external lubrication.
2620-360-252	1/4 NPT	2620-362-940	G1/4"	G1/4"	2620-360-157	1/4 NPT	Air	10	Hydraulic oil	70	
2620-440-252	1/4 NPT	2620-442-940	G1/4"	G1/4"	2620-440-157	1/4 NPT	Air	6	Coolant	70	
2620-460-252	1/4 NPT	2620-462-940	G1/4"	G1/4"	2620-460-157	1/4 NPT	Air	10	Coolant	70	

DEUBLIN

Deu-Plex Air and Hydraulic Unions



- Duoflow design
- Self-supported rotating union
- Flanged rotor
- Balanced mechanical seals
- Seal combination for 1590:
Carbon Graphite/Ceramic
- Seal combinations for 1579:
Carbon Graphite/Ceramic - standard
Tungsten Carbide/Ceramic - E.L.S.
- Full-media flow
- Aluminum housing
- Cast iron rotor
- Oil cup (3-5 drops/month for 1590)

Operating Data

Maximum Air Pressure (1590)*	150 PSI	10 bar
Maximum Hydraulic Pressure (1579)**	1,000 PSI	70 bar
Maximum Vacuum (1590)	28" Hg	6.7 kPa
Maximum Speed	1,500 RPM	1,500/min
Maximum Temperature	250°F	120°C

* Only one passage should be pressurized at a time.

** Operation at maximum pressure combined with maximum speed should be avoided. Pressure rating is for inner passage only. Contact **DEUBLIN** if outer passage or both passages are pressurized.

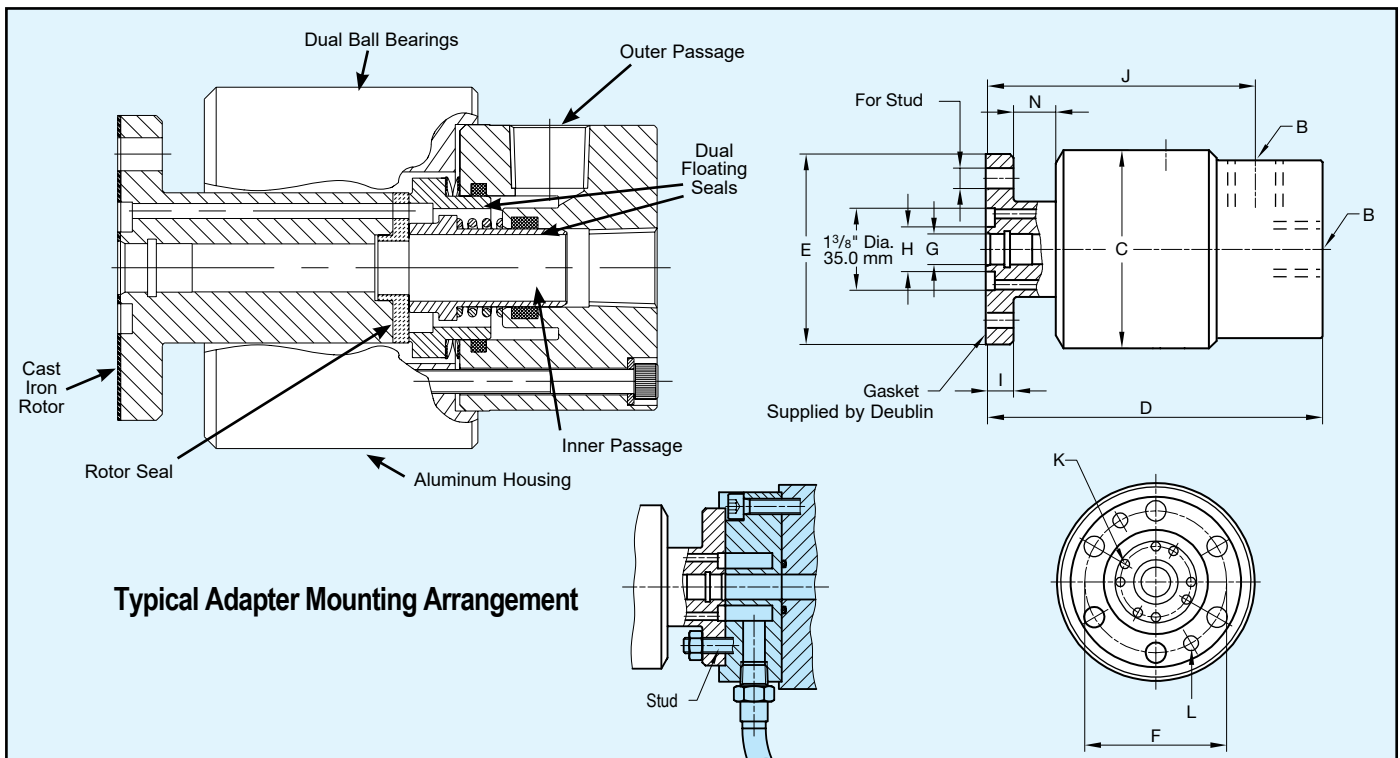

Typical Adapter Mounting Arrangement

B Port NPT	Ordering No.	Media	C	D	E Pilot	F Bolt Circle	G Area	H	I	J	K Area	L Dowel	N	Stud	Shpg. Wt.
(2)x½"	1590-000	Air	3 ⁵ / ₁₆ "	5 ¹⁹ / ₃₂ "	3.189"	2 ³ / ₁₆ "	.1964in ²	3/4"	7/16"	4 ⁷ / ₁₆ "	.1536in ²	1/4"	5/8"	5/16"	7#
			84	142	81.00 80.95	60.3	126mm ²	19	11	113	100mm ²	6.3	15.8	M8	3.2 Kg
	1579-000 STD	Hydraulic Oil	3 ⁵ / ₁₆ "	5 ¹⁹ / ₃₂ "	3.189"	2 ³ / ₁₆ "	.1964in ²	3/4"	7/16"	4 ⁷ / ₁₆ "	.1536in ²	1/4"	5/8"	5/16"	7#
			84	142	81.00 80.95	60.3	126mm ²	19	11	113	100mm ²	6.3	15.8	M8	3.2 Kg
	1579-041 ELS	Hydraulic Oil	3 ⁵ / ₁₆ "	5 ¹⁹ / ₃₂ "	3.189"	2 ³ / ₁₆ "	.1964in ²	3/4"	7/16"	4 ⁷ / ₁₆ "	.1536in ²	1/4"	5/8"	5/16"	7#
			84	142	81.00 80.95	60.3	126mm ²	19	11	113	100mm ²	6.3	15.8	M8	3.2 Kg

DEUBLIN

4-Passage Multi-Purpose, Multi-Media Unions



- 4-passage design
- Self-supported rotating union
- Flanged rotor
- Drain passage prevents interpassage leakage
- Special seals
- Hardened sealing surface
- Brass housing
- Stainless steel rotor
- Widely spaced ball bearings to withstand side load
- 5-passage available

Operating Data

Maximum Air Pressure*	150 PSI	10 bar
Maximum Hydraulic Pressure*	850 PSI	60 bar
Maximum Vacuum	28" Hg	6.7 kPa
Maximum Speed	250 RPM	250/min

Maximum Temperature 175°F >175°F consult DEUBLIN

Slow speed or turnable applications not exceeding 10 RPM
 Maximum Hydraulic Pressure 3,600 PSI 250 bar

* Operating conditions vary depending on the application and must be adjusted so as not to exceed the maximum union housing temperature rating of 195°F.

A drain port is provided to collect leakage under normal operation. A vent is provided between ports 2 and 3 to allow use with two medias eliminating cross contamination.

Example: Air in 1 & 2 and hydraulic oil in 3 & 4.

Customer's Shaft End

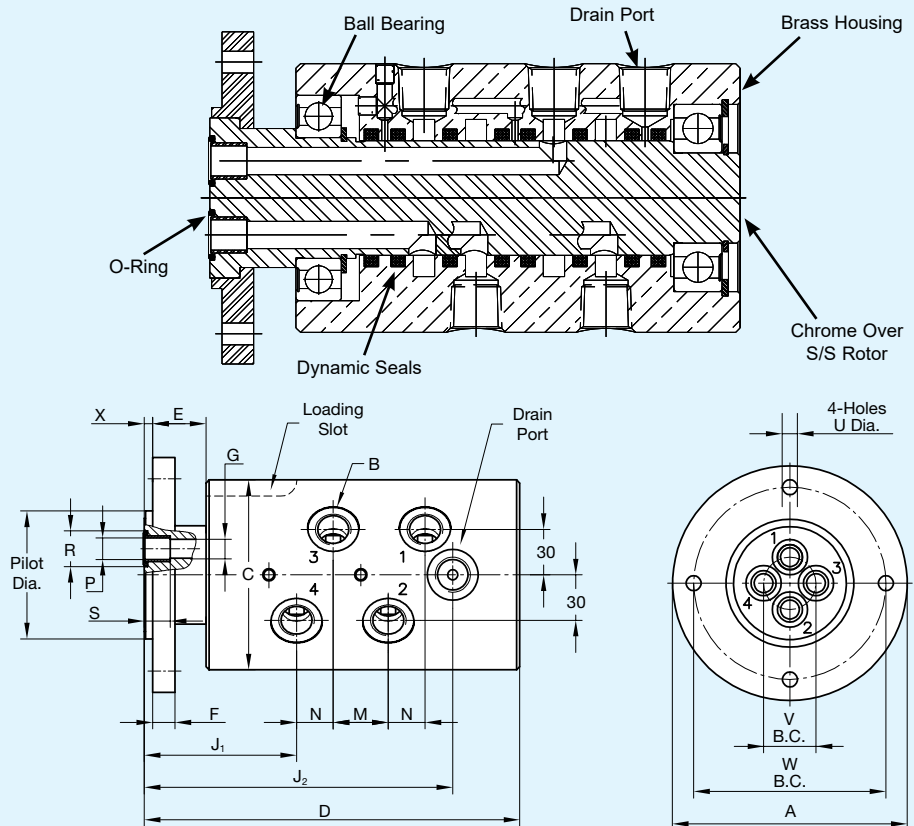
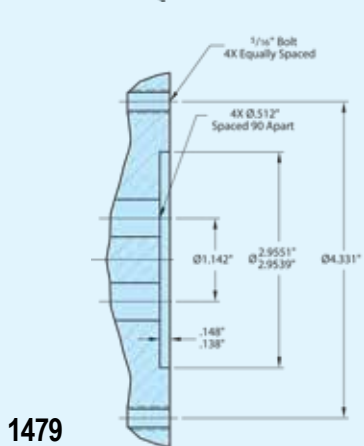
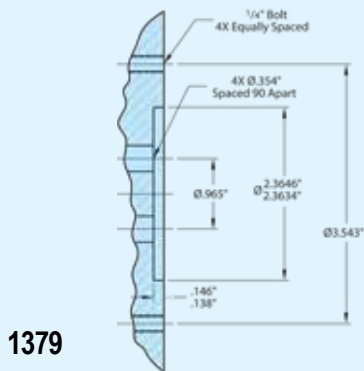

B Port	Order No. Model	A Dia.	C Dia.	D	E	F	G Dia.	J ₁ Lock-up	J ₂	M	N	P Dia.	R Dia.	S	U Dia.	V B.C. Dia.	W B.C. Dia.	Pilot Dia.	X	Shpg. Wt.
(4) x 3/8" NPT	1379-460	4 ²¹ / ₆₄ "	3 ¹ / ₂ "	6 ¹⁵ / ₁₆ "	1"	1 ³ / ₃₂ "	2 ³ / ₆₄ "	2 ²⁷ / ₃₂ "	5 ¹⁹ / ₃₂ "	1 ¹ / ₃₂ "	2 ³ / ₃₂ "	4.744" 4.724"	.660" .655"	1/2"	9/32"	3 ¹ / ₃₂ "	3.543	2.3622" 2.3614"	5/32"	16.7#
(4) x G ³ / ₈ " (BSP)	1379-160	110	89	176	25	10.5	9	72	142	26	18	12.05 12.00	16.75 16.65	12	7.2	24.5	90	60.000 59.981	4	7.6 Kg
(4) x 1/2" NPT	1479-400	5 ⁷ / ₈ "	4 ¹ / ₄ "	7 ³¹ / ₃₂ "	1"	1 ⁷ / ₃₂ "	1/2"	3 ³ / ₁₆ "	6 ²¹ / ₃₂ "	1 ¹ / ₃₂ "	2 ⁹ / ₃₂ "	5.910" 5.905"	.778" .773"	1 ⁹ / ₃₂ "	1 ¹ / ₃₂ "	1 ¹ / ₆₄ "	4.331	2.953" 2.952"	5/32"	28#
(4) x G ¹ / ₂ " (BSP)	1479-100	130	108	202	25	13.5	13	81	169	32	23	15.05 15.00	19.75 19.65	15	9	29	110	75.000 74.981	4	12.7 Kg

DEUBLIN

Low Speed Air, Hydraulic, Brake Fluid Unions

- Monoflow design
- Self-supported rotating union
- Steel rotor nickel-plated
- Special bearing
- Aluminum housing



Operating Data

Maximum Air Pressure	150 PSI	10 bar
Maximum Vacuum	28" Hg	6.7 kPa
Maximum Hydraulic Pressure*	3,000 PSI	207 bar
Maximum Speed*	250 RPM	250/min
Maximum Temperature	250°F	120°C

* Union is designed for continuous operation at either maximum speed or maximum pressure. If operating conditions are close to maximum pressure and speed simultaneously, consult **DEUBLIN**.

-045 Rotor

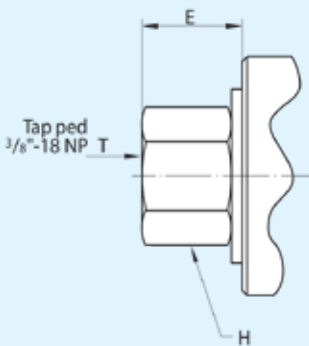

-023 & -048 Rotors

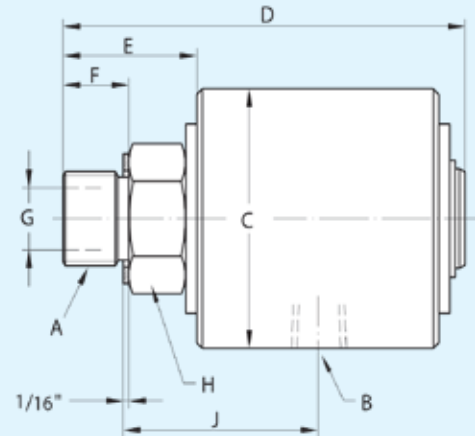
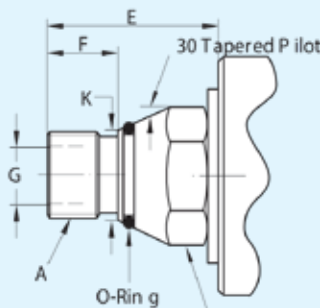

B Port NPT	Ordering Number		A Rotor Thread	C	D	E	F	G Rotor Hole	H* Across Flats	J Lock-up	K	Shpg. Wt.
	Air-Hydraulic-Vacuum	Brake Fluid										
1/4"	17-025-012	17-086-012	5/8"-18 UNF RH	1 1/2"	3 1/4"	1 1/8"	5/8"	5/16"	22	1 17/32"	-	1/2#
	17-025-041	17-086-041	3/8" NPT RH	1 1/2"	3 1/4"	1 1/8"	5/8"	5/16"	22	1 25/32"	-	1/2#
	17-025-045	17-086-045	3/8" NPT (FEM) RH	1 1/2"	2 5/16"	1 3/16"	-	5/16"	22	1 13/32"	-	1/2#
	17-025-023	17-086-023	5/8"-18 UNF T.PLT. RH	1 1/2"	3 1/2"	1 11/32"	5/8"	5/16"	22	-	5/8"	1/2#
	17-025-039	17-086-039	G 3/8" (BSP) RH	38	83.3	28.5	16.6	8	22	39	-	.3 Kg
	17-025-046	17-086-046	M16 x 2 RH	38	83.3	28.5	15.8	8	22	39	-	.3 Kg
	17-025-048	17-086-048	M16x2 T.PLT. RH	38	89	35	15.8	8	22	-	15.8	.3 Kg
1/2"	21-001-109	21-063-109	1"-14 UNS RH	2 3/4"	4 3/8"	1 1/2"	3/4"	5/8"	36	2 1/4"	-	2 1/2#
	21-001-101	21-063-101	3/4" NPT RH	2 3/4"	4 1/16"	1 5/8"	7/8"	5/8"	36	2 1/2"	-	2 1/2#
	21-001-122	21-063-122	G 3/4" (BSP) RH	70	116	38	19	15.8	36	57	-	1.2 Kg
	21-001-121	21-063-121	M22 x 1.5 RH	70	111	33	14.2	12.7	36	57	-	1.2 Kg

*Metric

DEUBLIN

Tandem Air, Hydraulic, Brake Fluid Dual Passage Unions

- Duoflow (Tandem) design
- Self-supported rotating union
- No interpassage leakage on the duoflow design
- Steel rotor nickel-plated
- Special bearing
- Aluminum housing



Operating Data

Maximum Air Pressure	150 PSI	10 bar
Maximum Vacuum	28" Hg	6.7 kPa
Maximum Hydraulic Pressure*	3,000 PSI	207 bar
Maximum Speed*	250 RPM	250/min
Maximum Temperature	250°F	120°C

* Union is designed for continuous operation at either maximum speed or maximum pressure. If operating conditions are close to maximum pressure and speed simultaneously, consult **DEUBLIN**.

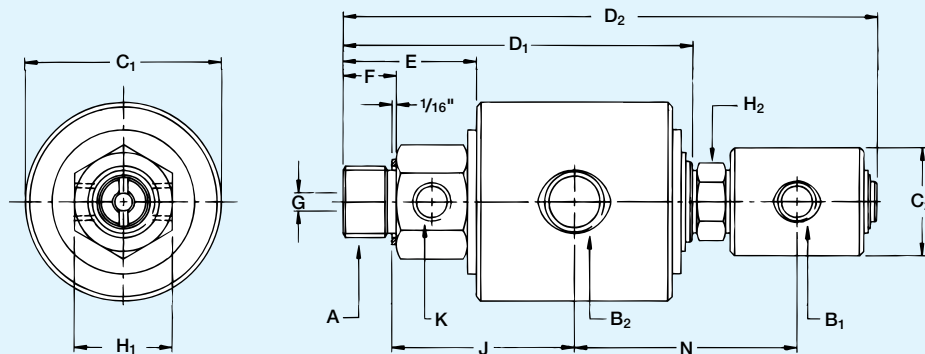
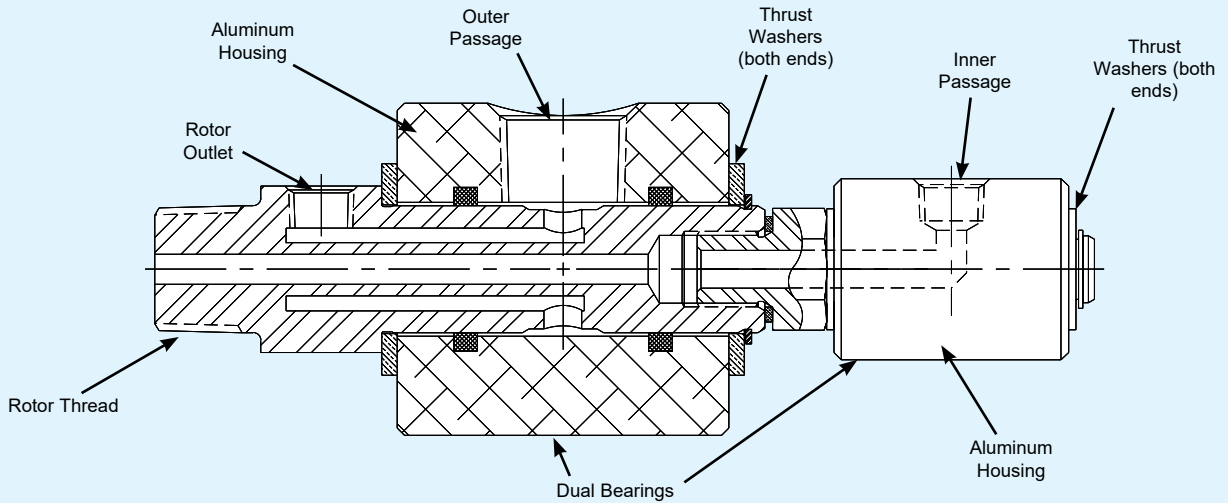

Inlet Ports NPT	Ordering Number		A Rotor Thread	C ₁	C ₂	D ₁	D ₂	E	F	G	H ₁ * Across Flats	H ₂ * Across Flats	J Lock- Up	K Tap NPT	N Lock- up	Shpg. Wt.
	Air-Hydraulic-Vacuum	Brake Fluid														
B ₁ B ₂ 1/4" 1/2"	2117-001-109	2117-018-136	3/4" NPT RH	2 3/4"	1 1/2"	4 53/64"	7 11/16"	1 15/16"	7/8"	1/4"	36	22	2 7/8"	1/4"	3 3/16"	3#
	2117-001-103	2117-018-113	1"-14 UNS RH	2 3/4"	1 1/2"	4 53/64"	7 11/16"	1 7/8"	1 1/16"	1/4"	36	22	2 9/16"	1/4"	3 3/16"	3#
	2117-001-105	2117-018-137	G 3/4" (BSP) RH	70	38	124	195	47	17	6	36	22	65	1/4"	81	1.4 Kg

*Metric

DEUBLIN

Deu-Plex Low Speed Air-Hydraulic Unions



- Duoflow design
- Self-supported rotating union
- Composite bearing
- Vent holes between passages
- Special seals
- Hardened sealing surface
- Aluminum housing
- Steel rotor

- Optional:
- Tandem model as triple-passage design

Operating Data

Maximum Air Pressure	150 PSI	10 bar
Maximum Vacuum Pressure	28" Hg	6.7 kPa
Maximum Hydraulic Pressure*	3,000 PSI	207 bar
Maximum Speed*	250 RPM	250/min
Torque for Model 1690	7 ft.lbs	9.5 Nm
Model 1790	18 ft.lbs	24 Nm
Model 1890	22 ft.lbs	29.8 Nm
Maximum Temperature	250°F	120°C

* Union is designed for continuous operation at either maximum speed or maximum pressure. If operating conditions are close to maximum pressure and speed simultaneously, consult **DEUBLIN**.

Models with inner rotors

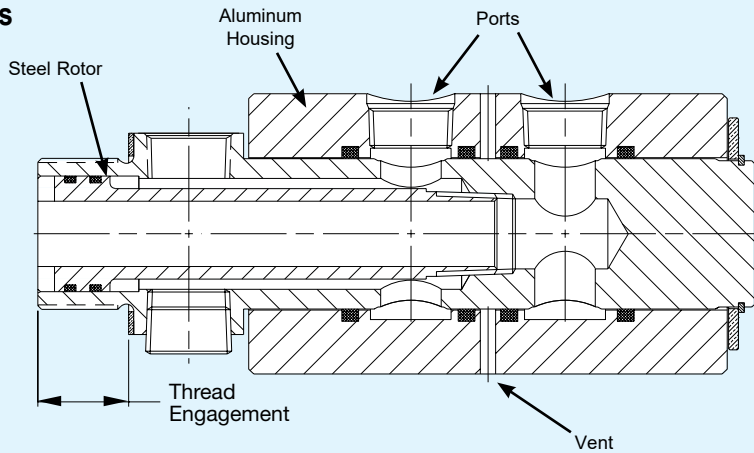

Models without inner rotors can be used for coaxial feed applications as shown below.

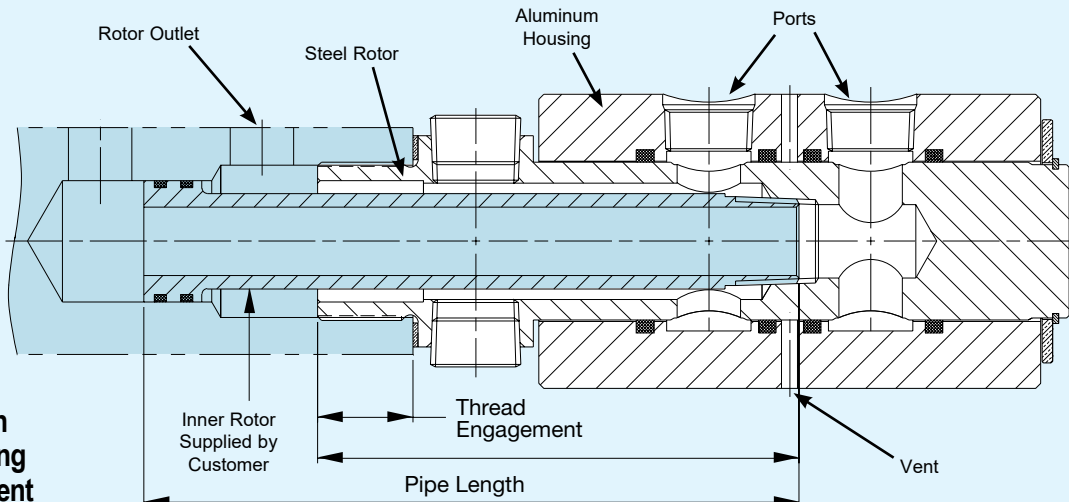
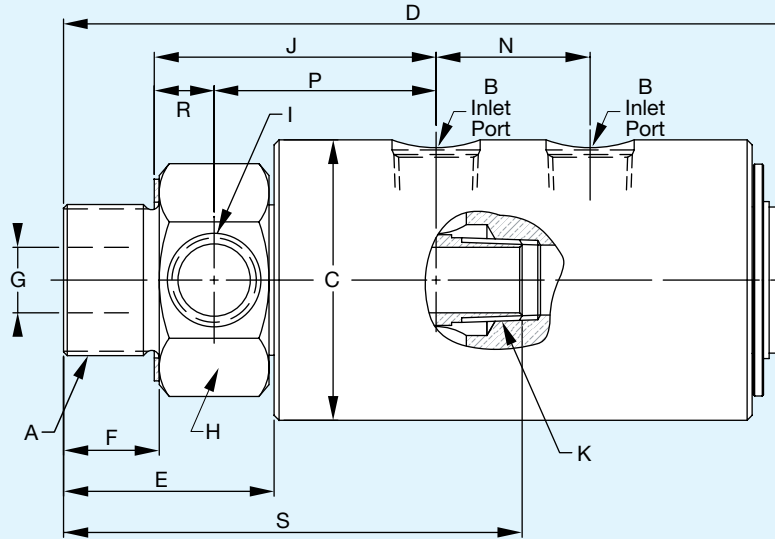

Illustration of mounting arrangement

Double Passage Models



*These models are supplied without inner rotors.

B Port NPT	Ordering No.	A Rotor Thread	C Dia.	D	E	F	G Rotor ID	H** Across Flats	I Tap NPT	J Lock-up	K Tap NPT	N	P	R	S	Shpg Wt.
	Model															
(2) x 1/4"	1690-000-115	1" NPT RH	2 5/8"	5 7/8"	2 3/16"	1 1/8"	5/16"	46	1/4"	2 5/8"	1/4"	1 5/32"	1 11/16"	1/2"	-	3 1/2#
	1690-000-102*	1" NPT RH	2 5/8"	5 7/8"	2 3/16"	1 1/8"	1 1/16"	46	1/4"	2 5/8"	1/4"	1 5/32"	1 11/16"	1/2"	3 25/32"	3 1/2#
	1690-000-168	G1" (BSP) RH	66.6	150	55.5	18	7.9	46	1/4"	67.8	1/4"	29.4	42.9	17	-	1.6 Kg
	1690-000-105*	G1" (BSP) RH	66.6	150	55.5	18	17.4	46	1/4"	67.8	1/4"	29.4	42.9	17	96	1.6 Kg
(2) x 1/2"	1790-001-113	1 1/2" NPT RH	3"	8 3/16"	2 15/32"	1 1/8"	3/8"	50.8	1/2"	3 3/4"	1/2"	1 29/32"	2 5/8"	5/8"	-	6 1/2#
	1790-001-101*	1 1/2" NPT RH	3"	8 3/16"	2 15/32"	1 1/8"	1 1/16"	50.8	1/2"	3 3/4"	1/2"	1 29/32"	2 5/8"	5/8"	5 1/16"	6 1/2#
	1790-001-114	G1 1/2" (BSP) RH	76	208	63	28	16	50.8	1/2"	84.2	1/2"	42	67	15.5	-	3 Kg
	1790-001-112*	G1 1/2" (BSP) RH	76	208	63	28	27	50.8	1/2"	84.2	1/2"	42	67	15.5	129	3 Kg
(2) x 3/4"	1890-100	1 1/2" NPT RH	3 1/2"	8 7/8"	2 5/8"	1 3/16"	1 3/16"	63.5	3/4"	4 3/32"	3/4"	1 29/32"	2 3/4"	1 1/16"	-	9 1/2#
	1890-110*	1 1/2" NPT RH	3 1/2"	8 7/8"	2 5/8"	1 3/16"	1 3/16"	63.5	3/4"	4 3/32"	3/4"	1 29/32"	2 3/4"	1 1/16"	5 13/16"	9 1/2#
	1890-060	G1 1/2" (BSP) RH	88.9	225.4	66.6	30.2	20.6	63.5	3/4"	91.3	3/4"	48.4	69.8	17.5	-	4.4 Kg
	1890-063*	G1 1/2" (BSP) RH	88.9	225.4	66.6	30.2	34.9	63.5	3/4"	91.3	3/4"	48.4	69.8	17.5	147.6	4.2 Kg

Triple Passage Models

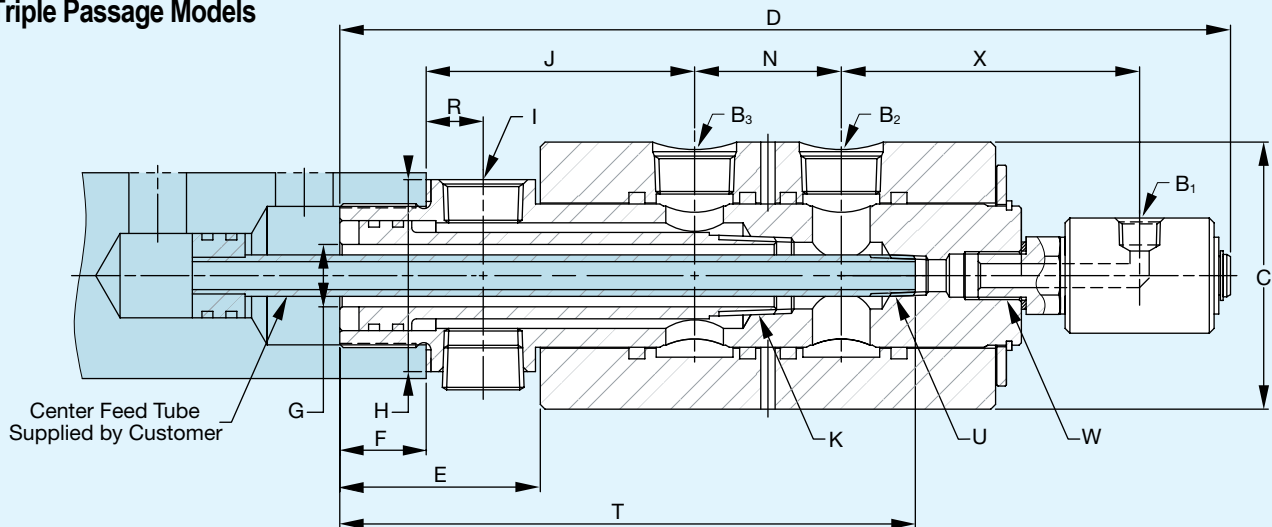

Center Feed Tube Supplied by Customer

Inlet Ports NPT	Ordering No.	A Rotor Thread	C	D	E	F	G Rotor Hole	H** Across Flats	I Tap NPT	J Lock-up	K Tap NPT	N	P	R	T	U Tap NPT	W Tap	X	Shpg. Wt.
	Model																		
B ₁ B ₂ B ₃ 1/4" 3/4" 3/4"	1890-116	1 1/2" NPT RH	3 1/2"	11 13/32"	2 5/8"	1 3/16"	1 3/16"	63.5	3/4"	4 3/32"	3/4"	1 29/32"	2 13/16"	1 1/16"	7 1/2"	1/4"	5/8"-18 UNF, RH	3 3/8"	10 3/4#
	1890-064	G1 1/2" (BSP) RH	88.9	293	66.6	30.2	20.6	63.5	3/4"	89	3/4"	48.4	69.8	17.5	190	1/4"	5/8"-18 UNF, RH	97.6	4.9 Kg

**Metric

DEUBLIN

1117 Series Bearingless "Closed Seal" Rotating Unions for Continuous Coolant Service

- Single passage for coolant or MQL
- Closed seals for transfer line and similar applications
- Full-flow design has no obstructions to trap chips or debris
- Balanced mechanical seals made from silicon carbide for long life even under difficult operating conditions
- Compact size can be adapted for custom installations
- Anodized aluminum housing resists corrosion



Operating Data

Media	Water-based Coolant		
Filtration	ISO 4406 Class 17/15/12, max. 60 micron		
Maximum Speed	See chart		
Maximum Pressure	See chart		
Maximum Flow	82 l/min	21.6 gpm	Standard
	24.3 l/min	6.4 gpm	High Pressure (HP)
Maximum Temperature	2.7 l/min	0.7 gpm	Very High Pressure (VHP)
	160°F	71°C	



DO NOT RUN DRY

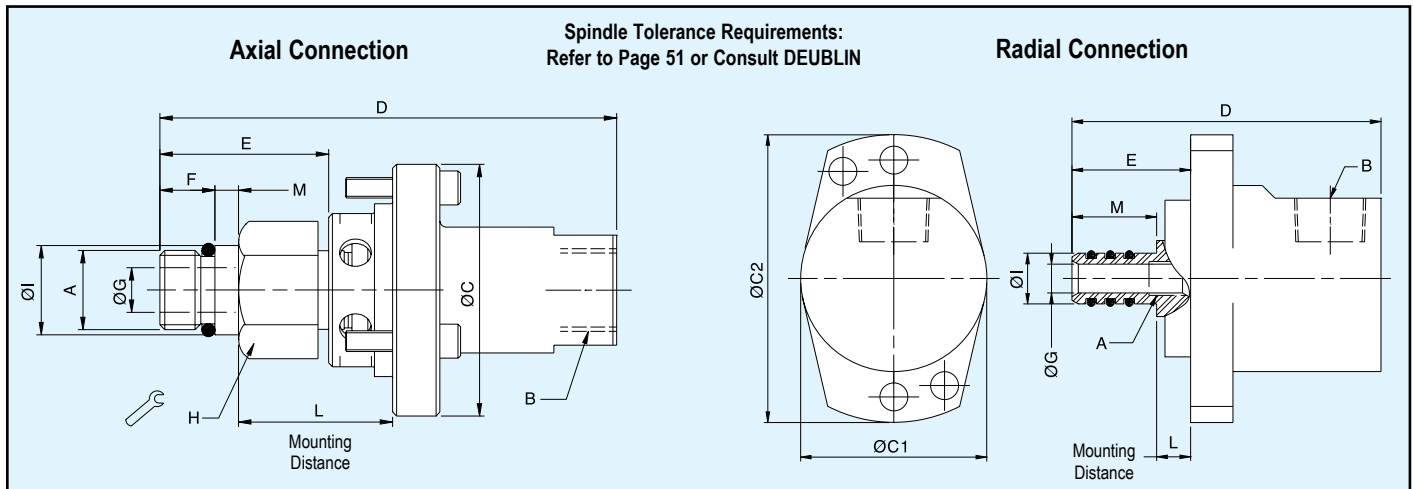
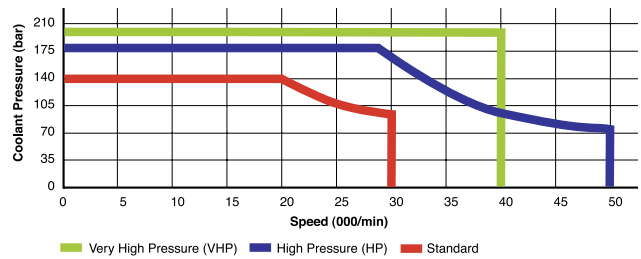

Spindle Tolerance Requirements:
Refer to Page 51 or Consult DEUBLIN

	Ordering Number	B Supply Connection	C Overall Diameter	D Overall Length	L Mounting Distance	A Rotor Connection	E Rotor Length	G Bore Diameter	H* Across Flats	I Pilot Diameter	M Pilot Length	Max Speed (rpm)
Radial	1117-706	G 3/8"	44	72	7.5 / 7.0	12f7	21	7	NA	11.984 / 11.966	20	10,000 ^A
	1117-711	3/8" NPT	44 x 68	73	8.0 / 7.5	12f7	28	7	NA	11.984 / 11.966	20	10,000 ^A
	1117-792	G 3/8"	44	72	7.5 / 7.0	12f7	21	7	NA	11.984 / 11.966	20	30,000
Standard	1117-002-110	3/8" NPT	51	95	31.7/30.5	5/8"-18 UNF RH	37	9	24	0.6555" / 0.6553"	5	30,000
	1117-002-111	3/8" NPT	51	95	31.7/30.5	5/8"-18 UNF LH	37	9	24	0.6555" / 0.6553"	5	30,000
	1117-002-116	3/8" NPT	51	92	31.7/30.5	M16 x 1.5 LH	34	9	24	17.993 / 17.988	5	30,000
	1117-058-116	G 3/8"	51	92	31.7/30.5	M16 x 1.5 LH	34	9	24	17.993 / 17.988	5	30,000
	1117-028-374	20 h5	40	63	25	M12 x 1.25 LH	28	6	17	12.994 / 12.989	6	46,000
	1117-789	25f7	36 x 52	56	23.7/23.3	12f7	28	7	NA	11.984 / 11.996	20	30,000
	1117-490-493	3/8" PT	54	105	39.6/38.6	M12 x 1.25 LH	40	5	18	14.000 / 13.995	5	50,000
VHP	1117-063-294	G 1/4"	51	92	31.7/30.5	M16 x 1.5 LH	34	5	24	17.993 / 17.988	5	40,000

Note A: Union includes integral lip seal for added spindle protection. *Metric

DEUBLIN

1129 Series Bearingless Pop-Off™ Rotating Unions for Coolant Service

- Single passage for coolant or MQL
- Patented Pop-Off™ technology allows unlimited dry running without media pressure
- Pop-Off stroke of 0.7-3.0 mm compensates for thermal expansion of spindle during extended operation as well as variations in drawbar position
- Full-flow design has no obstructions to trap chips or debris
- Balanced mechanical seals made from silicon carbide for long life even under difficult operating conditions
- Anodized aluminum housing resists corrosion



Operating Data

Media	Water-based Coolant	
Filtration	MQL (oil mist) up to 10 bar (145 psi)	
Maximum Speed	ISO 4406 Class 17/15/12, max. 60 micron	Standard
	30,000 min ⁻¹ 30,000 rpm	High Pressure (HP)
Maximum Pressure	40,000 min ⁻¹ 46,000 rpm	
	140 bar 2,030 psi	
Maximum Flow	24.3 l/min 6.4 gpm	
Maximum Temperature	53.0 l/min 14.0 gpm	
	160°F 71°C	



NO AIR PRESSURE WITH ROTATION

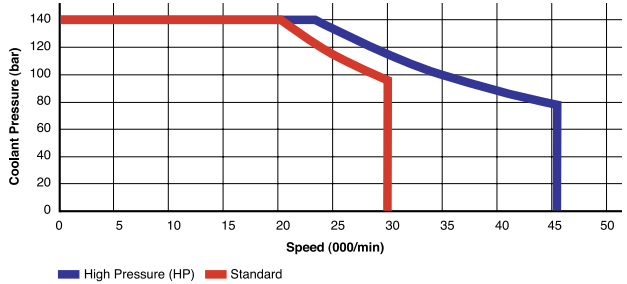

Dual Connection

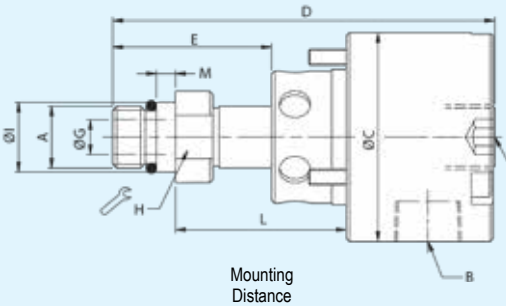

Spindle Tolerance Requirements:
Refer to Page 51 or Consult DEUBLIN

Axial Connection

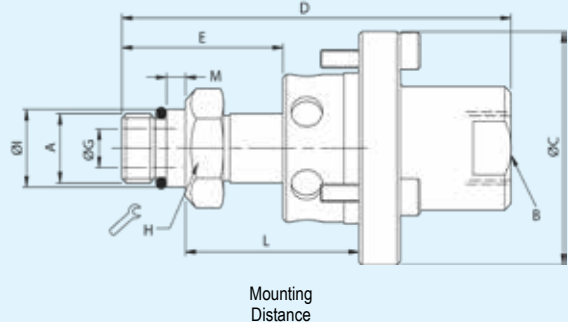

	Ordering Number	B Supply Connection	C Overall Diameter	D Overall Length	L Mounting Distance	A Rotor Connection	E Rotor Length	G Bore Diameter	H Across Flats	I Pilot Diameter	M Pilot Length	Max Speed (rpm)
Dual Connection	1129-033-301	G 3/8"	54	97	44.0 / 43.0	M16 x 1.5 LH	40	9	24	17.993 / 17.988	5	30,000
	1129-033-327	G 3/8"	54	94	39.6 / 38.6	M12 x 1.25 LH	37	6	18	14.000 / 13.995	5	30,000
	1129-050-301	G 3/8"	54	101	44.0 / 43.0	M16 x 1.5 LH	40	9	24	17.993 / 17.988	5	30,000
	1129-859-731	G 3/8"	54	106	39.2 / 38.8	M12 x 1.25 LH	37	5	18	14.000 / 13.995	5	30,000
Standard	1129-016-301	3/8" PT	54	97	44.0 / 43.0	M16 x 1.5 LH	40	9	24	17.993 / 17.988	5	30,000
	1129-036-301	3/8" PT	54	98	44.0 / 43.0	M16 x 1.5 LH	40	9	24	17.993 / 17.988	5	30,000
	1129-036-327	3/8" PT	54	94	39.6 / 38.6	M12 x 1.25 LH	37	6	18	14.000 / 13.995	5	30,000
	1129-039-301	3/8" PT	54	97	44.0 / 43.0	M16 x 1.5 LH	40	9	24	17.993 / 17.988	5	30,000
	1129-730-731	G 3/8"	54	94	39.2 / 38.8	M12 x 1.25 LH	37	5	18	14.000 / 13.995	5	30,000
	1129-927-929	G 3/8"	54	101	39.2 / 38.8	M14 x 1.5 LH	37	7	24	14.494 / 14.489	5	30,000
	1129-330-331	30 mm Counterbore	48	72	37.5	M12 x 1 LH	28	6	22.2	13.000 / 12.992	7	20,000
Axial Connection	1129-330-342	30 mm Counterbore	48	72	37.5	M12 x 1 RH	28	6	22.2	13.000 / 12.992	7	20,000
	HP	1129-052-137	20 mm Counterbore	40	68	25	M12 x 1.25 LH	28	6	17	13.000 / 12.995	6

DEUBLIN

1101 Series "Closed Seal"

Rotating Unions for Continuous Coolant Service



- Single passage for coolant or MQL
- Closed seals for transfer line and similar applications
- Full-flow design has no obstructions to trap chips or debris
- Bearing-supported with threaded rotor for easy installation
- Deep groove radial ball bearings for smooth operation
- Labyrinth system and large vents to protect ball bearings
- Balanced mechanical seals made from silicon carbide for long life even under difficult operating conditions
- Anodized aluminum housing resists corrosion

Operating Data

Media	Water-based Coolant	
	MQL (oil mist) up to 10 bar (145 psi)	
Filtration	ISO 4406 Class 17/15/12, max. 60 micron	
Maximum Speed	15,000 min ⁻¹	15,000 rpm
Maximum Pressure	105 bar	1,520 psi
Maximum Flow	20 l/min	5.3 gpm
Maximum Temperature	160°F	71°C



DO NOT RUN DRY

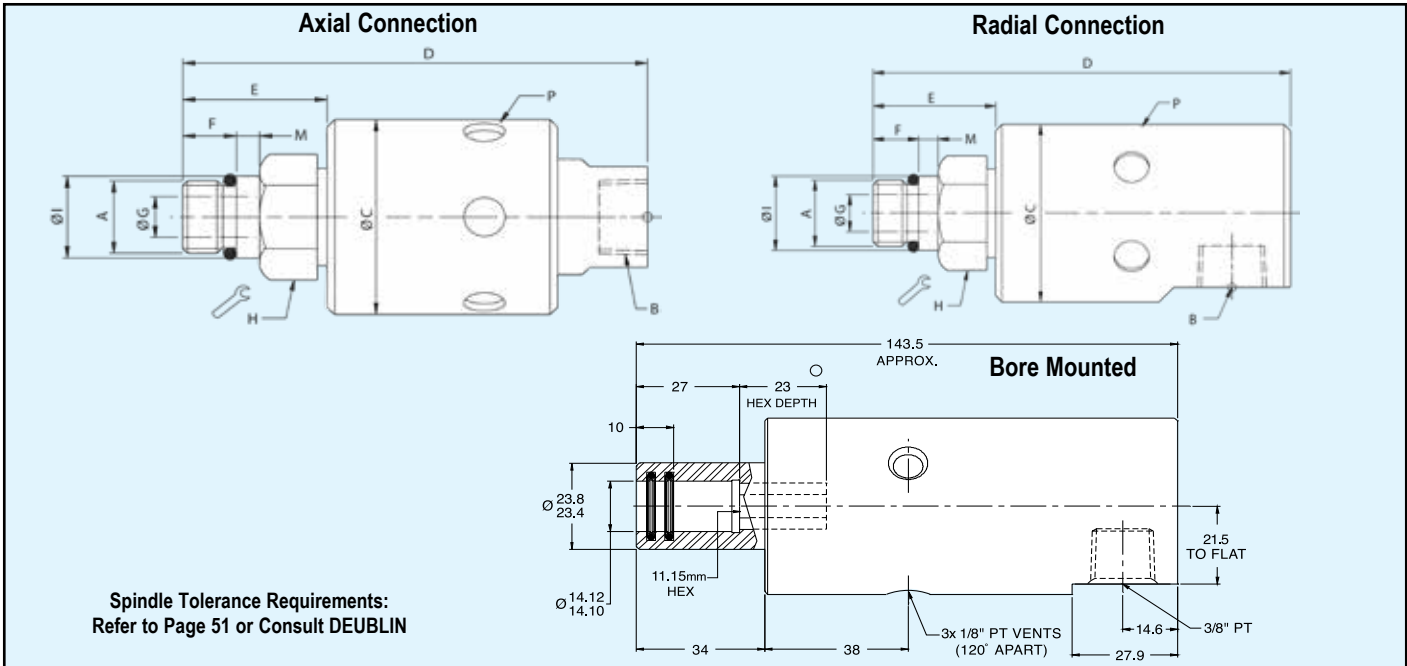
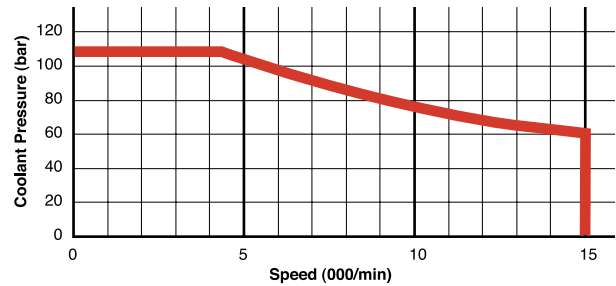

	Ordering Number	B Supply Connection	C Overall Diameter	D Overall Length	P Vent Size (6 X 60°)	A Rotor Connection	E Rotor Length	F Thread Length	G Bore Diameter	H* Across Flats	I Pilot Diameter	M Pilot Length
Axial Connection	1101-235-238	3/8" NPT	43	100	9	5/8"-18 UNF LH	33	14	6	24	0.6555" / 0.6553"	5
	1101-235-239	3/8" NPT	43	100	9	5/8"-18 UNF RH	33	14	6	24	0.6555" / 0.6553"	5
	1101-235-343	3/8" NPT	43	97	9	M16 x 1.5 LH	30	11	6	24	17.993 / 17.988	5
	1101-235-424	3/8" NPT	43	93	9	M10 x 1 LH	27	11	3.2	24	10.994 / 10.989	3
	1101-359-343	G 3/8"	43	102	9	M16 x 1.5 LH	30	11	6	24	17.993 / 17.988	5
	1101-620-343	3/8" NPT	43	96	9	M16 x 1.5 LH	30	11	6	24	17.993 / 17.988	5
Radial	1101-195-343	G 3/8"	43	97	9	M16 x 1.5 LH	30	11	6	24	17.993 / 17.988	5
	1101-615-598 ^A	3/8" PT	49	144	3 x 1/8" PT	14 mm female hex	34	NA	6	NA	14.122 / 14.097	27

Note A: This union is a bore-mounted design. *Metric

DEUBLIN

1116 Series "Closed Seal"

Rotating Unions for Continuous Coolant Service



- Single passage for coolant or MQL
- Closed seals for transfer line and similar applications
- Full-flow design has no obstructions to trap chips or debris
- Bearing-supported with threaded rotor for easy installation
- Deep groove radial ball bearings for smooth operation
- Labyrinth system and large vents to protect ball bearings
- Balanced mechanical seals made from silicon carbide for long life even under difficult operating conditions
- Anodized aluminum housing resists corrosion

Operating Data

Media	Water-based Coolant	
	MQL (oil mist) up to 10 bar (145 psi)	
Filtration	ISO 4406 Class 17/15/12, max. 60 micron	
Maximum Speed	12,000 min ⁻¹	12,000 rpm
Maximum Pressure	70 bar	1,015 psi
Maximum Flow	82 l/min	21.6 gpm
Maximum Temperature	160°F	71°C



DO NOT RUN DRY

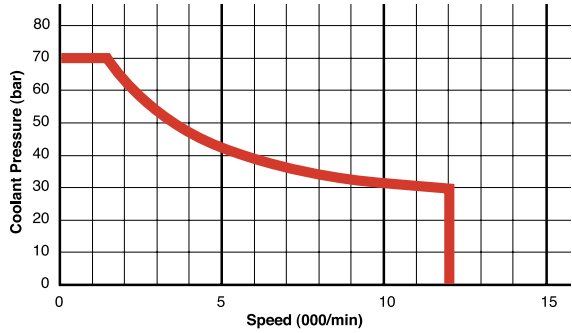

Axial Connection

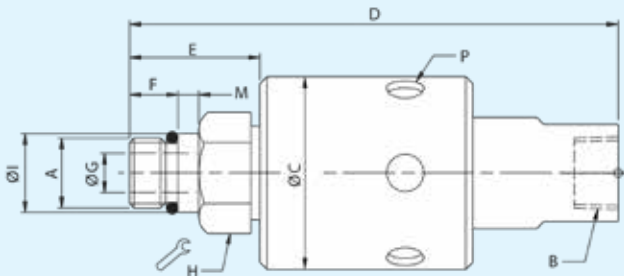

Radial Connection

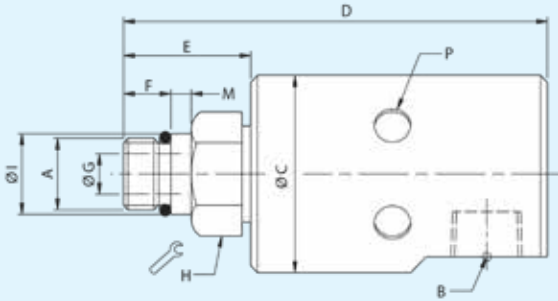

Spindle Tolerance Requirements:
Refer to Page 51 or Consult DEUBLIN

	Ordering Number	B Supply Connection	C Overall Diameter	D Overall Length	P Vent Size (6 X 60°)	A Rotor Connection	E Rotor Length	F Thread Length	G Bore Diameter	H* Across Flats	I Pilot Diameter	M Pilot Length
Axial Connection	1116-048-064	1/4" NPT	44	115	9	5/8"-18 UNF RH	33	14	9	24	0.6555" / 0.6553"	5
	1116-048-463	1/4" NPT	44	112	9	M16 x 1.5 LH	30	11	9	24	17.993 / 17.988	5
	1116-485-463	G 1/4"	44	112	9	M16 x 1.5 LH	30	11	9	24	17.993 / 17.988	5
	1116-580-343	3/8" PT	44	112	9	M12 x 1.25 LH	30	11	6	24	13.994 / 13.989	5
	1116-600-059	3/8" NPT	44	115	9	5/8"-18 UNF LH	33	14	9	24	0.6555" / 0.6550"	5
	1116-600-463	3/8" NPT	44	112	9	M16 x 1.5 LH	30	11	9	24	17.993 / 17.988	5
	1116-610-463	G 3/8"	44	112	9	M16 x 1.5 LH	30	11	9	24	17.993 / 17.988	5
Radial Connection	1116-090-059	3/8" NPT	44	106	9	5/8"-18 UNF LH	33	14	9	24	0.6555" / 0.6553"	5
	1116-090-064	3/8" NPT	44	106	9	5/8"-18 UNF RH	33	14	9	24	0.6555" / 0.6553"	5
	1116-090-463	3/8" NPT	44	103	9	M16 x 1.5 LH	30	11	9	24	17.993 / 17.988	5
	1116-516-463 ^A	G 3/8"	44	102	9	M16 x 1.5 LH	30	11	9	24	17.993 / 17.988	5
	1116-555-463	G 3/8"	44	103	9	M16 x 1.5 LH	30	11	9	24	17.993 / 17.988	5

Note A: Also suitable for Cutting Oil and Air. *Metric

DEUBLIN

1109 Series Pop-Off™

Rotor-Mounted Rotating Unions for Coolant Service with Dry Running

- Single passage for coolant or MQL
- Patented Pop-Off™ technology allows unlimited dry running without media pressure
- Full-flow design has no obstructions to trap chips or debris
- Bearing-supported with threaded rotor for easy installation
- Dual ABEC 7 (ISO class P4) angular contact ball bearings
- Labyrinth system and large vents to protect ball bearings
- Balanced mechanical seals made from silicon carbide for long life even under difficult operating conditions
- Anodized aluminum housing resists corrosion



Operating Data

Media	Water-based Coolant	
Filtration	MQL (oil mist) up to 10 bar (145 psi) ISO 4406 Class 17/15/12, max. 60 micron	
Maximum Speed	20,000 min ⁻¹	20,000 rpm
Maximum Pressure	See chart	
Maximum Flow	82 l/min	21.6 gpm Standard
	24.3 l/min	6.4 gpm High Pressure (HP)
Maximum Temperature	160°F	71°C

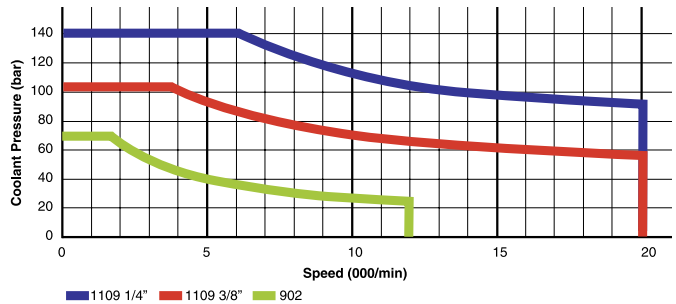

Axial Connection

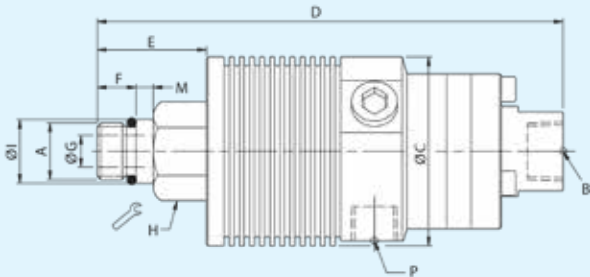

Radial Connection

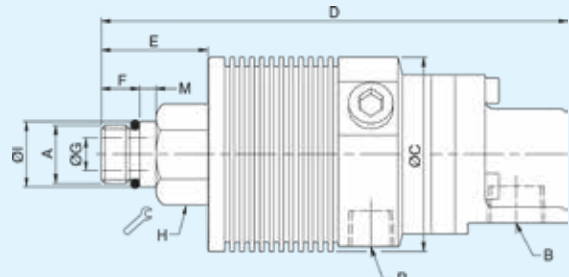

	Ordering Number	B Supply Connection	C Overall Diameter	D Overall Length	P Vent Size (3 X 120°)	A Rotor Connection	E Rotor Length	F Thread Length	G Bore Diameter	H* Across Flats	I Pilot Diameter	M Pilot Diameter
Standard	1109-011-165	3/8" NPT Axial	53	132	1/4" NPT	5/8"-18 UNF LH	34	11	9	24	0.6555" / 0.6553"	5
	1109-021-188	G 3/8" Axial	53	129	G 1/4"	M16 x 1.5 LH	31	11	9	24	17.993 / 17.988	5
	1109-041-188	3/8" PT Axial	53	129	1/4" PT	M16 x 1.5 LH	31	11	9	24	17.993 / 17.988	5
	1109-010-165	3/8" NPT Radial	53	138	1/4" NPT	5/8"-18 UNF LH	34	11	9	24	0.6555" / 0.6553"	5
	1109-020-188	G 3/8" Radial	53	135	G 1/4"	M16 x 1.5 LH	31	11	9	24	17.993 / 17.988	5
	1109-040-188	3/8" PT Radial	53	135	1/4" PT	M16 x 1.5 LH	31	11	9	24	17.993 / 17.988	5
High Pressure	1109-014-196	1/4" NPT Axial	53	132	1/4" NPT	5/8"-18 UNF LH	34	11	9	24	0.6555" / 0.6553"	5
	1109-024-212	G 1/4" Axial	53	129	G 1/4"	M16 x 1.5 LH	31	11	9	24	17.993 / 17.988	5
	1109-044-212	1/4" PT Axial	53	129	1/4" PT	M16 x 1.5 LH	31	11	9	24	17.993 / 17.988	5
	1109-013-196	1/4" NPT Radial	53	138	1/4" NPT	5/8"-18 UNF LH	34	11	9	24	0.6555" / 0.6553"	5
	1109-023-212	G 1/4" Radial	53	135	G 1/4"	M16 x 1.5 LH	31	11	9	24	17.993 / 17.988	5
	1109-043-212	1/4" PT Radial	53	135	1/4" PT	M16 x 1.5 LH	31	11	9	24	17.993 / 17.988	5

*Metric

Axial Connection

Radial Connection

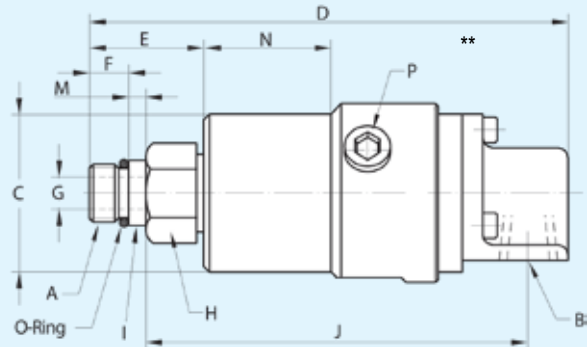
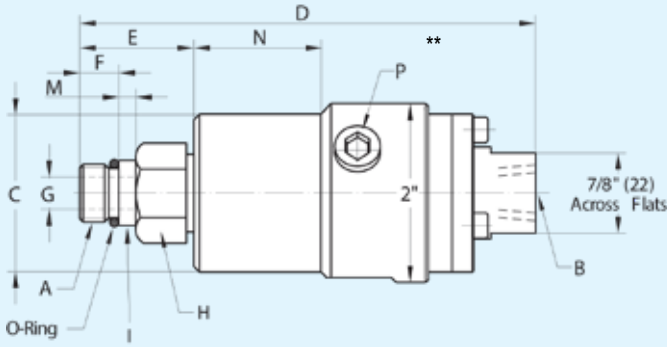

	B Port	Ordering Number	A Rotor Thread	C Dia.	D	E	F	G Rotor Hole	H* Across Flats	I Pilot Dia.	J	M	N	P 3 x 120°	Shpg. Wt.
AXIAL	3/8" NPT	902-111-165	5/8"-18 UNF LH	1.723" 1.722"	5 1/32"	1 13/32"	7/16"	1 1/2"	24	.6555" .6553"	-	3/16"	1 1/2"	1/4" NPT	1 1/2#
	G 3/8" (BSP)	902-121-188	M16 x 1.5 LH	43.760 43.735	129	32	11	9	24	17.993 17.988	-	5	38	G 1/4" (BSP)	.6 Kg

RADIAL

*Metric. **Two of the three tapped holes are to be plugged. The third tapped hole is to be used as drain at 6 o'clock position.

Deublin Coolant Unions Installation

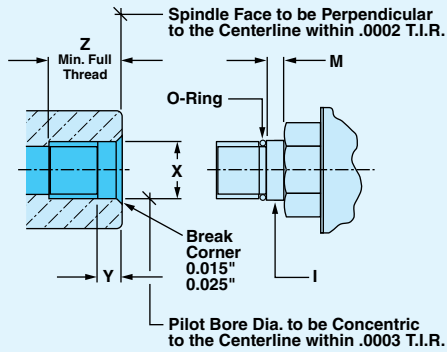

Rotor Pilot		Spindle End		
I	M	X	Y	Z
6555"	3/16"	.6560"	9/32"	13/16"
6553"		.6556"		
17.993	5	18.000	7	17
17.988		17.995		

Installation Instructions:

DEUBLIN Coolant Unions are manufactured to precise tolerances for smooth running without vibration or wobble. A critical factor is the accuracy of the spindle end to which the rotor connects. The interface must adhere to the DEUBLIN specifications.

Attention!

To prevent flooding of bearings, ensure that the drain is continuously sloping downward. Please refer to "Instructions of Hose Installation" on page 54.

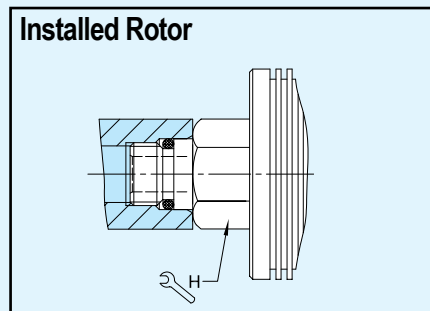
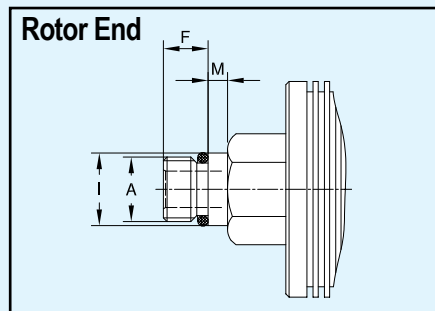

Unions for Special Applications

Model 1005-113-063 1/8" NPT, R.H. Rotor Threads

Model 1005-113-110 5/16"-24 UNF, R.H. Rotor Threads

1/8" Capacity

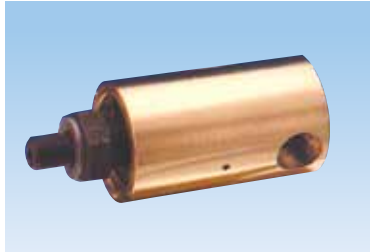

for water service

Operating Data

Max. Water Pressure	750 PSI	52 bar
Max. Speed NPT	1,500 RPM	1,500/min
Max. Speed		
Straight Thread	3,500 RPM	3,500/min
Maximum Temp.	250°F	120°C

This is a small union designed for minimum water flow where space is a problem. The seals are Carbon Graphite-to-Stainless Steel. It has the same dimensions as Model 1005-020-038 on page 32.

Model 468-250 Flanged Rotor

1/4" x 3/8" x 3/8" Capacity

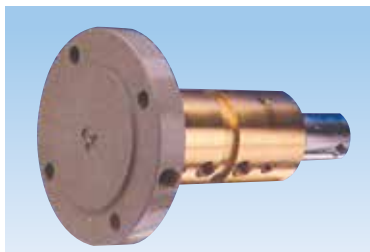

for clutch and brake service

Operating Data

Max. Water Pressure	150 PSI	10 bar
Max. Air Pressure	150 PSI	10 bar
Max. Speed	1,500 RPM	1,500/min
Maximum Temp.	250°F	120°C

This 3-passage union was designed to cool and activate clutches and brakes. The (2) 3/8" water passages supply and return water for cooling. The 1/4" capacity air union is tandem mounted to prevent interpassage leakage between the air and water passages. Contact Deublin Engineering Department for complete specifications.

Model 981-300 2"-12 UN R.H. Rotor Threads

1/2" x 1" Capacity



for oil rig service

Operating Data

Max. Water Pressure	150 PSI	10 bar
Max. Air Pressure	150 PSI	10 bar
Max. Hyd. Pressure	500 PSI	33.3 bar
Max. Speed	350 RPM	350/min
Maximum Temp.	250°F	120°C

This 2-passage union was designed to cool and actuate Drum Brakes on Oil Rigs. It has a 1" water and 1/2" air passage. The water passage has a cartridge seal that can be repaired on the machine. The 981-300 union can also be used on many other Air/Hydraulic applications. Contact Deublin Engineering Department for complete specifications.

For Central Tire Inflation Systems (CTIS)

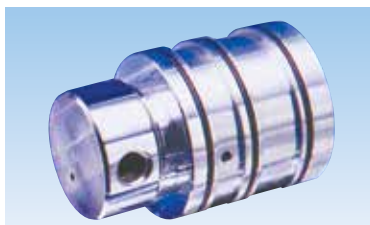

Model 882, 2-passage union. 1/8" pilot capacity and 5/16" supply air capacity. Operating data: Maximum air pressure 150 psi, max temperature 250°F, max speed 450 RPM. This 2-passage model was designed to be used where a wheel valve is required. The O-Ringed union body can be installed in the solid axle and air lines connected to the rotor head.

Deublin has developed a number of hub-mounted unions specifically designed to accommodate the passage of air between a vehicle's stationary axles and its wheels. This allows tire pressure to be varied from inside the vehicle's cab, and is already very popular in the logging industry and on military vehicles. The ability to vary the air pressure allows the driver to adjust pressure for the surface being traveled. Lower pressure with a broader footprint is suitable for soft terrain. Higher pressures and a smaller footprint is suitable for higher speed highway travel.

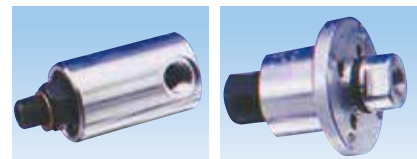

Model 1115-000-001. 11/32" capacity, maximum pressure 150 psi, max temperature 250°F, maximum speed 3,500 RPM. This model union is most commonly used when converting a vehicle to the CTIS system. The male thread can be attached to the solid axle and the supply air from the body to the tire. Shaft mounted conversions of this design are available, and illustrated on Page 34.

Model 1102-025-001-004. 1/4" capacity. Operating data 150 psi, max temperature 250°F, maximum speed 3,500 RPM. The 1102 can be partially mounted within the shaft by using the four holes in the flange, which reduces the overhanging length. The 1102 is not shown, however an in-shaft version is illustrated on Page 34.

DEUBLIN Around-The-Shaft Unions for Air or Hydraulic Service

- Single or multi-passage
- "Controlled leakage" can be vented or channeled to reservoir
- Available for shafts up to 8"
- Capable of handling high speed and pressure
- Custom designed for specific application

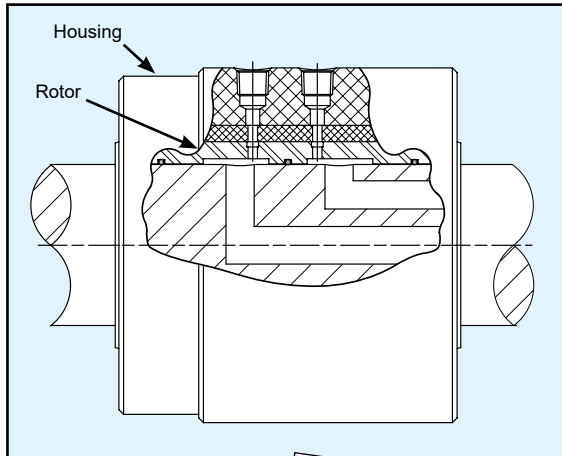

Deublin Rotating Unions for Continuous Casting Machines in the Steel Industry

Deublin has been a major supplier to the steel industry for over 45 years and has worked closely with the people who design, manufacture and operate Continuous Casting Equipment worldwide. We have a separate catalog which features the 2400 Series. With its dependable, long-wearing mechanical seals, the 2400 Series can change the way you think about rotating union maintenance.



Deublin-Sint Steam Joints and Siphon Systems for the Paper Making Industry

Deublin has a complete line of steam inducing and condensate removal products designed specifically for the papermaking industry. These products are contained in a dedicated catalog. This line features the revolutionary FS Series Steam Joint with the Deltasint Stationary Siphon System designed and proven for today's high-speed paper machine's dryer sections.



Deublin Rotating Unions for Coolant Applications

Whether CNC machining centers or automotive transfer lines, Deublin offers the broadest range of rotating union solutions for continuous through-the-spindle coolant applications. State-of-the-art features include silicon carbide seals, and dry running capability with or without pressure.



Flexible Hose Installation Instructions for DEUBLIN Rotating Unions



1 Mount housing in a bench vise and install hose.



2 Install rotating union into machine.



3 Connect flexible hose to supply line.

Examples of Flexible Hose Installation

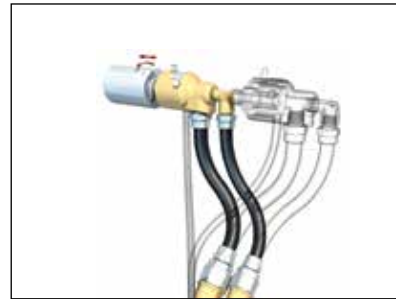

Important

The DEUBLIN ROTATING UNION is a precision-made piece of equipment and should be handled accordingly. It is a rotating sealing device – not just a plumbing union. Improper use could result in premature leakage or failure. While Deublin Unions are of the highest quality and precision, they are "wear and tear" items. It is important that they are periodically inspected and, as seals wear out, the rotating union must be replaced or repaired to avoid the consequence of leakage.

Deublin Unions should never be used for applications other than specified in the catalog. For applications other than stated in the catalog, Deublin Engineering Department should be contacted for recommendations.

These instructions are provided by Deublin as general guidelines. They do not contain exhaustive information about the installation,

use or maintenance of unions. Purchasers and users of Deublin Unions should be certain that they have reviewed Deublin's catalog and have sufficient experience and training in the use of unions before attempting installation or use of Deublin's products. The principal responsibility for the safe and effective use of Deublin Unions rests with the user and its employees. Deublin will provide, upon request, whatever assistance it can to advise users about the use of its products and about any difficulties or problems which are brought to its attention.

WARNING

DEUBLIN unions should not be used to convey flammable media (flash point $\leq 140^{\circ}\text{F}$ or 60°C) as leakage may result in explosions or fires. DEUBLIN unions should be used in accordance with standard safety guidelines for the media, and in a well-ventilated area. The use of our product on hazardous or corrosive media is strictly forbidden.

Factory Testing

All DEUBLIN ROTATING UNIONS are factory tested under pressure before shipment. This thorough check assures that each Deublin Union is completely leakproof.

Deublin Rotating Unions can be installed with fullest confidence that it will operate to your complete satisfaction.

Warranty

For a period of one year from the date of shipment, Deublin warrants that the products sold by it are free from defects in material and workmanship. The liability of Deublin is expressly limited to the replacement or rebuilding of any article, or part thereof, proven defective, when returned to the Deublin Company, transportation prepaid within a reasonable time after the termination of the 365-day warranty period.

This warranty is void if the product is dismantled, modified, altered, or damaged from improper maintenance, side-loading, excessive temperature, abrasive or chemical action, or other abuse.

No representative, agent or employee of Deublin has any authority to modify the terms of this warranty. Deublin will not be responsible for any consequential or resulting damage which may be claimed to have occurred through the sale or use of such products or parts, thereof, which might be defective.

There are no warranties which extend beyond the description contained under this heading, express or implied, including warranties of fitness for a particular purpose.

Repair Service

All Deublin rotating unions can be returned to the factory for professional rebuilding. Unions are refurbished to an "as new" condition and carry a New Union Warranty to ensure optimum performance. Contact Deublin Customer Service to arrange repair service.

Unions can be field serviced with rebuilding kits, which are available for most Deublin rotating unions. These kits include seals, rotors and ball bearings. Where field service is essential, Deublin Cartridge Water Unions or 57 Series should be specified.

Installation

No exterior bracing should be used to prevent the housing of a ball bearing type union from rotating. To compensate for any eccentricities occurring from installation, it is imperative that a flexible connection be used. DO NOT PIPE SOLID. Use a 45-degree elbow and pipe union on the riser, making certain there is a slight curve in the hose. Do not install hose taut.

Relubrication

Model	Amount of Grease (oz.)
55	.12
155	.20
255	.35
355	.35
525	.42
555	.64
655	.64
755	1.50
6200	.64
6250	1.50
6300	2.40
6400	3.20

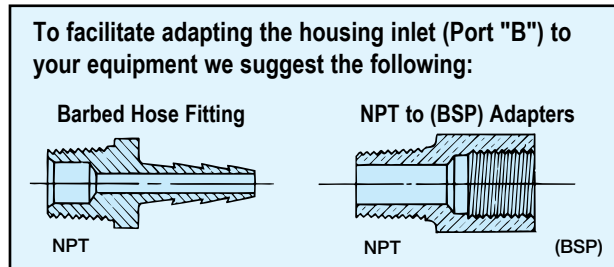

For catalog models with grease fittings, use Chevron SRI 2.

Relubrication Interval

Light Service

Temperatures up to 165°F
little, if any, vibration or moisture (humidity)

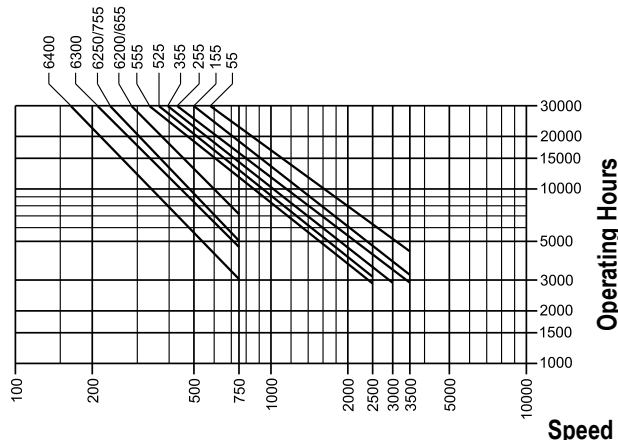

Moderate Service

Temperatures 165°F – 250°F
some vibration and moisture present

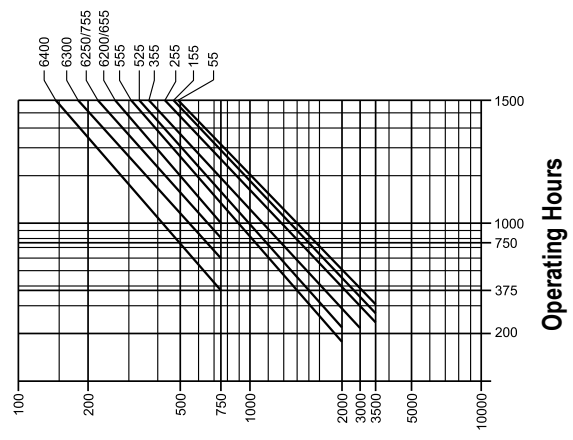

Since its founding in 1945 as a small, family-owned business, Deublin consistently has adhered to a policy of designing and building the best products of their kind in the world. The result of this policy has been constant growth through the years, and for this we are grateful to our many loyal customers.

Today, Deublin is the world's largest manufacturer of rotating unions, with state-of-the-art factories, technical sales and service, and local stocking in 15 countries on four continents, as well as a worldwide distribution network operating from more than 60 countries. Our global organization and extensive catalog of field-tested products ensure a precise match between each customer's requirements and an engineered solution.

We cordially invite you to visit our modern manufacturing facilities in Waukegan, Illinois, USA; Mainz, Germany; Monteveglio, Italy; Dalian, China; and Sao Paulo, Brazil.



Global Headquarters in Waukegan, Illinois, U.S.A.



Mainz, Germany



Monteveglio, Italy



Dalian, China



Deublin products & services are available throughout the world.

www.deublin.com

AMERICAS

DEUBLIN USA

2050 Norman Drive
Waukegan, IL 60085 U.S.A.
Phone: +1 847 689-8600
Fax: +1 847 689-8690
e-mail: cs@deublin.com

DEUBLIN Brazil

Rua Fagundes de Oliveira, 538 - A11 –
Piraporinha
CEP: 09950-300 - Diadema - SP – Brazil
Phone: +55 11-2455-3245
Fax: +55 11-2455-2358
e-mail: deublinbrasil@deublinbrasil.com.br

DEUBLIN Mexico

Norte 79-A No. 77, Col. Claveria
02080 Mexico, D.F.
Phone: +52 55-5342-0362
Fax: +52 55-5342-0157
e-mail: deublinmexicocs@deublin.com

ASIA

DEUBLIN China

No. 2, 7th Street, DD Port,
Economic Development Zone, Dalian,
Liaoning Province, 116620, P.R. China
Phone: +86 411-87549678
Fax: +86 411-87549678
e-mail: info@deublin.cn

Room15A07, Wangjiao Plaza
No.175 East Yan'an Road, Huangpu District
Shanghai, 200041, P.R. China
Phone: +86 21-52980791
Fax: +86 21-52980790
e-mail: service@deublin.cn

DEUBLIN Asia Pacific

51 Goldhill Plaza, #17-02
Singapore 308900
Phone: +65 6259-9225
Fax: +65 6259-9723
e-mail: deublin@singnet.com.sg

DEUBLIN Japan

2-13-1, Minamihanayashiki
Kawanishi City 666-0026, Japan
Phone: +81 72-757-0099
Fax: +81 72-757-0120
e-mail: customerservice@deublin.jp

2-4-10-3F Ryogoku
Sumida-Ku, Tokyo 130-0026, Japan
Phone: +81 35-625-0777
Fax: +81 35-625-0888
e-mail: customerservice@deublin.jp

1-9-2-4F Mikawaanjo-cho
Anjo City, Aichi 446-0056, Japan
Phone: +81 566-7361
Fax: +81 566-71-4360
e-mail: customerservice@deublin.jp

DEUBLIN Korea

Star Tower #1003, Sangdaewon-dong 223-25,
Jungwon-gu, Seongnam-si, Gyeonggi-do,
South Korea
Phone: +82-31-8018-5777
Fax: +82-31-8018-5780
e-mail: customerservice@deublin.kr

EUROPE

DEUBLIN Germany

Florenz - Allee 1
55129 Mainz, Germany
Phone: +49 6131-4998-0
Fax: +49 6131-4998-109
e-mail: info@deublin.de

DEUBLIN Italy

Via Guido Rossa, 9
40053 Comune di Valsamoggia (BO), Italy
Phone: +39 051-835611
Fax: +39 051-832091
e-mail: info@deublin.it

DEUBLIN Austria

Mitterfeldgasse 3/18/R02
1110 Vienna, Austria
Phone: +43 1-8768450
Fax: +43 1-876845030
e-mail: info@deublin.at

DEUBLIN France

61 bis, Avenue de l'Europe
Z.A.C de la Malnoue
77184 Emerainville, France
Phone: +33 1-64616161
Fax: +33 1-64616364
e-mail: service.client@deublin.fr

DEUBLIN Poland

ul. Bierutowska 57-59
51-317 Wroclaw, Poland
Phone: +48 71-3528152
Fax: +48 71-3276278
e-mail: info@deublin.pl

DEUBLIN Russia

5-ya Sokolnoi gori, 18, bld. 2, office 1
105275, Moscow, Russia
Phone: +7 495 647-14-34
Fax: +7 495 938-89-49
e-mail: info@deublinrussia.ru

DEUBLIN Spain

C/Lola Anglada, 20 local 1,
08228 Terrassa, Spain
Phone: +34 93-2211223
Fax: +34 93-2212093
e-mail: deublin@deublin.es

DEUBLIN United Kingdom

6 Sopwith Park, Royce Close,
West Portway
Andover SP10 3TS, UK
Phone: +44 1264-333355
Fax: +44 1264-333304
e-mail: info@deublin.co.uk