



Transair: Modular Pipe Systems

Installation Manual | December 2020



ENGINEERING YOUR SUCCESS.



OTSEGO, MICHIGAN



TIJUANA, MEXICO



ALBION, INDIANA



LAKEVIEW, MICHIGAN



MESA, ARIZONA

WARNING – USER RESPONSIBILITY

FAILURE OR IMPROPER SELECTION OR IMPROPER USE OF THE PRODUCTS DESCRIBED HEREIN OR RELATED ITEMS CAN CAUSE DEATH, PERSONAL INJURY AND PROPERTY DAMAGE.

This document and other information from Parker-Hannifin Corporation, its subsidiaries and authorized distributors provide product or system options for further investigation by users having technical expertise.

The user, through its own analysis and testing, is solely responsible for making the final selection of the system and components and assuring that all performance, endurance, maintenance, safety and warning requirements of the application are met. The user must analyze all aspects of the application, follow applicable industry standards, and follow the information concerning the product in the current product catalog and in any other materials provided from Parker or its subsidiaries or authorized distributors.

To the extent that Parker or its subsidiaries or authorized distributors provide component or system options based upon data or specifications provided by the user, the user is responsible for determining that such data and specifications are suitable and sufficient for all applications and reasonably foreseeable uses of the components or systems.

Safe Drinking Water Act

In accordance with 42 USC § 300g-6, parts in this catalog are to be used exclusively for nonpotable services such as manufacturing, industrial processing, irrigation, outdoor watering, or any other uses where the water is not anticipated to be used for human consumption. The only exceptions are parts described explicitly as “low lead” or suitable for potable water.

Table of Contents

Transair Aluminum Sizing Chart.....	4
Transair Stainless Steel Sizing Chart.....	6

Transair Aluminum Installation Guidelines **A2**

Aluminum Pipe	A7
Pipe to Pipe Connectors.....	A11
Quick Assembly Brackets.....	A24
Pressurized System Bracket (Hot Tap).....	A28
Flexible Hose.....	A30
Pipe Hangers.....	A36
Bending Transair® Aluminium Pipe	A39
Commissioning a Transair Aluminum System.....	A41
Calculating Expansion / Contraction.....	A42
Z Dimensions	A46
Transair 316L Drops Installation Process	A48

Transair Stainless Steel Installation Guidelines **B2**

Stainless Steel Pipe.....	B6
Pipe-to-Pipe Connectors for Stainless Steel.....	B9
Connector Connection and Dismantling Process	B10
Drop Brackets	B16
Pipe Hangers.....	B17
Bending Transair® Stainless Steel Pipe	B18
Z Dimensions	B19

Parker Safety Guide **C2**

Parker Transair

With over 20 years of industry experience, Parker Transair offers a complete line of products for your process piping systems.



Aluminum Range

Ranging from 1/2" to 8", Parker Transair offers a complete line of aluminum pipe and fittings for compressed air, vacuum, and inert gas applications.



Stainless Steel Range

Ranging from 3/4" to 4", Parker Transair offers a complete line of stainless steel pipe and fittings for compressed air, vacuum, inert gas, process water, and chemical transfer applications.



316L Drops

Available in 3/4", our 316L stainless steel drops can tie into existing Transair aluminum or stainless steel pipe systems. Ideal for washdown areas that use harsh cleaning chemicals.



Compressor Room Fittings

Developed for pipe routing in tight areas, our line of compressor room fittings simplifies the connections needed to connect compressor room equipment to the distribution system.



Condition Monitoring

Transair Condition Monitoring (TCM) provides 24/7 access to critical information about your compressed air system. Our web based platform puts vital system information in the palm of your hands.



Filters, Regulators, Lubricators, & Lockout Valves

Transair offers point of use Filters, Regulators, and lubricators in single and combination units. We also offer OSHA approved lock out valves for added safety.

Visit www.parker.com/transair or scan the QR Code with your phone's camera to learn more about our products!



Transair Aluminum Sizing Chart

Sizing Chart

Select the Transair® diameter for your application based on required flow against pressure drop. Estimated values: Closed loop system at 100 PSI with 5% pressure drop.

Flow Rate SCFM	Main Ring Length (ft)						Compressor HP
	500	1000	2000	3000	4000	5000	
10	1/2"	1/2"	1/2"	1"	1"	1"	<15
25	1"	1"	1"	1"	1"	1"	
50	1"	1"	1 1/2"	1 1/2"	1 1/2"	1 1/2"	
75	1"	1 1/2"	1 1/2"	1 1/2"	1 1/2"	1 1/2"	15 to 40
100	1 1/2"	1 1/2"	1 1/2"	1 1/2"	1 1/2"	1 1/2"	
150	1 1/2"	1 1/2"	1 1/2"	2"	2"	2"	
250	1 1/2"	1 1/2"	2"	2"	2 1/2"	2 1/2"	41 to 125
350	2"	2"	2 1/2"	2 1/2"	2 1/2"	2 1/2"	
500	2 1/2"	2 1/2"	2 1/2"	3"	3"	3"	
750	2 1/2"	2 1/2"	3"	3"	4"	4"	126 to 250
1000	3"	3"	3"	4"	4"	4"	
1250	3"	3"	4"	4"	4"	4"	
1500	4"	4"	4"	4"	4"	4"	125 to 500
1750	4"	4"	4"	4"	4"	4"	
2000	4"	4"	4"	4"	4"	6"	
2250	4"	4"	4"	6"	6"	6"	501 to 1000
2500	6"	6"	6"	6"	6"	6"	
2750	6"	6"	6"	6"	6"	6"	
3000	6"	6"	6"	6"	6"	6"	
3250	6"	6"	6"	6"	6"	6"	
3500	6"	6"	6"	6"	6"	6"	
4000	6"	6"	6"	6"	6"	6"	
4500	6"	6"	6"	6"	6"	6"	1001 to 1400
5000	6"	6"	6"	6"	6"	6"	
5500	6"	6"	6"	6"	6"	6"	



Transair Stainless Steel Sizing Chart

- Select the Transair® diameter for your application, based on required flow against pressure drop.
- Estimated values for a closed loop network, a pressure of 58 psi with less than 10% pressure drop.
- Velocity: 13 ft/s.

ESTIMATED FLOW RATE				EQUIVALENT LENGTH									
				32.8 FT	65.6 FT	98.4 FT	131.2 FT	164 FT	246 FT	328 FT	492 FT	656 FT	984 FT
M3/H	L/S	L/MIN	CFM	10 M	20 M	30 M	40 M	50 M	75 M	100 M	150 M	200 M	300 M
0,5	0,14	8	0,3	22	22	22	22	22	22	22	22	22	28
1	0,28	17	0,6	22*	22*	22*	22*	22*	28	28	28	28	42
2,5	0,69	42	1,5	22*	28*	28*	28*	42	42	42	42	42	42
3,5	0,97	58	2,1	28	28	42	42	42	42	42	42	42	60
5	1,39	83	3	28*	42*	42*	42*	42*	42*	42*	60	60	60
10	2,77	167	6	42*	42*	42*	60*	60*	60*	60*	60*	76	76
15	4,17	250	9	42*	60*	60*	60*	60*	60*	76	76	76	76
20	5,56	333	12	60*	60*	60*	60*	60*	76*	76*	76*	100	100
30	8,33	500	18	60*	60*	76*	76*	76*	76*	100*	100*	100*	100*
40	11,11	667	24	76*	76*	76*	76*	76*	100*	100*	100*	100*	
50	13,89	833	29	76*	76*	76*	100*	100*	100*	100*			
75	20,83	1250	44	100*	100*	100*	100*	100*					
80	22,22	1333	47	100*	100*	100*	100*	100*					
100	27,78	1667	59	100*	100*	100*	100*						

* When designing a process water system, take these results in conjunction with system design best practice. An anti water hammer device is necessary for the protection of highly sensitive equipment.

Transair Aluminum Installation Guidelines

Specifications:

Max Working Pressure	188 PSI from -4° to +140° F (12.9 bar from -20° to +60° C)
	232 PSI from -4° to +113° F (15.9 bar from -20° to +46.1° C)
Vacuum:	99% (29.6" Hg)
Working Temperature	-4° to +140° F (-20° to +60° C)

* Please consult us for higher temperature requirements

Prior to the Installation of a Transair® system, the installer should ensure the installation area complies with all safety and hazard regulations. Transair® can be installed in the compressor room, as well as downstream for the distribution piping system. Transair® flexible hoses can be installed to dampen sources of vibration.

When modifying or repairing a Transair® system, ensure the section of pipe where work will take place has been properly vented prior to beginning modifications.

Only genuine Transair® parts should be used for installation. The use of non-Transair® parts with Transair® parts will result in the 10 year warranty being voided. Refer to the technical data in Transair® Catalog 3515 for proper sizing and selection of components.

Pressurizing the system

Once the Transair® system installation has been completed, and prior to pressurizing the system, the installer should complete all tests, inspections, and compliance checks according to customer requirements, engineering best practices, and building code regulations.

Transair® pipe and hoses

Transair® piping needs to be protected from mechanical impact. All Transair® piping systems should be installed out of reach of fork-lifts and above overhead material handling cranes.

Only use genuine Transair® connectors to connect sections of pipe. Transair® pipe should never be welded, soldered, or glued. Transair® Flexible hoses can be installed to route around obstacles following proper installation guidelines.

Note: In certain situations, Transair® piping can be bent - contact the factory for further information.

Expansion / contraction

Prior to installation, ensure the expansion and contraction of the piping system has been properly calculated. The elongation and retraction of each Transair® line should be calculated according to the information found in this installation guide.

Component assembly

For proper installation of a Transair® System, follow the steps outlined in this document.

When installing Transair® piping, avoid the following

- Installing within a solid mass (concrete, foam, etc)
- Hanging external equipment from Transair® pipe
- Using Transair® for grounding, or conduit for electrical wires.
- Exposing Transair® components to incompatible chemicals.
(Contact the factory for further information)

Compressed Air System Design Best Practices

- When installing a Transair system, ensure you follow all local building code regulations
- To reduce the occurrence of pressure drop, eliminate excessive use of elbows and keep the use bypasses and in-line pipe reductions to a minimum.
- Maintain consistent, high quality compressed air through the use of filtration elements in the compressor room and point of use.
- Size the diameter of the pipe according to the required flow rate and the acceptable pressure drop at the point of use.
- Install air drops as close as possible to the point of use.

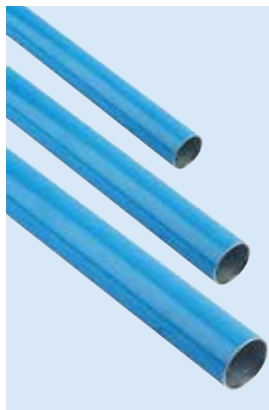

1/2" (16.5mm)
1" (25mm)
1-1/2" (40mm)

Deburred and chamfered pipe



2" (50 mm)
2-1/2" (63 mm)

Pipe pre-drilled at each end with two 1" (25 mm) diameter holes, deburred and chamfered



3" (76mm)
4" (101mm)
6" (168mm)

Pipe lugged at each end, deburred and chamfered

General Information

Transair aluminum pipe is supplied from the factory ready to use. When installing factory lengths of pipe, no cutting, deburring, chamfering is required.

The rigidity of Transair aluminum pipe greatly reduces the occurrence of temperature related expansion and contraction. Due to the rigidity, Transair pipe will not deform overtime and introduce a new area of pressure drop in the system.

Transair components are manufactured within a high tolerance, to ensure a tight fit between the pipe and the connector. As the connection is made, the seal engages to minimize the chance of corrosion on the internal surfaces.

The exterior of all Transair aluminum pipes are coated with a Qualicoat certified protective powder coating. This coating helps to protect the pipe from external corrosion. Transair comes standard in Blue (Compressed Air), Gray (Vacuum) and Green (Industrial / Inert Gases) for system identification and aesthetic appearance.

Standard colors available:

- Blue (RAL 5012/bs1710)
- Gray (RAL 7001)
- Green (RAL 6029)

(Please contact us for other colors)

Transair® aluminum pipe is available in seven diameters from 1/2" to 6".

Applications

Transair® 1/2" to 6" aluminum pipe has been specially designed for compressed air, vacuum and inert gases (argon, nitrogen) – please contact us for other fluids.

Marking

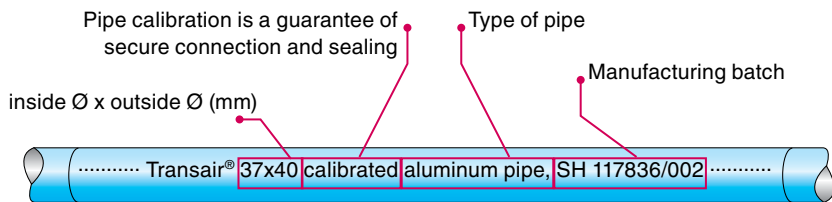

The transported fluid can be instantly identified by the color of the pipe

- ex: Blue pipe → compressed air system
- ex: Gray pipe → vacuum system
- ex: Green pipe → inert gas system

Connection indicator

Only on 1/2" to 1 1/2" aluminum pipe

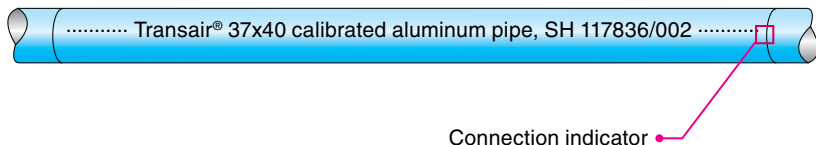

Drilling locator: mark lines for correct drilling

Only on 1/2" to 2 1/2" aluminum pipe



Drilling locators are used to correctly position Transair® brackets onto the pipe. There are two locators on each pipe. The second locator is used to position a second bracket perpendicular to a first bracket.

Aluminum Pipe

1/2" to 1-1/2"

Tools



Pipe cutter for aluminum pipe
ref. 6698 03 01



Chamfer tool for aluminum pipe
ref. 6698 04 01



Deburring tool for aluminum pipe
ref. 6698 04 02



Marking tool for aluminum pipe
ref. 6698 04 03

Pipe Preparation Process

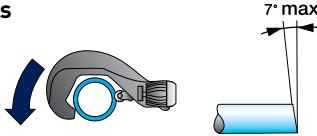

1. Cutting the pipe: Position the blade of the cutter on the pipe, then rotate the pipe cutter around the pipe, gently tightening the blade wheel after each pass.

Note: The cutter cannot be more than 7 degrees off of square while cutting.

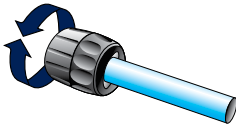

2. Carefully chamfer the outer edges



3. Deburr the inner edge of the pipe

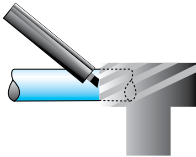

4. Place the marking tool on the end of the pipe, and mark the insertion depth

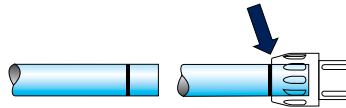

5. Insert the pipe into the connector until the marking meets the edge of the connector

Insertion Depths	1/2		1		1-1/2	
	INSERTION DEPTH (IN)	INSERTION DEPTH (MM)	INSERTION DEPTH (IN)	INSERTION DEPTH (MM)	INSERTION DEPTH (IN)	INSERTION DEPTH (MM)
CONNECTORS	0.98	25	1.06	27	1.77	45
END CAPS	1.54	39	1.65	42	2.52	64

2" to 2-1/2"

Tools



Pipe cutter for aluminum pipe ref. 6698 03 01



File



Deburring tool for aluminum pipe ref. 6698 04 02



Drilling jig for aluminum pipe ref. 6698 01 02



Drilling tool for aluminum pipe ref. 6698 02 01

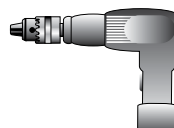

Drill

Pipe Preparation Process

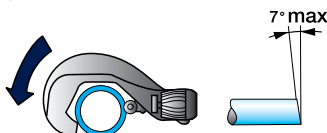

1. Cutting the pipe: Position the blade of the cutter on the pipe, then rotate the pipe cutter around the pipe, gently tightening the blade wheel after each pass.

Note: The cutter cannot be more than 7 degrees off of square while cutting

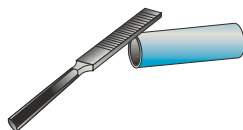

2. Carefully deburr the outer edges



3. Deburr the inner edge of the pipe

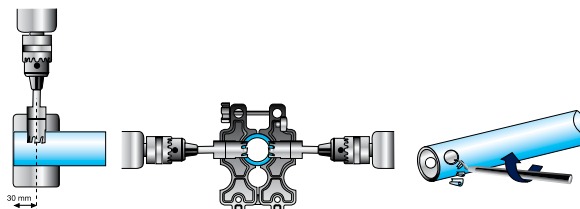

4. Drill the two clamp holes using the drilling jig (6698 01 03) and the 1" drilling tool (6698 02 01). Loosen the jig, release the pipe, then deburr both holes. Ensure that all outer and inner surfaces are smooth and clear of burrs and sharp edges.

3" to 6"

Tools



Pipe cutter for aluminum pipe ref. 6698 03 01 (3") or EW08 00 03 (4" - 6")



File



Deburring tool ref. 6698 04 02



Portable tool kit ref. EW01 00 02



Pipe forming jaw set ref. EW02 L1 00 (3") or EW02 L3 00 (4") or EW02 L8 00 (6")

Pipe Preparation Process



1. Cutting the pipe: Position the blade of the cutter on the pipe, then rotate the pipe cutter around the pipe, gently tightening the blade wheel after each pass.

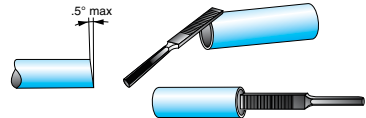

2. Carefully deburr the outer and inner edges of the pipe

Note: The cutter cannot be more than 0.5 degrees off of square while cutting

3. Creating the lugs for 3", 4" or 6" cut pipe



a. Open the retaining pin at the front of the machine by pressing the jaw release button



b. Place the jaw in the housing



c. Lock into position by closing the retaining pin

Procedure



Manually open the jaw and insert the aluminum pipe until the pipe meets the stop in the jaw.



Release the jaw then press the trigger and lug the pipe until a "snap" is heard.





Re-open the jaw to remove the pipe. Position the end of the jaw next to the lug mark: this will help to prevent overlapping the lugs.

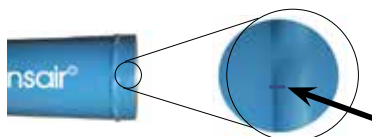

Repeat the operation until the required minimum of lugs for each diameter have been achieved.

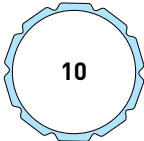

	Ø 3"	Ø 4"	Ø 6"
Minimum. Number of Lugs Important: Do not overlap the lugs!	 5	 6	 10

Pipe to Pipe Connectors

1/2" to 1-1/2"



Instant connection by means of a gripping ring

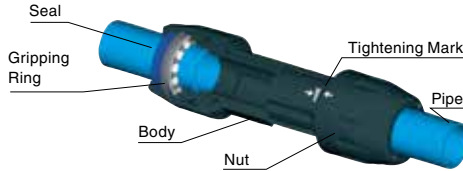

In sizes 1/2" (16,5mm), 1" (25mm), and 1-1/2" (40mm), Transair aluminum pipe uses push to connect technology. Simply push the pipe into the connector until it meets the depth mark on the pipe. The gripping ring will then engage and prevent the pipe from sliding out of the connector.

2" to 2-1/2"



Snap ring quick-fit connection



In sizes 2" (50mm) and 2-1/2" (63mm), Transair aluminum pipe uses snap ring technology. Place the snap ring in the two holes at the end of the pipe and slide the nut in-place. Next, hand tighten the nut into the connector body. Lastly, use a pair of spanner wrenches to fully tighten the connector.

3" to 6"



Clamp quick-fit connection

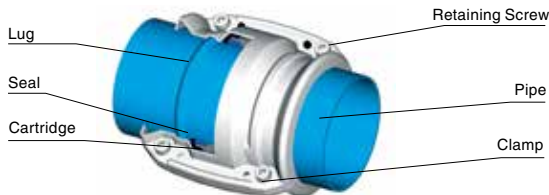

In sizes 3" (76mm), 4" (101mm), and 6" (168mm), Transair aluminum pipe uses clamshell technology. Place the cartridge on the pipe so it meets the lug. Then position the connector so the cartridge is in the middle. Lastly, close the connector and tighten with the provided bolts.

Pre-assembled tightening indicators for 1/2", 1" and 1-1/2" connectors

There are important visual markings on the bodies and nuts of Transair® 1/2", 1" and 1 1/2" connectors. These are represented by solid and empty arrows and indicate the optimum torque. When assembling Transair® connectors, the nuts are tightened to a pre-defined torque on the body of the connector. This torque guarantees the seal and safety of each connection.

Before using 1/2", 1" or 1 1/2" connectors, ensure that the arrow marks are correctly aligned with each other.

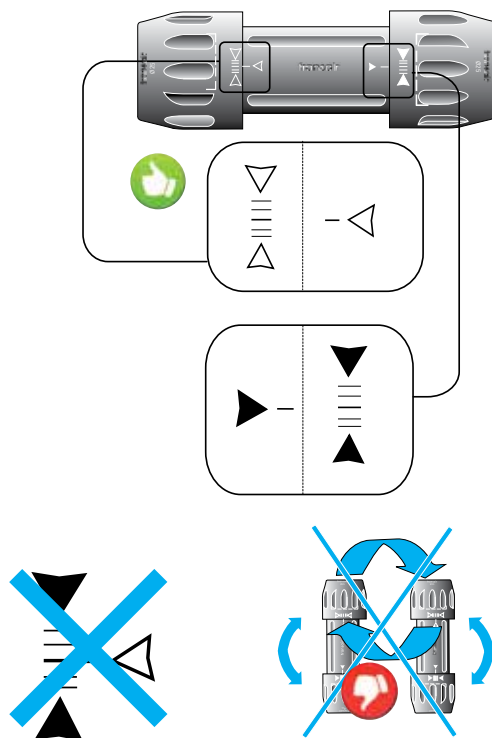

There is no need to loosen the nut on 1/2", 1", and 1-1/2" connectors prior to connecting to Transair aluminum pipe.

Do not switch the nuts. The arrows on the body and nut should be of the same style. (i.e. filled with filled and outline with outline)

Do not interchange connector nuts with other connectors.
All connectors come from the factory pre-torqued for instant installation.

1/2" to 1-1/2"

Connection

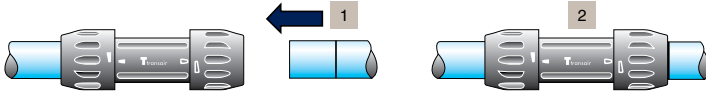

1. Place the marking tool on the end of the pipe, and mark the insertion depth
2. Insert the pipe into the connector until the marking meets the edge of the connector

Disconnection

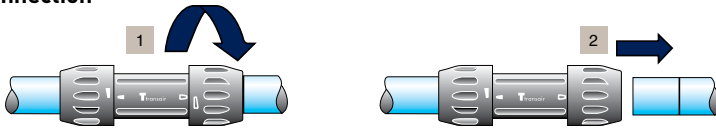

3. Unscrew the nut one-half (1/2) turn
4. Pull the pipe out from the nut

Lateral dismantling: see page A22 of this catalog.

Insertion Depths	1/2		1		1-1/2	
	INSERTION DEPTH (IN)	INSERTION DEPTH (MM)	INSERTION DEPTH (IN)	INSERTION DEPTH (MM)	INSERTION DEPTH (IN)	INSERTION DEPTH (MM)
CONNECTORS	0.98	25	1.06	27	1.77	45
END CAPS	1.54	39	1.65	42	2.52	64

2" to 2-1/2"

Connection

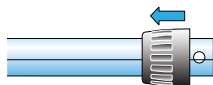

1. Unscrew one of the connector nuts and slide over the pipe

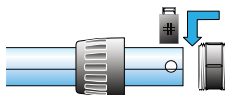

2. Position the snap ring in the appropriate housing (two holes at the end of the pipe)

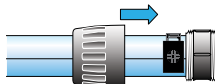

3. Slide the nut that is on the pipe towards the end until it stops against the snap ring.

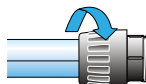

4. Hand tighten the nut

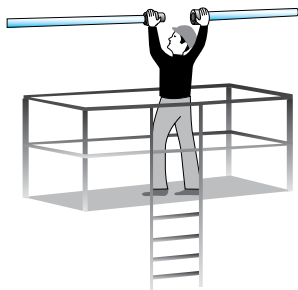

5. Connect the second nut to the connector body

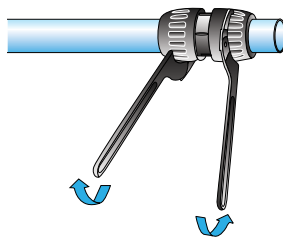

6. Complete the assembly by tightening the connector one-half (1/2) turn with the Transair spanner wrenches

Disconnection

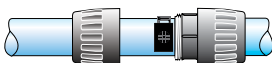
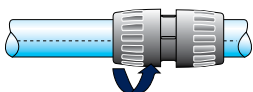

7. To disconnect the connector, perform the same steps, but in reverse order

Lateral dismantling: see page A22 of this catalog.

3" to 6"

Connection

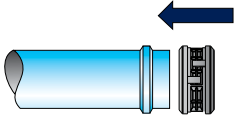

1. Slide the cartridge over the end of the first pipe until it meets the lug

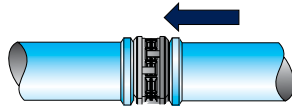

2. Bring the second pipe to the cartridge and slide the the pipe until the cartridge meets the lug

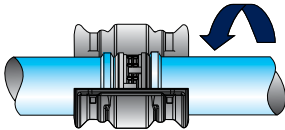

3. Position the clamshell connector over the cartridge / pipe assembly. The cartridge should fall in the middle of the connector

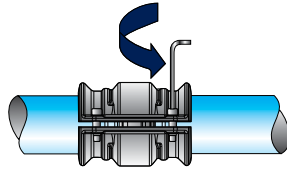

4. Hand-tighten the bolts in a cross pattern with an allen wrench. See chart on the following page for sizes

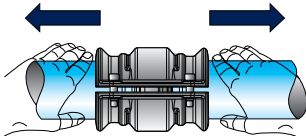

5. Pull the pipes back towards the outside of the clamshell

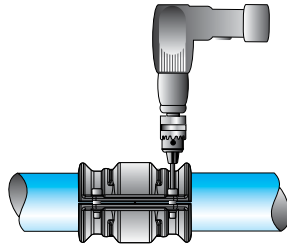

6. Using a drill, fully tighten the clamshell bolts in a cross pattern

Torque Specs: 7.38 lb•ft to 29.5 lb•ft

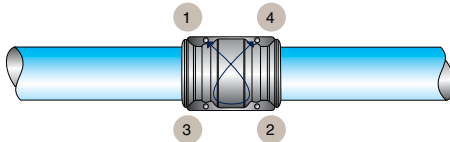

For effective sealing, follow the above diagram for securing the bolts in a cross pattern.

Disconnection

To disconnect the connector, perform the same steps, but in reverse order.



For 6" clamshells only.

Ensure you leave an equal gap (approx: 1/4") on both sides of the clamshell. Over-tightening the bolts can result in an unequal gap which will impact performance.

Allen Wrench Sizes

TRANSAIR DIAMETER	ALLEN WRENCH SIZE
3" (76MM)	6MM
4" (101MM)	6MM
6" (168MM)	8MM

Practical examples — Various 3", 4", and 6" Configurations

Installing a 90° elbow

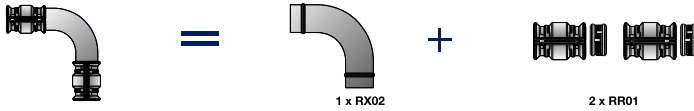

Installing a tee

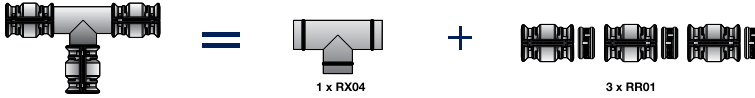

Installing an end cap

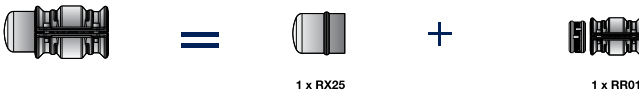

Installing a flange and connector

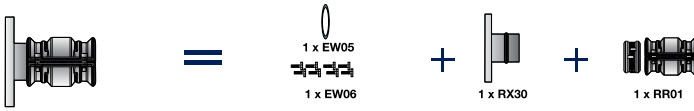

Reducing from 4" to 3"



Installing a butterfly valve

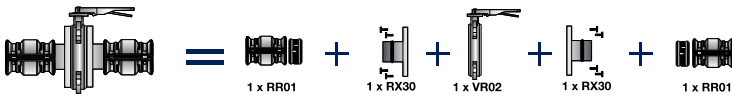

Installing a flange and flexible hose

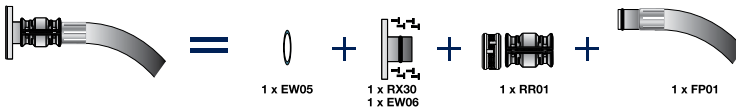

How to close off the 1-1/2" end of a reducing tee



Practical Examples

Connecting a Transair 3", 4", or 6" system to a 2-1/2", 2", 1-1/2", 1", or 1/2" system.

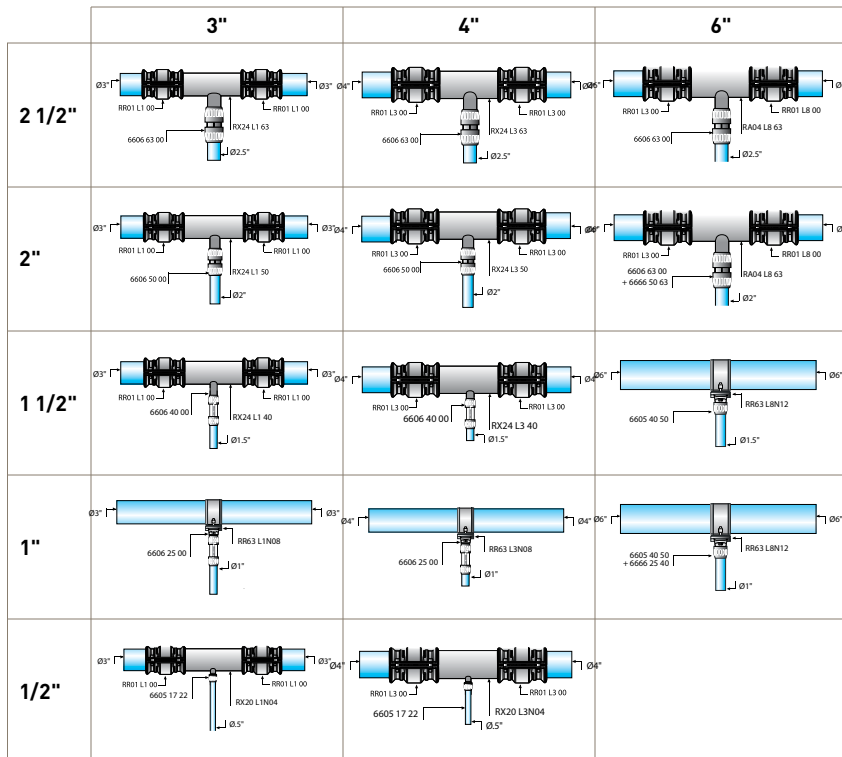

Minimum center to center mounting distances for 3", 4", and 6" tees

ØD1 (IN)	ØD2 (IN)	A (IN)	B MINIMUM (IN)
4	4	3.54	18.5
4	3	3.15	18.5
4	2-1/2	3.54	12.87
4	1-1/2	1.81	8.86
4	1	1.81	8.46
4	1/2	1.81	7.87
3	3	3.15	16.54
3	2-1/2	3.54	12.36
3	1-1/2	1.81	8.35
3	1	1.81	7.95
3	1/2	1.81	7.36

Minimum center to center mounting distances for 3", 4", and 6" drop brackets

ØD1 (IN)	ØD2 (IN)	A (IN)	B MINIMUM (IN)
6	2	3.54	20.08
6	1-1/2	1.81	16.14
4	1	1.81	9.84
3	1	1.81	9.45

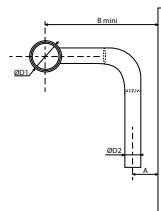

System Modification

Replacing a Union Connector with a Tee Connector

FOR DIAMETERS Ø1/2 - Ø1 - Ø1-1/2 ONLY

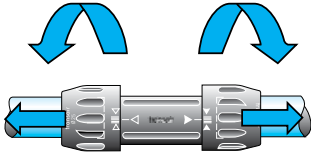

1. Loosen the 2 nuts.



2. Slide them along the pipe on either side of the connector.

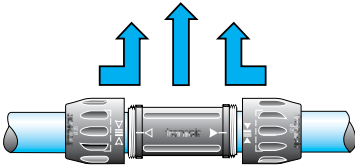

3. Remove the body and nuts of the connector. Re-tighten the nuts onto the body for future use.

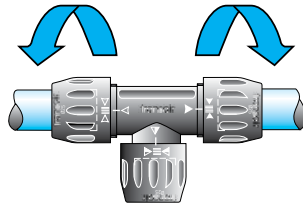

4. Slide the nuts of the tee and position the body of the tee between the 2 pipes such that the solid and empty arrows are facing each other.

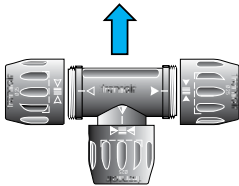

5. Re-tighten the nuts until the empty and solid arrows are aligned with each other.

System Modification

Replacing a Union Connector with a Ball Valve

FOR DIAMETERS Ø1/2 - Ø1 - Ø1-1/2 ONLY

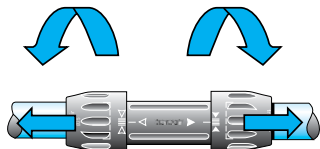

1. Loosen the 2 nuts.



2. Slide them along the pipe on either side of the connector.

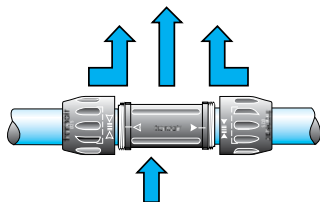

3. Remove the body and nuts of the connector. Re-tighten the nuts onto the body for future use.

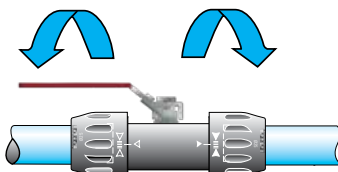

4. Slide the nuts of the valve and position the body of the valve between the 2 pipes so that the empty and solid arrows are facing each other

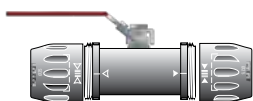

5. Re-tighten the nuts until the empty and solid arrows are aligned with each other.

Lateral dismantling

1/2" to 1-1/2"

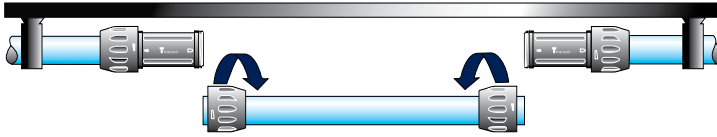

Loosen the nuts on the side of the pipe and slide them away from the connector. Then remove the pipe.

Important: When re-installing the pipe, do not swap the nuts.

2" to 2-1/2"

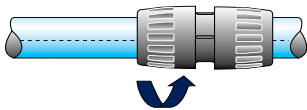

1. Loosen the nuts on the end of the pipe to be removed

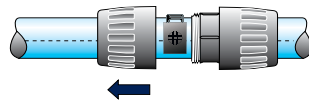

2. Slide the nuts away from the connectors

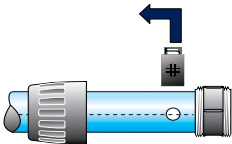

3. Remove the snap rings from their housings

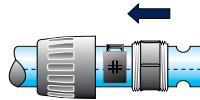

4. Loosen and slide the connector body away from the remaining attached nut

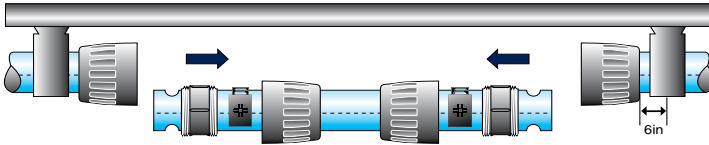

5. Repeat the process at the other end of the pipe and remove the pipe, along with the assembly components.

Transair® 1-1/2" remote shut-off valve

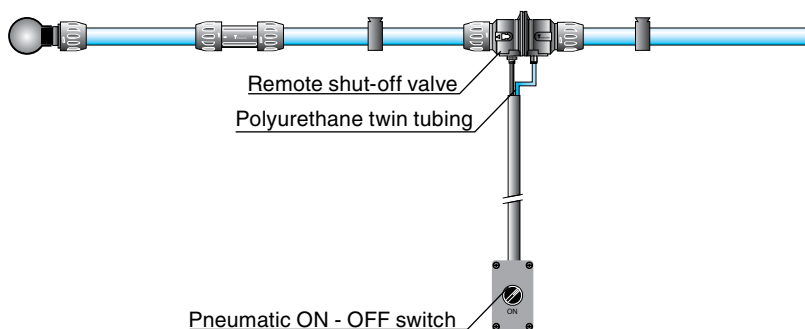

Application

The Transair 1-1/2" remote shut-off valve allows a branch of the system to be opened or closed at ground level or remotely.

The Transair® remote shut-off valve guarantees:

- Personal safety, by eliminating all hazards related to working at heights
- Servicing speed, by removing the need for special access equipment (ladder, platform etc)

Operating principle

Single acting valve - normally closed.

For compressed air systems:

The valve control pressure can be taken upstream of the isolating valve, with no external power supply. Control is performed through the control unit connected to the valve by means of a push-in connector.

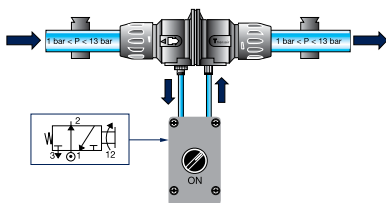

For vacuum systems:

A compressed air supply external to the control unit is required, and the corresponding valve port must be closed in order to prevent loss.

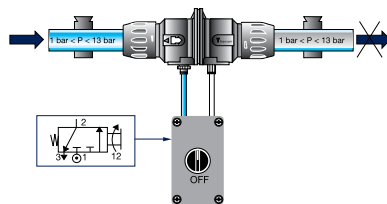

Do's

Connection

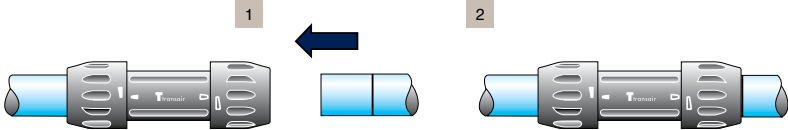

Use a pipe cutter

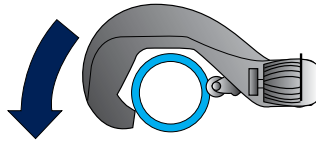

Carefully chamfer and deburr the pipe after cutting or drilling

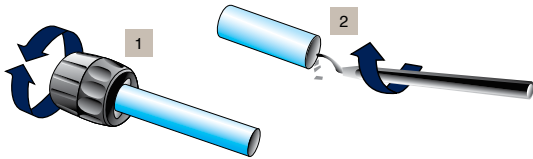

Check that the pipe is correctly positioned in the connector

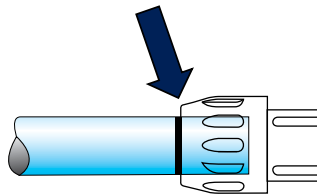

Don'ts

Loosen the nuts during assembly

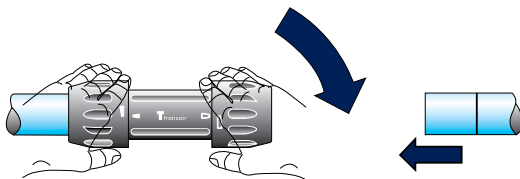

Cut the pipe with a saw

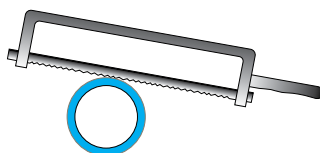

Use non-deburred pipe

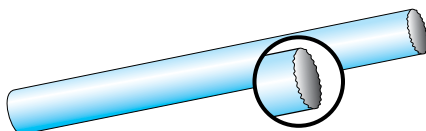

Fail to make the pipe secure

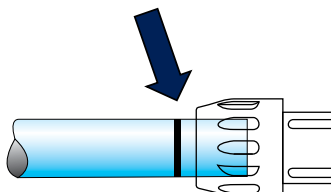

Connect 1-1/2" end cap to reducing tee

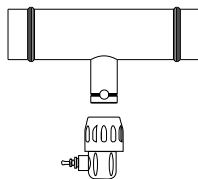

Quick Assembly Brackets

General

The ability to easily add a new drop line on an existing system is an important consideration when selecting a compressed air piping system. Transair® quick assembly brackets are designed for quick and easy installation. These brackets have a "swan neck" design that prevents condensate water from dripping down the drop line. The small footprint of the quick assembly bracket allows for a drop line to be installed in the tightest places. These brackets can be used for vertical drops or horizontal branch lines.

Vertical Drop

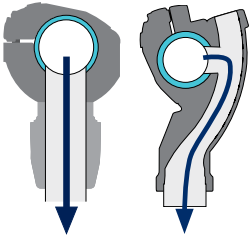

Horizontal Branch Line

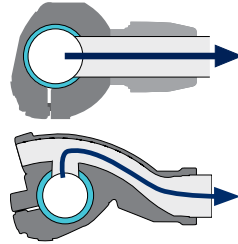

Spacing Guidelines for Quick Assembly Brackets

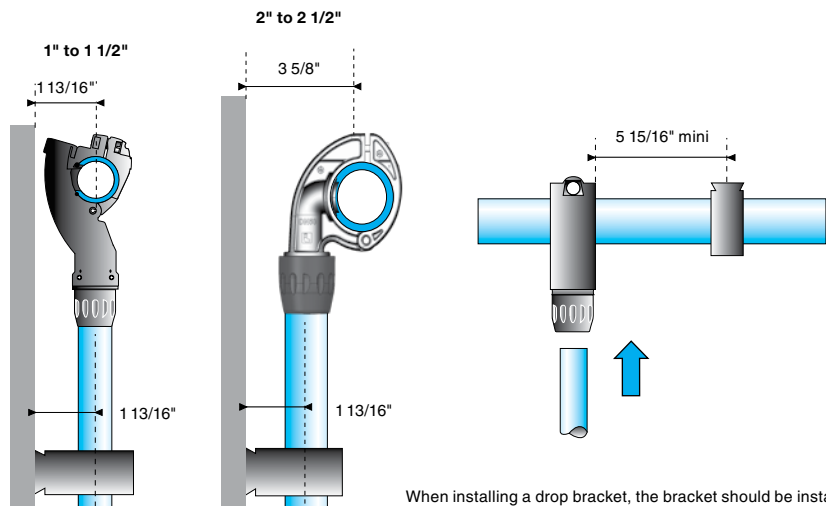

The distance from the center of the pipe to the wall is equal to the center of the bracket to the wall. (i.e. 1 13/16")

The distance from the center of the pipe to the wall is 1 13/16". The distance from the center of the bracket to the wall is 3 5/8"

When installing a drop bracket, the bracket should be installed a minimum of 5 15/16" away from a pipe hanger to allow for expansion / contraction of the pipe.

Installing a quick assembly bracket

To 1", 1-1/2", 2", and 2-1/2"

Tools required

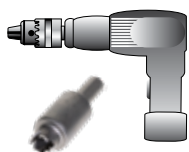

Drilling tool for aluminum pipe
ref. 6698 02 02 or 6698 02 01



Drilling jig for aluminum pipe
ref. 6698 01 01



Deburring tool for
aluminum pipe ref.
6698 04 02



Permanent marker pen



5mm Allen Wrench

Quick Assembly Bracket Installation Process

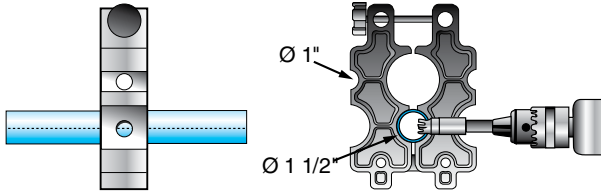

1. Mark the pipe at the desired location, using the dotted line locator marks. These marks will ensure all drop lines off a single piece of pipe will be uniformly aligned. Loosen the retaining bolt on the drilling jig and place it around the pipe. Align your locator mark in-line with the guide hole on the drilling jig. Once the jig is aligned close and tighten the jig. Lastly, place the appropriate drilling tool in your drill and drill the hole.

■ Do not lubricate the drill,

■ Suggested rotation speed: 650 rpm



2. Release the pipe from the jig. Next, remove any chips from the hole. Lastly, deburr the hole to ensure there are no rough edges to cut the seal.

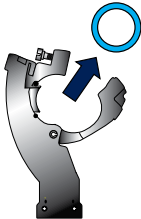

3. Position the quick assembly bracket over the hole. The bracket has a raised plug to fit into the drilled hole.



4. Tighten the screw using a 5mm allen wrench

Installing a bracket

On 3", 4" or 6" pipe

Tools required



Drilling tool for aluminum pipe
ref. EW09 00 30 (3" - 4") or
EW09 00 51 / EW09 00 64 (6")



Deburring tool for aluminum
pipe ref. 6698 04 02

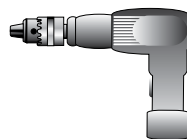

Drill

Drop Bracket Installation Process

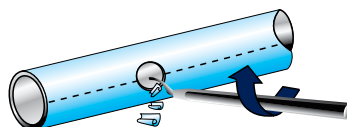
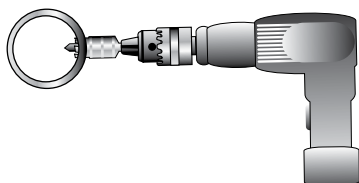

1. Mark the location for the drop bracket. Then using the appropriate drilling tool, drill the hole for the drop bracket.
2. Remove any chips and carefully deburr the hole ensuring no rough edges are left behind.

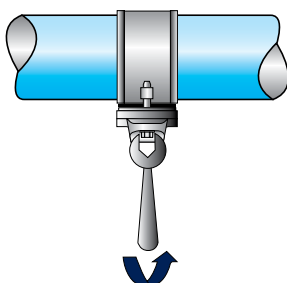

3. Position the plug of the bracket in the hole and tighten the bolts using a crescent wrench

Note: Use adapter ref. 6621 25 35 in combination with bracket ref. RR63 to create a 1" take-off point from 3" or 4" pipe.

Practical examples

Installing Vertical and Horizontal drop brackets

Using the same locator mark



Adding an off-set bracket

Using two locator marks



Common drop bracket Assemblies

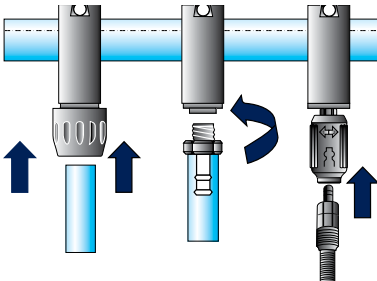

1. Transair pipe connected to push to connect drop bracket
2. Air hose connected to Transair drop bracket with a threaded plug
3. Transair safety coupler w/ quick plug threaded to a drop bracket.

Pressurized System Bracket (Hot Tap)

This drilling tool is used to install a drop bracket to an existing, under-pressure system. This tool easily attaches to a standard drill.

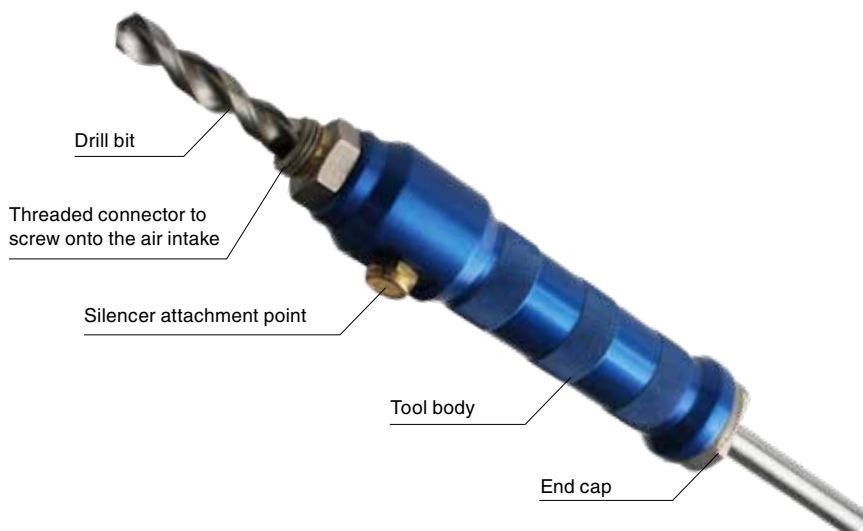

Torque Ratings for Bracket Screws

PART NO.	OD (IN)	OD (MM)	TORQUE RATING (FT-LBS)
EA98 25 04	1	25	5.90 TO 8.85
EA98 40 04	1-1/2	40	5.90 TO 8.85
EA98 50 04	2	50	3.69 TO 7.38
EA98 63 04	2-1/2	63	3.69 TO 7.38

Procedure



1

1. Position the hot tap bracket on the pipe and tighten with the recommended torque rating (see chart below)

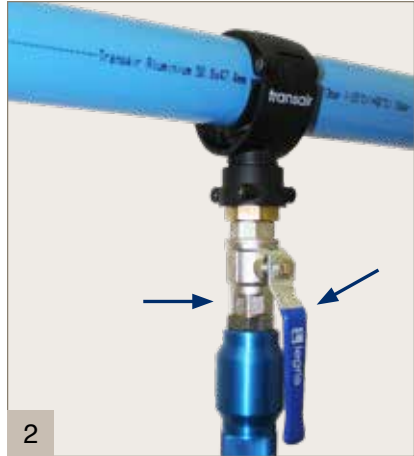

2

2. Thread the drilling tool onto the ball valve. Ensure the valve is open then fully drill the hole.



3

3. Remove the drill and immediately close the ball valve



4

4. Dismantle the tool and remove chips between drillings.

Flexible Hose

General

Transair flexible hoses can easily connect to Transair components and be installed without prior preparation or cutting.

Thanks to the tight bend radius, these hoses require minimum space and does not create mechanical stress on the system. These hoses are resistant to compressor oils as well as fire.

Level change

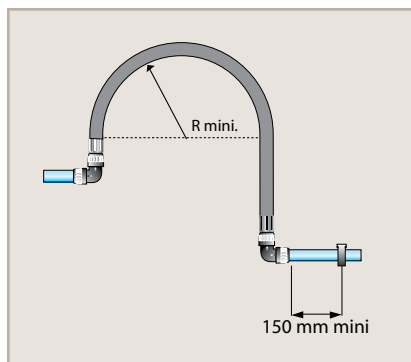

Expansion loop

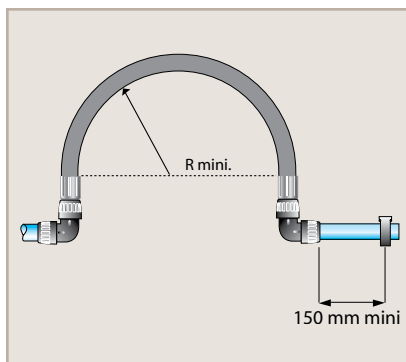

Obstacle bypass

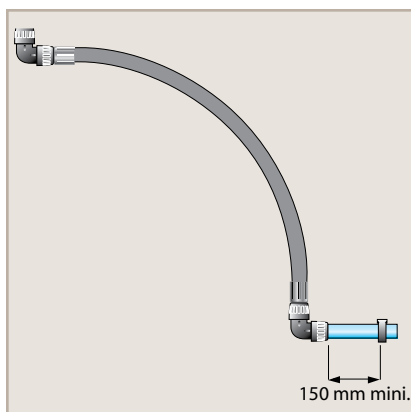

Applications

PART NO.	OD (IN)	OD (MM)	L (FT)	MIN. BEND RADIUS (IN)
1001E25 00 01	1	25	1' 10"	4
1001E25 00 03	1	25	4' 11"	4
1001E25 00 04	1	25	6' 6"	4
1001E40 00 02	1-1/2	40	3' 9"	16
1001E40 00 04	1-1/2	40	6' 6"	16
1001E40 00 05	1-1/2	40	9' 10"	16
1001E50 00 04	2	50	3' 3"	11
1001E50 00 09	2	50	6' 6"	11
1001E63 00 05	2-1/2	63	4' 7"	12
1001E63 00 08	2-1/2	63	9' 10"	25
FP01 L1 01	3	76	4' 11"	14
FP01 L1 02	3	76	6' 6"	14
FP01 L3 02	4	101	6' 6"	20
FP01 L3 03	4	101	9' 10"	20
FX01 L8 02	6	168	10' 6"	35



Safety

Anti-whiplash straps

In order to avoid whiplash accidents, Parker Transair suggests the use of an anti-whiplash strap installed on either side of the connection. (2 straps per hose).

If the hose breaks free of the connection, the strap will prevent the hose from failing around causing personal injury or damage to property. (The straps conform to the ISO 4414 safety standard)

PART NO.	FOR USE WITH TRANSAIR PIPE DIAMETER
6698 99 03	1 TO 4
6698 99 07	6

1" to 1-1/2" Flexible Hose Installation Process

Using a male threaded connector

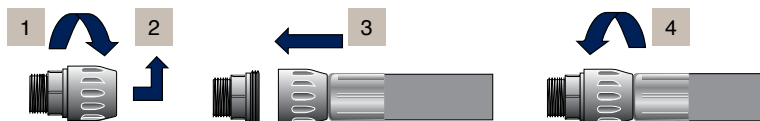

1. Loosen the nut on the threaded male connector
2. Remove the nut
3. Place the end of the hose onto the exposed threads of the male connector
4. Tighten the nut of the hose onto the threads

Using a Union Connector



1. Loosen the nut of the union
2. Remove the nut
3. Place the end of the hose onto the exposed threads of the union
4. Tighten the nut of the hose onto the threads

Using a 90° elbow

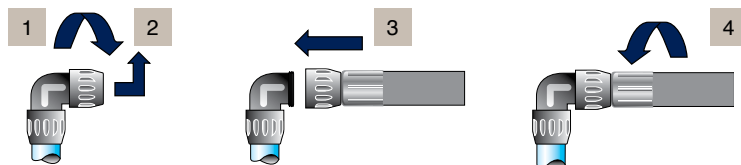

1. Loosen the nut of the elbow
2. Remove the nut
3. Place the end of the hose onto the exposed threads of the elbow
4. Tighten the nut of the hose onto the threads

2" to 2-1/2" Flexible Hose Installation Process

Using a male threaded connector

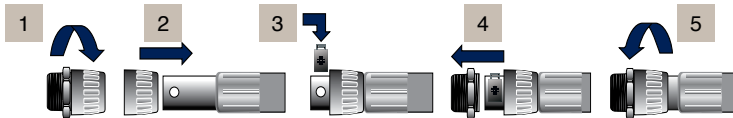

1. Remove the nut on the threaded male connector
2. Place the nut over the end of the flexible hose
3. Place the snap ring in the holes on the end of the hose
4. Thread the nut onto the threads of the connector
5. Tighten the nut one-half (1/2) turn using Transair spanner wrenches

Using a Union Connector

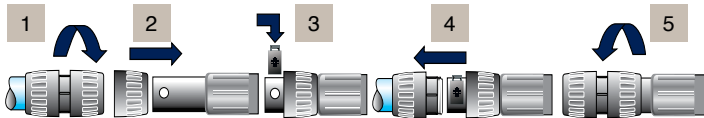

1. Remove the nut on the union connector
2. Place the nut over the end of the flexible hose
3. Place the snap ring in the holes on the end of the hose
4. Thread the nut onto the threads of the connector body
5. Tighten the nut one-half (1/2) turn using Transair spanner wrenches

Using a 90° elbow

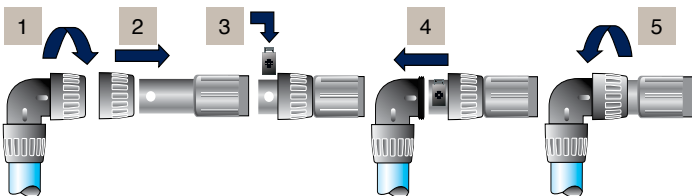

1. Remove the nut on the elbow
2. Place the nut over the end of the flexible hose
3. Place the snap ring in the holes on the end of the hose
4. Thread the nut onto the threads of the elbow body
5. Tighten the nut one-half (1/2) turn using Transair spanner wrenches

3" to 6" Flexible Hose Installation Process

Using a Union Connector

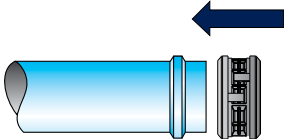
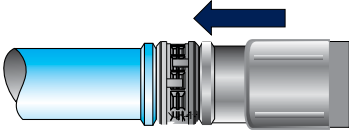
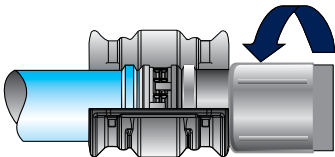
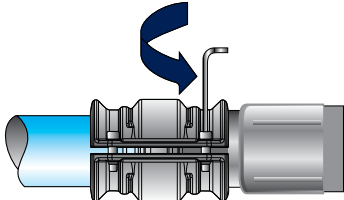
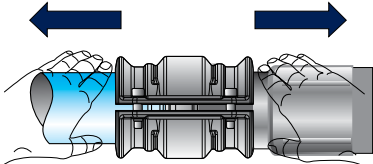
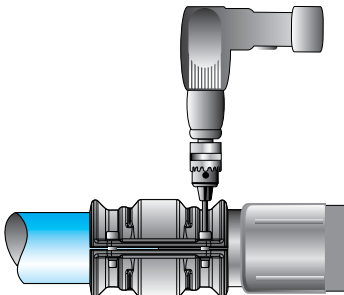
- 
1. Slide the cartridge over the end of the pipe until it meets the lug
- 
2. Bring the end of the hose to the cartridge and slide the end until the cartridge meets the lug of the hose.
- 
3. Position the clamshell connector over the cartridge / pipe assembly. The cartridge should fall in the middle of the connector
- 
4. Hand-tighten the bolts in a cross pattern with an allen wrench. see chart below for sizes)
- 
5. Pull the pipe and hose back towards the outside of the clamshell
- 
6. Using a drill, fully tighten the clamshell bolts in a cross pattern

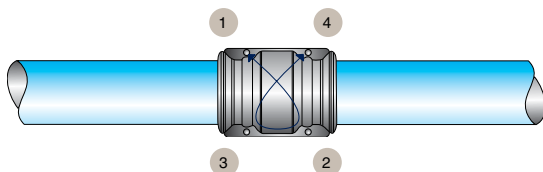





For effective sealing, follow the above diagram for securing the bolts in a cross pattern.

Allen wrench sizes



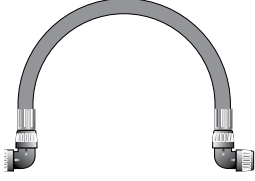

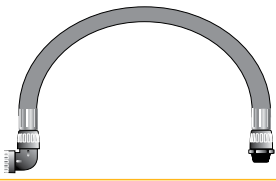
TRANSAIR DIAMETER	ALLEN WRENCH SIZE
3" (76MM)	6MM
4" (101MM)	6MM
6" (168MM)	8MM

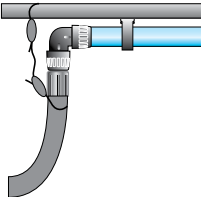
Do's & Dont's

Do

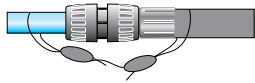
- 
- 
- 
- 
- 
- 

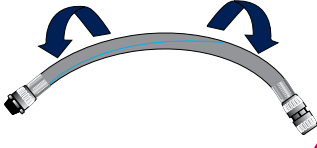
Don't

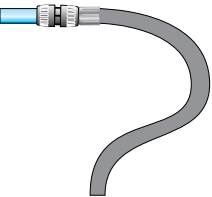
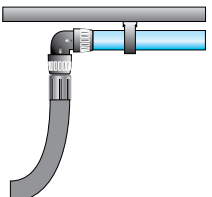
- 
- 
- 
- 
- 
- 

Pipe Hangers

Pipe Hangers for 1/2" to 2-1/2" Transair Aluminum Pipe

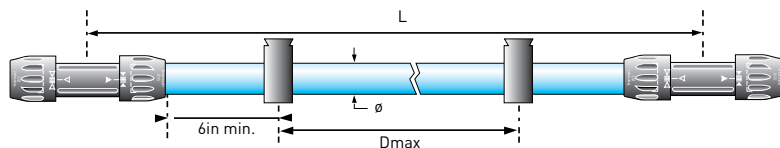

The Transair pipe hanger allows for the expansion and contraction of the pipe to freely occur.

To ensure a stable piping system, Parker Transair suggests the use of at least 2 hangers per pipe. Transair aluminum pipe should only be mounted using genuine Transair pipe hangers.

Ø (IN)	Ø (MM)	PIPE LENGTH (FT)	D _{MAX} (FT)
1/2	16.5	9	8
1/2	16.5	15	10
1	25	9	8
1	25	20	10
1-1/2	40	9	8
1-1/2	40	20	13
2	50	10	8
2	50	20	13
2-1/2	63	10	8
2-1/2	63	20	13

1/2" to 2-1/2" Pipe Hanger Installation Process

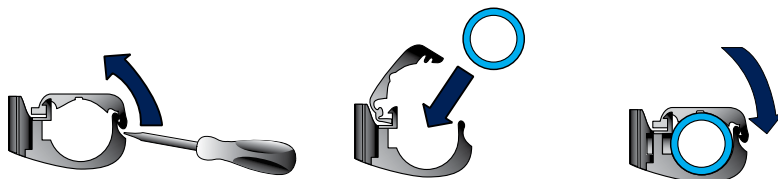

1. Install the pipe hanger where required and open using a screwdriver
2. Insert the pipe into the pipe hanger
3. Close the pipe hanger

Pipe Hanger Quick Facts

- Transair pipe hangers are installed / suspended using 3/8" threaded rod.
- 1/2" to 1-1/2" pipe hangers have a 1/4" female thread
- 2" & 2-1/2" pipe hangers have a 3/8" female thread
- For 1/2" to 1-1/2" hangers, Transair provides an adapter to convert the 1/4" threads to 3/8".

Spacer

The Transair 6697 00 03 spacer is used for fitting a run of Transair using different diameters without introducing a bend.

Example:

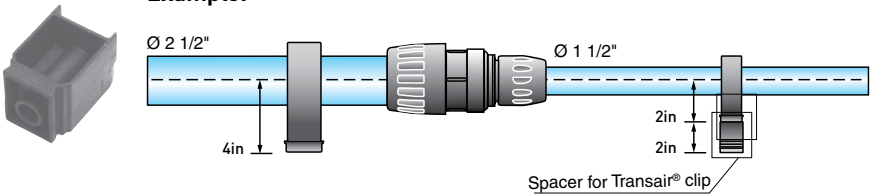

Pipe Hangers for 3" to 6" Transair Aluminum Pipe

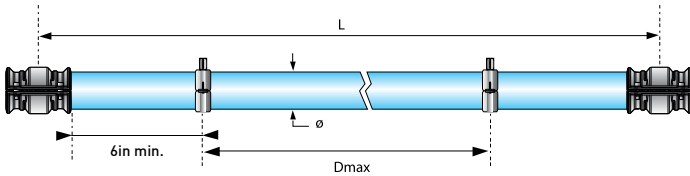

To ensure a stable piping system, Parker Transair suggests the use of at least 2 hangers per pipe. Transair aluminum pipe should only be mounted using genuine Transair pipe hangers.

Ø (IN)	Ø (MM)	PIPE LENGTH (FT)	D_{MAX} (FT)
3	76	20	16
4	101	20	16
6	168	20	16

Supporting a Transair® system

Directly onto a wall

Offset from a wall

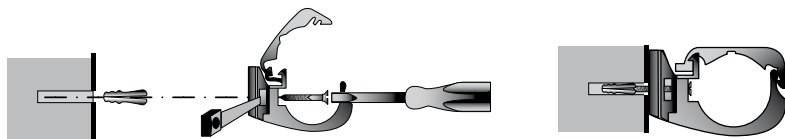

1. Remove the nut at the base of the pipe hanger. Using a screwdriver, insert the screw through the hanger and into the wall. If the hanger does not fall on a stud, use a wall anchor to secure the hanger.
2. Tighten the screw

U-channel type mounting bracket

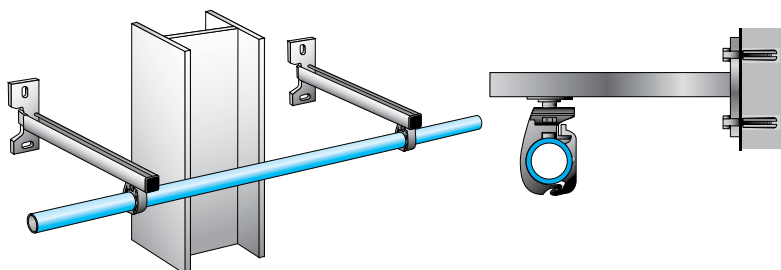

U-channel assemblies are used to offset systems and to bypass obstacles.

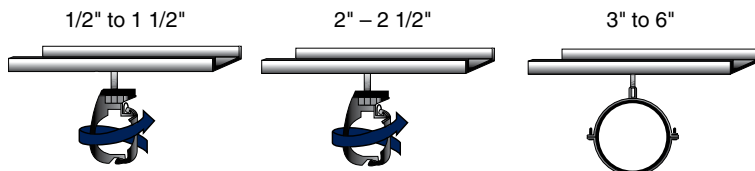

Threaded rod adapter

The Transair® threaded rod adaptor allows 1/2", 1" and 1 1/2" Transair® pipe clips to be easily suspended under 3/8" threaded rod.

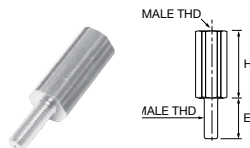

Bending Transair® Aluminium Pipe

All Diameters

Thanks to the material and manufacturing process, all Transair aluminum pipes can be bent to the following specifications:

TRANSAIR®	R MIN. (IN)	L MIN. (IN)
Ø 1/2	4	7.3
Ø 1	6	7.3
Ø 1-1/2	9.8	7.3
Ø 2	11.8	7.3
Ø 2-1/2	15.5	7.3
Ø 3	12.5	7.3
Ø 4	16.7	7.3
Ø 6	27.6	7.3

The above values have been validated in accordance to standard industrial bending techniques.
(For more information on pipe bending, please contact us)

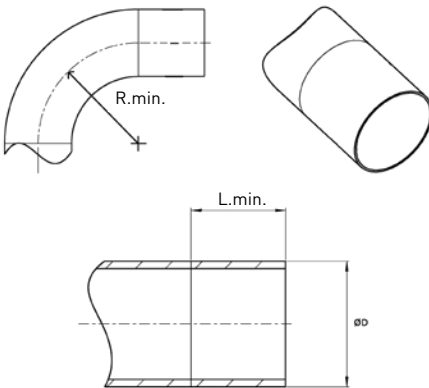



Commissioning a Transair Aluminum System

Step 1: Equipment that is not subjected to the pressure test should be either disconnected from the Transair® piping system or isolated. Valves could be used for isolation provided that the valve closure is suitable for the proposed test pressure.

Step 2: Start the compressor(s) and pressurize at 45psi to check the integrity of the Transair® install and that compressor(s) are running correctly.

Step 3: Leave the system at 45 psi for 12 hours.

Step 4: After 12 hours, check the Transair® system for any pressure drop. If more than 10% pressure drop, compared to discharge pressure, has been lost, inspect the system for weeping or leaks at all joints and connections. Restart the test.

Step 5: Increase the compressor(s) discharge pressure to the system designed working pressure and leave the system at that pressure for a period of 4 hours. If more than 10% pressure drop, compared to discharge pressure, has been lost, inspect the system for weeping or leaks at all joints and connects. Restart the test.

Step 6: Increase the compressor(s) discharge pressure to 1.4X the system designed working pressure. Inspect the Transair® piping system for weeping or leakage.

Step 7: Purge the system and pressurize to designed max operating pressure.

Considerations:

1. If a certification of the Transair® system is required, follow guidelines outlined by ASME B31.1
2. Certificates for manufacturing process quality (i.e. ISO 9001) and product conformity (i.e. CE, Qualicoat, etc.) are available upon request.
3. The Transair® team can also provide BIM (Building Information Modeling) support, system calculations, design consultations, etc.

Pressure tests are not to exceed max working pressure of Transair (188psi for 6" and 232psi for ½ to 4")

For support or copies of our certifications, please contact Transair customer service!

Email: transaircustomerservice@parker.com

Phone: (480) 830-7764



Calculating Expansion / Contraction

L: length of Transair® straight line to be installed (in m)

ΔT : difference between temperature when installing and maximum operating temperature (in °C)

ΔL : line length variation (in mm)

For Transair® 1/2" – 4" aluminum pipe systems:

$$\Delta L = \frac{a \times L}{1} + \frac{0.024 \times L \times \Delta T}{2}$$

1. Expansion related to pipe retraction in the connector
2. Expansion related to temperature variations

	Ø 1/2"	Ø 1"	Ø 1 1/2"	Ø 2"	Ø 2 1/2"	Ø 3"	Ø 4"	Ø 6"
9 FT PIPE	a=0.06	a=0.20	a=0.56	–	–	–	–	–
10 FT PIPE	–	–	–	a=0.56	a=0.73	–	–	–
20 FT PIPE	–	a=0.10	a=0.20	a=0.29	a=0.38	a=0.50	a=0.50	a=0.67

Example

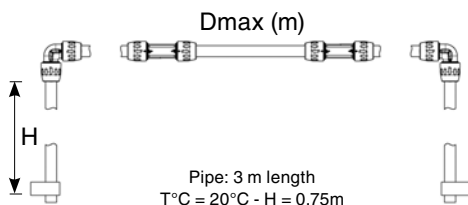

Case no. 1:

Maximum distance, without expansion loop, from a fixed point dependant on Transair® diameter (2 elbows)

Ø TRANSAIR®	1/2	1	1 1/2	2	2 1/2	3	4
DMAX. (M)	50	40	30	24	24	15	15

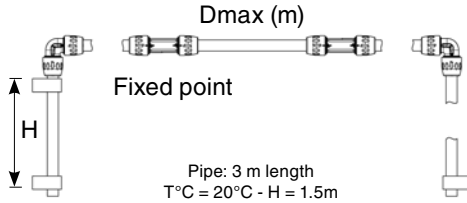

Case no. 2:

Maximum distance, without expansion loop, dependant on Transair® diameter

Ø TRANSAIR®	1/2	1	1 1/2	2	2 1/2	3	4
DMAX. (M)	50	40	30	24	24	15	15

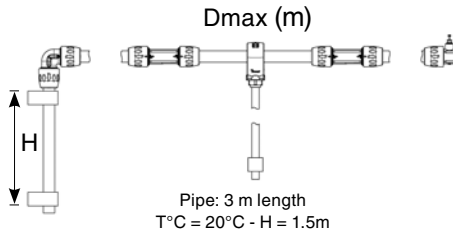

Case no. 3:

Maximum distance for installing a bracket, without expansion loop, dependant on Transair® diameter (1 elbow - 1 bracket)

Ø TRANSAIR®	1/2	1	1 1/2	2	2 1/2	3	4
DMAX. (M)	48	38	30	25	25	7.5	7.5

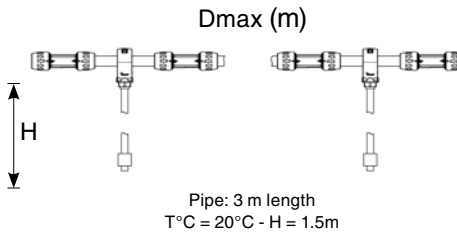

Case no. 4:

Maximum distance for installing a bracket, without expansion loop, dependant on Transair® diameter (2 brackets)

Ø TRANSAIR®	1/2	1	1 1/2	2	2 1/2	3	4
DMAX. (M)	80	70	55	40	40	15	15

Practical Information

Direction change

In addition to expansion loops, changes of direction are another method of compensating for expansion and contraction.

- For Transair® 1/2" to 2 1/2" aluminum pipe systems

$H = 29.5"$ $\Delta L1 = 0.6"$

$H = 59.1"$ $\Delta L1 = 1.2"$

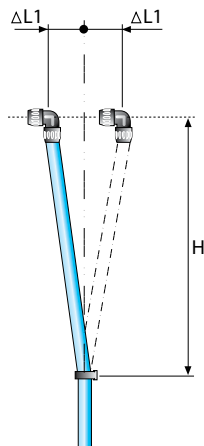

Using an elbow

- For Transair® 3" to 6" aluminum pipe systems

$H = 29.5"$ $\Delta L1 = 3/8"$

$H = 59.1"$ $\Delta L1 = 6/8"$

Using a quick assembly bracket

- For Transair® 1/2" to 2 1/2" aluminum pipe systems

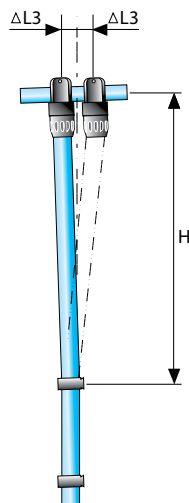
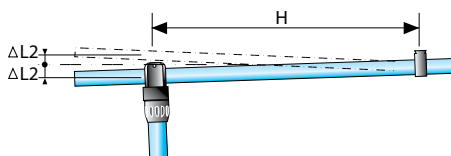

Ø1 (IN)	Ø2 (IN)	H (FT)	ΔL2 (IN)	ΔL3 (IN)
1	1/2	5	1/2	1
1	1	5	1/2	1
1 1/2	1/2	5	1/2	1
1 1/2	1	5	1/2	1
2	1/2	5	1/2	1
2	1	5	1/2	1
2 1/2	1	5	1/2	1

The length variation ΔL , calculated for the Transair® line, must always be equal to or less than $\Delta L2$ and $\Delta L3$. If this is not the case, then an expansion loop, using Transair® flexible hose, must be added.

Practical Information

Expansion / Contraction

Changing direction with a tee

For Transair® 3" - 6" aluminum pipe systems

Ø (IN)	Ø (MM)	H (FT)	ΔL2 MAXI (IN)	ΔL3 MAXI (IN)
3	76	2 1/2	3/8	3/8
4	101	2 1/2	3/8	3/8
6	168	2 1/2	3/8	3/8

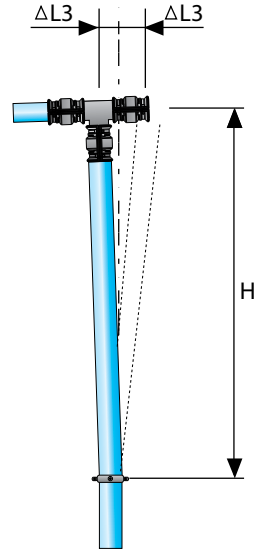
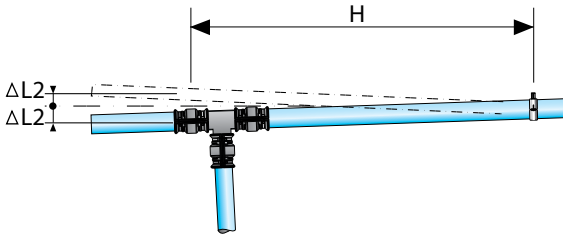

Expansion Loop

$$\Delta L \text{ (in mm)} = H \text{ (in m)} \times 40$$

$$\Delta L \text{ (in mm)} = H \text{ (in m)} \times 27$$

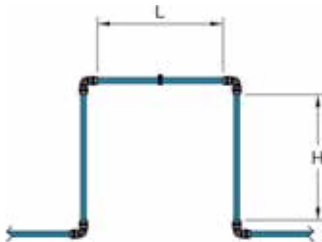

Maximum compensation:
Ø1/2" mm to Ø2-1/2" mm:

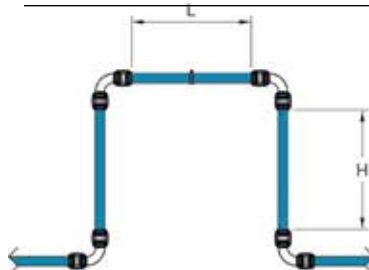

Maximum compensation:
Ø3" mm to Ø6" mm

Z Dimensions

	Z	Z1	Z2
4002 40 00	-	4 13/16	2 1/4
4002 63 00	-	3 5/16	3 7/8
4089 17 00	-	1 1/8	1 11/16
4099 17 00	-	1 1/8	1 11/16
4099 25 00	-	1 9/16	2 3/16
4230 00 40	3 3/8	-	-
6612 25 00	1 1/8	-	-
6612 40 00	1 3/4	-	-
6612 63 00	2 3/8	-	-
6602 17 00	1 1/4	-	-
6602 25 00	1 9/16	-	-
6602 40 00	2 7/16	-	-
6602 50 00	2 1/4	-	-
6602 63 00	2 3/8	-	-
6604 17 00	-	1 5/16	1 1/4
6604 25 00	-	1 7/8	1 9/16
6604 40 00	-	2 1/4	2 1/4
6604 50 00	-	2 3/16	2 3/16
6604 63 00	-	2 7/16	2 7/16
6604 63 40	-	2 7/16	4 9/16
6606 17 00	1 5/16	-	-
6606 25 00	1 7/8	-	-
6606 40 00	2 1/4	-	-
6606 50 00	1	-	-
6606 63 00	1	-	-
6651 25 12 04	4 1/4	-	-
6651 40 12 04	5 15/16	-	-
6662 25 00	1 7/8	-	-
6662 25 17	3 1/4	-	-
6662 40 17	3 1/2	-	-
6662 40 25	3 1/4	-	-
6662 50 25	2 5/16	-	-
6662 63 25	3	-	-
6666 17 25	2	-	-

	Z	Z1	Z2
6666 25 40	2 13/16	-	-
6676 25 00	1 7/8	-	-
6676 40 00	2 1/4	-	-
6676 50 00	1	-	-
6676 63 00	1	-	-
RA02 L8 00	7 1/4	-	-
RA04 L8 00	-	7 1/16	7 5/16
RA04 L8 L3	-	6 1/2	7 5/16
RA04 L8 L1	-	6 1/2	7 5/16
RA04 L8 63	-	6 1/2	8 11/16
RA66 L8 L1	210	-	-
RA66 L8 L3	210	-	-
RA69 25 17	1 7/8	-	-
RA69 40 25	2 1/4	-	-
RA69 50 25	2 5/8	-	-
RX02 L1 00	7 7/16	-	-
RX02 L3 00	8 11/16	-	-
RX04 L1 00	-	5 11/16	5 11/16
RX04 L3 00	-	6 1/8	5 5/16
RX04 L3 L1	-	6 1/8	5 5/16
RX24 L1 40	-	5 11/16	4 1/8
RX24 L1 63	-	5 11/16	6 7/16
RX24 L3 40	-	6 1/8	4 5/8
RX24 L3 63	-	6 1/8	6 15/16
RX64 L1 63	13 7/8	-	-
RX64 L3 63	14 5/8	-	-
RX66 L3 L1	7 5/8	-	-
VR02 L1 00	4 9/16	-	-
VR02 L3 00	4 7/8	-	-
VR02 L8 00	5 1/16	-	-

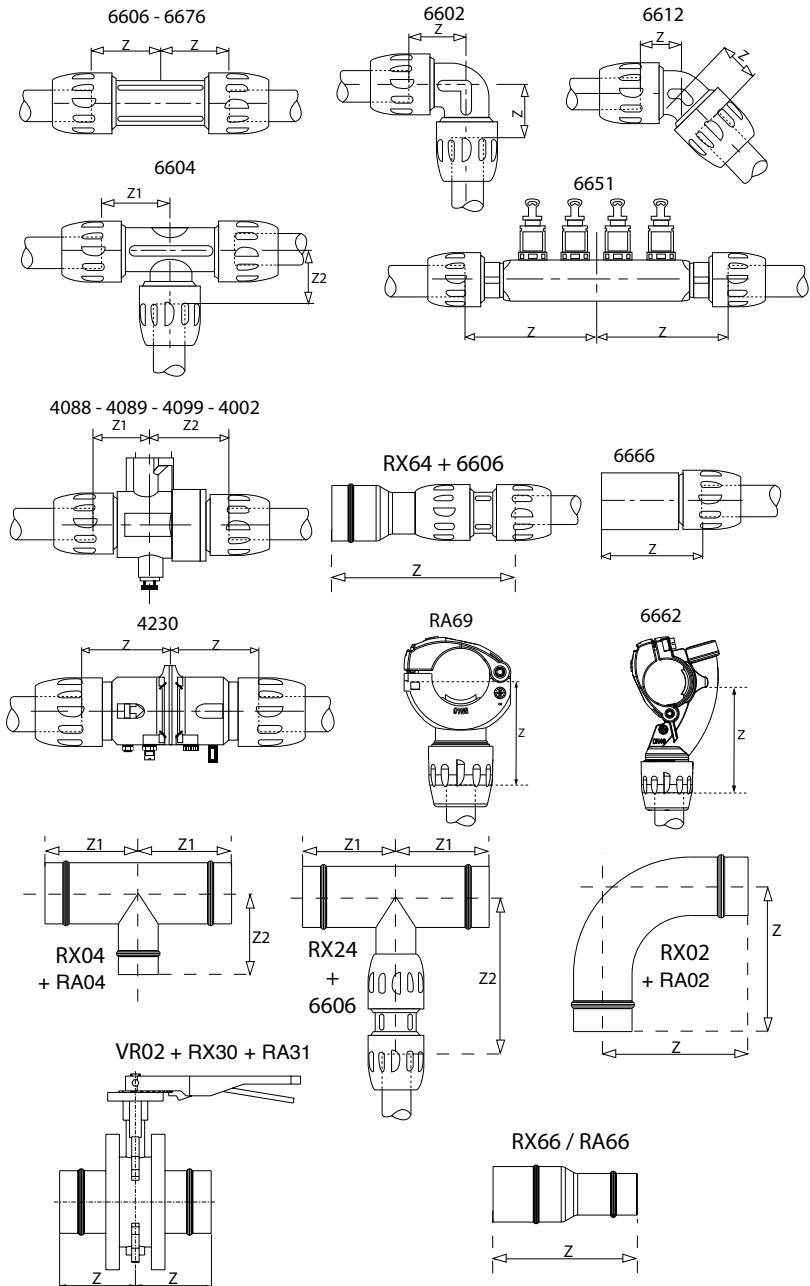

Transair 316L Drops Installation Process



Assembly:

Simply push the pipe into the fitting.



Disassembly:

1. Manually unscrew the nut and slide the nut along the pipe.



Disassembly:

2. Put the red dismounting ring on the pipe and re-screw the nut on the fitting.



Disassembly:

3. Pull the pipe from the fitting.



Disassembly:

4. Manually unscrew the nut and remove the red dismounting ring.



Disassembly:

5. Re-screw the nut on the fitting without the red ring; it is ready for assembly.

These components can quickly and easily connect to existing Transair aluminum or stainless steel systems with threaded drop brackets.

Transair Stainless Steel Installation Guidelines

Specifications:

Max Working Pressure	145psi from -4° to +140° F (10 bar from -20° to +60° C)
Vacuum:	99% (29.6" Hg)
Working Temperature	-4° to +140° F (-20° to +60° C)

* Please consult us for higher temperature requirements

General

Prior to the Installation of a Transair® system, the installer should ensure the installation area complies with all safety and hazard regulations. Transair® can be installed in the compressor room, as well as downstream for the distribution piping system. Transair® flexible hoses can be installed to dampen sources of vibration.

When modifying or repairing a Transair® system, ensure the section of pipe where work will take place has been properly vented prior to beginning modifications.

Only genuine Transair® parts should be used for installation. The use of non-Transair® parts with Transair® parts will result in the 10 year warranty being voided. Refer to the technical data in Transair® Catalog 3515 for proper sizing and selection of components.

Pressurizing the system

Once the Transair® system installation has been completed, and prior to pressurizing the system, the installer should complete all tests, inspections, and compliance checks according to customer requirements, engineering best practices, and building code regulations.

Transair® pipe and hoses

Transair® piping needs to be protected from mechanical impact. All Transair® piping systems should be installed out of reach of fork-lifts and above overhead material handling cranes.

Only use genuine Transair® connectors to connect sections of pipe. Transair® pipe should never be welded, soldered, or glued. Transair® Flexible hoses can be installed to route around obstacles following proper installation guidelines.

Note: In certain situations, Transair® piping can be bent - contact the factory for further information.



WARNING These products can expose you to chemicals including Lead and Lead Compounds, which is known to the state of California to cause cancer and birth defects or other reproductive harm. For more information go to www.P65Warnings.ca.gov.



Expansion / contraction

Prior to installation, ensure the expansion and contraction of the piping system has been properly calculated. The elongation and retraction of each Transair® line should be calculated according to the information found in this installation guide.

Component assembly

For proper installation of a Transair® System, follow the steps outlined in this document.

When installing Transair® piping, avoid the following

- Installing within a solid mass (concrete, foam, etc)
- Hanging external equipment from Transair® pipe
- Using Transair® for grounding, or conduit for electrical wires.
- Exposing Transair® components to incompatible chemicals.
(Contact the factory for further information)

Compressed Air System Design Best Practices

- When installing a Transair system, ensure you follow all local building code regulations
- To reduce the occurrence of pressure drop, eliminate excessive use of elbows and keep the use bypasses and in-line pipe reductions to a minimum.
- Maintain consistent, high quality compressed air through the use of filtration elements in the compressor room and point of use.
- Size the diameter of the pipe according to the required flow rate and the acceptable pressure drop at the point of use.
- Install air drops as close as possible to the point of use.

 **WARNING** These products can expose you to chemicals including Lead and Lead Compounds, which is known to the state of California to cause cancer and birth defects or other reproductive harm. For more information go to www.P65Warnings.ca.gov.



3/4" (22mm)
1" (28mm)

Deburred and chamfered pipe



1-1/2" (42mm)
2" (60mm)

Pipe lugged at each end,
deburred and chamfered



3" (76mm)
4" (101mm)

Pipe lugged at each end,
deburred and chamfered

 **WARNING** These products can expose you to chemicals including Lead and Lead Compounds, which is known to the state of California to cause cancer and birth defects or other reproductive harm. For more information go to www.P65Warnings.ca.gov.

General Information

Transair® stainless steel pipe is supplied “ready for use”. No particular preparation (cutting, deburring, chamfering, etc.) is required. Thanks to the rigidity of Transair® stainless steel pipe, temperature-related expansion / contraction phenomena are reduced to a minimum. The Transair® network retains its straightness, and hence its performance, over time (reduction of pressure drop caused by surface friction). Transair® stainless steel pipe is calibrated and fits perfectly onto all Transair® components. Each connection is automatically secured and sealing is, thus, optimized. The use of Transair® stainless steel pipe minimises corrosion.

STANDARDS	3/4" TO 1" (22MM TO 28MM)	1-1/2" TO 2" (42MM TO 60MM)	3" TO 4" (76MM TO 101MM)
MANUFACTURING STANDARDS	EN 10217-7	EN 10217-7	EN 10217-7
GRADE	EN 10088-2, 1.4404 / AISI 316 L	1.4301 / AISI 304	1.4301 / AISI 304
WELDING STANDARDS	DIN 17 457, EN 10217-7	DIN 17 457, EN 10217-7	DIN 17 457, EN 10217-7
TOLERANCES	DVGW - W541	EN 1127 D4 / T3	EN 1127 D4 / T3

Volume and Mass

OUTSIDE DIAMETER		INSIDE DIAMETER		VOLUME		PIPE MASS		SYSTEM MASS (FULL OF WATER)	
(IN)	(MM)	(IN)	(MM)	GALLON	LITER	(LB)	(KG)	(LB)	(KG)
3/4	22	0.77	19.6	0.07	0.3	1.38	0.63	2.04	0.93
1	28	1	25.6	0.13	0.51	1.78	0.81	2.91	1.32
1-1/2	42	1.53	39.1	0.31	1.20	3.56	1.62	6.21	2.82
2	60	2.24	57.1	0.67	2.56	5.13	2.33	10.78	4.90
3	76	2.87	72.9	1.10	4.17	6.52	2.96	15.72	7.13
4	101	3.84	97.6	1.97	7.48	10.89	4.94	27.39	12.43

Values are for 3' (1m) of pipe

 **WARNING** These products can expose you to chemicals including Lead and Lead Compounds, which is known to the state of California to cause cancer and birth defects or other reproductive harm. For more information go to www.P65Warnings.ca.gov.



Stainless Steel Pipe

3/4" to 1"

Tools



Pipe-Cutter
6698 03 01



Chamfering Tool
6698 04 01



Deburring Tool
6698 04 02



Marker Pen

3/4" to 1" Pipe Cutting Process

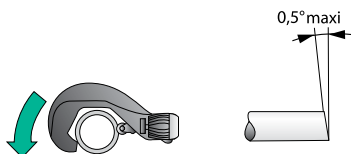

1. Cutting the pipe:

- Position the blade of the cutter on the pipe, the rotate the pipe cutter around the pipe, gently tightening the blade wheel after each pass.

The cutter cannot be more than 0.5 degrees off of square while cutting.

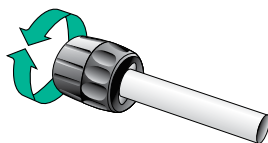

2. Carefully chamfer the outer edges



3. Deburr the interior edge of the pipe

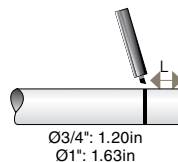

4. Using a tape measure, mark the insertion depth of the connector.

⚠ WARNING These products can expose you to chemicals including Lead and Lead Compounds, which is known to the state of California to cause cancer and birth defects or other reproductive harm. For more information go to www.P65Warnings.ca.gov.

1-1/2" to 4"

Tools



Pipe-Cutter



File



Deburring Tool



Portable Tool Kit Ref.
EW01 00 02



Pipe Forming Jaw Set Ref.
EW02 M4 00 (Ø 42) EW02 L1 00 (Ø 76)
EW02 M6 00 (Ø 60) EW02 L3 00 (Ø 101)

1-1/2" to 4" Pipe Cutting Process

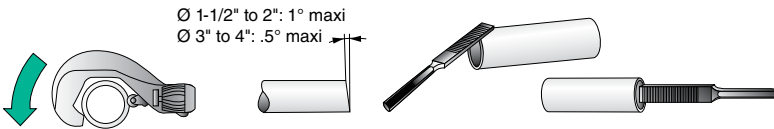

1. Cutting the pipe:

- Position the blade of the cutter on the pipe, then rotate the pipe cutter around the pipe, gently tightening the blade wheel after each pass. The cutter cannot be more than 0.5 or 1 degrees off of square while cutting. (depending on diameter)

2. Carefully chamfer and deburr the edge of the pipe with a file.

WARNING These products can expose you to chemicals including Lead and Lead Compounds, which is known to the state of California to cause cancer and birth defects or other reproductive harm. For more information go to www.P65Warnings.ca.gov.

Preparing the portable lugging tool



Open the retaining pin at the front of the machine by pressing the jaw to release button*.



Place the jaw in the housing.



Lock into position by closing the retaining pin.

Creating the Lugs



Manually open the jaw and insert the stainless steel pipe until the pipe meets the stop in the jaw.



Release the jaw then press the trigger and lug the pipe until a "snap" is heard.



Re-open the jaw to remove the pipe. Position the end of the jaw next to the lug mark: this will help to prevent overlapping the lugs.



Repeat the operation until the required minimum of lugs for each diameter have been achieved.

	1-1/2"	2"	3"	4"
MINIMUM NUMBER OF LUGS	4	4	6	7

WARNING These products can expose you to chemicals including Lead and Lead Compounds, which is known to the state of California to cause cancer and birth defects or other reproductive harm. For more information go to www.P65Warnings.ca.gov.

Pipe-to-Pipe Connectors for Stainless Steel

3/4" to 1" Instant Connection by Means of a Gripping Ring

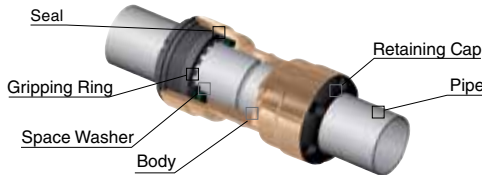

In sizes 3/4" (22mm), and 1" (28mm), Transair stainless steel pipe uses push to connect technology. Simply push the pipe into the connector until it meets the depth mark on the pipe. The gripping ring will then engage and prevent the pipe from sliding out of the connector.

1-1/2" to 2" Double-Clamp Quick-Fit Connection



In sizes 3" (76mm), and 4" (101mm), Transair stainless steel pipe uses clamshell technology. Place the cartridge on the pipe so it meets the lug. Then position the connector so the cartridge is in the middle. Lastly, close the connector and tighten with the provided bolts.

3" to 4" Clamp Quick-Fit Connection

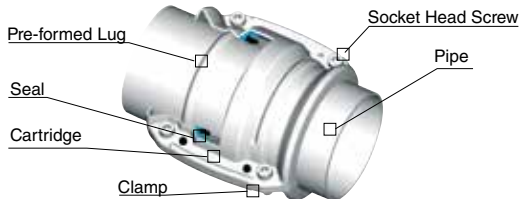

Pipe-to-pipe and stud connectors in Ø76 and Ø101 can be quickly connected to Transair® stainless steel pipe. Position the pipes to be connected within the Transair® cartridge and close/tighten the Transair® clamp.

WARNING These products can expose you to chemicals including Lead and Lead Compounds, which is known to the state of California to cause cancer and birth defects or other reproductive harm. For more information go to www.P65Warnings.ca.gov.

Connector Connection and Dismantling Process

3/4" to 1"

Tools



Dismounting Tool EW11 00 01

Connection

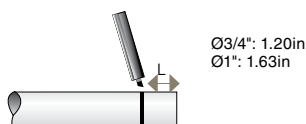

1. Using a tape measure, mark the insertion depth on the pipe.



2. Insert the pipe into the connector until the line meets the edge of the connector

WARNING These products can expose you to chemicals including Lead and Lead Compounds, which is known to the state of California to cause cancer and birth defects or other reproductive harm. For more information go to www.P65Warnings.ca.gov.

Disconnection

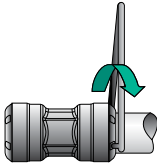

1. Place the prongs of dismounting tool in pegs on opposite ends of the pipe. Turn the tool counter-clockwise to release the end cap.

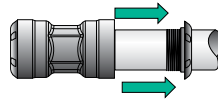

2. Un-thread the end cap and pull away from the body

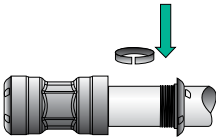

3. Place the appropriate dismounting ring (depending on diameter size of the connector) around the pipe in-between the body and cap.

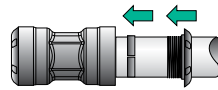

4. Insert the dismounting ring into the connector body and return the end cap.

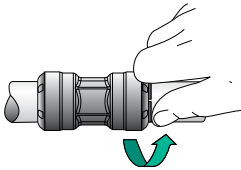

5. Hand tighten the end cap

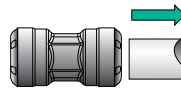

6. Remove the connector from the pipe

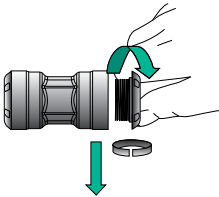

7. Un-thread the end cap and remove the dismounting ring

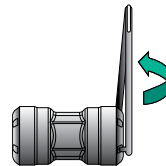

8. Return the end cap and use the dismounting tool to thread the cap back onto the body.



WARNING These products can expose you to chemicals including Lead and Lead Compounds, which is known to the state of California to cause cancer and birth defects or other reproductive harm. For more information go to www.P65Warnings.ca.gov.

1-1/2" to 2"

Connection/Disconnection

-
1. Unscrew one of the connector nuts and slide over the pipe
 2. Position the clamp ring over the lugs
 3. Slide the nut that is on the pipe towards the end until it stops against the clamp ring.
 4. Thread the connector body into the connector nut and hand tighten
 5. Complete the first half of the assembly by tightening the connector one-half (1/2) turn with the Transair spanner wrenches
 6. Repeat steps 1 through 5 to secure the second half of the assembly
 7. To disconnect the connector, perform the same steps, but in reverse order.

Lateral Dismounting

-
1. Remove one of the connector nuts and remove the clamp ring
 2. Remove the connector body
 3. Repeat steps 1 and 2 on the other side and remove the pipe

WARNING These products can expose you to chemicals including Lead and Lead Compounds, which is known to the state of California to cause cancer and birth defects or other reproductive harm. For more information go to www.P65Warnings.ca.gov.

Replacing a Union Connector with a Tee Connector

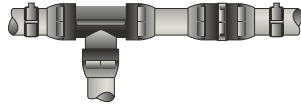

1. On one end of the pipe, make a cut equal to the L dimension for the given dimension and lug the pipe following the procedures on page E
2. Connect the tee fitting following the clamp ring installation steps on page E

Ø	L (IN)
42	4.13
60	4.84

The body of the 1-1/2" and 2" connector tees are longer than the union connectors. An additional cut and lugging are required to swap a union for a tee.

Add 1 Tee

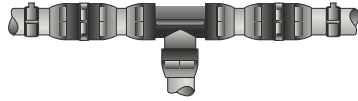
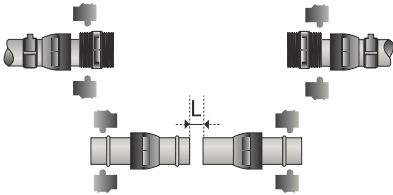

1. First remove the section of pipe where the tee is to be installed. All work should be performed on the ground. Then make a cut equal to the L dimension for the given dimension and lug the pipe following the procedures on page E
2. Connect the tee fitting and unions following the clamp ring installation steps on page E

Ø	L (IN)
42	2.36
60	4.33

WARNING These products can expose you to chemicals including Lead and Lead Compounds, which is known to the state of California to cause cancer and birth defects or other reproductive harm. For more information go to www.P65Warnings.ca.gov.

3" to 4"

Connection/Disconnection

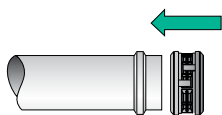

1. Slide the cartridge over the end of the first pipe until it meets the lug

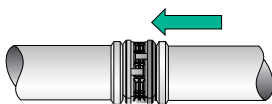

2. Bring the second pipe to the cartridge and slide the pipe until the cartridge meets the lug

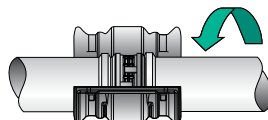

3. Position the clamshell connector over the cartridge / pipe assembly. The cartridge should fall in the middle of the connector

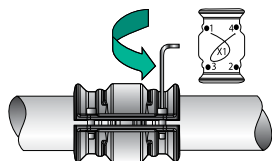

4. Hand-tighten the bolts in a cross pattern with an allen wrench. see chart below for sizes)

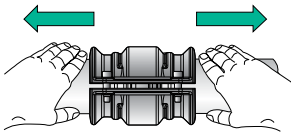

5. Pull the pipes back towards the outside of the clamshell

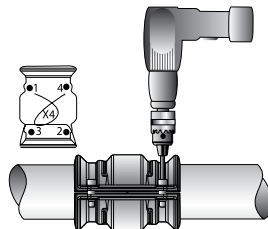

6. Using a drill, fully tighten the clamshell bolts in a cross pattern

Torque Specs: 7.38 lb•ft to 29.5 lb•ft

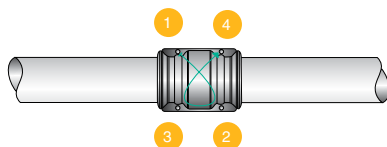

For effective sealing, follow the above diagram for securing the bolts in a cross pattern.

Allen Wrench Sizes

TRANSAIR DIAMETER	ALLEN WRENCH SIZE
3" (76MM)	6MM
4" (101MM)	6MM

Disconnection

To disconnect the connector, perform the same steps, but in reverse order.

WARNING These products can expose you to chemicals including Lead and Lead Compounds, which is known to the state of California to cause cancer and birth defects or other reproductive harm. For more information go to www.P65Warnings.ca.gov.

Practical Examples

Various Ø3" and Ø4" configurations

Installing a 90° elbow



Installing a tee

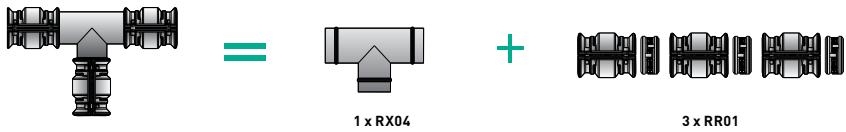

Installing an end cap

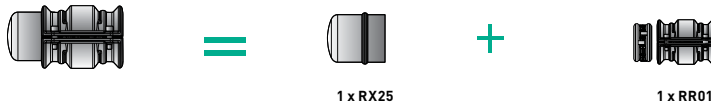

Installing a flange and connector

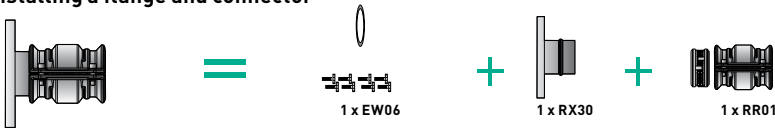

Reducing from 4" to 3"



Installing a butterfly valve

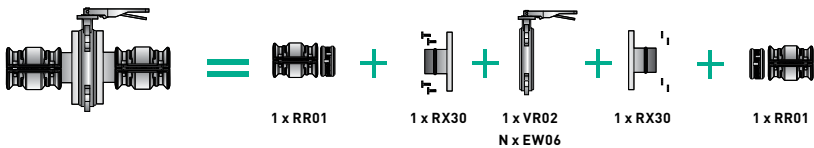

⚠ WARNING These products can expose you to chemicals including Lead and Lead Compounds, which is known to the state of California to cause cancer and birth defects or other reproductive harm. For more information go to www.P65Warnings.ca.gov.

Drop Brackets

Installing a Drop Bracket

1-1/2" to 4" Pipe

Tools Required



Drilling Tool For Transair®
Stainless Steel Pipe
EW09 00 22
EW09 00 30



Deburring Tool For Transair®
Stainless Steel Pipe
6698 04 02

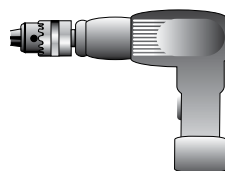

Drill

Drop Bracket Installation Process

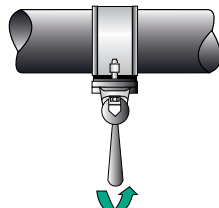
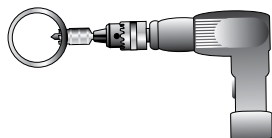

1. Mark the location for the drop bracket. Then using the appropriate drilling tool, drill the hole for the drop bracket.
2. Remove any chips and carefully deburr the hole ensuring no rough edges are left behind.
3. Position the plug of the bracket in the hole and tighten the bolts using a crescent wrench.

- Ø42 - Ø60: drilling tool EW09 00 22
- Ø76 - Ø101: drilling tool EW09 00 30

WARNING These products can expose you to chemicals including Lead and Lead Compounds, which is known to the state of California to cause cancer and birth defects or other reproductive harm. For more information go to www.P65Warnings.ca.gov.

Pipe Hangers

3/4" to 4"

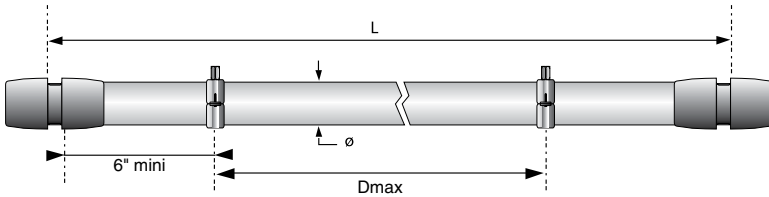

L = 20ft

\emptyset	DMAX (FT)
22	9.8
28	9.8
42	13.12
60	13.12
76	16.40
101	16.40

It is recommended that all hanging / support calculations be done prior to installing and determining fixture installation configuration. CHECK WITH ENGINEERING

To ensure a stable piping system, Parker Transair suggests the use of at least 2 hangers per pipe. Transair stainless steel pipe should only be mounted using genuine Transair pipe hangers. Additional hangers may be necessary depending on the weight of the media being conveyed. Consult with engineering to determine if additional hangers are necessary.

WARNING These products can expose you to chemicals including Lead and Lead Compounds, which is known to the state of California to cause cancer and birth defects or other reproductive harm. For more information go to www.P65Warnings.ca.gov.



Bending Transair® Stainless Steel Pipe

All Diameters

Due to the quality alloys used, all Transair stainless steel pipes can be bent according to the following specifications.

OD (IN)	R MIN. (IN)	L MIN. (IN)
3/4	1.73	4.92
1	2.20	4.92
1-1/2	3.30	4.92
2	3.66	4.92
3	4.48	4.92
4	5.98	4.92

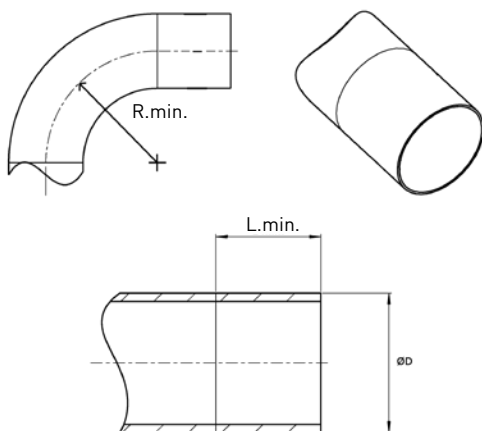

WARNING These products can expose you to chemicals including Lead and Lead Compounds, which is known to the state of California to cause cancer and birth defects or other reproductive harm. For more information go to www.P65Warnings.ca.gov.

Z Dimensions

RR02 N7 - RR02 N9

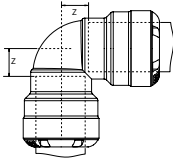

RP02 M4 - RP02 M6

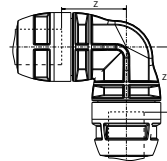

RP02/RR02	Z (IN)	Z (MM)
Ø 3/4	.51	13
Ø 1	.59	15

RP02	Z (IN)	Z (MM)
Ø 1-1/2	2.17	55
Ø 2	2.52	64

RR06 N7 - RR06 N9

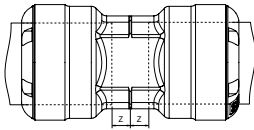

RP06 M4 - RP06 M6

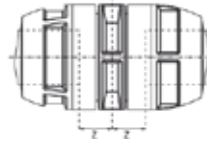

RR06	Z (IN)	Z (MM)
Ø 3/4	.05	1.2
Ø 1	.05	1.2
Ø 3/4 - > Ø 1	.06	1.6

RP06	Z (IN)	Z (MM)
Ø 1-1/2	.10	2.6
Ø 2	.10	2.6

WARNING These products can expose you to chemicals including Lead and Lead Compounds, which is known to the state of California to cause cancer and birth defects or other reproductive harm. For more information go to www.P65Warnings.ca.gov.



RP04

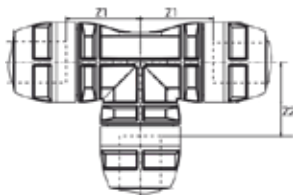

RR04	Z1 (IN)	Z1 (MM)	Z1 (IN)	Z2 (MM)
Ø 1-1/2	2.17	55	2.17	55
Ø 2	2.52	64	2.52	64

RR04 N9 N7

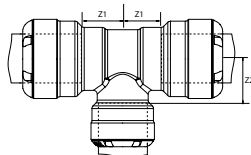

RR04 N7 - RR04 N9

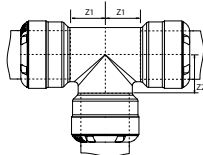

RR04	Z1 (IN)	Z1 (MM)	Z1 (IN)	Z2 (MM)
Ø 22	.46	11.7	.43	11
Ø 28	.59	15	.59	15
Ø 28 -> Ø 22	.63	12	.63	16

RX02 L1 00 - RX02 L3 00

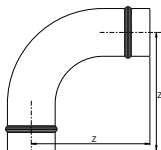

RX02	Z (IN)	Z (MM)
Ø 3	7.44	189
Ø 4	8.94	227

RR05 N7 04 - RR05 N7 06
RR05 N9 08

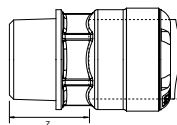

RR05	Z (IN)	Z (MM)
RR05 N7 04	.83	21
RR05 N7 06	.87	22
RR05 N9 08	.94	24



WARNING These products can expose you to chemicals including Lead and Lead Compounds, which is known to the state of California to cause cancer and birth defects or other reproductive harm. For more information go to www.P65Warnings.ca.gov.

RX04 L1 00 - RX04 L3 00

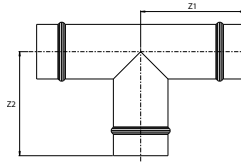

RX04	Z1 (IN)	Z1 (MM)	Z1 (IN)	Z2 (MM)
Ø 3	5.75	146	5.75	146
Ø 3 - > Ø 1-1/2	5.75	146	7.17	182
Ø 3 - > Ø 2	5.75	146	7.20	183
Ø 4	6.14	156	5.35	136
Ø 4 - > Ø 1-1/2	6.14	156	7.72	196
Ø 4 - > Ø 2	6.14	156	7.72	196
Ø 4 - > Ø 3	6.14	156	5.35	136

RR23 N7 06

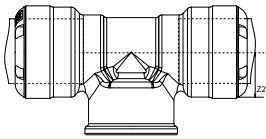

RX23 L1 04 - RX23 L3 04

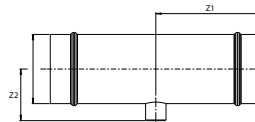

RR23/RX23	Z1 (MM)	Z1 (MM)	Z1 (MM)	Z2 (MM)
Ø 3/4	.47	12	.55	14
Ø 3	5.75	146	2.48	63
Ø 4	6.14	156	2.99	76



WARNING These products can expose you to chemicals including Lead and Lead Compounds, which is known to the state of California to cause cancer and birth defects or other reproductive harm. For more information go to www.P65Warnings.ca.gov.



Parker Safety Guide for Selecting and Using Hose, Tubing, Fittings, Connectors, Conductors, Valves and Related Accessories

Parker Publication No. 4400-B.1

WARNING: Failure or improper selection or improper use of hose, tubing, fittings, assemblies, valves, connectors, conductors or related accessories (“Products”) can cause death, personal injury and property damage. Possible consequences of failure or improper selection or improper use of these Products include but are not limited to:

- Fittings thrown off at high speed.
- High velocity fluid discharge.
- Explosion or burning of the conveyed fluid.
- Electrocutation from high voltage electric powerlines.
- Contact with suddenly moving or falling objects that are controlled by the conveyed fluid.
- Injections by high-pressure fluid discharge.
- Dangerously whipping Hose.
- Tube or pipe burst.
- Weld joint fracture.
- Contact with conveyed fluids that may be hot, cold, toxic or otherwise injurious.
- Sparking or explosion caused by static electricity buildup or other sources of electricity.
- Sparking or explosion while spraying paint or flammable liquids.
- Injuries resulting from inhalation, ingestion or exposure to fluids.

Before selecting or using any of these Products, it is important that you read and follow the instructions below. No product from any division in Fluid Connector Group is approved for in-flight aerospace applications. For hoses and fittings used in in-flight aerospace applications, please contact Parker Aerospace Group

GENERAL INSTRUCTIONS

- 1.0 **Scope:** This safety guide provides instructions for selecting and using (including assembling, installing, and maintaining) these Products. For convenience, all rubber and/or thermoplastic products commonly called “hose” or “tubing” are called “Hose” in this safety guide. Metallic tube or pipe are called “tube”. All assemblies made with Hose are called “Hose Assemblies”. All assemblies made with Tube are called “Tube Assemblies”. All products commonly called “fittings”, “couplings” or “adapters” are called “Fittings”. Valves are fluid system components that control the passage of fluid. Related accessories are ancillary devices that enhance or monitor performance including crimping, flaring, flanging, presetting, bending, cutting, deburring, swaging machines, sensors, tags, lockout handles, spring guards and associated tooling. This safety guide is a supplement to and is to be used with the specific Parker publications for the specific Hose, Fittings and Related Accessories that are being considered for use. Parker publications are available at www.parker.com. SAE J1273 (www.sae.org) and ISO 17165-2 (www.ansi.org) also provide recommended practices for hydraulic Hose Assemblies, and should be followed.
- 1.1 **Fail-Safe:** Hose, Hose Assemblies, Tube, Tube Assemblies and Fittings can and do fail without warning for many reasons. Design all systems and equipment in a fail-safe mode, so that failure of the Hose, Hose Assembly, Tube, Tube Assembly or Fitting will not endanger persons or property.
- 1.2 **Distribution:** Provide a copy of this safety guide to each person responsible for selecting or using Hose, Tube and Fitting products. Do not select or use Parker Hose, Tube or Fittings without thoroughly reading and understanding this safety guide as well as the specific Parker publications for the Products.
- 1.3 **User Responsibility:** Due to the wide variety of operating conditions and applications for Hose, Tube and Fittings. Parker does not represent or warrant that any particular Hose, Tube or Fitting is suitable for any specific end use system. This safety guide does not analyze all technical parameters that must be considered in selecting a product. The user, through its own analysis and testing, is solely responsible for:
 - Making the final selection of the Products.
 - Assuring that the user’s requirements are met and that the application presents no health or safety hazards.
 - Following the safety guide for Related Accessories and being trained to operate Related Accessories.
 - Providing all appropriate health and safety warnings on the equipment on which the Products are used.
 - Assuring compliance with all applicable government and industry standards.
- 1.4 **Additional Questions:** Call the appropriate Parker technical service department if you have any questions or require any additional information. See the Parker publication for the Products being considered or used, or call 1-800-CPARKER, or go to www.parker.com, for telephone numbers of the appropriate technical service department.



2.0 HOSE, TUBE AND FITTINGS SELECTION INSTRUCTIONS

- 2.1 Electrical Conductivity:** Certain applications require that the Hose be nonconductive to prevent electrical current flow. Other applications require the Hose and the Fittings and the Hose/Fitting interface to be sufficiently conductive to drain off static electricity. Extreme care must be exercised when selecting Hose, Tube and Fittings for these or any other applications in which electrical conductivity or nonconductivity is a factor.

The electrical conductivity or nonconductivity of Hose, Tube and Fittings is dependent upon many factors and may be susceptible to change. These factors include but are not limited to the various materials used to make the Hose and the Fittings, Fitting finish (some Fitting finishes are electrically conductive while others are nonconductive), manufacturing methods (including moisture control), how the Fittings contact the Hose, age and amount of deterioration or damage or other changes, moisture content of the Hose at any particular time, and other factors.

The following are considerations for electrically nonconductive and conductive Hose. For other applications consult the individual catalog pages and the appropriate industry or regulatory standards for proper selection.

- 2.1.1 Electrically Nonconductive Hose:** Certain applications require that the Hose be nonconductive to prevent electrical current flow or to maintain electrical isolation. For applications that require Hose to be electrically nonconductive, including but not limited to applications near high voltage electric lines, only special nonconductive Hose can be used. The manufacturer of the equipment in which the nonconductive Hose is to be used must be consulted to be certain that the Hose, Tube and Fittings that are selected are proper for the application. Do not use any Parker Hose or Fittings for any such application requiring nonconductive Hose, including but not limited to applications near high voltage electric lines or dense magnetic fields, unless (i) the application is expressly approved in the Parker technical publication for the product, (ii) the Hose is marked "nonconductive", and (iii) the manufacturer of the equipment on which the Hose is to be used specifically approves the particular Parker Hose, Tube and Fittings for such use.
- 2.1.2 Electrically Conductive Hose:** Parker manufactures special Hose for certain applications that require electrically conductive Hose. Parker manufactures special Hose for conveying paint in airless paint spraying applications. This Hose is labeled "Electrically Conductive Airless Paint Spray Hose" on its layline and packaging. This Hose must be properly connected to the appropriate Parker Fittings and properly grounded in order to dissipate dangerous static charge buildup, which occurs in all airless paint spraying applications. Do not use any other Hose for airless paint spraying, even if electrically conductive. Use of any other Hose or failure to properly connect the Hose can cause a fire or an explosion resulting in death, personal injury, and property damage. All hoses that convey fuels must be grounded. Parker manufactures a special Hose for certain compressed natural gas ("CNG") applications where static electricity buildup may occur. Parker CNG Hose assemblies comply with the requirements of ANSI/IAS NGV 4.2; CSA 12.52, "Hoses for Natural Gas Vehicles and Dispensing Systems" (www.ansi.org). This Hose is labeled "Electrically Conductive for CNG Use" on its layline and packaging. This Hose must be properly connected to the appropriate Parker Fittings and properly grounded in order to dissipate dangerous static charge buildup, which occurs in, for example, high velocity CNG dispensing or transfer. Do not use any other Hose for CNG applications where static charge buildup may occur, even if electrically conductive. Use of other Hoses in CNG applications or failure to properly connect or ground this Hose can cause a fire or an explosion resulting in death, personal injury, and property damage. Care must also be taken to protect against CNG permeation through the Hose wall. See section 2.6, Permeation, for more information. Parker CNG Hose is intended for dispenser and vehicle use within the specified temperature range. Parker CNG Hose should not be used in confined spaces or unventilated areas or areas exceeding the specified temperature range. Final assemblies must be tested for leaks. CNG Hose Assemblies should be tested on a monthly basis for conductivity per ANSI/IAS NGV 4.2; CSA 12.52. Parker manufactures special Hose for aerospace in-flight applications. Aerospace in-flight applications employing Hose to transmit fuel, lubricating fluids and hydraulic fluids require a special Hose with a conductive inner tube. This Hose for in-flight applications is available only from Parker's Stratoflex Products Division. Do not use any other Parker Hose for in-flight applications, even if electrically conductive. Use of other Hoses for in-flight applications or failure to properly connect or ground this Hose can cause a fire or an explosion resulting in death, personal injury and property damage. These Hose assemblies for in-flight applications must meet all applicable aerospace industry, aircraft engine and aircraft requirements.
- 2.2 Pressure:** Hose, Tube and Fitting selection must be made so that the published maximum working pressure of the Hose, Tube and Fittings are equal to or greater than the maximum system pressure. The maximum working pressure of a Hose, or Tube Assembly is the lower of the respective

published maximum working pressures of the Hose, Tube and the Fittings used. Surge pressures or peak transient pressures in the system must be below the published maximum working pressure for the Hose, Tube and Fitting. Surge pressures and peak pressures can usually only be determined by sensitive electrical instrumentation that measures and indicates pressures at millisecond intervals. Mechanical pressure gauges indicate only average pressures and cannot be used to determine surge pressures or peak transient pressures. Published burst pressure ratings for Hose is for manufacturing test purposes only and is no indication that the Product can be used in applications at the burst pressure or otherwise above the published maximum recommended working pressure.

- 2.3 Suction: Hoses used for suction applications must be selected to insure that the Hose will withstand the vacuum and pressure of the system. Improperly selected Hose may collapse in suction application.
- 2.4 Temperature: Be certain that fluid and ambient temperatures, both steady and transient, do not exceed the limitations of the Hose, Tube, Fitting and Seals. Temperatures below and above the recommended limit can degrade Hose, Tube, Fittings and Seals to a point where a failure may occur and release fluid. Tube and Fittings performances are normally degraded at elevated temperature. Material compatibility can also change at temperatures outside of the rated range. Properly insulate and protect the Hose Assembly when routing near hot objects (e.g. manifolds). Do not use any Hose in any application where failure of the Hose could result in the conveyed fluids (or vapors or mist from the conveyed fluids) contacting any open flame, molten metal, or other potential fire ignition source that could cause burning or explosion of the conveyed fluids or vapors.
- 2.5 Fluid Compatibility: Hose, and Tube Assembly selection must assure compatibility of the Hose tube, cover, reinforcement, Tube, Plating and Seals with the fluid media used. See the fluid compatibility chart in the Parker publication for the product being considered or used. This information is offered only as a guide. Actual service life can only be determined by the end user by testing under all extreme conditions and other analysis. Hose, and Tube that is chemically compatible with a particular fluid must be assembled using Fittings and adapters containing likewise compatible seals. Flange or flare processes can change Tube material properties that may not be compatible with certain requirements such as NACE
- 2.6 Permeation: Permeation (that is, seepage through the Hose or Seal) will occur from inside the Hose or Fitting to outside when Hose or Fitting is used with gases, liquid and gas fuels, and refrigerants (including but not limited to such materials as helium, diesel fuel, gasoline, natural gas, or LPG). This permeation may result in high concentrations of vapors which are potentially flammable, explosive, or toxic, and in loss of fluid. Dangerous explosions, fires, and other hazards can result when using the wrong Hose for such applications. The system designer must take into account the fact that this permeation will take place and must not use Hose or Fitting if this permeation could be hazardous. The system designer must take into account all legal, government, insurance, or any other special regulations which govern the use of fuels and refrigerants. Never use a Hose or Fitting even though the fluid compatibility is acceptable without considering the potential hazardous effects that can result from permeation through the Hose or Tube Assembly. Permeation of moisture from outside the Hose or Fitting to inside the Hose or Fitting will also occur in Hose or Tube assemblies, regardless of internal pressure. If this moisture permeation would have detrimental effects (particularly, but not limited to refrigeration and air conditioning systems), incorporation of sufficient drying capacity in the system or other appropriate system safeguards should be selected and used. The sudden pressure release of highly pressurized gas could also result in Explosive Decompression failure of permeated Seals and Hoses.
- 2.7 Size: Transmission of power by means of pressurized fluid varies with pressure and rate of flow. The size of the components must be adequate to keep pressure losses to a minimum and avoid damage due to heat generation or excessive fluid velocity.
- 2.8 Routing: Attention must be given to optimum routing to minimize inherent problems (kinking or flow restriction due to Hose collapse, twisting of the Hose, proximity to hot objects or heat sources). For additional routing recommendations see SAE J1273 and ISO 17165-2. Hose Assemblies have a finite life and should be installed in a manner that allows for ease of inspection and future replacement. Hose because of its relative short life, should not be used in residential and commercial buildings inside of inaccessible walls or floors, unless specifically allowed in the product literature. Always review all product literature for proper installation and routing instructions.
- 2.9 Environment: Care must be taken to insure that the Hose, Tube and Fittings are either compatible with or protected from the environment (that is, surrounding conditions) to which they are exposed. Environmental conditions including but not limited to ultraviolet radiation, sunlight, heat, ozone, moisture, water, salt water, chemicals and air pollutants can cause degradation and premature failure.
- 2.10 Mechanical Loads: External forces can significantly reduce Hose, Tube and Fitting life or cause failure. Mechanical loads which must be considered include excessive flexing, twist, kinking, tensile or side loads, bend radius, and vibration. Use of swivel type Fittings or adapters may be required to insure no twist is put into the Hose. Use of proper Hose or Tube clamps may also be required to reduce external mechanical loads. Unusual applications may require special testing prior to Hose selection.

- 2.11 **Physical Damage:** Care must be taken to protect Hose from wear, snagging, kinking, bending smaller than minimum bend radius and cutting, any of which can cause premature Hose failure. Any Hose that has been kinked or bent to a radius smaller than the minimum bend radius, and any Hose that has been cut or is cracked or is otherwise damaged should be removed and discarded. Fittings with damages such as scratches on sealing surfaces and deformation should be replaced.
- 2.12 **Proper End Fitting:** See instructions 3.2 through 3.5. These recommendations may be substantiated by testing to industry standards such as SAE J517 for hydraulic applications, or MIL-A-5070, AS1339, or AS3517 for Hoses from Parker's Stratoflex Products Division for aerospace applications.
- 2.13 **Length:** When determining the proper Hose or Tube length of an assembly, be aware of Hose length change due to pressure, Tube length change due to thermal expansion or contraction, and Hose or Tube and machine tolerances and movement must be considered. When routing short hose assemblies, it is recommended that the minimum free hose length is always used. Consult the hose manufacturer for their minimum free hose length recommendations. Hose assemblies should be installed in such a way that any motion or flexing occurs within the same plane.
- 2.14 **Specifications and Standards:** When selecting Hose, Tube and Fittings, government, industry, and Parker specifications and recommendations must be reviewed and followed as applicable.
- 2.15 **Hose Cleanliness:** Hose and Tube components may vary in cleanliness levels. Care must be taken to insure that the Hose and Tube Assembly selected has an adequate level of cleanliness for the application.
- 2.16 **Fire Resistant Fluids:** Some fire resistant fluids that are to be conveyed by Hose or Tube require use of the same type of Hose or Tube as used with petroleum base fluids. Some such fluids require a special Hose, Tube, Fitting and Seal, while a few fluids will not work with any Hose at all. See instructions 2.5 and 1.5. The wrong Hose, Tube, Fitting or Seal may fail after a very short service. In addition, all liquids but pure water may burn fiercely under certain conditions, and even pure water leakage may be hazardous.
- 2.17 **Radiant Heat:** Hose and Seals can be heated to destruction without contact by such nearby items as hot manifolds or molten metal. The same heat source may then initiate a fire. This can occur despite the presence of cool air around the Hose or Seal. Performance of Tube and Fitting subjected to the heat could be degraded.
- 2.18 **Welding or Brazing:** When using a torch or arc welder in close proximity to hydraulic lines, the hydraulic lines should be removed or shielded with appropriate fire resistant materials. Flame or weld spatter could burn through the Hose or Seal and possibly ignite escaping fluid resulting in a catastrophic failure. Heating of plated parts, including Hose Fittings and adapters, above 450°F (232°C) such as during welding, brazing or soldering may emit deadly gases. Any elastomer seal on fittings shall be removed prior to welding or brazing, any metallic surfaces shall be protected after brazing or welding when necessary. Welding and brazing filler material shall be compatible with the Tube and Fitting that are joined.
- 2.19 **Atomic Radiation:** Atomic radiation affects all materials used in Hose and Tube assemblies. Since the long-term effects may be unknown, do not expose Hose or Tube assemblies to atomic radiation. Nuclear applications may require special Tube and Fittings.
- 2.20 **Aerospace Applications:** The only Hose, Tube and Fittings that may be used for in-flight aerospace applications are those available from Parker's Stratoflex Products Division. Do not use any other Hose or Fittings for in-flight applications. Do not use any Hose or Fittings from Parker's Stratoflex Products Division with any other Hose or Fittings, unless expressly approved in writing by the engineering manager or chief engineer of Stratoflex Products Division and verified by the user's own testing and inspection to aerospace industry standards.
- 2.21 **Unlocking Couplings:** Ball locking couplings or other Fittings with quick disconnect ability can unintentionally disconnect if they are dragged over obstructions, or if the sleeve or other disconnect member, is bumped or moved enough to cause disconnect. Threaded Fittings should be considered where there is a potential for accidental uncoupling.

3.0 HOSE AND FITTINGS ASSEMBLY AND INSTALLATION INSTRUCTIONS

- 3.1 **Component Inspection:** Prior to assembly, a careful examination of the Hose and Fittings must be performed. All components must be checked for correct style, size, catalog number, and length. The Hose must be examined for cleanliness, obstructions, blisters, cover looseness, kinks, cracks, cuts or any other visible defects. Inspect the Fitting and sealing surfaces for burrs, nicks, corrosion or other imperfections. Do NOT use any component that displays any signs of nonconformance.
- 3.2 **Hose and Fitting Assembly:** Do not assemble a Parker Fitting on a Parker Hose that is not specifically listed by Parker for that Fitting, unless authorized in writing by the engineering manager or chief engineer of the appropriate Parker division. Do not assemble a Parker Fitting on another manufacturer's Hose or a Parker Hose on another manufacturer's Fitting unless (i) the engineering manager or chief engineer of the appropriate Parker division approves the Assembly in writing or that combination is expressly approved in the appropriate Parker literature for the specific Parker product, and (ii) the user verifies the Assembly and the application through analysis and testing. For

Parker Hose that does not specify a Parker Fitting, the user is solely responsible for the selection of the proper Fitting and Hose Assembly procedures. See instruction 1.4. To prevent the possibility of problems such as leakage at the Fitting or system contamination, it is important to completely remove all debris from the cutting operation before installation of the Fittings. The Parker published instructions must be followed for assembling the Fittings on the Hose. These instructions are provided in the Parker Fitting catalog for the specific Parker Fitting being used, or by calling 1-800-CPARKER, or at www.parker.com.

- 3.3 Related Accessories: Do not crimp or swage any Parker Hose or Fitting with anything but the listed swage or crimp machine and dies in accordance with Parker published instructions. Do not crimp or swage another manufacturer's Fitting with a Parker crimp or swage die unless authorized in writing by the engineering manager or chief engineer of the appropriate Parker division.
- 3.4 Parts: Do not use any Parker Fitting part (including but not limited to socket, shell, nipple, or insert) except with the correct Parker mating parts, in accordance with Parker published instructions, unless authorized in writing by the engineering manager or chief engineer of the appropriate Parker division.
- 3.5 Field Attachable/Permanent: Do not reuse any field attachable Hose Fitting that has blown or pulled off a Hose. Do not reuse a Parker permanent Hose Fitting (crimped or swaged) or any part thereof. Complete Hose Assemblies may only be reused after proper inspection under section 4.0. Do not assemble Fittings to any previously used hydraulic Hose that was in service, for use in a fluid power application.
- 3.6 Pre-Installation Inspection: Prior to installation, a careful examination of the Hose Assembly must be performed. Inspect the Hose Assembly for any damage or defects. DO NOT use any Hose Assembly that displays any signs of nonconformance.
- 3.7 Minimum Bend Radius: Installation of a Hose at less than the minimum listed bend radius may significantly reduce the Hose life. Particular attention must be given to preclude sharp bending at the Hose to Fitting juncture. Any bending during installation at less than the minimum bend radius must be avoided. If any Hose is kinked during installation, the Hose must be discarded.
- 3.8 Twist Angle and Orientation: Hose Assembly installation must be such that relative motion of machine components does not produce twisting.
- 3.9 Securement: In many applications, it may be necessary to restrain, protect, or guide the Hose to protect it from damage by unnecessary flexing, pressure surges, and contact with other mechanical components. Care must be taken to insure such restraints do not introduce additional stress or wear points.
- 3.10 Proper Connection of Ports: Proper physical installation of the Hose Assembly requires a correctly installed port connection insuring that no twist or torque is transferred to the Hose when the Fittings are being tightened or otherwise during use.
- 3.11 External Damage: Proper installation is not complete without insuring that tensile loads, side loads, kinking, flattening, potential abrasion, thread damage or damage to sealing surfaces are corrected or eliminated. See instruction 2.10.
- 3.12 System Checkout: All air entrapment must be eliminated and the system pressurized to the maximum system pressure (at or below the Hose maximum working pressure) and checked for proper function and freedom from leaks. Personnel must stay out of potential hazardous areas while testing and using.
- 3.13 Routing: The Hose Assembly should be routed in such a manner so if a failure does occur, the escaping media will not cause personal injury or property damage. In addition, if fluid media comes in contact with hot surfaces, open flame or sparks, a fire or explosion may occur. See section 2.4.
- 3.14 Ground Fault Equipment Protection Devices (GFEPDs): WARNING! Fire and Shock Hazard. To minimize the danger of fire if the heating cable of a Multitube bundle is damaged or improperly installed, use a Ground Fault Equipment Protection Device. Electrical fault currents may be insufficient to trip a conventional circuit breaker. For ground fault protection, the IEEE 515: (www.ansi.org) standard for heating cables recommends the use of GFEPDs with a nominal 30 milliampere trip level for "piping systems in classified areas, those areas requiring a high degree of maintenance, or which may be exposed to physical abuse or corrosive atmospheres".

4.0 TUBE AND FITTINGS ASSEMBLY AND INSTALLATION INSTRUCTIONS

- 4.1 Component Inspection: Prior to assembly, a careful examination of the Tube and Fittings must be performed. All components must be checked for correct style, size, material, seal, and length. Inspect the Fitting and sealing surfaces for burrs, nicks, corrosion, missing seal or other imperfections. Do NOT use any component that displays any signs of nonconformance.
- 4.2 Tube and Fitting Assembly: Do not assemble a Parker Fitting with a Tube that is not specifically listed by Parker for that Fitting, unless authorized in writing by the engineering manager or chief engineer of the appropriate Parker division. The Tube must meet the requirements specified to the Fitting. The Parker published instructions must be followed for assembling the Fittings to a Tube. These instructions are provided in the Parker Fitting catalog for the specific Parker Fitting being used, or by calling 1-800-CPARKER, or at www.parker.com.
- 4.3 Related Accessories: Do not preset or flange Parker Fitting components using another manu-

- facturer's equipment or procedures unless authorized in writing by the engineering manager or chief engineer of the appropriate Parker division. Tube, Fitting component and tooling must be checked for correct style, size and material. Operation and maintenance of Related Accessories must be in accordance with the operation manual for the designated Accessory.
- 4.4 **Securement:** In many applications, it may be necessary to restrain, protect, or guide the Tube to protect it from damage by unnecessary flexing, pressure surges, vibration, and contact with other mechanical components. Care must be taken to insure such restraints do not introduce additional stress or wear points.
 - 4.5 **Proper Connection of Ports:** Proper physical installation of the Tube Assembly requires a correctly installed port connection insuring that no torque is transferred to the Tube when the Fittings are being tightened or otherwise during use.
 - 4.6 **External Damage:** Proper installation is not complete without insuring that tensile loads, side loads, flattening, potential abrasion, thread damage or damage to sealing surfaces are corrected or eliminated. See instruction 2.10.
 - 4.7 **System Checkout:** All air entrapment must be eliminated and the system pressurized to the maximum system pressure (at or below the Tube Assembly maximum working pressure) and checked for proper function and freedom from leaks. Personnel must stay out of potential hazardous areas while testing and using.
 - 4.8 **Routing:** The Tube Assembly should be routed in such a manner so if a failure does occur, the escaping media will not cause personal injury or property damage. In addition, if fluid media comes in contact with hot surfaces, open flame or sparks, a fire or explosion may occur. See section 2.4.

5.0 HOSE AND FITTING MAINTENANCE AND REPLACEMENT INSTRUCTIONS

- 5.1 **Even with proper selection and installation, Hose life may be significantly reduced without a continuing maintenance program.** The severity of the application, risk potential from a possible Hose failure, and experience with any Hose failures in the application or in similar applications should determine the frequency of the inspection and the replacement for the Products so that Products are replaced before any failure occurs. Certain products require maintenance and inspection per industry requirements. Failure to adhere to these requirements may lead to premature failure. A maintenance program must be established and followed by the user and, at minimum, must include instructions 5.2 through 5.7
- 5.2 **Visual Inspection Hose/Fitting:** Any of the following conditions require immediate shut down and replacement of the Hose Assembly:
 - Fitting slippage on Hose;
 - Damaged, cracked, cut or abraded cover (any reinforcement exposed);
 - Hard, stiff, heat cracked, or charred Hose;
 - Cracked, damaged, or badly corroded Fittings;
 - Leaks at Fitting or in Hose;
 - Kinked, crushed, flattened or twisted Hose; and
 - Blistered, soft, degraded, or loose cover.
- 5.3 **Visual Inspection All Other:** The following items must be tightened, repaired, corrected or replaced as required:
 - Leaking port conditions;
 - Excess dirt buildup;
 - Worn clamps, guards or shields; and
 - System fluid level, fluid type, and any air entrapment.
- 5.4 **Functional Test:** Operate the system at maximum operating pressure and check for possible malfunctions and leaks. Personnel must avoid potential hazardous areas while testing and using the system. See section 2.2.
- 5.5 **Replacement Intervals:** Hose assemblies and elastomeric seals used on Hose Fittings and adapters will eventually age, harden, wear and deteriorate under thermal cycling and compression set. Hose Assemblies and elastomeric seals should be inspected and replaced at specific replacement intervals, based on previous service life, government or industry recommendations, or when failures could result in unacceptable downtime, damage, or injury risk. See section 1.2. Hose and Fittings may be subjected to internal mechanical and/or chemical wear from the conveying fluid and may fail without warning. The user must determine the product life under such circumstances by testing. Also see section 2.5.
- 5.6 **Hose Inspection and Failure:** Hydraulic power is accomplished by utilizing high pressure fluids to transfer energy and do work. Hoses, Fittings and Hose Assemblies all contribute to this by transmitting fluids at high pressures. Fluids under pressure can be dangerous and potentially lethal and, therefore, extreme caution must be exercised when working with fluids under pressure and handling the Hoses transporting the fluids. From time to time, Hose Assemblies will fail if they are not replaced at proper time intervals. Usually these failures are the result of some form of misapplication, abuse, wear or failure to perform proper maintenance. When Hoses fail, generally the high pressure fluids inside escape in a stream which may or may not be visible to the user. Under no circumstances should the user attempt to locate the leak by "feeling" with their hands or any other part of their body. High pressure fluids can and will penetrate the skin and cause severe tissue dam-

age and possibly loss of limb. Even seemingly minor hydraulic fluid injection injuries must be treated immediately by a physician with knowledge of the tissue damaging properties of hydraulic fluid. If a Hose failure occurs, immediately shut down the equipment and leave the area until pressure has been completely released from the Hose Assembly. Simply shutting down the hydraulic pump may or may not eliminate the pressure in the Hose Assembly. Many times check valves, etc., are employed in a system and can cause pressure to remain in a Hose Assembly even when pumps or equipment are not operating. Tiny holes in the Hose, commonly known as pinholes, can eject small, dangerously powerful but hard to see streams of hydraulic fluid. It may take several minutes or even hours for the pressure to be relieved so that the Hose Assembly may be examined safely. Once the pressure has been reduced to zero, the Hose Assembly may be taken off the equipment and examined. It must always be replaced if a failure has occurred. Never attempt to patch or repair a Hose Assembly that has failed. Consult the nearest Parker distributor or the appropriate Parker division for Hose Assembly replacement information. Never touch or examine a failed Hose Assembly unless it is obvious that the Hose no longer contains fluid under pressure. The high pressure fluid is extremely dangerous and can cause serious and potentially fatal injury.

- 5.7 **Elastomeric seals:** Elastomeric seals will eventually age, harden, wear and deteriorate under thermal cycling and compression set. Elastomeric seals should be inspected and replaced.
- 5.8 **Refrigerant gases:** Special care should be taken when working with refrigeration systems. Sudden escape of refrigerant gases can cause blindness if the escaping gases contact the eye and can cause freezing or other severe injuries if it contacts any other portion of the body.
- 5.9 **Compressed natural gas (CNG):** Parker CNG Hose Assemblies should be tested after installation and before use, and at least on a monthly basis per instructions provided on the Hose Assembly tag. The recommended procedure is to pressurize the Hose and check for leaks and to visually inspect the Hose for damage and to perform an electrical resistance test. Caution: Matches, candles, open flame or other sources of ignition shall not be used for Hose inspection. Leak check solutions should be rinsed off after use.

6.0 HOSE STORAGE

- 6.1 **Age Control:** Hose and Hose Assemblies must be stored in a manner that facilitates age control and first-in and first-out usage based on manufacturing date of the Hose and Hose Assemblies. Unless otherwise specified by the manufacturer or defined by local laws and regulations:
 - 6.1.1 The shelf life of rubber hose in bulk form or hose made from two or more materials is 28 quarters (7 years) from the date of manufacture, with an extension of 12 quarters (3 years), if stored in accordance with ISO 2230;
 - 6.1.2 The shelf life of thermoplastic and polytetrafluoroethylene hose is considered to be unlimited;
 - 6.1.3 Hose assemblies that pass visual inspection and proof test shall not be stored for longer than 2 years.
- 6.1.4 **Storage:** Stored Hose and Hose Assemblies must not be subjected to damage that could reduce their expected service life and must be placed in a cool, dark and dry area with the ends capped. Stored Hose and Hose Assemblies must not be exposed to temperature extremes, ozone, oils, corrosive liquids or fumes, solvents, high humidity, rodents, insects, ultraviolet light, electromagnetic fields or radioactive materials.

Parker's Motion & Control Product Groups

At Parker, we're guided by a relentless drive to help our customers become more productive and achieve higher levels of profitability by engineering the best systems for their requirements. It means looking at customer applications from many angles to find new ways to create value. Whatever the motion and control technology need, Parker has the experience, breadth of product and global reach to consistently deliver. No company knows more about motion and control technology than Parker. For further info call 1 800 C-Parker (1 800 272 7537).



Aerospace

Key Markets
 Aftermarket services
 Commercial transports
 Engines
 General & business aviation
 Helicopters
 Launch vehicles
 Military aircraft
 Missiles
 Power generation
 Regional transports
 Unmanned aerial vehicles

Key Products
 Control systems & actuation products
 Engine systems & components
 Fluid conveying systems & components
 Fluid metering, delivery & automation devices
 Fuel systems & components
 Fuel tank inerting systems
 Hydraulic systems & components
 Thermal management
 Wheels & brakes



Automation

Key Markets
 Alternative energy
 Conveyor & material handling
 Factory automation
 Food & beverage
 Life sciences & medical
 Machine tools
 Packaging machinery
 Paper machinery
 Plastics machinery
 Primary metals
 Safety & security
 Semiconductor & electronics
 Transportation & automotive

Key Products
 A/D/C drives & systems
 Air preparation
 Electric actuators, gantry robots & slides
 Human machine interfaces
 Inverters
 Manifolds
 Mixature fluids
 Pneumatic actuators & grippers
 Pneumatic valves & controls
 Rotary actuators
 Stepper motors, servo motors, drives & controls
 Structural extrusions
 Vacuum generators, cups & sensors



Climate & Industrial Controls

Key Markets
 Agriculture
 Air conditioning
 Construction Machinery
 Food & beverage
 Industrial machinery
 Life sciences
 Oil & gas
 Precision cooling
 Process
 Refrigeration
 Transportation

Key Products
 Accumulators
 Advanced actuators
 CO₂ controls
 Electronic controllers
 Filter driers
 Hand shut-off valves
 Heat exchangers
 Hose & fittings
 Pressure regulating valves
 Refrigerant distributors
 Safety relief valves
 Smart pumps
 Solenoid valves
 Thermostatic expansion valves



Filtration

Key Markets
 Aerospace
 Food & beverage
 Industrial plant & equipment
 Life sciences
 Marine
 Mobile equipment
 Oil & gas
 Power generation & renewable energy
 Process
 Transportation
 Water Purification

Key Products
 Analytical gas generators
 Compressed air filters & dryers
 Engine air, coolant, fuel & oil filtration systems
 Fluid condition monitoring systems
 Hydraulic & lubrication filters
 Hydrogen, nitrogen & zero air generators
 Instrumentation filters
 Membrane & fiber filters
 Microfiltration
 Sterile air filtration
 Water desalination & purification filters & systems



Fluid Connectors

Key Markets
 Aerial lift
 Agriculture
 Bulk chemical handling
 Construction machinery
 Food & beverage
 Fuel & gas delivery
 Industrial machinery
 Life sciences
 Marine
 Mining
 Mobile
 Oil & gas
 Renewable energy
 Transportation

Key Products
 Check valves
 Connectors for low pressure
 Fluid conveyance
 Deep sea umbilicals
 Diagnostic equipment
 Hose couplings
 Industrial hose
 Mooring systems & power cables
 PTFE hose & tubing
 Quick couplings
 Rubber & thermoplastic hose
 Tube fittings & adapters
 Tubing & plastic fittings



Hydraulics

Key Markets
 Agriculture
 Alternative energy
 Construction machinery
 Forestry
 Industrial machinery
 Machine tools
 Marine
 Material handling
 Mining
 Oil & gas
 Power generation
 Refuse vehicles
 Renewable energy
 Truck hydraulics
 Turf equipment

Key Products
 Accumulators
 Cartridge valves
 Electrohydraulic actuators
 Hybrid drives
 Hydraulic cylinders
 Hydraulic motors & pumps
 Hydraulic systems
 Hydraulic valves & controls
 Hydrostatic steering
 Integrated hydraulic circuits
 Power take-offs
 Power units
 Rotary actuators
 Sensors



Instrumentation

Key Markets
 Alternative fuels
 Biopharmaceuticals
 Chemical & refining
 Food & beverage
 Marine & shipbuilding
 Medical & dental
 Microelectronics
 Nuclear Power
 Offshore oil exploration
 Oil & gas
 Pharmaceuticals
 Power generation
 Pulp & paper
 Steel
 Water/wastewater

Key Products
 Analytical Instruments
 Analytical sample conditioning systems & systems
 Chemical injection fittings & valves
 Fluoropolymer chemical delivery fittings, valves & pumps
 High purity gas delivery fittings, valves, regulators & digital flow controllers
 Industrial mass flow meters/controllers
 Permanent no-weld tube fittings
 Precision industrial regulators & flow controllers
 Process control double block & bleed
 Process control fittings, valves, regulators & manifold valves



Seal

Key Markets
 Aerospace
 Chemical processing
 Consumer
 Fluid power
 General industrial
 Information technology
 Life sciences
 Microelectronics
 Military
 Oil & gas
 Power generation
 Renewable energy
 Telecommunications
 Transportation

Key Products
 Dynamic seals
 Electronic O-rings
 Electro-medical instrument design & assembly
 EMI shielding
 Extruded & precision-cut, tapered electronic seals
 High temperature metal seals
 Homogeneous & inserted elastomeric shapes
 Medical device fabrication & assembly
 Metal & plastic retained composite seals
 Shielded optical windows
 Silicone tubing & extrusions
 Thermal management
 Vibration dampening



Parker Fluid Connectors Group North American Divisions & Distribution Service Centers

Your complete source for quality tube fittings, hose & hose fittings, brass & composite fittings, quick-disconnect couplings, valves and assembly tools, locally available from a worldwide network of authorized distributors.

Fittings:

Available in inch and metric sizes covering SAE, BSP, DIN, GAZ, JIS and ISO thread configurations, manufactured from steel, stainless steel, brass, aluminum, nylon and thermoplastic.

Hose, Tubing and Bundles:

Available in a wide variety of sizes and materials including rubber, wire-reinforced, thermoplastic, hybrid and custom compounds.

Worldwide Availability:

Parker operates Fluid Connectors manufacturing locations and sales offices throughout North America, South America, Europe and Asia-Pacific.

For information, call toll free...
1-800-C-PARKER (1-800-272-7537)

North American Divisions

Fluid System Connectors Division

Otsego, MI
phone 269 692 6555
fax 269 694 4614

Engineering Support:

FSC.Apps@support.parker.com

Customer Support:

FSC.Support@support.parker.com

Quote Support:

FSC.Quotes@support.parker.com

Hose Products Division

Wickliffe, OH
phone 440 943 5700
fax 440 943 3129

Parflex Division

Ravenna, OH
phone 330 296 2871
fax 330 296 8433

Quick Coupling Division

Minneapolis, MN
phone 763 544 7781
fax 763 544 3418

Tube Fittings Division

Columbus, OH
phone 614 279 7070
fax 614 279 7685

Distribution Service Centers

Buena Park, CA

phone 714 522 8840
fax 714 994 1183

Conyers, GA

phone 770 929 0330
fax 770 929 0230

Louisville, KY

phone 502 937 1322
fax 502 937 4180

Portland, OR

phone 503 283 1020
fax 503 283 2201

Toledo, OH

phone 419 878 7000
fax 419 878 7001
419 878 7420
(FCG Kit Operations)

Canada

Milton, ONT

phone 905 693 3000
fax 905 876 1958

Mexico Toluca, MEX

phone (52) 722 2754 200
fax (52) 722 2722 168

