



**EXOTIC**  
AUTOMATION & SUPPLY

**Custom Fluid Transfer & Metering Solutions**

**Customizable Solutions**

Exotic's custom built systems offer bulk fluid farm transfer filtration to point of process duplex filtration for uninterrupted production metered output.

Exotic builds systems that provide both standard and customizable configurations, with flow rates from 2 -126 liters per minute.

Accurate fluid dispense control reduces cost and wasted resources. Exotic works with your team to design Fluid Delivery, Transfer and Evacuation Systems - based on your specific application requirements.

Contact us to learn how we can help you maximize your return on investment!

**System Specifications**

<b>Energy Source</b>	Pneumatic, Electric
<b>Nozzles</b>	Single, Double
<b>Power</b>	3 - 10 hp
<b>Porting</b>	BSPP, NPT, SAE
<b>Material</b>	Steel, Stainless Steel
<b>Tank Size (Gallons)</b>	30, 40, 60, 100, 200, 500
<b>Sensors</b>	Flow, Pressure, Level, Temp.
<b>Filtration</b>	Duplex
<b>Flow Meters</b>	Pulse, Coriolis



# Reliable, Repeatable Dispensing Volumes

## Multiple Fluid Sensor Options

- ◆ Temperature
- ◆ Pressure
- ◆ Level
- ◆ Flow



## Pneumatic

*Pressure set point allows stall without heater or cooler*

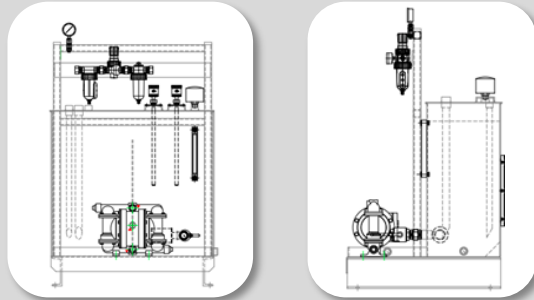

*Dual pump pressure set point allows stall, single Coriolis feedback without heater or cooler*

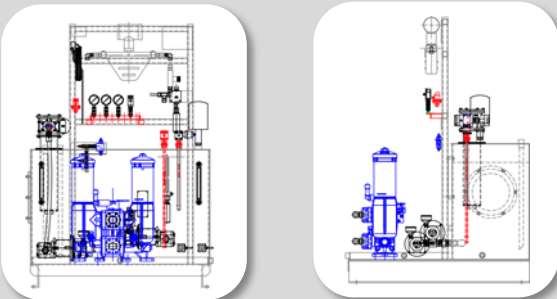

## Electric

*Fixed speed pressure compensated, dual coriolis feedback output with heater & cooler*

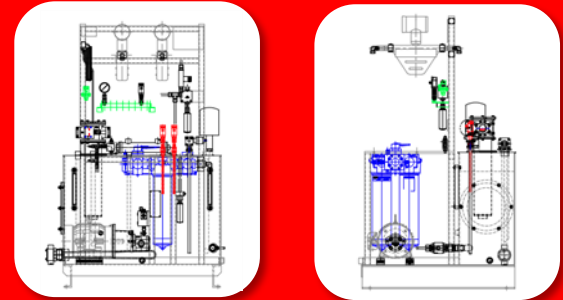

*Variable speed temperature control with heater & cooler*

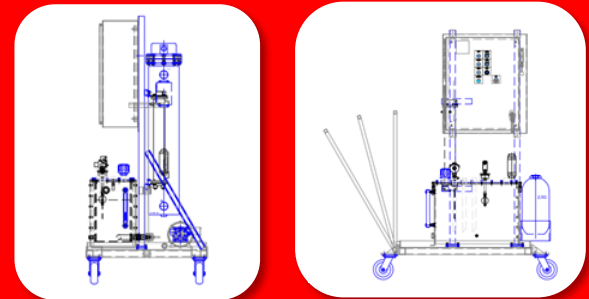

## Value-Added Services

- ◆ Technical, Product Application Support
- ◆ System Design & Engineering
- ◆ Full Service Build Capabilities
- ◆ Assembly, Test & Documentation
- ◆ Kitting



53500 Grand River Ave  
New Hudson, MI 48165  
(248) 477-2122  
sales@erpc.com

[www.exoticautomation.com](http://www.exoticautomation.com)

