

Pressure & Level Measurement Solutions



Pressure Gauges
Dial Indicating
Differential
Sanitary
Digital

Pressure & Level
Transducers &
Transmitters
Industrial
OEM
Hazardous Location
Sanitary



Pressure Switches

Options & Accessories



At NOSHOK, we pride ourselves on being innovators in the industry by continually offering the latest technology and measurement solutions, and providing the best customer support in the marketplace.

Established in 1967, NOSHOK was one of the first companies to offer liquid filled pressure gauges. We also took a bold step by backing our quality gauges with an extended 3-year warranty. That unwavering standard of quality has endured for over 45 years, and as we have expanded our product offering we continue to provide industry-leading warranties. NOSHOK also leads the industry as one of the first companies to offer corrosion-resistant zinc nickel plating standard on our carbon steel valves.

We have the capacity to put together special requirements which are so often hard to find. If you do not find what you need in this catalog, chances are we can still put a solution together.

NOSHOK is committed to providing excellence on every level. Thank you for choosing NOSHOK products.

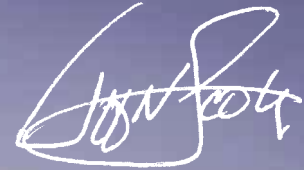

Jeff N. Scott
President



NOSHOK Corporate Headquarters
Your Single Source Instrumentation Company

NOSHOK is a member and actively supports:



NOSHOK is an ISO 9001:2008 registered company.

WARRANTY INFORMATION

NOSHOK's **Three Year Warranty** applies to our 300, 500, 660, 760, and 900 Series liquid filled gauges; 10 and 20 Series liquid filled sanitary gauges; 1000 Series digital gauge; 1000, 1100, 1200, and 1300 Series liquid filled differential gauges; 100, 200, 300, 612, 613, 615/616, 619/620, 621/622, 623/624, 625/626, 627, 640, 650, 660 and 800 Series transmitters & transducers; 11 and 21 Series sanitary transmitters; and 500, 800, 810 Series electronic switch products.

Our **One Year Warranty** applies to our 100, 200, 400, 640, 740, and 800 Series dry gauges; 10 and 20 Series dry sanitary gauges; 1000, 1100, 1200, and 1300 Series dry differential gauges; 100, 200, 300 and 400 Series mechanical switch products, and 628 Series intrinsically safe hammer union transmitter.

NOSHOK guarantees all products to be free from defects in material and workmanship, to remain within catalogued accuracy specifications, and to operate within the catalogued performance specifications. These products must be operated within the catalogued environmental and application parameters. Determination of failure will be made by NOSHOK, Inc.'s equipment and personnel or a certified test facility specializing in this type of evaluation. Instrument failures determined to be caused by over-range, incompatibility with environment or product media and abuse will not be considered under this warranty. NOSHOK, Inc. will, at its discretion, repair or replace the instrument without cost to the customer.

Limitations which apply are: Bourdon tube pressure gauges must be used within their calibrated maximum range to prevent damage. Pressure gauges must be operated within the following working pressure limits: Dynamic pressure application, 60% of the dial range; Static pressure applications, where no sharp fluctuations occur, 90% of the dial range. The gauges must be operated within specified ambient temperature ranges.

CAUTION:

Operating conditions including, but not limited to, system pressure, media compatibility and ambient conditions must be considered when selecting gauges and accessories, improper selections and use of gauges could possibly cause gauge failure and lead to possible property damage or personal injury. Refer to the American National Standard ASME B40.1 for the correct selection and use of dial indicating gauges.

T A B L E O F C O N T E N T S



DIAL INDICATING PRESSURE GAUGES

ABS & Steel Case, Dry: 100 SERIES	6-9
Low Pressure Diaphragm: 200 SERIES	10-13
Brass Case, Liquid Filled: 300 SERIES	14-17
All Stainless Steel, Dry & Liquid Filled: 400/500 SERIES	18-21
Process: 600/700 SERIES	22-23
Precision Test: 800 SERIES	24-25
ABS & Stainless Steel Case, Liquid Filled: 900 SERIES	26-29



T A B L E O F C O N T E N T S

DIFFERENTIAL PRESSURE GAUGES

Piston Type: 1000 SERIES	30-31
Diaphragm Type: 1100 SERIES	32-33
Membrane Type High Static Pressure: 1200 SERIES	34-35
Membrane Type Nominal Static Pressure: 1300 SERIES	36-37
Dial Layouts: 1000, 1100, 1200 & 1300 SERIES	38-39

SANITARY PRESSURE GAUGES

Fractional: 10 SERIES	40-41
Heavy-Duty: 10 SERIES	42-43
Homogenizer: 20 SERIES	44-45

DIAL INDICATING PRESSURE GAUGE OPTIONS & ACCESSORIES

Panel Mounting Flanges, Cases & Cover Rings, Lenses, Maximum Indicating Pointer, Set Pointers, Rubber Case Protectors, Recalibrators & Adjustable Pointers, Overpressure Protection, Ammonia Refrigeration Gauges, Liquid Filling Options, Special Connections, Reid Vapor Test Gauges, Receiver Gauges, Metric Dials & Customized Special Dials, Certified Calibration, Magnetic Spring Contact Switch	46-49
Options & Accessories by Gauge Series	50-53
Gauge Fill Options	53
Accuracy/Standard Dial Configurations	54-59

DIGITAL PRESSURE GAUGE

Digital Gauge: 1000 SERIES	60-61
-------------------------------------	-------

INDUSTRIAL PRESSURE & LEVEL TRANSMITTERS & TRANSDUCERS

Current Output: 100 SERIES	62-63
Voltage Output: 200 SERIES	64-65
Submersible Level: 612 SERIES	66-67
Cage-Protected Submersible Level: 613 SERIES	68-69
High Accuracy: 615/616 SERIES	70-71
Precision: 640 SERIES	72-73
Micro-sized: 660 SERIES	74-75
Electronic Indicating Pressure Transmitter/Switch: 800/810 SERIES	76-77

T A B L E O F C O N T E N T S



OEM TRANSMITTERS & TRANSDUCERS

Compact: 300 SERIES	78-79
High Volume: 650 SERIES	80-81

HAZARDOUS LOCATION PRESSURE & LEVEL TRANSMITTERS

ATEX-Approved Explosion-Proof: 619/620 SERIES	82-83
Explosion-Proof: 621/622 SERIES	84-85
Non-Incendive: 623/624 SERIES	86-87
Intrinsically Safe: 625/626 SERIES	88-89
Intrinsically Safe Submersible Level: 627 SERIES	90-91
Intrinsically Safe Hammer Union: 628 SERIES	92-93

SANITARY PRESSURE TRANSMITTERS

ASME-BPE Sanitary Clamp: 11 SERIES	94-95
Homogenizer: 21 SERIES	96-97

PRESSURE SWITCHES

Mechanical Miniature Low Pressure: 100 SERIES	98-99
Mechanical Compact SPDT: 200 SERIES	100-101
Mechanical Compact SPDT with Adjustable Hysteresis: 300 SERIES	102-103
Mechanical Heavy-Duty: 400 SERIES	104-105
Electronic Mag-Switch: 500 SERIES	106-107
Electronic Indicating Pressure Transmitter/Switch: 800/810 SERIES	108-109

ALL PRESSURE MEASUREMENT INSTRUMENTATION OPTIONS & ACCESSORIES

Certified Calibration, Piston-Type Snubbers, Sintered Snubbers, Pigtail Steam Syphons, Swivel Adaptors	110-113
Reference Information	114-125
Frequently Asked Questions	126-128
Canadian Registration Numbers	129

ABS & Steel Case, Dry



100 SERIES

- General purpose non-fillable dry gauge
- Vacuum and compound ranges through 0 psi to 15,000 psi
- 1-1/2", 2", 2-1/2" and 4" gauge sizes
- Standard impact-resistant ABS & steel case
- Copper alloy and brass wetted parts

OPERATING SPECIFICATIONS

1. Working Pressure Limitations

a. Dynamic Pressure

The working pressure should be limited to 60% of the dial range.

b. Static Pressure

The working pressure, where no sharp fluctuations occur, should be limited to 90% of the dial range

APPLICATIONS

- Hydraulics & pneumatics
- Medical
- Pumps & compressors
- Refrigeration controls
- Utilities
- Water management

	SERIES	SPECIFICATIONS
Pressure ranges	100 Series (all)	Vacuum and compound ranges through 0 psi to 15,000 psi
Accuracy	15-100, 15-110, 15-120, 20-100, 20-110, 20-120, 20-148, 25-100, 25-110, 25-120	±2.5% full scale
	40-100	±1.6% full scale
Temperature ranges*	100 Series (all)	Media -4 °F to 140 °F (-20 °C to 60 °C) Ambient -40 °F to 140 °F (-40 °C to 60 °C)
Measuring element	100 Series (all)	Copper alloy Bourdon tube
Connection	15-100, 15-110, 15-120, 20-100, 20-110	1/8" NPT, brass
	20-148	1/8" NPT/10-32 Female, brass
	20-100, 20-110, 20-120, 25-100, 25-110, 25-120, 40-100	1/4" NPT brass SAE J1926-3:7/16-20
Case	15-100, 15-110, 20-100, 20-110, 20-148, 25-100, 40-100	ABS (Acryl Nitril Butadien Styrol)
	15-120, 20-120, 25-120	Black painted steel with chrome triangular bezel and U-clamp
Bezel	15-110, 20-110, 25-110	Built-in bezel, molded as an integral part of the case for ease of panel mounting.
	15-120, 20-120, 25-120	Chrome-plated steel triangular bezel
Lens	100 Series (all)	Acrylic
Pointer	100 Series (all)	Molded plastic
Dial	100 Series (all)	White background with black primary scale & red secondary scale. UV resistant.
Movement	100 Series (all)	Brass & nylon, or all-brass with highly polished bearing surfaces

* For every 18 °F (10 °C) shift in temperature from which the gauge is calibrated, the user can experience up to ±0.4% additional error.

For details on accuracy/standard dial configuration and dial layouts, see pages 54-59.

ORDERING INFORMATION								
GAUGE SIZES	15 1-1/2"		20 2"		25 2-1/2"		40 4"	
CASE TYPES	100 ABS, bottom connection		120 Steel case panel mount					
	110 ABS, back connection		148 Square ABS, panel mount (2" only)					
PRESSURE RANGES	30vac -30 inHg vacuum to 0 psi		30/300 -30 inHg to 0 to 300 psi		200 0 psi to 200 psi		2000 0 psi to 2,000 psi	
	30/15 -30 inHg to 0 to 15 psi		15 0 psi to 15 psi		300 0 psi to 300 psi		3000 0 psi to 3,000 psi	
	30/30 -30 inHg to 0 to 30 psi		30 0 psi to 30 psi		400 0 psi to 400 psi		5000 0 psi to 5,000 psi	
	30/60 -30 inHg to 0 to 60 psi		60 0 psi to 60 psi		600 0 psi to 600 psi		6000 0 psi to 6,000 psi	
	30/100 -30 inHg to 0 to 100 psi		100 0 psi to 100 psi		1000 0 psi to 1,000 psi		10000 0 psi to 10,000 psi	
	30/160 -30 inHg to 0 to 160 psi		160 0 psi to 160 psi		1500 0 psi to 1,500 psi		15000 0 psi to 15,000 psi	
	30/200 -30 inHg to 0 to 200 psi		Other ranges available on request					
SCALE OPTIONS***	psi psi single scale		psi/kPa psi/kPa dual scale		psi/kg/cm ² psi/kg/cm ² dual scale		psi/bar psi/bar dual scale	
CONNECTION SIZES	1/8 1/8" NPT		SST SAE J1926-3:7/16-20 Adjustable		1/4 1/4" NPT			
OPTIONS	PMC Panel Mount Clamp		SSC Stainless Steel Case		LL Polycarbonate Lens		ST Stainless Steel Tagging	
	SSB Polished Stainless Steel Bezel		CRC Chrome Case		GL Glass Lens*		CPO Brass Sintered Orifice 20 Micron	
	BLRF Black Rear Flange		FAC Flat Sided ABS Case		SG Safety Glass Lens*		BP1 Brass Press Fit Orifice 0.1 mm	
	BLFF Black Front Flange – ABS Case		BCR Black Cover Ring**		HL Homalite Lens*		BP3 Brass Press Fit Orifice 0.3 mm	
	CFF Chrome Front Flange – ABS Case		SSCR Stainless Steel Cover Ring**		SP Red Set Pointer**		BP8 Brass Press Fit Orifice 0.8 mm	
	SBFF Black Front Flange – Steel Case		CCR Chrome Cover Ring**		MIP Maximum Indicating Pointer			
	SCFF Chrome Front Flange – Steel Case		PCCR Polished Chrome Cover Ring**		SDM Silicone Dampened Movement			
	BSC Black Steel Case		CAR Chrome Adapter Ring*		LM Laser Marking			

Please consult your local NOSHOK Distributor or NOSHOK, Inc. for availability and delivery information.

NOTE: Refer to 100 Series options & accessories chart on page 50 for availability by part number.

* A steel, stainless or chrome case & cover ring must be additionally ordered when lenses other than acrylic are utilized on all 100 Series.

** Only 110 Series require a steel, stainless or chrome case & cover ring to be additionally ordered when utilizing a set pointer or cover ring. Please consult factory when a set pointer is to be utilized on a 120 Series.

*** Other scales available on request

EXAMPLE

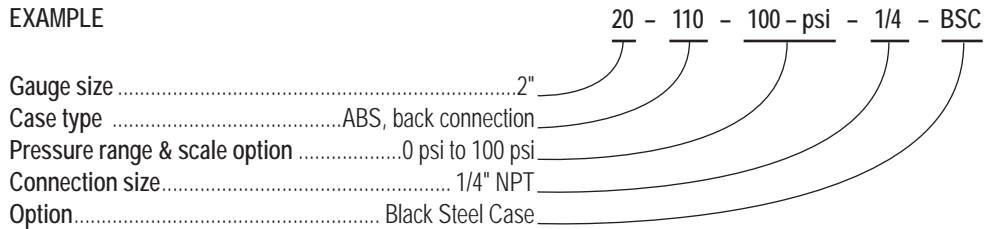

15-100

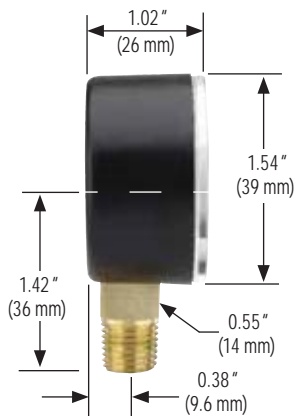

20-100

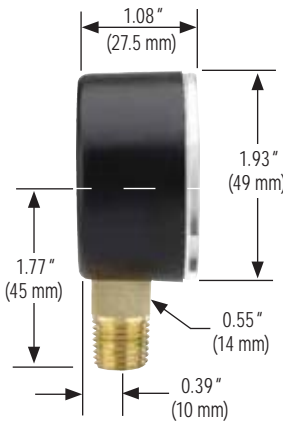

25-100

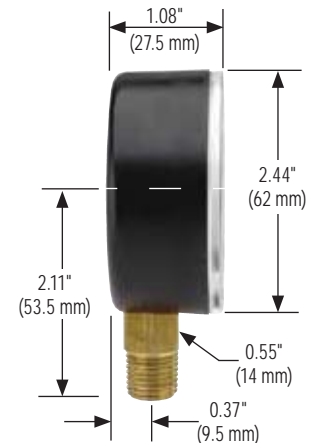

Dimensions

40-100

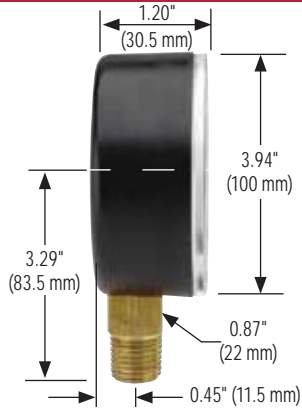

15-110

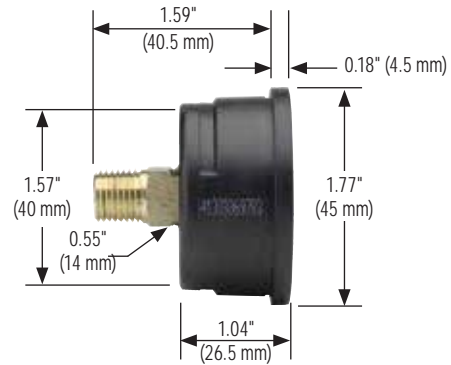

20-110

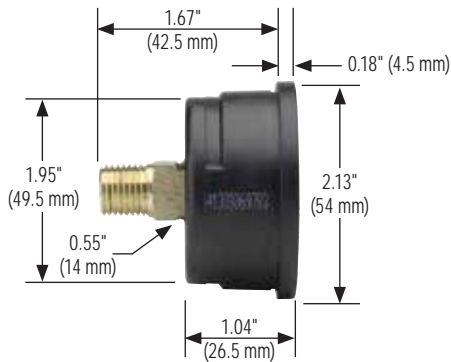

20-148

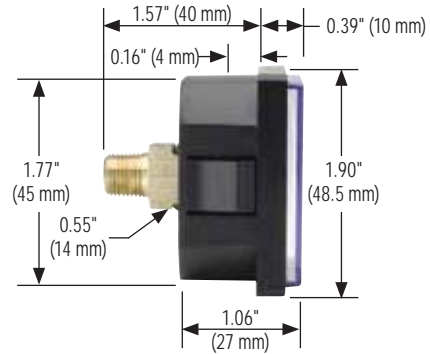

25-110

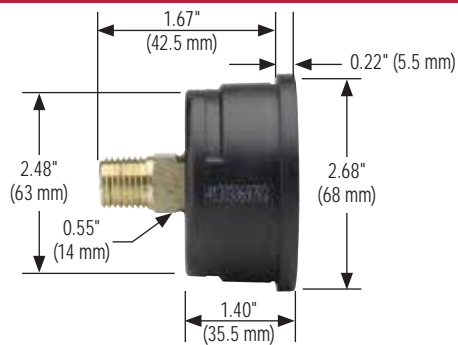

15-110 Front Flange

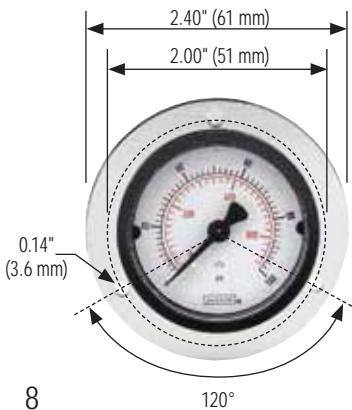

20-110 Front Flange

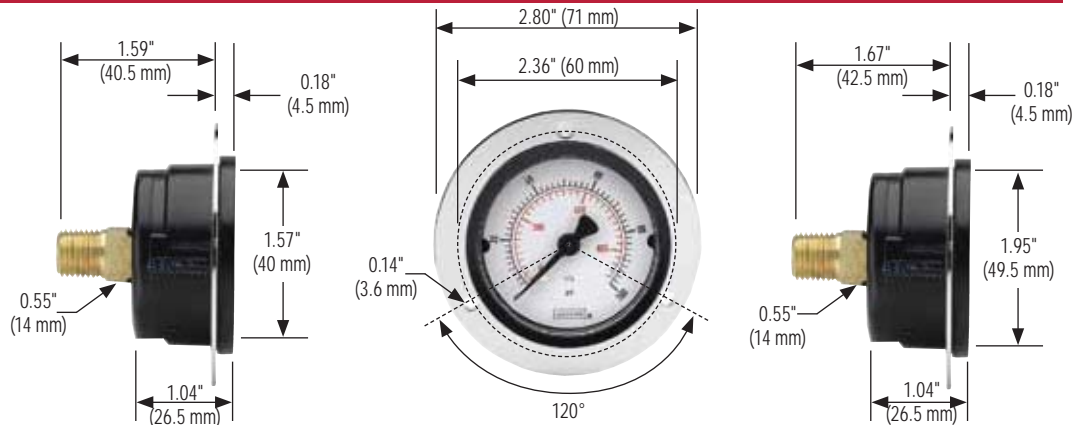

25-110 Front Flange

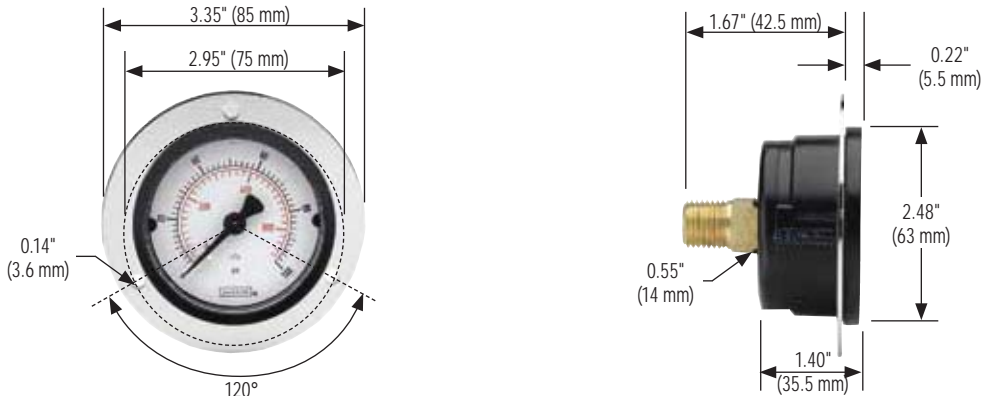

25-100 Rear Flange

40-100 Rear Flange

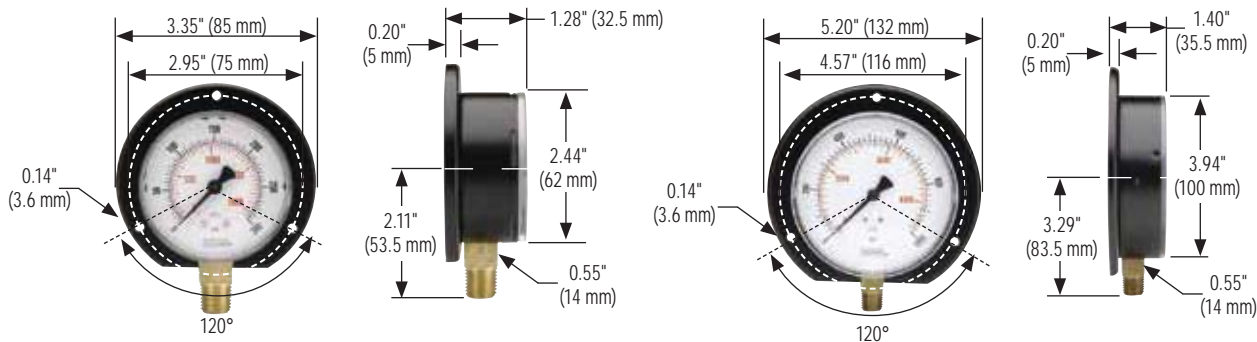

15-120 Chrome Bezel With U-Clamp

20-120 Chrome Bezel With U-Clamp

25-120 Chrome Bezel With U-Clamp

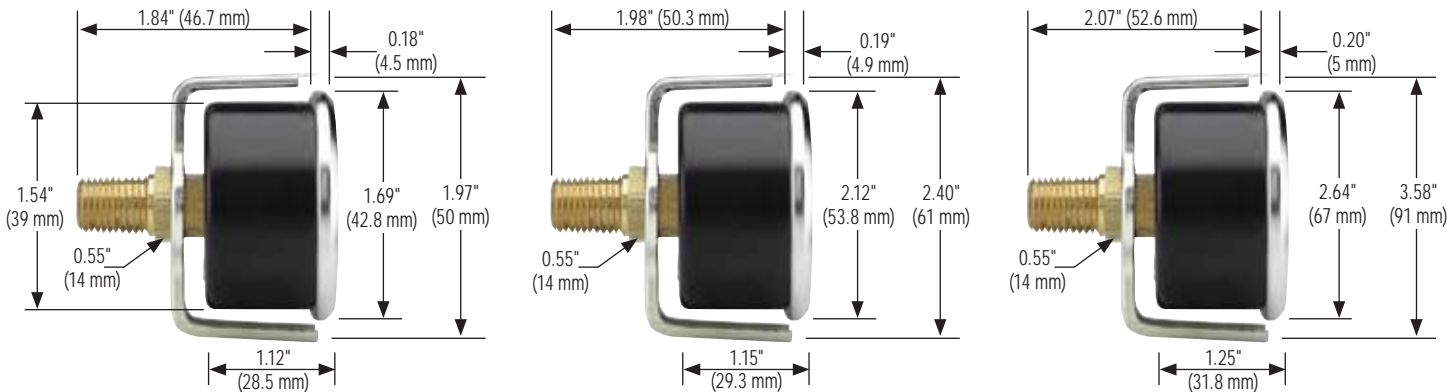

15-110 Panel Mount Clamp

20-110 Panel Mount Clamp

25-110 Panel Mount Clamp

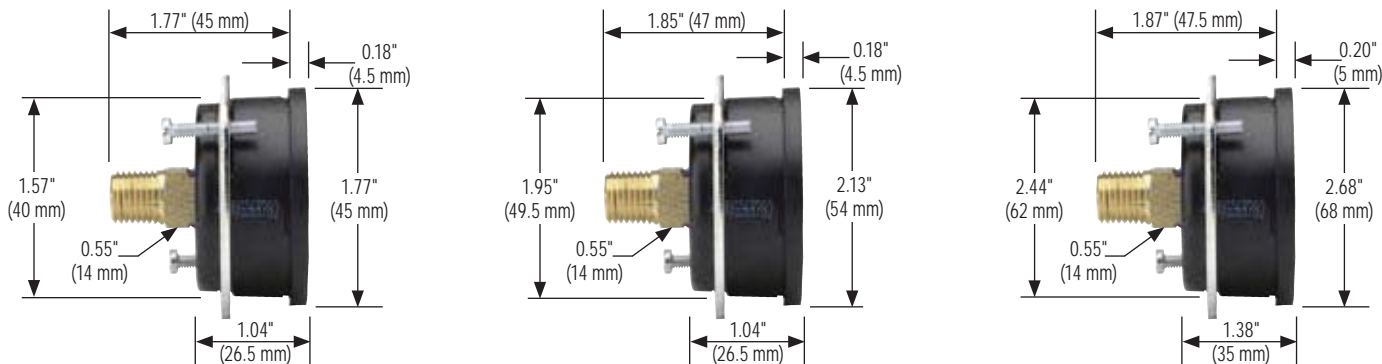

Low Pressure Diaphragm



200 SERIES

- Sensitive capsule-type, non-fillable dry gauge
- Vacuum ranges through 0 psi to 10 psi
- 2-1/2" and 4" gauge sizes
- Black painted steel, stainless steel and impact-resistant ABS case
- Copper alloy and brass wetted parts

OPERATING SPECIFICATIONS

1. Working Pressure Limitations

a. Dynamic Pressure

The working pressure should be limited to 60% of the dial range.

b. Static Pressure

The working pressure, where no sharp fluctuations occur, should be limited to 90% of the dial range

APPLICATIONS

- Filter monitoring
- Gas distribution
- HVAC
- Leak detection
- Level indication
- Medical

	SERIES	SPECIFICATIONS
Pressure ranges	200 Series (all)	Extreme low pressure vacuum ranges through 0 psi to 10 psi
Accuracy	25-200, 25-210, 25-224	±1.6% full scale
	25-206, 25-216	±2.5% full scale
	40-200	±1.6% full scale; optional ±1% full scale
Temperature ranges*	200 Series (all)	Media -4 °F to 176 °F (-20 °C to 80 °C) Ambient -4 °F to 140 °F (-20 °C to 60 °C)
Measuring element	25-200, 25-210, 25-224, 40-200	Copper alloy diaphragm capsule
Connection	200 Series (all)	1/4" NPT, brass
Case	25-200, 25-210	Black painted steel
	25-206, 25-216, 25-224	Black ABS (Acryl Nitril Butadien Styrol) with 25-224 includes zinc-plated steel panel mount clamp
	40-200	304 Stainless steel
Bezel	40-200	304 Stainless steel
Lens	25-200, 25-206, 25-210, 25-216, 25-224	Acrylic
	40-200	Instrument glass
Pointer	200 Series (all)	Black finished aluminum
Dial	200 Series (all)	Aluminum, white background with black scale. UV resistant.
Movement	25-200, 25-210, 25-224, 40-200	Brass and nickel-silver with highly polished bearing surfaces
	25-206, 25-216	Cu-Alloy

* For every 18 °F (10 °C) shift in temperature from which the gauge is calibrated, the user can experience up to ±0.4% additional error.

For details on accuracy/standard dial configuration and dial layouts, see pages 54-59.

ORDERING INFORMATION								
GAUGE SIZES	25 2-1/2"		40 4"					
CASE TYPES	200 Steel, bottom connection (304SS for 4")			216 ABS, back connection				
	206 ABS, bottom connection			224 ABS, panel mount				
	210 Steel, back connection			234 Gas pressure test kit**				
PRESSURE RANGES	15 inH ₂ O Vac	-15 inH ₂ O to 0 inH ₂ O	100 inH ₂ O	0 inH ₂ O to 100 inH ₂ O	100 oz/in ²	0 oz/in ² to 100 oz/in ²	60 mbar	0 mbar to 60 mbar
	30 inH ₂ O Vac	-30 inH ₂ O to 0 inH ₂ O	160 inH ₂ O	0 inH ₂ O to 160 inH ₂ O	160 oz/in ²	0 oz/in ² to 160 oz/in ²	100 mbar	0 mbar to 100 mbar
	60 inH ₂ O Vac	-60 inH ₂ O to 0 inH ₂ O	200 inH ₂ O	0 inH ₂ O to 200 inH ₂ O	20 oz/in ² /inH ₂ O	0 oz/in ² /inH ₂ O to 20 oz/in ² /inH ₂ O	160 mbar	0 mbar to 160 mbar
	100 inH ₂ O Vac	-100 inH ₂ O to 0 inH ₂ O	10 oz/in ²	0 oz/in ² to 10 oz/in ²	32 oz/in ² /inH ₂ O	0 oz/in ² /inH ₂ O to 32 oz/in ² /inH ₂ O	250 mbar	0 mbar to 250 mbar
	10 inH ₂ O	0 inH ₂ O to 10 inH ₂ O	15 oz/in ²	0 oz/in ² to 15 oz/in ²	3 psi	0 psi to 3 psi	400 mbar	0 mbar to 400 mbar
	15 inH ₂ O	0 inH ₂ O to 15 inH ₂ O	30 oz/in ²	0 oz/in ² to 30 oz/in ²	5 psi	0 psi to 5 psi	600 mbar	0 mbar to 600 mbar
	30 inH ₂ O	0 inH ₂ O to 30 inH ₂ O	35 oz/in ²	0 oz/in ² to 35 oz/in ²	10 psi	0 psi to 10 psi		
	60 inH ₂ O	0 inH ₂ O to 60 inH ₂ O	60 oz/in ²	0 oz/in ² to 60 oz/in ²	40 mbar	0 mbar to 40 mbar		
CONNECTION SIZE	1/4 1/4" NPT							
OPTIONS	BLRF	Black Rear Flange	GL	Glass Lens*	OP	Over Pressure Protection	CCR	Chrome Cover Ring
	SSRF	304SS Rear Flange	SG	Safety Glass Lens*	SSBU	Stainless Steel Bezel & U-Clamp	LM	Laser Marking
	BLFF	Black Front Flange	PL	Acrylic Lens	BBU	Black Bezel & U-Clamp	ST	Stainless Steel Tagging
	SSFF	304SS Front Flange	RL	Recalibrator Lens	BCR	Black Cover Ring	BP3	Brass Press Fit Orifice 0.3 mm
	CFF	Chrome Front Flange	SP	Red Set Pointer	SSCR	Stainless Steel Cover Ring	BT3	Brass Threaded Orifice 0.3 mm
	SSC	Stainless Steel Case	MIP	Maximum Indicating Pointer				

Please consult your local NOSHOK Distributor or NOSHOK, Inc. for availability and delivery information.

NOTE: Refer to 200 Series Options & Accessories chart on page 51 for availability by part number.

* A steel, stainless or chrome cover ring must be additionally ordered when lenses other than acrylic are utilized on all 200 Series

** Only available in 2-1/2" size, 20 oz/35 inH₂O

EXAMPLE

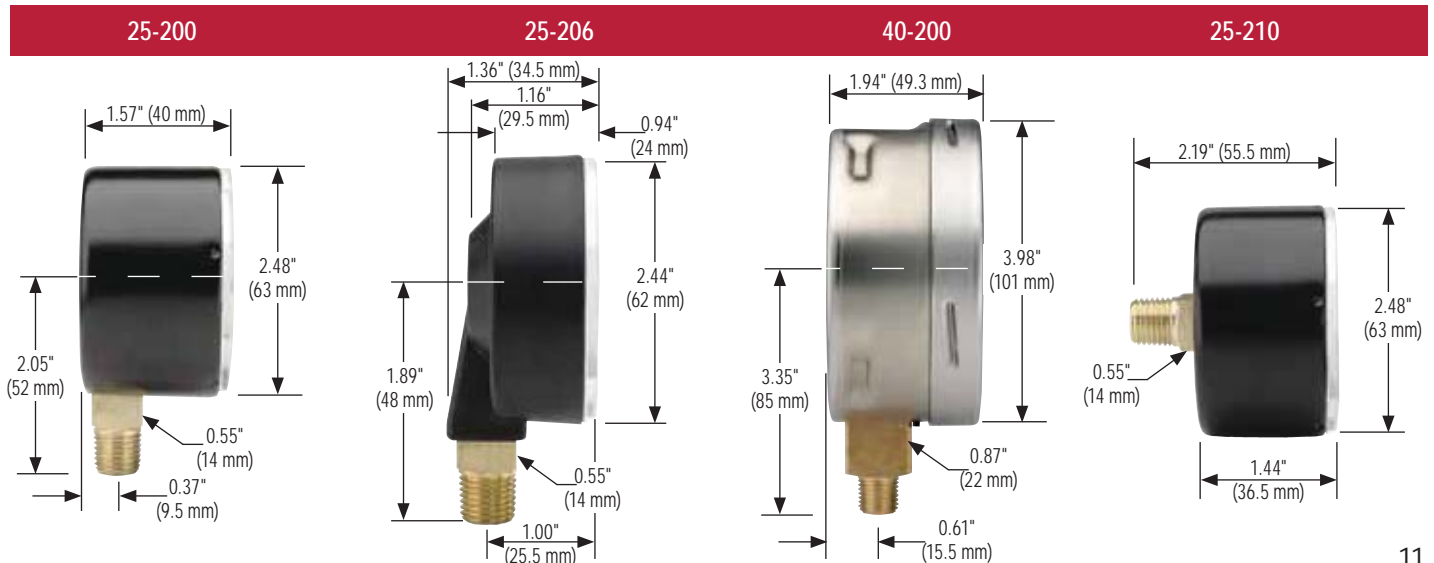
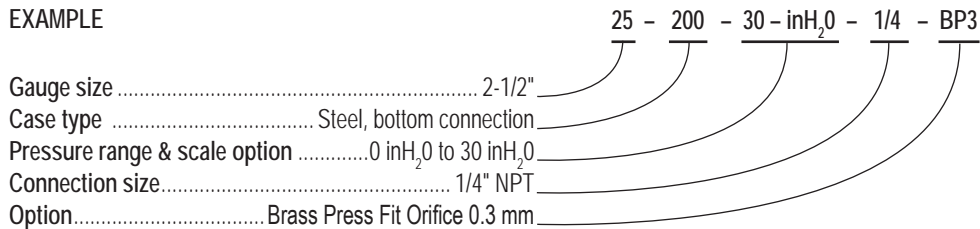

Dimensions

25-216

25-210 Front Flange

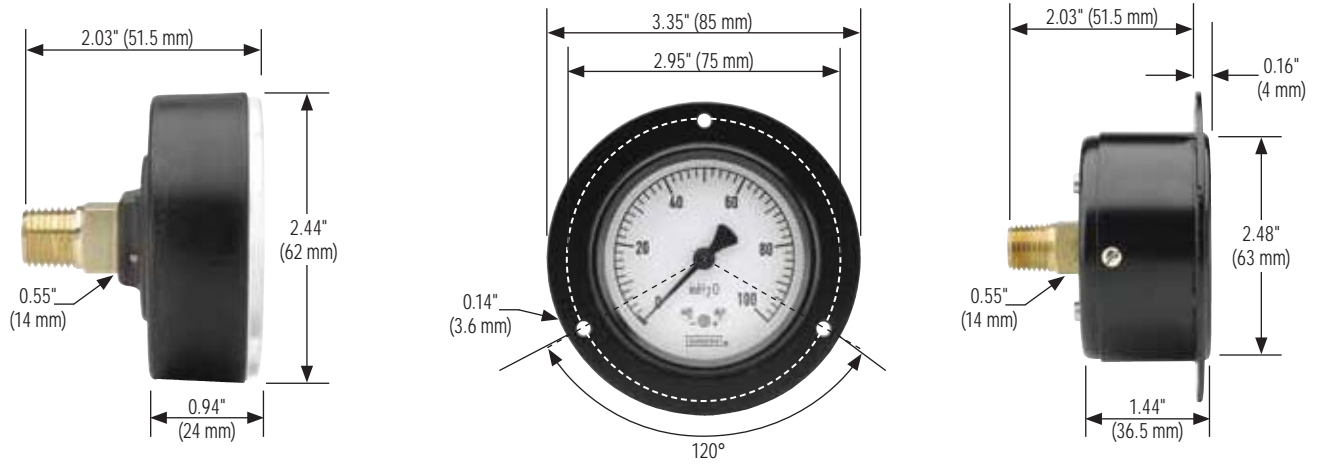

25-200 Rear Flange

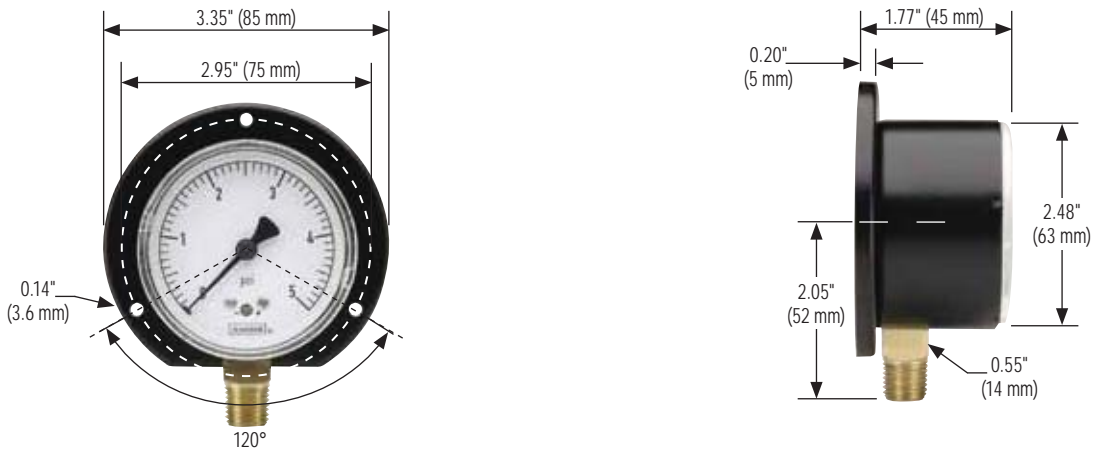

40-200 Rear Flange

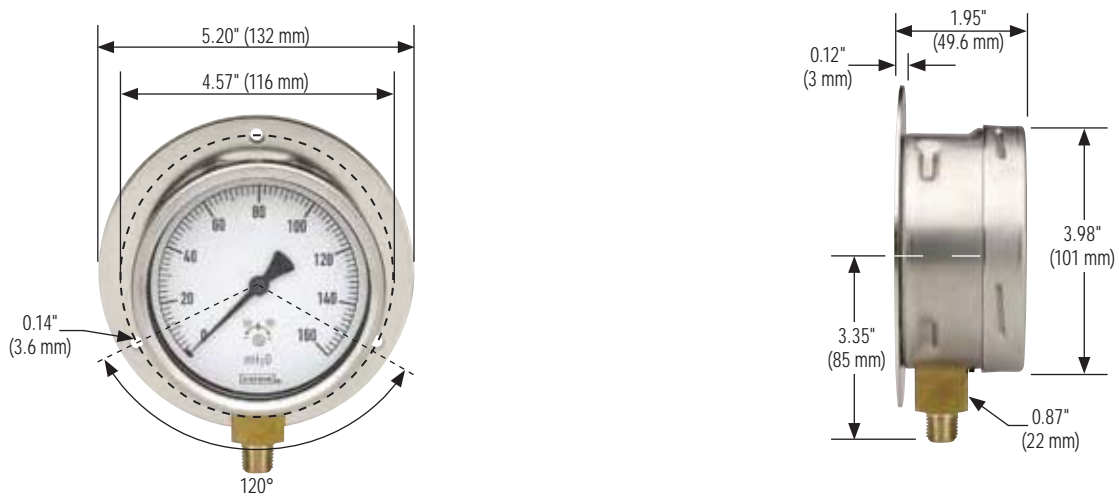

25-210 Triangular Bezel w/U-Clamp

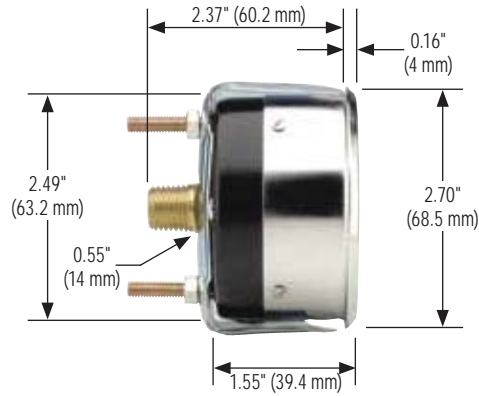

25-224 with Panel Mount Clamp

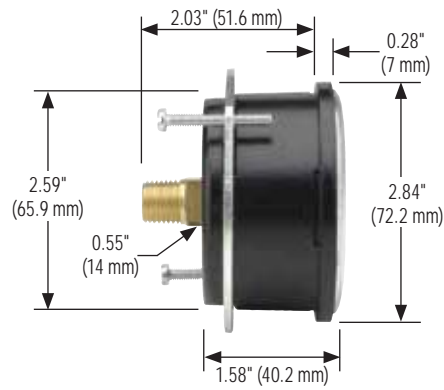

25-234

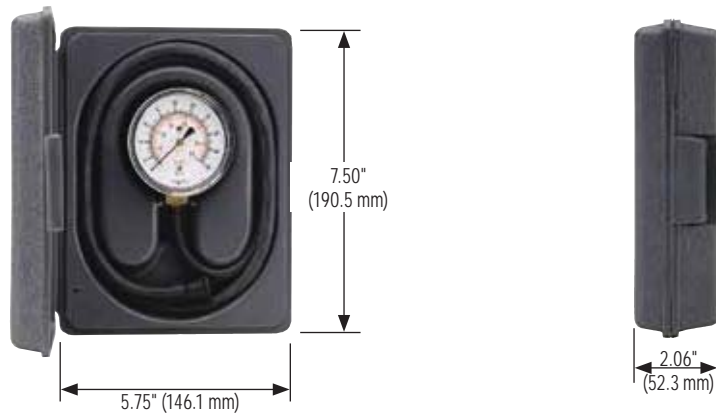

Brass Case, Liquid Filled



300 SERIES

- High quality, heavy-duty liquid filled gauge
- Vacuum and compound ranges through 0 psi to 15,000 psi
- 2-1/2" and 4" gauge sizes
- Die cast brass case with natural brass finish
- Copper alloy or 316 stainless steel and brass wetted parts

OPERATING SPECIFICATIONS

1. Working Pressure Limitations

a. Dynamic Pressure

The working pressure should be limited to 60% of the dial range.

b. Static Pressure

The working pressure, where no sharp fluctuations occur, should be limited to 90% of the dial range.

APPLICATIONS

- Automotive
- Construction
- Hydraulics & pneumatics
- Mining
- Stamping & forming presses
- Transportation

	SERIES	SPECIFICATIONS
Pressure ranges	300 Series (all)	Vacuum and compound ranges through 0 psi to 15,000 psi
Accuracy	25-300, 25-310	±1.6% full scale
	40-300, 40-310	± 1% full scale
Temperature ranges*	300 Series (all)	Media -4 °F to 140 °F (-20 °C to 60 °C) Ambient 0 °F to 160 °F (-18 °C to 71 °C) Optional temperature ratings available from -40 °F to 212 °F (-40 °C to 100 °C)
Measuring element	25-300, 25-310 (≤ 600 psi)	Copper alloy °C tube
	25-300, 25-310 (800 psi to 6,000 psi)	Copper alloy coiled safety tube
	25-300, 25-310 (7,500 psi to 15,000 psi)	316 stainless steel coiled safety tube
	40-300, 40-310 (≤ 1,000 psi)	Copper alloy °C tube
	40-300, 40-310 (15,000 psi)	316 stainless steel coiled safety tube
Connection	25-300, 25-310	1/4" NPT die-cast brass with the case. 7/16" – 20 SAE adjustable type straight thread with FKM O-ring is also available as a stock option on many ranges (-4 SAE).
	40-300, 40-310	1/4" NPT die-cast brass with the case. 1/2" NPT is available on certain 40-300 ranges as a stock option, and on all other 40-300 and 40-310's as a non-stock option.
Case	300 Series (all)	Die cast brass (natural brass finish) with safety relief plug
Cover ring	300 Series (all)	Polished brass
Lens	300 Series (all)	Acrylic with o-ring seal
Pointer	300 Series (all)	Balanced aluminum, black finish
Dial	300 Series (all)	Aluminum, white background with black scale. UV resistant.
Movement	300 Series (all)	Brass and nickel-silver with highly polished bearing surfaces
Fill liquid**	300 Series (all)	Glycerin

For details on accuracy/standard dial configuration and dial layouts, see pages 54-59.

* For every 18 °F (10 °C) shift in temperature from which the gauge is calibrated, the user can experience up to ±0.4% additional error.

** See page 53 for gauge fill options.

ORDERING INFORMATION								
GAUGE SIZES	25 2-1/2"		40 4"					
CASE TYPES	300 Brass, bottom connection		310 Brass, back connection					
PRESSURE RANGES	30vac	-30 inHg to 0 psi	30/300	-30 inHg to 0 to 300 psi	300	0 psi to 300 psi	3000	0 psi to 3,000 psi
	30/15	-30 inHg to 0 to 15 psi	15	0 psi to 15 psi	400	0 psi to 400 psi	5000	0 psi to 5,000 psi
	30/30	-30 inHg to 0 to 30 psi	30	0 psi to 30 psi	600	0 psi to 600 psi	6000	0 psi to 6,000 psi
	30/60	-30 inHg to 0 to 60 psi	60	0 psi to 60 psi	800	0 psi to 800 psi	7500	0 psi to 7,500 psi
	30/100	-30 inHg to 0 to 100 psi	100	0 psi to 100 psi	1000	0 psi to 1,000 psi	10000	0 psi to 10,000 psi
	30/160	-30 inHg to 0 to 160 psi	160	0 psi to 160 psi	1500	0 psi to 1,500 psi	15000	0 psi to 15,000 psi
	30/200	-30 inHg to 0 to 200 psi	200	0 psi to 200 psi	2000	0 psi to 2,000 psi		
SCALE OPTIONS	psi	psi single scale	psi/kPa	psi/kPa dual scale	psi/kg/cm ²	psi/kg/cm ² dual scale	psi/bar	psi/bar dual scale
CONNECTION SIZES	1/4	1/4" NPT	1/2	1/2" NPT	SST	SAE J1926-3:7/16-20 Adjustable		
OPTIONS	CFF	Chrome Front Flange	RF	Rear Flange	GLO	Glass Lens Overlay	ST	Stainless Steel Tagging
	CFFN	Chrome Front Flange w/o holes	CCR	Chrome Cover Ring	SGO	Safety Glass Overlay	BT3	Brass Threaded Orifice 0.3 mm
	BFF	Brass Front Flange	CBU	Chrome Bezel & U-Clamp	AR	Adapter Ring	BT4	Brass Threaded Orifice 0.4 mm
	BLFF	Black Front Flange	MIP	Maximum Indicating Pointer	LM	Laser Marking	BT8	Brass Threaded Orifice 0.8 mm
	SSRF	304SS Rear Flange	LL	Polycarbonate Lens				

Please consult your local NOSHOK Distributor or NOSHOK, Inc. for availability and delivery information.

NOTE: Refer to 300 Series Options & Accessories chart on page 51 for availability by part number.

EXAMPLE

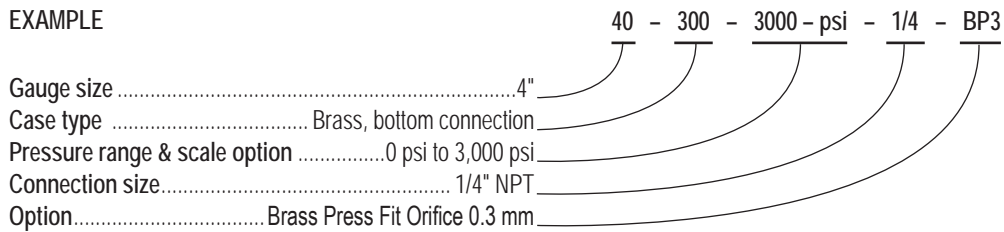

25-300

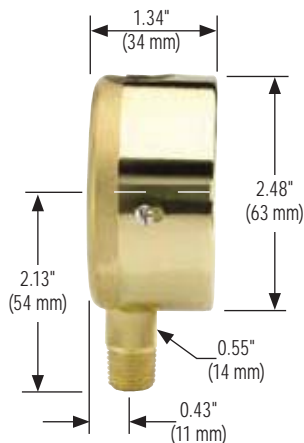

40-300

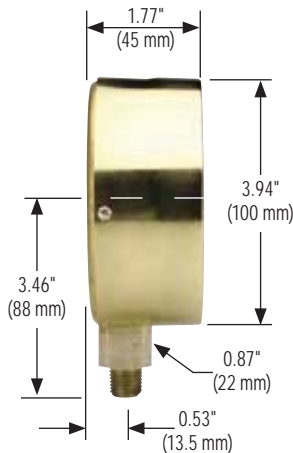

25-310

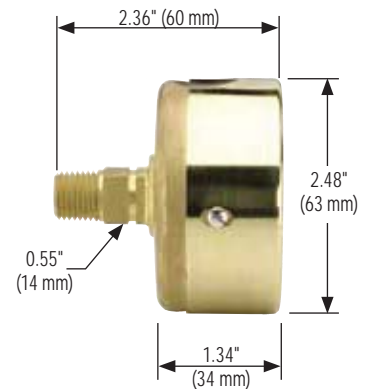

Dimensions

40-310

25-300 Front Flange

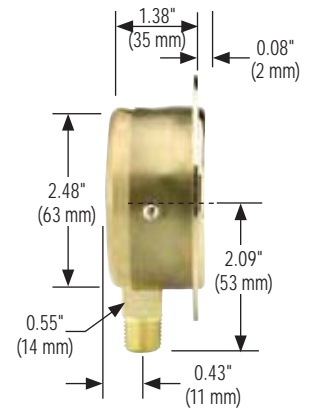
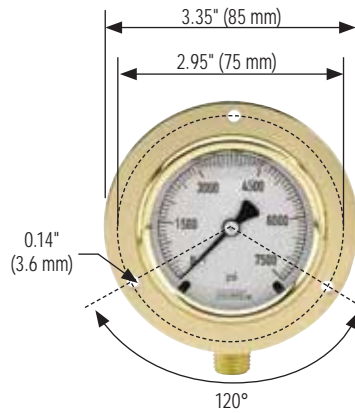
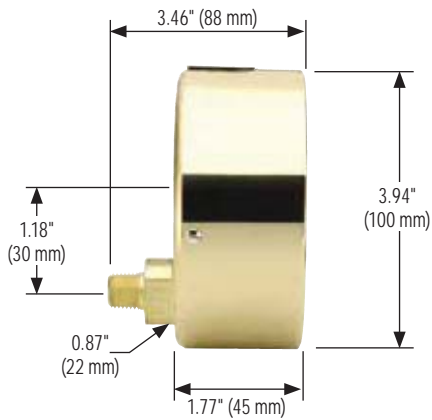

40-300 Front Flange

25-310 Front Flange

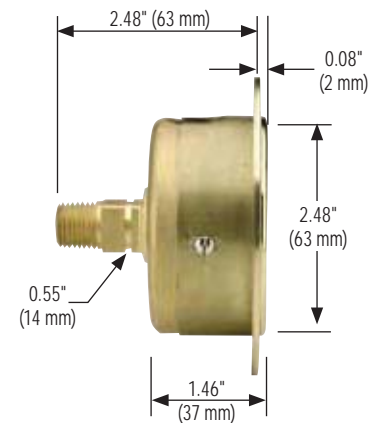
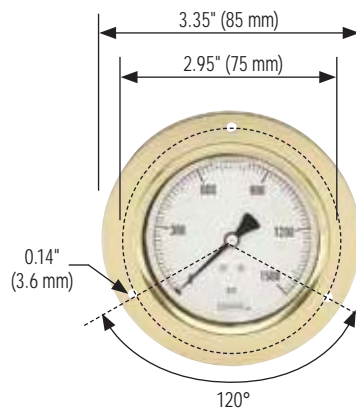
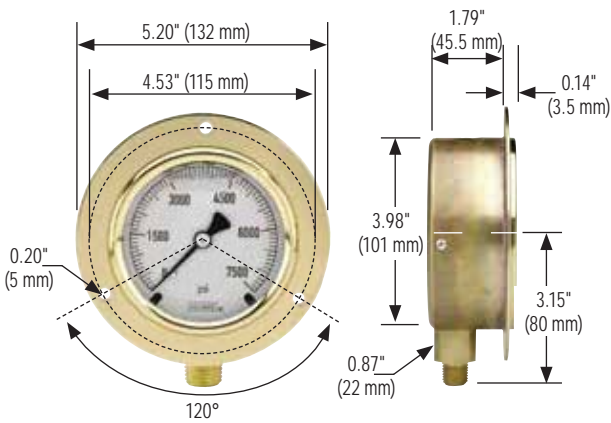

40-310 Front Flange

25-300 Rear Flange

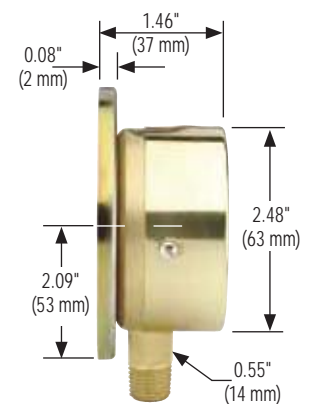
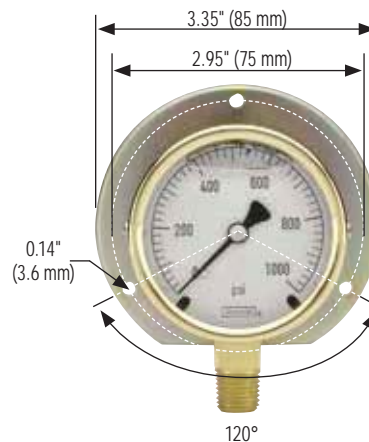
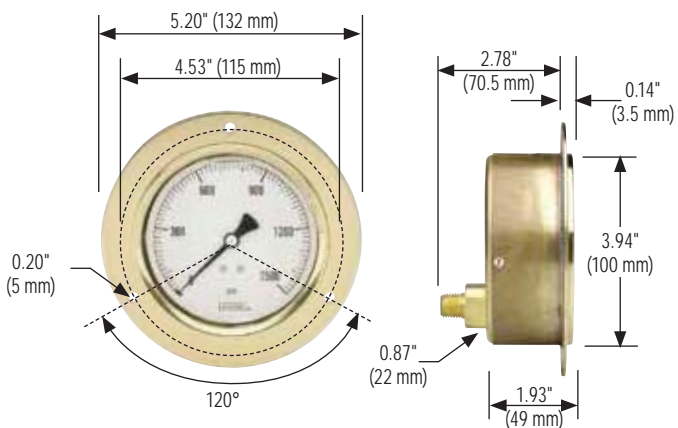

40-300 Rear Flange

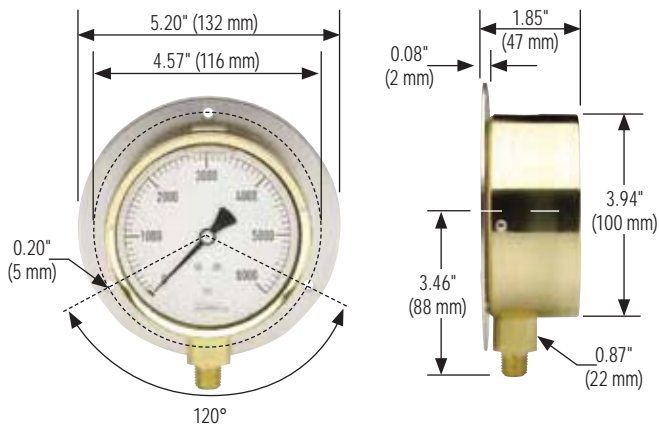

25-310 Rear Flange

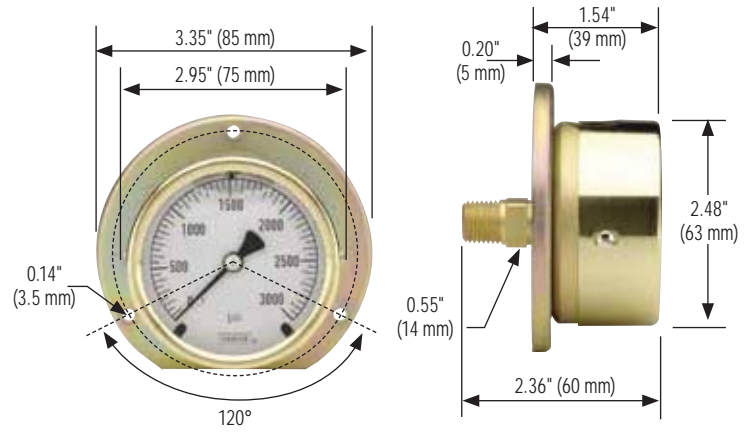

40-310 Rear Flange

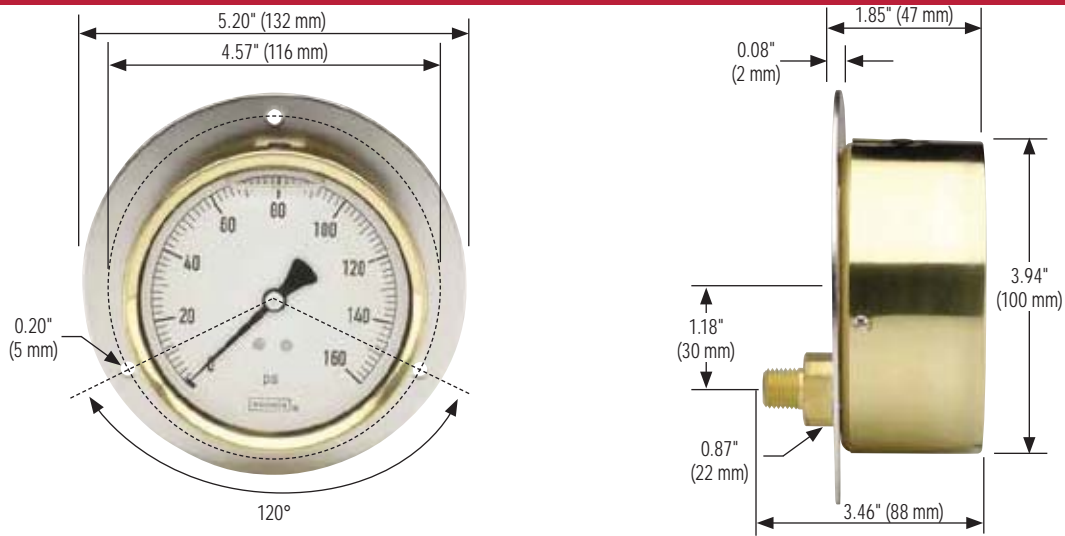

25-310 Chrome Triangular Bezel with U-Clamp

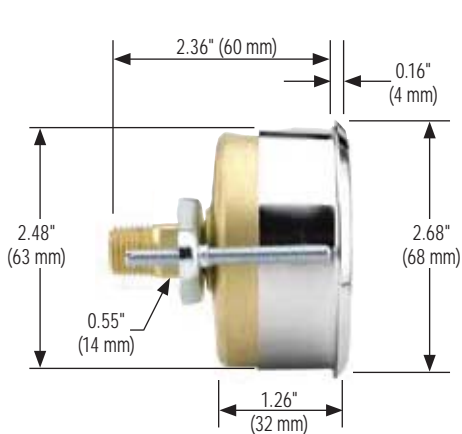

40-310 Chrome Triangular Bezel with U-Clamp

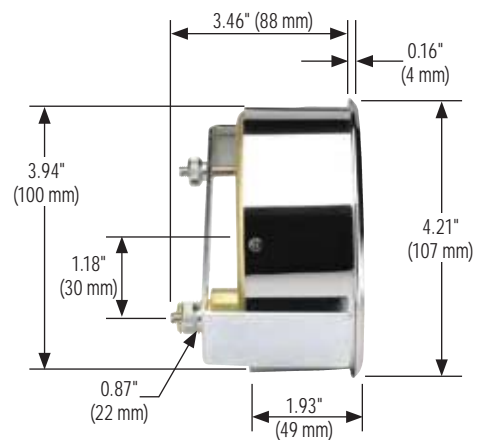

All Stainless Steel, Dry & Liquid Filled



400/500 SERIES

- Corrosion-resistant fillable dry or liquid-filled gauge
- Vacuum and compound ranges through 0 psi to 100,000 psi
- 1-1/2", 2-1/2", 4 and 6" gauge sizes
- Stainless steel case
- 316 stainless steel wetted parts
- ECE-R110 Certification for CNG/LNG Pressure Gauge Component (Part number 25-410-300-psi/bar only)

OPERATING SPECIFICATIONS

1. Working Pressure Limitations

a. Dynamic Pressure

The working pressure should be limited to 60% of the dial range.

b. Static Pressure

The working pressure, where no sharp fluctuations occur, should be limited to 90% of the dial range

APPLICATIONS

- Chemical processing
- Oil field & offshore
- Paper mills
- Agriculture plants
- Marine
- Water & wastewater

* For every 18 °F (10 °C) shift in temperature from which the gauge is calibrated, the user can experience up to ±0.4% additional error.

** See page 53 for gauge fill options.

For details on accuracy/standard dial configuration and dial layouts, see pages 54-59.

	SERIES	SPECIFICATIONS
Pressure ranges	400/500 Series (all)	Vacuum and compound ranges through 0 psi to 100,000 psi
Accuracy	15-401, 15-411	±2.5% full scale
	25-400, 25-410, 25-500, 25-510	±1.6% full scale
	40-400, 40-410, 40-500, 40-510, 60-400, 60-410, 60-500, 60-510	±1% full scale
Temperature ranges*	15-401, 15-411, 25-400, 25-410	Media -40 °F to 212 °F (-40 °C to 100 °C) Ambient -40 °F to 140 °F (-40 °C to 60 °C)
	40-400, 40-410, 60-400, 60-410	Media -40 °F to 392 °F (-40 °C to 200 °C) Ambient -40 °F to 140 °F (-40 °C to 60 °C)
	500 Series (all)	Media -4 °F to 212 °F (-20 °C to 100 °C) Glycerin fill -40 °F to 212 °F (-40 °C to 100 °C) Special fill Ambient -4 °F to 140 °F (-20 °C to 60 °C) Glycerin fill -40 °F to 140 °F (-40 °C to 60 °C) Special fill
Measuring element	15-401, 15-411, 25-400, 25-410, 25-500, 25-510, 40-400, 40-410, 40-500, 40-510, 60-400, 60-410, 60-500, 60-510 (up to 600 psi)	316 stainless steel C-Type Bourdon tube
	25-400, 25-410, 25-500, 25-510, 40-400, 40-410, 40-500, 40-510, 60-400, 60-410, 60-500, 60-510 (greater than 600 psi)	Coiled safety tube
Connection	15-401, 15-411	1/8" NPT, 316 stainless steel
	25-400, 25-410, 25-500, 25-510	1/4" NPT, 316 stainless steel
	40-400, 40-410, 40-500, 40-510, 60-400, 60-410, 60-500, 60-510	1/2" NPT, 316 stainless steel. 9/16" – 18 high pressure connections are standard on 0 - 30,000 psi and higher
Case	15-401, 15-411, 40-400, 40-410, 60-400, 60-410, 60-500, 60-510	304 stainless steel (Optional 316 stainless steel) with safety relief plug
	25-400, 25-410, 25-500, 25-510, 40-500, 40-510	Polished 304 stainless steel with safety relief plug
Cover ring	15-401, 15-411, 25-400, 25-410, 25-500, 25-510, 40-400, 40-410, 40-500, 40-510	Polished 304 stainless steel
	60-400, 60-410, 60-500, 60-510	Polished 304 stainless steel bayonet ring
Lens	15-401, 15-411, 40-400, 40-410, 40-500, 40-510	Instrument glass
	25-400, 25-410, 25-500, 25-510	Trogamide
	60-400, 60-410, 60-500, 60-510	Laminated safety glass
Pointer	115-401, 15-411	Black finished aluminum
	25-400, 25-410, 25-500, 25-510, 40-400, 40-410, 40-500, 40-510	Balanced aluminum, black finish
	60-400, 60-410, 60-500, 60-510	Balanced micro-adjustable aluminum, black finish
Dial	15-401, 15-411	Aluminum, white background with black scale. Single scale psi. UV resistant
	25-400, 25-410, 25-500, 25-510, 40-400, 40-410, 40-500, 40-510, 60-400, 60-410, 60-500, 60-510	Aluminum, white background with black scale. UV resistant.
Movement	15-401, 15-411, 25-400, 25-410, 25-500, 25-510	Stainless steel with highly polished bearing surfaces
	40-400, 40-410, 40-500, 40-510	All stainless steel with internal zero stop and highly polished bearing surfaces
	60-400, 60-410, 60-500, 60-510	Stainless steel with highly polished bearing surfaces. An internal zero stop is standard
Fill liquid**	25-500, 25-510, 40-500, 40-510, 60-500, 60-510	Glycerin

ORDERING INFORMATION				
GAUGE SIZES	15 1-1/2"	25 2-1/2"	40 *** 4"	60 *** 6"
CASE TYPES	400 All SS, dry/fillable, bottom connection 401 All SS, dry, bottom connection 402 SS case, solid front, dry, bottom connection**	410 All SS, dry/fillable, back connection 411 All SS, dry, back connection 500 SS case, liquid filled, bottom connection	502 SS case, solid front, liquid filled, bottom connection** 510 SS case, liquid filled, back connection	
PRESSURE RANGES	30vac† -30 inHg to 0 psi 30/15† -30 inHg to 0 psi to 15 psi 30/30† -30 inHg to 0 psi to 30 psi 30/60† -30 inHg to 0 psi to 60 psi 30/100† -30 inHg to 0 psi to 100 psi 30/160† -30 inHg to 0 psi to 160 psi 30/200† -30 inHg to 0 psi to 200 psi 30/300† -30 inHg to 0 psi to 300 psi 15 0 psi to 15 psi 30 0 psi to 30 psi 60 0 psi to 60 psi	100 0 psi to 100 psi 160 0 psi to 160 psi 200 0 psi to 200 psi 300 0 psi to 300 psi 400 0 psi to 400 psi 600 0 psi to 600 psi 800 0 psi to 800 psi 1000 0 psi to 1,000 psi 1500 0 psi to 1,500 psi 2000 0 psi to 2,000 psi 3000 0 psi to 3,000 psi	5000 0 psi to 5,000 psi 6000 0 psi to 6,000 psi 10000 0 psi to 10,000 psi 15000 0 psi to 15,000 psi 20000 0 psi to 20,000 psi 30000 0 psi to 30,000 psi 40000 0 psi to 40,000 psi 60000 0 psi to 60,000 psi 80000 0 psi to 80,000 psi 100000 0 psi to 100,000 psi	
SCALE OPTIONS	psi psi single scale psi/kPa psi/kPa dual scale	psi/kg/cm ² psi/kg/cm ² dual scale psi/bar psi/bar dual scale		
CONNECTION SIZES	1/8 1/8" NPT 1/4 1/4" NPT	1/2 1/2" NPT 9/16-18 9/16"-18 UNF 2B high pressure cone*		SST SAE J1926-3/7/16-20 Adjustable
OPTIONS	SSFF 304SS Front Flange SSRF 304SS Rear Flange SSBU Stainless Steel Bezel & U-Clamp SPMC 304SS Panel Mount Clamp PMC Steel Panel Mount Clamp	SSFR 304SS Flange Ring FR Flange Ring AP Adjustable Pointer SG Safety Glass Lens MIP Maximum Indicating Pointer	SP Red Set Pointer LM Laser Marking ST Stainless Steel Tagging ST5 Stainless Steel Threaded Orifice 0.5 mm ST8 Stainless Steel Threaded Orifice 0.8 mm	

Please consult your local NOSHOK Distributor or NOSHOK, Inc. for availability and delivery information.

NOTE: Refer to 400/500 Series options & Accessories chart on page 52 for availability by part number.

* Connection size for pressures 30,000 psi and above. Equivalent to F250C Parker Autoclave.

** 6" solid front, safety case and blowout back is standard for pressures 80,000 psi and above.

*** On 40-400, 40-410, 40-500, 40-510, 60-400, 60-410, 60-500, and 60-510 models with pressure ranges between 20,000 and 60,000 psi, the accuracy is ±1.5% or 1.6%.

† Ammonia gauges are available in these ranges. To order, add " - AMMONIA" at the end of the part number.

EXAMPLE

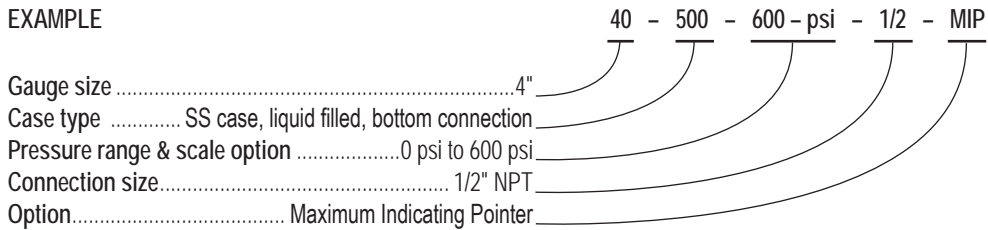

15-401

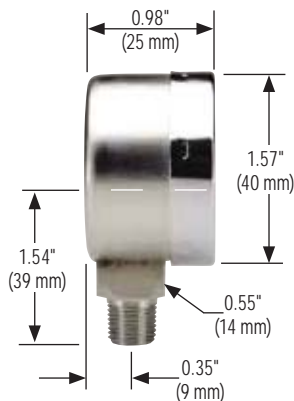

25-400/500



40-400/500

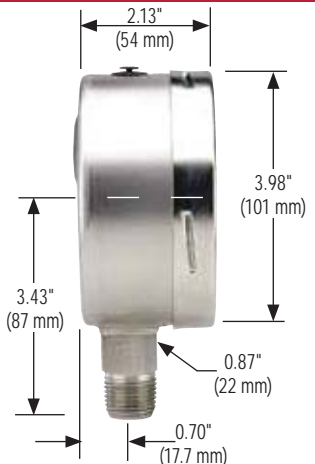

Dimensions

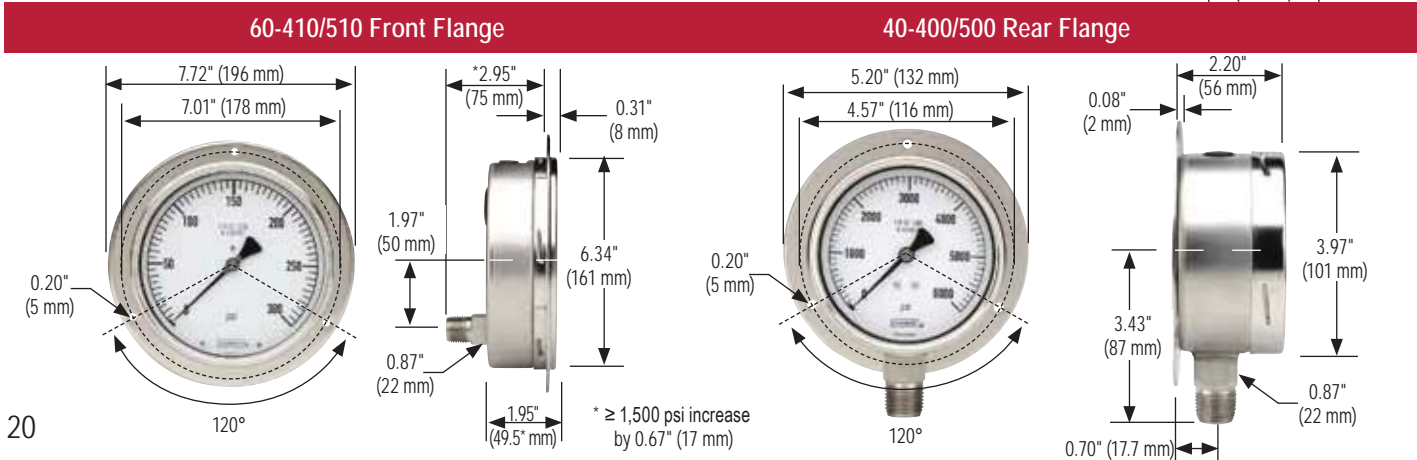
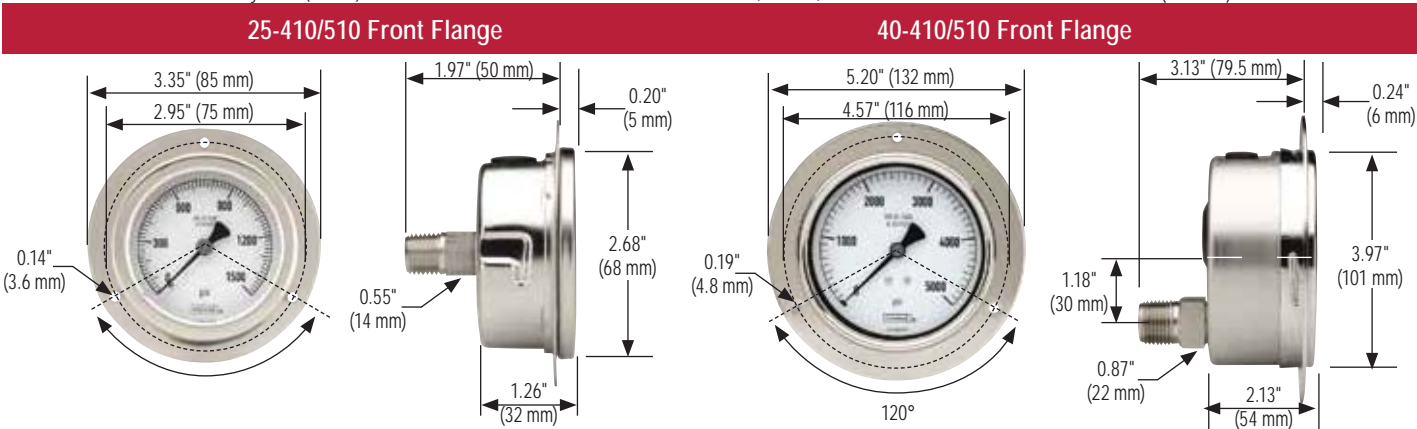
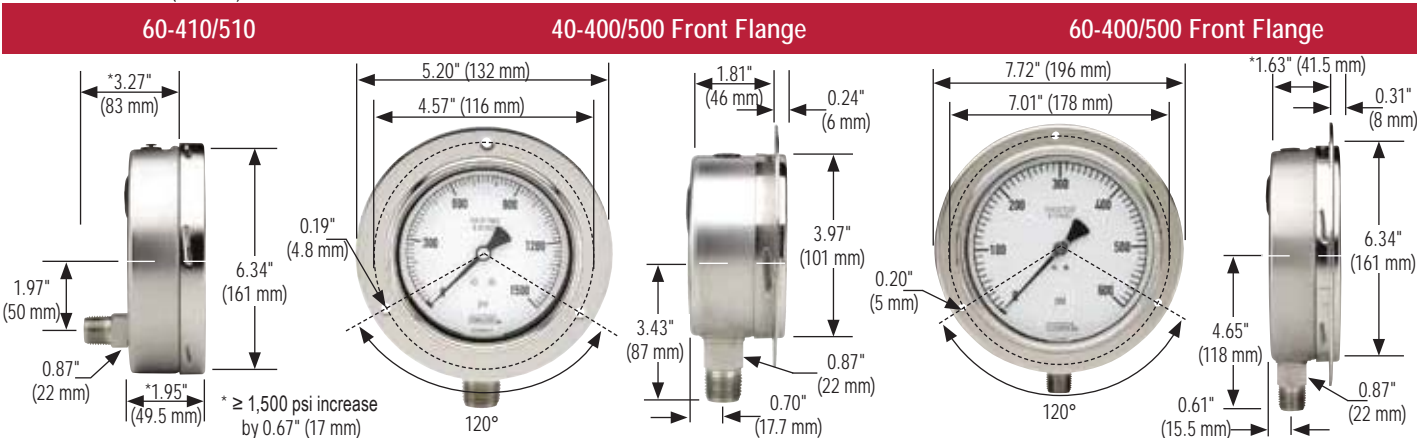
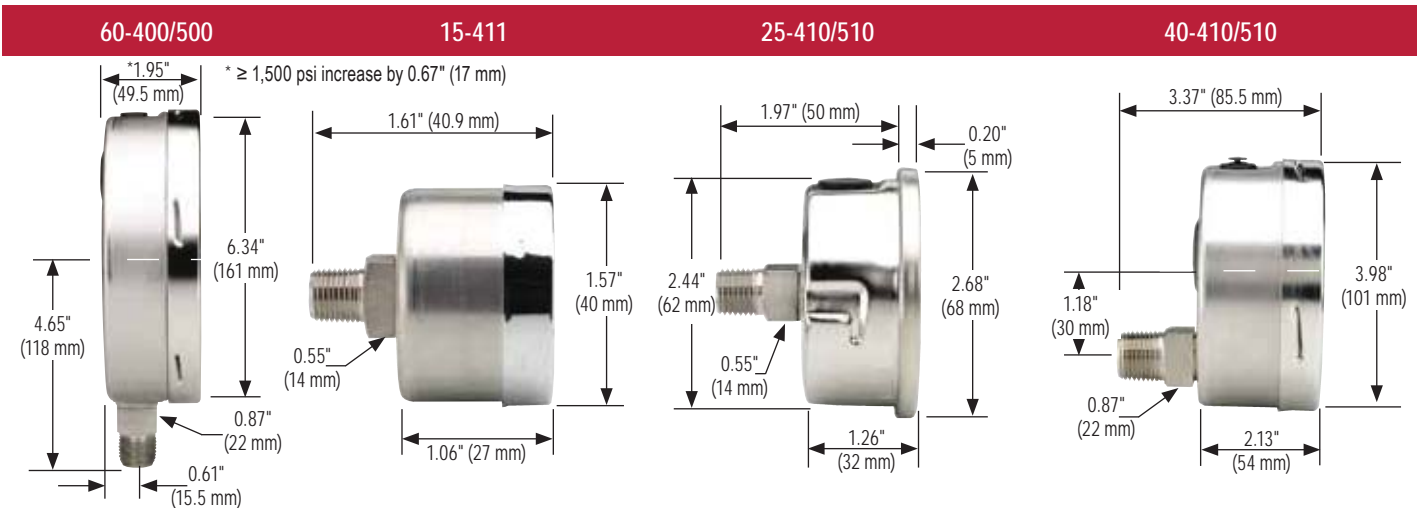

60-400/500 Rear Flange

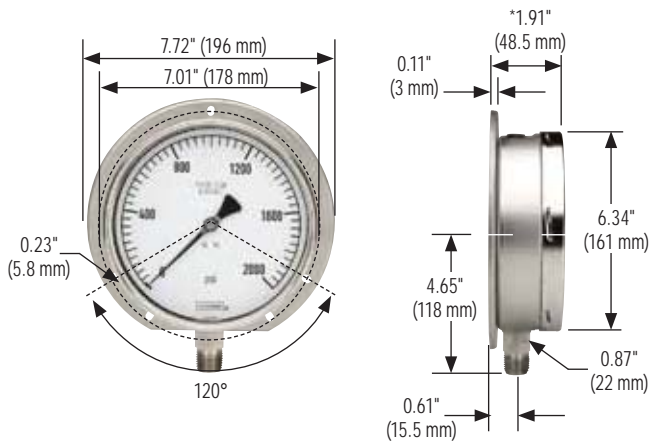

40-410/510 Rear Flange

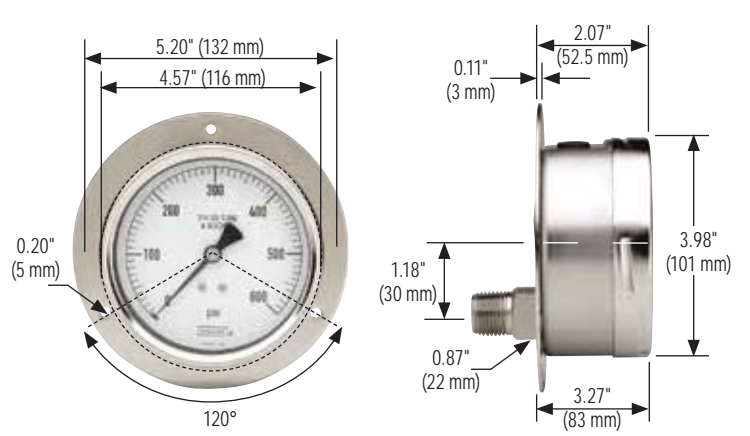

60-410/510 Rear Flange

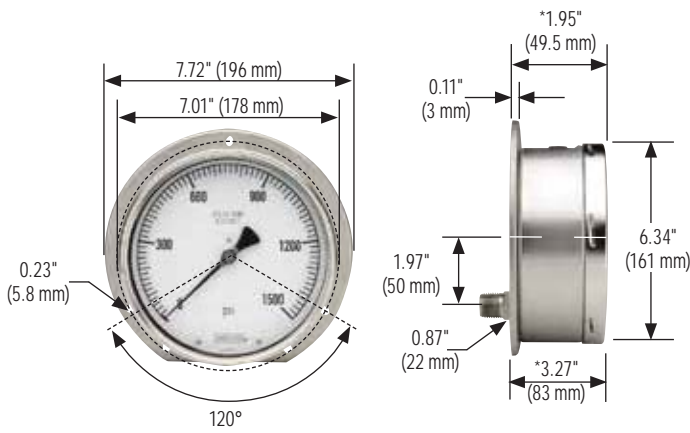

25-410/510 Flange Ring

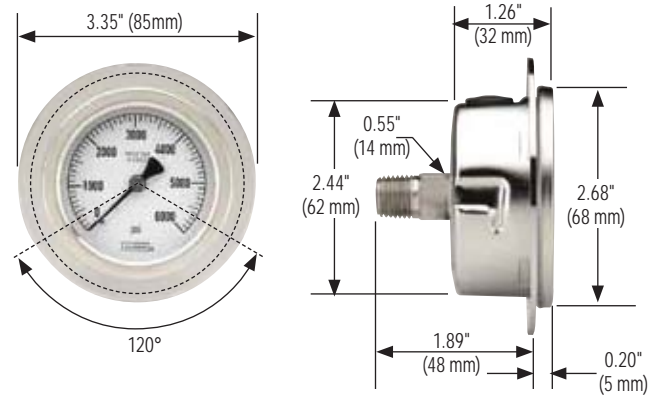

25-410/510 Panel Mount Clamp

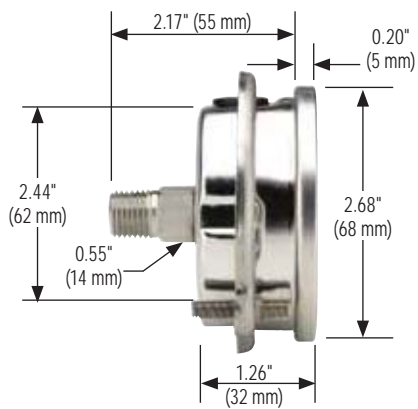

40-410/510 SS Narrow Bezel w/U-Clamp

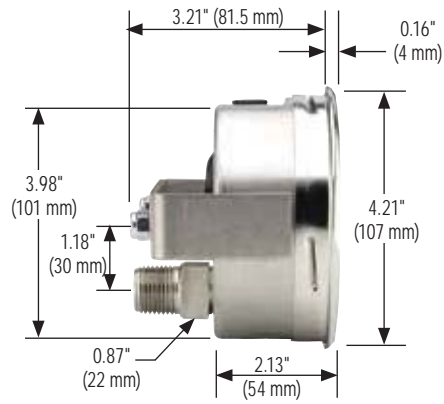

60-410/510 SS Narrow Bezel w/U-Clamp

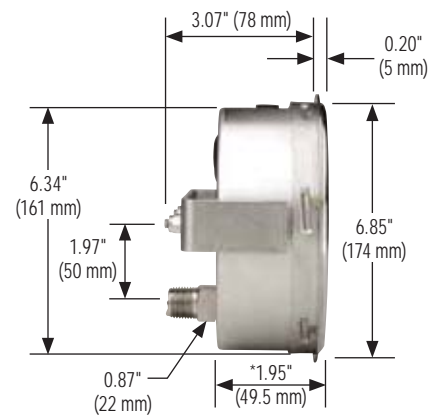

* Dimension will be 0.67" (17 mm) for pressure ranges above 1,500 psi.

Process



600/700 SERIES

- Turret style dry or liquid-filled gauge
- Vacuum and compound ranges through 0 psi to 60,000 psi
- 4-1/2" gauge sizes
- Black phenolic safety case with solid front and blow-out back PBT
- Phosphor bronze, 316 stainless steel and brass wetted parts

OPERATING SPECIFICATIONS

1. Working Pressure Limitations

a. Dynamic Pressure

The working pressure should be limited to 60% of the dial range.

b. Static Pressure

The working pressure, where no sharp fluctuations occur, should be limited to 90% of the dial range

APPLICATIONS

- Injection molding machines
- Laboratory & test equipment
- Power generation
- Oil field & offshore
- Utilities
- Water & wastewater

* For every 18 °F (10 °C) shift in temperature from which the gauge is calibrated, the user can experience up to ±0.4% additional error.

** See page 53 for gauge fill options.

	SERIES	SPECIFICATIONS
Pressure ranges	600/700 Series (all)	Vacuum and compound ranges through 0 psi to 60,000 psi
Accuracy	45-640, 45-660	±0.5% full scale
	45-740, 45-760	±0.5% full scale ±1.6% full scale for inH ₂ O, 5 psi and 10 psi ±1% full scale for ≥20,000 psi
Temperature ranges*	45-640	Media -4 °F to 150 °F (-20 °C to 65 °C) Ambient -40 °F to 150 °F (-40 °C to 65 °C)
	45-740	Media -40 °F to 212 °F (-40 °C to 100 °C) 500 °F (260 °C) Maximum for short term/intermittent Ambient -40 °F to 150 °F (-40 °C to 65 °C)
	45-660	Media -4 °F to 150 °F (-20 °C to 65 °C) Glycerin fill -40 °F to 150 °F (-40 °C to 65 °C) Special fill Ambient -4 °F to 150 °F (-20 °C to 65 °C) Glycerin fill -40 °F to 150 °F (-40 °C to 65 °C) Special fill
	45-760	Media -4 °F to 212 °F (-20 °C to 100 °C) Glycerin fill -40 °F to 212 °F (-40 °C to 100 °C) Special fill 250 °F (130 °C) Maximum for short term/intermittent Ambient -4 °F to 150 °F (-20 °C to 65 °C) Glycerin fill -40 °F to 150 °F (-40 °C to 65 °C) Special fill
Case	600/700 Series (all)	Turret style black phenolic case. Solid front, safety case with blow-out back PBT.
Bayonet ring	600/700 Series (all)	Threaded black PBT
Lens	600/700 Series (all)	Acrylic
Measuring Element	45-640, 45-660 (≤ 600 psi)	Copper alloy C-Type Bourdon tube
	45-740, 45-760 (≤ 600 psi)	316 stainless steel C-Type Bourdon tube
	600/700 Series (all) (>600 psi)	316 stainless steel coiled safety Bourdon tube
	45-740 (≤ 10 psi)	316 stainless steel capsule
Connection	45-640, 45-660	1/4" NPT, brass
	45-740, 45-760	1/4" NPT or 1/2" NPT, 316 stainless steel
Movement	45-640, 45-660	Brass and nickel-silver with highly polished bearing surfaces. An internal zero stop is standard.
	45-740, 45-760	Stainless steel with highly polished bearing surfaces. An internal zero stop is standard.
Pointer	600/700 Series (all)	Balanced micro-adjustable aluminum, black finish
Dial	600/700 Series (all)	Aluminum, white background with black scale. UV resistant.
Fill liquid **	45-660, 45-760	Glycerin

For details on accuracy/standard dial configuration and dial layouts, see pages 54-59.

ORDERING INFORMATION								
GAUGE SIZES		45 4-1/2"						
CASE TYPES		640 Brass, dry, bottom connection	660 Brass, liquid filled, bottom connection					
		740 SS, dry, bottom connection	760 SS, liquid filled, bottom connection					
PRESSURE RANGES	30 inH ₂ O vac	-30 inH ₂ O to 0 inH ₂ O	30/30	-30 inHg to 0 to 30 psi	60	0 psi to 60 psi	2000	0 psi to 2,000 psi
	60 inH ₂ O vac	-60 inH ₂ O to 0 inH ₂ O	30/60	-30 inHg to 0 to 60 psi	100	0 psi to 100 psi	3000	0 psi to 3,000 psi
	60/60 inH ₂ O	-60 inH ₂ O to 60 inH ₂ O	30/100	-30 inHg to 0 to 100 psi	160	0 psi to 160 psi	5000	0 psi to 5,000 psi
	60 inH ₂ O	0 inH ₂ O to 60 inH ₂ O	30/160	-30 inHg to 0 to 160 psi	200	0 psi to 200 psi	6000	0 psi to 6,000 psi
	100 inH ₂ O	0 inH ₂ O to 100 inH ₂ O	30/200	-30 inHg to 0 to 200 psi	300	0 psi to 300 psi	10000	0 psi to 10,000 psi
	160 inH ₂ O	0 inH ₂ O to 160 inH ₂ O	30/300	-30 inHg to 0 to 300 psi	400	0 psi to 400 psi	15000	0 psi to 15,000 psi
	200 inH ₂ O	0 inH ₂ O to 200 inH ₂ O	5	0 psi to 5 psi	600	0 psi to 600 psi	20000	0 psi to 20,000 psi
	300 inH ₂ O	0 inH ₂ O to 300 inH ₂ O	10	0 psi to 10 psi	800	0 psi to 800 psi	30000	0 psi to 30,000 psi
	30vac	-30 inHg to 0 psi	15	0 psi to 15 psi	1000	0 psi to 1,000 psi	40000	0 psi to 40,000 psi
	30/15	-30 inHg to 0 to 15 psi	30	0 psi to 30 psi	1500	0 psi to 1,500 psi	60000	0 psi to 60,000 psi
SCALE OPTIONS		inH ₂ O inH ₂ O single scale	psi psi single scale	psi/kg/cm ² psi/kg/cm ² dual scale	psi/bar psi/bar dual scale			
CONNECTION SIZES		1/4 1/4" NPT	1/2 1/2" NPT	9/16-18 9/16-18 UNF 3B (above 30,000 psi standard)				
OPTIONS		SG Safety Glass Lens	CPMR Uninstalled Chrome Panel Mount Ring	BP3 Brass Press Fit Orifice 0.3 mm				
		GL Glass Lens	OS Overload Stop	BT3 Brass Threaded Orifice 0.3 mm				
		MIP Maximum Indicating Pointer	LM Laser Marking	ST8 316SS Threaded Orifice 0.8 mm				
		BPMR Uninstalled Black Panel Mount Ring	ST Stainless Steel Tagging					

Please consult your local NOSHOK Distributor or NOSHOK, Inc. for availability and delivery information.

NOTE: Refer to 600/700 Series Options & Accessories chart on page 52 for availability by part number.

EXAMPLE

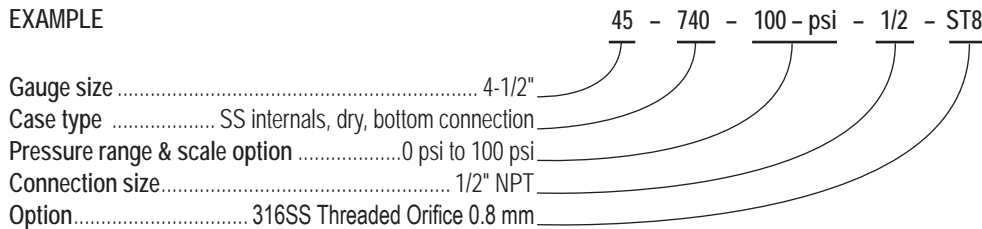

45-640/660 & 45-740/760

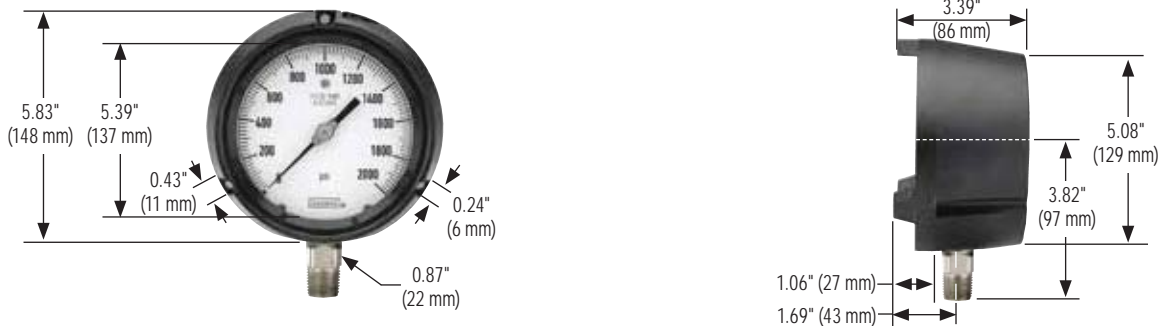

45-640/660 & 45-740/760 Panel Mount Ring

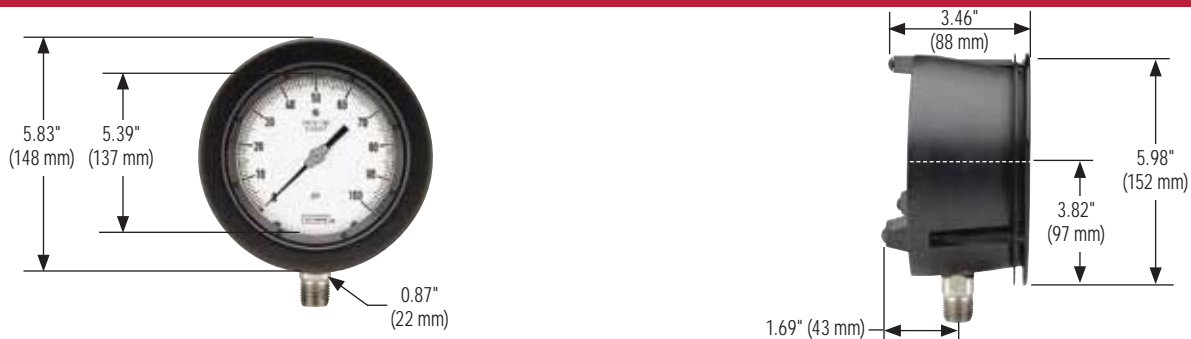

Precision Test



800 SERIES

- Highly accurate dry gauge
- Vacuum and compound ranges through 0 psi to 6,000 psi
- 6" gauge size
- Stainless steel case
- Beryllium copper, 316 stainless steel, and brass wetted parts

OPERATING SPECIFICATIONS

1. Working Pressure Limitations

a. Static Pressure

The working pressure, where no sharp fluctuations occur, should be limited to 100% of the dial range.

NOTE: 800 Series Precision Test gauges are not intended for dynamic applications.

APPLICATIONS

- Aerospace equipment
- Gauge repair facilities
- Laboratory & test equipment
- Precision measurement

	SERIES	SPECIFICATIONS
Pressure ranges	60-800	Vacuum and compound ranges through 0 psi to 6,000 psi
Accuracy	60-800	±0.25% full scale
Temperature ranges*	60-800	Media -40 °F to 180 °F (-40 °C to 80 °C) Ambient -40 °F to 140 °F (-40 °C to 60 °C)
Measuring element	60-800	Beryllium copper Bourdon tube to 1,000 psi 316 SS Bourdon tube 1,500 psi to 6,000 psi
Connection	60-800	1/4" NPT bottom connection, brass
Case	60-800	304 stainless steel
Cover ring	60-800	304 stainless steel
Lens	60-800	Instrument glass
Pointer	60-800	Adjustable knife-edge pointer
Dial	60-800	Aluminum, white mirrored background with black scale.
Movement	60-800	Brass with jeweled bearings nickel-silver pinion gear and shafts

* For every 18 °F (10 °C) shift in temperature from which the gauge is calibrated, the user can experience up to ±0.4% additional error.

For details on accuracy/standard dial configuration and dial layouts, see pages 54-59.

ORDERING INFORMATION									
GAUGE SIZE	60 6"								
CASE TYPE	800 SS Case, bottom connection								
PRESSURE RANGES	30vac	-30 inHg to 0 psi	30/300	-30 inHg to 0 to 300 psi	300	0 psi to 300 psi	5000	0 psi to 5,000 psi	
	30/15	-30 inHg to 0 to 15 psi	15	0 psi to 15 psi	400	0 psi to 400 psi	6000	0 psi to 6,000 psi	
	30/30	-30 inHg to 0 to 30 psi	30	0 psi to 30 psi	600	0 psi to 600 psi			
	30/60	-30 inHg to 0 to 60 psi	60	0 psi to 60 psi	1000	0 psi to 1,000 psi			
	30/100	-30 inHg to 0 to 100 psi	100	0 psi to 100 psi	1500	0 psi to 1,500 psi			
	30/160	-30 inHg to 0 to 160 psi	160	0 psi to 160 psi	2000	0 psi to 2,000 psi			
	30/200	-30 inHg to 0 to 200 psi	200	0 psi to 200 psi	3000	0 psi to 3,000 psi			
SCALE OPTION	psi psi single scale								
CONNECTION SIZES	1/4	1/4" NPT	1/2	1/2" NPT	SST	SAE J1926-3: 7/16-20 Adjustable			
OPTIONS	SSFF	304SS Front Flange		ST	Stainless Steel Tagging				
	SSRF	304SS Rear Flange		BP3	Brass Press Fit Orifice 0.3 mm				
	GC	Gauge Carrying Case				BT8	Brass Threaded Orifice 0.8 mm		
	LM	Laser Marking							

Please consult your local NOSHOK Distributor or NOSHOK, Inc. for availability and delivery information.

NOTE: Refer to 800 Series Options & Accessories chart on page 52 for availability by part number.

EXAMPLE

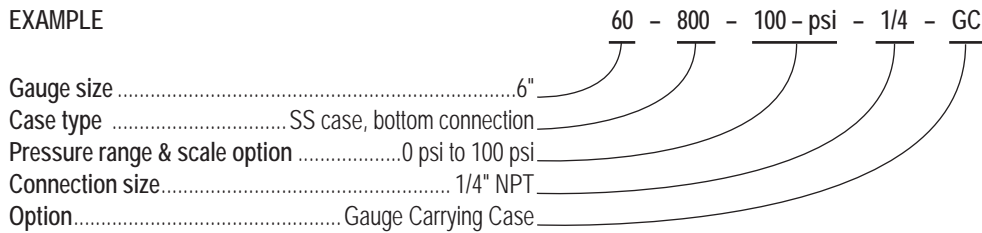

60-800*

60-800 Front Flange

60-800 Rear Flange

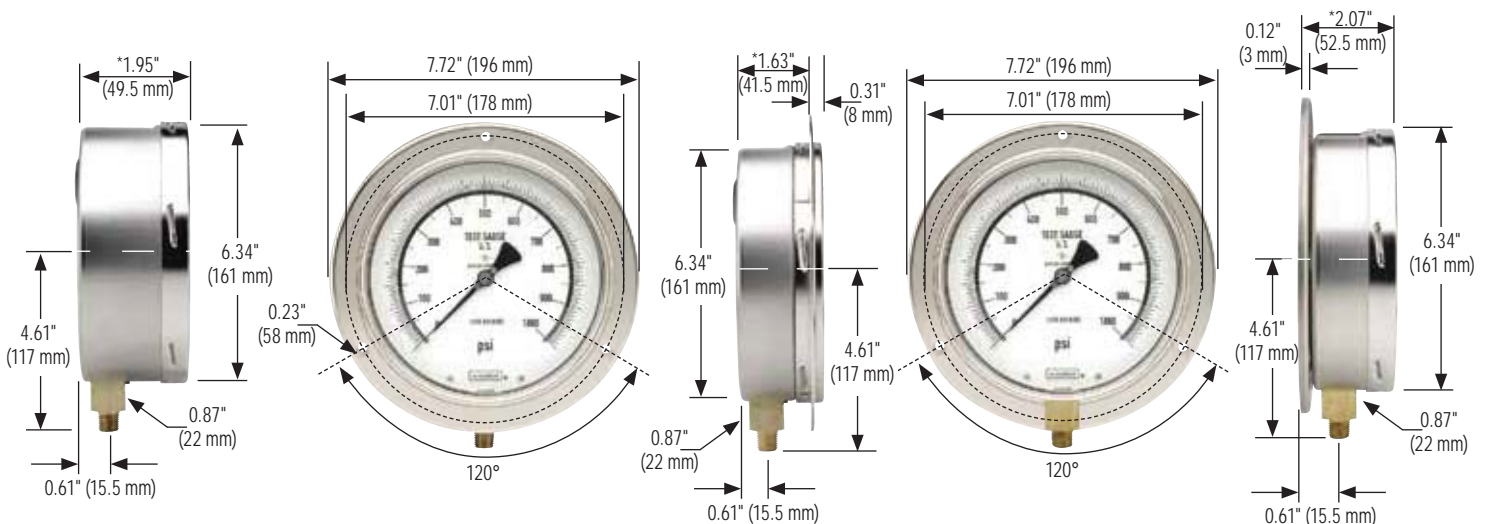

*For ranges ≤60 psi and ≥1,500 psi, increase by 0.63" (16 mm)

ABS & Stainless Steel Case, Liquid Filled



900 SERIES

- High quality liquid filled gauge
- Vacuum and compound ranges through 0 psi to 15,000 psi
- 1-1/2", 2", 2-1/2" and 4" gauge sizes
- Impact-resistant ABS and stainless steel case
- Copper alloy and brass wetted parts

OPERATING SPECIFICATIONS

1. Working Pressure Limitations

a. Dynamic Pressure

The working pressure should be limited to 60% of the dial range.

b. Static Pressure

The working pressure, where no sharp fluctuations occur, should be limited to 90% of the dial range

APPLICATIONS

- Automotive
- Construction
- Hydraulics & pneumatics
- Power generation
- Transportation
- Water management

	SERIES	SPECIFICATIONS
Pressure ranges	900 Series (all)	Vacuum and compound ranges through 0 psi to 15,000 psi
Accuracy	15-910	±2.5% full scale
	25-900, 25-910, 25-901, 25-911	±1.6% full scale
	40-901, 40-911	±1% full scale
Temperature ranges*	900 Series (all)	Media -4 °F to 140 °F (-20 °C to 60 °C) Glycerin fill -40 °F to 140 °F (-40 °C to 60 °C) Special fill Ambient -4 °F to 140 °F (-20 °C to 60 °C) Glycerin fill -40 °F to 140 °F (-40 °C to 60 °C) Special fill
Measuring element	900 Series (up to 600 psi)	Copper alloy C-Type Bourdon tube
	900 Series (> 600 psi)	Coiled safety tube
Connection	15-910	1/8" NPT, brass
	25-900, 25-910, 25-901, 25-911	1/4" NPT or 7/16"-20 adjustable, brass
	40-901, 40-911	1/4" NPT, brass 1/2" NPT, brass
Case	15-910, 25-900, 25-910	ABS with safety relief plug
	25-901, 25-911, 40-901, 40-911	304 stainless steel
Bezel	25-901, 25-911, 40-901, 40-911	304 stainless steel
Lens	15-910, 25-900, 25-910	Acrylic; ultrasonically welded to the case
	25-901, 25-911	Polycarbonate
	40-901, 40-911	Instrument glass
Pointer	15-910, 25-900, 25-910, 25-901, 25-911	Molded plastic
	40-901, 40-911	Balanced aluminum, black finish
Dial	15-910, 25-900, 25-910, 25-901, 25-911	Molded plastic, white background with black primary scale & red secondary scale. UV resistant
	40-901, 40-911	Aluminum, white background with black primary scale & red secondary scale. UV resistant.
Movement	15-910, 25-900, 25-910, 25-901, 25-911	Brass and nylon with highly polished bearing surfaces
Fill liquid**	900 Series (all)	Glycerin

For details on accuracy/standard dial configuration and dial layouts, see pages 54-59.

* For every 18 °F (10 °C) shift in temperature from which the gauge is calibrated, the user can experience up to ±0.4% additional error.

** See page 53 for gauge fill options.

ORDERING INFORMATION					
GAUGE SIZES	15 1-1/2"	20 2"	25 2-1/2"	40 4"	
CASE TYPES	900 ABS Case, bottom connection		910 ABS Case, back connection		
	901 SS Case, bottom connection		911 SS Case, back connection		
PRESSURE RANGES	30vac -30 inHg to 0 psi	100 0 psi to 100 psi	5000 0 psi to 5,000 psi	10 0 bar to 10 bar	
	30/15 -30 inHg to 0 to 15 psi	160 0 psi to 160 psi	6000 0 psi to 6,000 psi	16 0 bar to 16 bar	
	30/30 -30 inHg to 0 to 30 psi	200 0 psi to 200 psi	7500 0 psi to 7,500 psi	25 0 bar to 25 bar	
	30/60 -30 inHg to 0 to 60 psi	300 0 psi to 300 psi	10000 0 psi to 10,000 psi	40 0 bar to 40 bar	
	30/100 -30 inHg to 0 to 100 psi	400 0 psi to 400 psi	15000 0 psi to 15,000 psi	60 0 bar to 60 bar	
	30/160 -30 inHg to 0 to 160 psi	600 0 psi to 600 psi	-1 -1 bar to 0 bar	100 0 bar to 100 bar	
	30/200 -30 inHg to 0 to 200 psi	800 0 psi to 800 psi	1 0 bar to 1 bar	160 0 bar to 160 bar	
	30/300 -30 inHg to 0 to 300 psi	1000 0 psi to 1,000 psi	1.6 0 bar to 1.6 bar	250 0 bar to 250 bar	
	15 0 psi to 15 psi	1500 0 psi to 1,500 psi	2.5 0 bar to 2.5 bar	400 0 bar to 400 bar	
	30 0 psi to 30 psi	2000 0 psi to 2,000 psi	4 0 bar to 4 bar	600 0 bar to 600 bar	
	60 0 psi to 60 psi	3000 0 psi to 3,000 psi	6 0 bar to 6 bar	1000 0 bar to 1,000 bar	
SCALE OPTIONS	psi psi single scale psi/bar psi/bar dual scale	psi/kg/cm ² psi/kg/cm ² dual scale	bar/psi bar/psi dual scale	psi/kPa psi/kPa dual scale	
CONNECTION SIZES	1/8 1/8" NPT	1/4 1/4" NPT	1/2 1/2" NPT	SST SAE J1926-3:7/16-20 Adjustable*	
OPTIONS	PMC Steel Panel Mount Clamp	AP Adjustable Pointer	SSFF 304SS Front Flange	BP3 Brass Press Fit Orifice 0.3 mm	
	SPMC 304SS Panel Mount Clamp	MIP Maximum Indicating Pointer	SSRF 304SS Rear Flange	BT5 Brass Threaded Orifice 0.5 mm	
	SSBU Stainless Steel Bezel & U-clamp	SP Red Set Pointer	LM Laser Marking	BT8 Brass Threaded Orifice 0.8 mm	
	SSB Stainless Steel Bezel	SG Safety Glass Lens	ST Stainless Steel Tagging		
	SSCR 304SS Cover Ring	BLFF Black Front Flange			

Please consult your local NOSHOK Distributor or NOSHOK, Inc. for availability and delivery information.

NOTE: Refer to 900 Series Options & Accessories chart on page 53 for availability by series number.

* Includes FKM o-ring

EXAMPLE

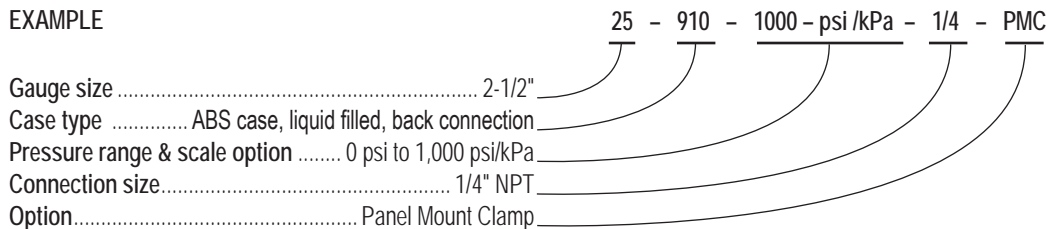

25-900

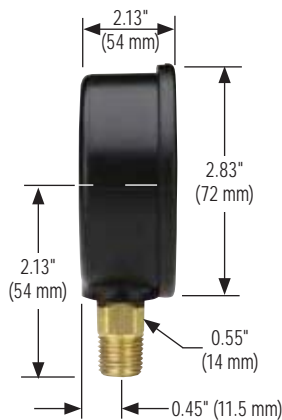

25-901



40-901



Dimensions

15-910

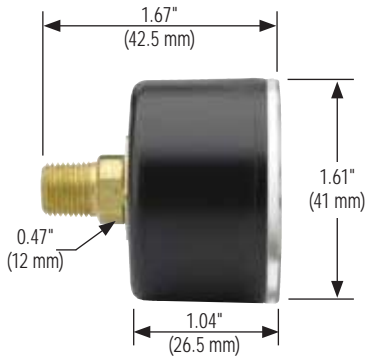

25-910

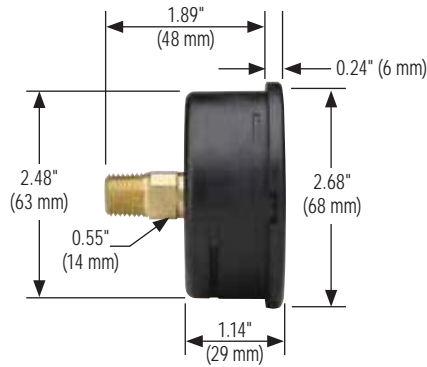

25-911

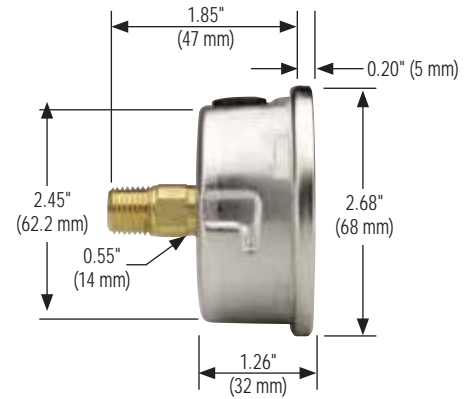

40-901 Front Flange

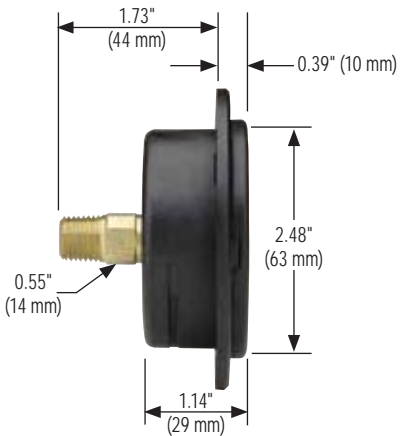
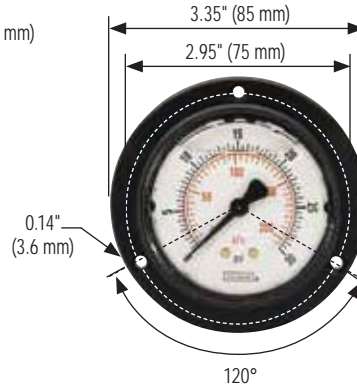
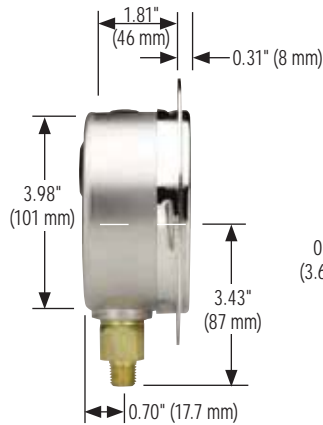
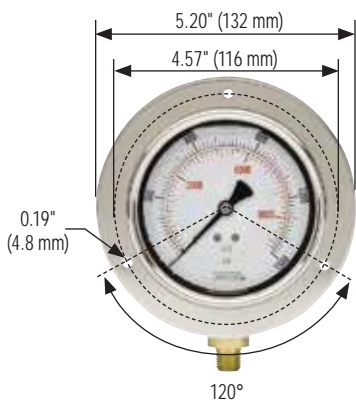

25-911 Front Flange

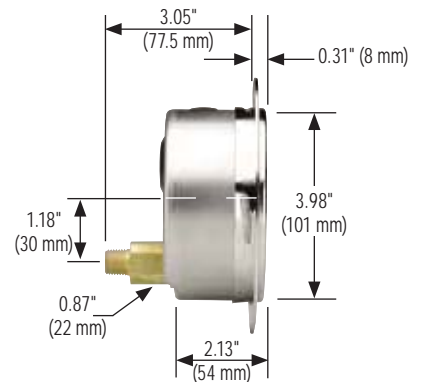
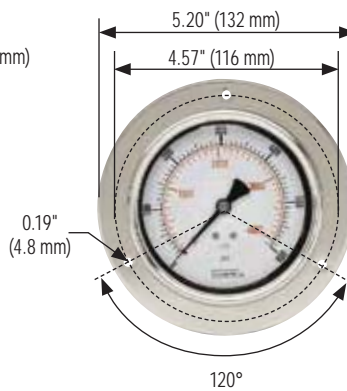
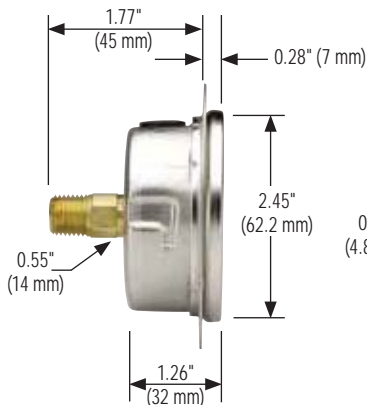
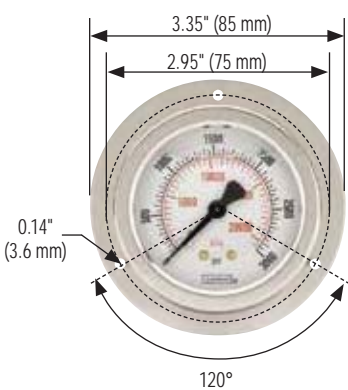

40-901 Rear Flange

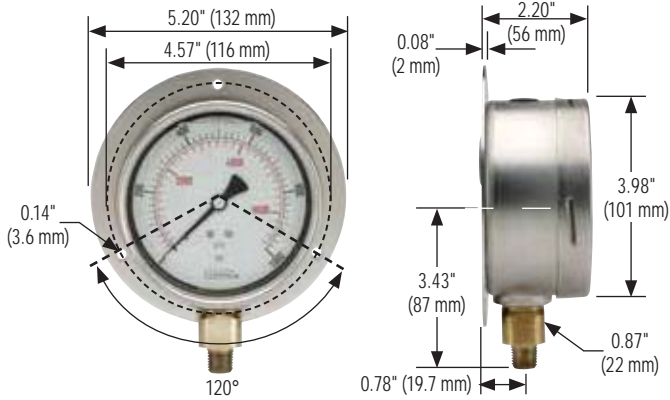

40-911 Rear Flange

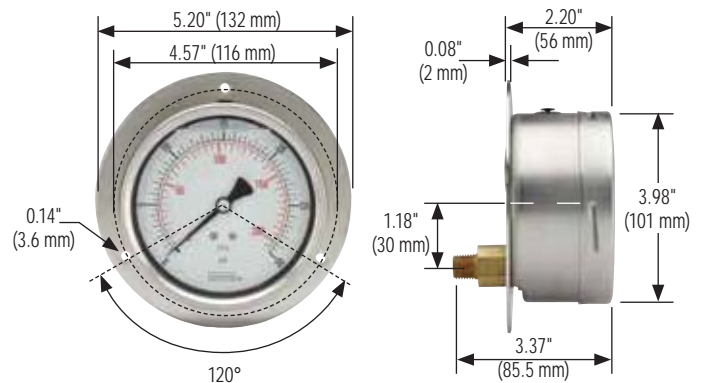

25-911 Flange Ring

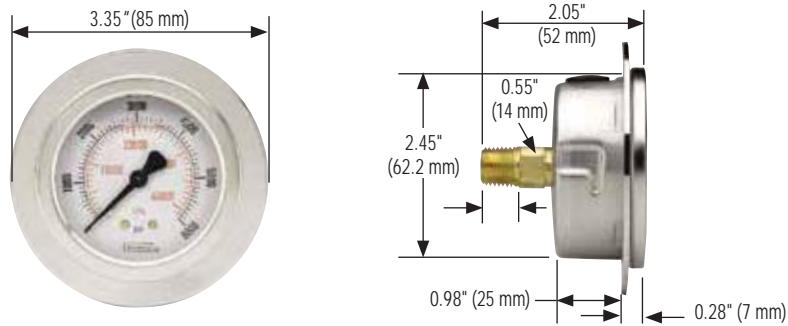

25-910 Panel Mount Clamp

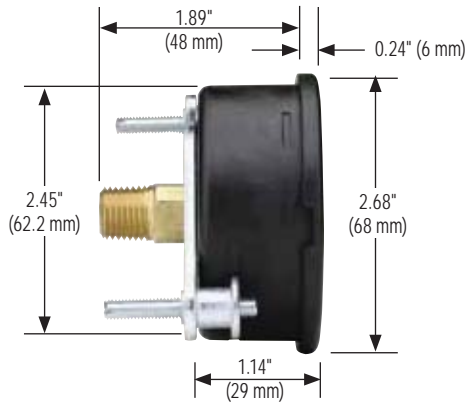

25-911 Panel Mount Clamp

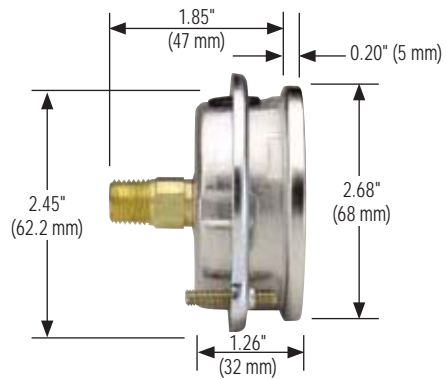

40-911

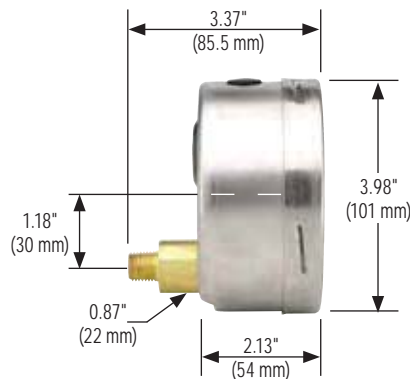

Piston Type

1000 SERIES

- High working static pressure dry or liquid-filled gauge
- Ranges from 0 psid to 5 psid through 0 psid to 100 psid
- 2-1/2" and 4-1/2" gauge sizes
- Fiberglass reinforced thermoplastic case
- Standard black anodized aluminum wetted parts



APPLICATIONS

- Back flow testing
- Heat exchangers
- Filter monitoring
- Flow indication
- Level indication

SPECIFICATIONS

Pressure ranges	0 psid to 5 psid through 0 psid to 100 psid
Max. working static pressure	6,000 psig
Accuracy	±2% of full scale on rising pressure
Temperature ranges	Media -40 °F to 200 °F (-40 °C to 93 °C) Ambient -40 °F to 200 °F (-40 °C to 93 °C) Storage -40 °F to 200 °F (-40 °C to 93 °C)
Measuring element	316 stainless steel and ceramic piston/magnet
O-ring material	FKM
Connection	1/4" NPT female, back connection
Sensor housing material	Black anodized aluminum
Case	Fiberglass reinforced thermoplastic
Bezel	Fiberglass reinforced thermoplastic
Lens	Acrylic
Pointer	Balanced aluminum, black finish
Dial	Aluminum, white background with black scale
Movement	Magnetic
Gauge fill fluid	Glycerin

ORDERING INFORMATION				
GAUGE SIZES & SERIES	25 - 10	2-1/2"	45 - 10	4-1/2"
CONNECTION LOCATIONS	1	Back	2	Side
CONNECTION SIZE	2 1/4" NPT female			
PRESSURE RANGES	P5	0 psid to 5 psid	P20	0 psid to 20 psid
	P10	0 psid to 10 psid	P25	0 psid to 25 psid
	P15	0 psid to 15 psid	P30	0 psid to 30 psid
SENSOR HOUSING MATERIALS	A	Aluminum, black	S	316L Stainless steel
O-RING MATERIALS	2	FKM	3	NBR
			4	EPDM
CASE MATERIAL	P Thermoplastic			
LENSES	1	Acrylic	2	Safety glass
			3	Maximum indicating pointer (MIP)
FILL FLUIDS (OPTIONAL)	GY	Glycerin	SL	Silicone
			HL	Halocarbon®

Please consult your local NOSHOK Distributor or NOSHOK, Inc. for availability and delivery information.

EXAMPLE

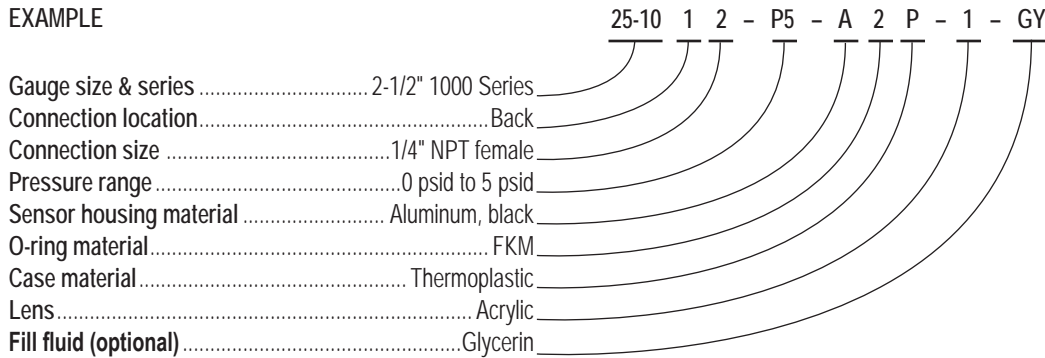

2-1/2" Gauge Panel Cut-Out Dimensions

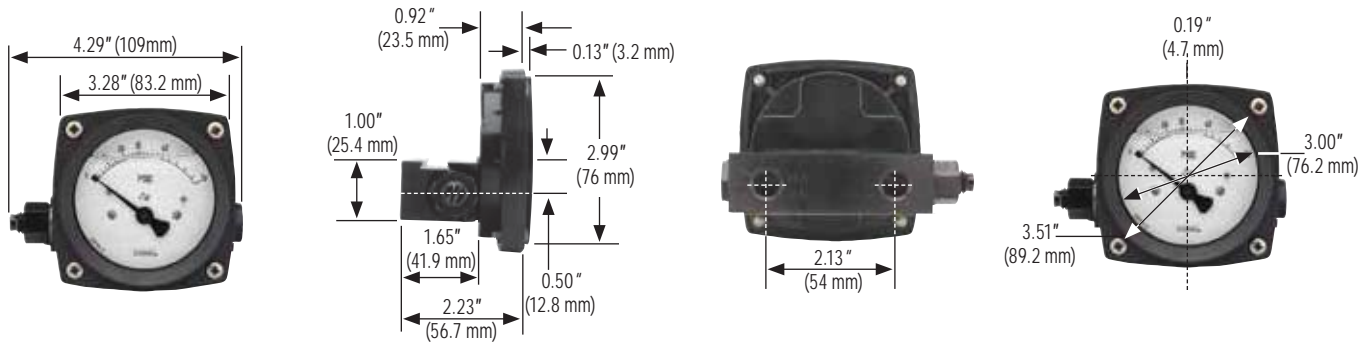

4-1/2" Gauge Panel Cut-Out Dimensions

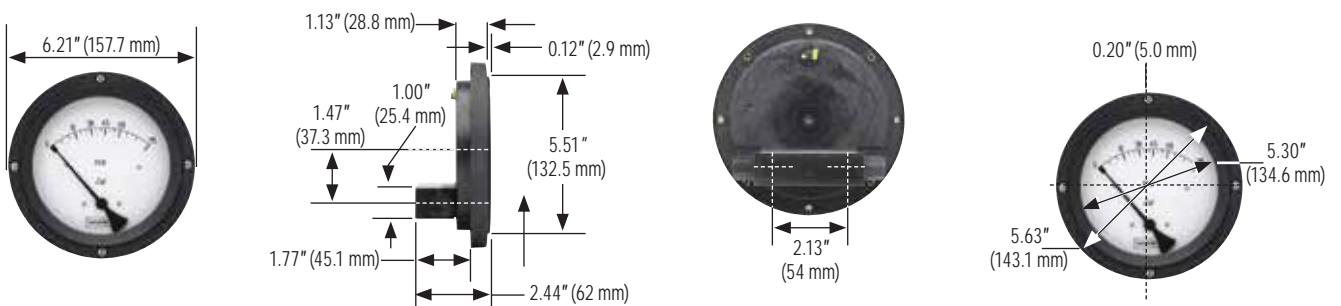

Diaphragm Type



1100 SERIES

- Moderate working static pressure dry or liquid-filled gauge
- Ranges from 0 inH₂O to 50 inH₂O through 0 psid to 100 psid
- 2-1/2" and 4-1/2" gauge sizes
- Fiberglass reinforced thermoplastic case
- Standard black anodized aluminum wetted parts

APPLICATIONS

- Back flow testing
- Heat exchangers
- Filter monitoring
- Flow indication
- Level indication

SPECIFICATIONS

Pressure ranges	0 inH ₂ O to 50 inH ₂ O through 0 psid to 100 psid
Max. working static pressure	3,000 psig
Accuracy	±2% full scale for ranges 0 psid to 15 psid & above ±5% full scale for ranges below 0 psid to 15 psid
Temperature ranges	Media -40 °F to 200 °F (-40 °C to 93 °C) Ambient -40 °F to 200 °F (-40 °C to 93 °C) Storage -40 °F to 200 °F (-40 °C to 93 °C)
Measuring element	316 stainless steel and ceramic magnet
O-ring material	NBR
Connection	1/4" NPT female, back connection
Sensor housing material	Black anodized aluminum
Case	Fiberglass reinforced thermoplastic
Bezel	Fiberglass reinforced thermoplastic
Lens	Acrylic
Pointer	Balanced aluminum, black finish
Dial	Aluminum, white background with black scale
Movement	Magnetic
Gauge fill fluid	Glycerin

ORDERING INFORMATION				
GAUGE SIZES & SERIES	25 - 11	2-1/2"	45 - 11	4-1/2"
CONNECTION LOCATIONS	0	Top & bottom	1	Back
CONNECTION SIZE	2	1/4" NPT female		
PRESSURE RANGES	W50	0 inH ₂ O to 50 inH ₂ O	W300	0 inH ₂ O to 300 inH ₂ O
	W75	0 inH ₂ O to 75 inH ₂ O	W400	0 inH ₂ O to 400 inH ₂ O
	W100	0 inH ₂ O to 100 inH ₂ O	P5	0 psid to 5 psid
	W200	0 inH ₂ O to 200 inH ₂ O	P10	0 psid to 10 psid
			P15	0 psid to 15 psid
			P25	0 psid to 25 psid
			P30	0 psid to 30 psid
			P50	0 psid to 50 psid
SENSOR HOUSING MATERIALS	A	Aluminum, black	S	316L Stainless steel
O-RING MATERIALS	2	FKM	3	NBR
CASE MATERIAL	P	Thermoplastic		
LENSES	1	Acrylic	2	Safety glass
			3	Maximum indicating pointer (MIP)
FILL FLUIDS (optional)	GY	Glycerin	SL	Silicone
			HL	Halocarbon®

Please consult your local NOSHOK Distributor or NOSHOK, Inc. for availability and delivery information.

EXAMPLE

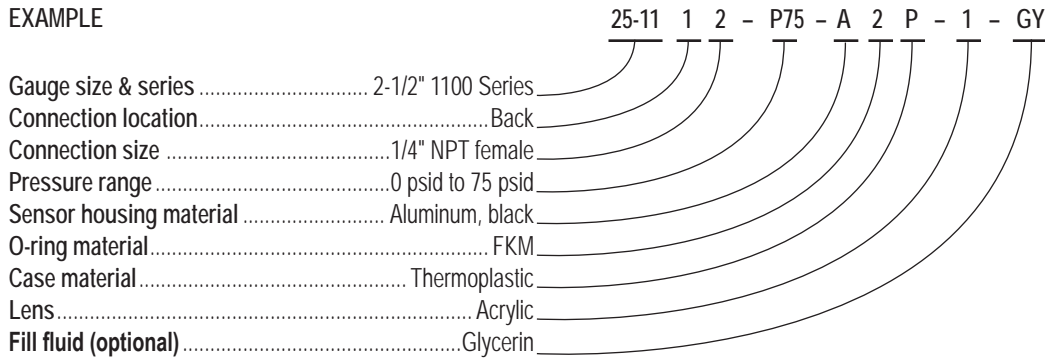

2-1/2" Gauge Panel Cut-Out Dimensions

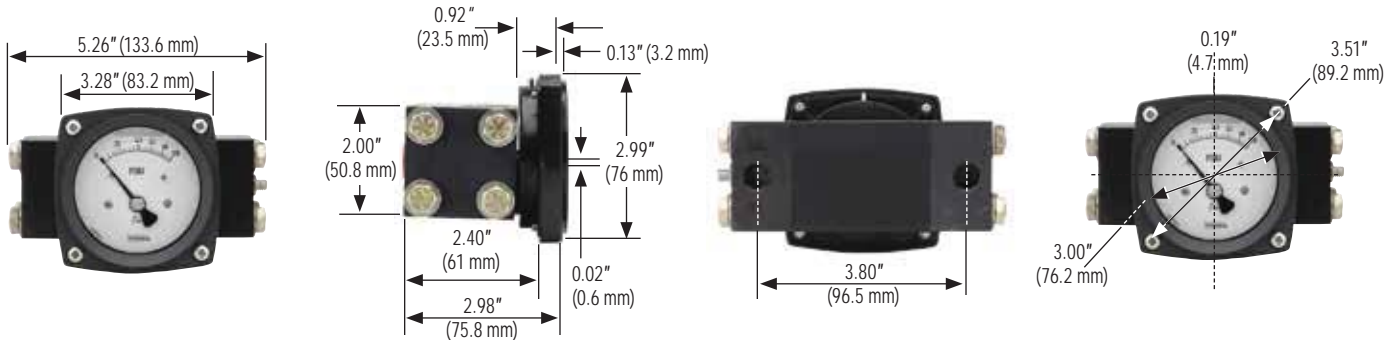

4-1/2" Gauge Panel Cut-Out Dimensions

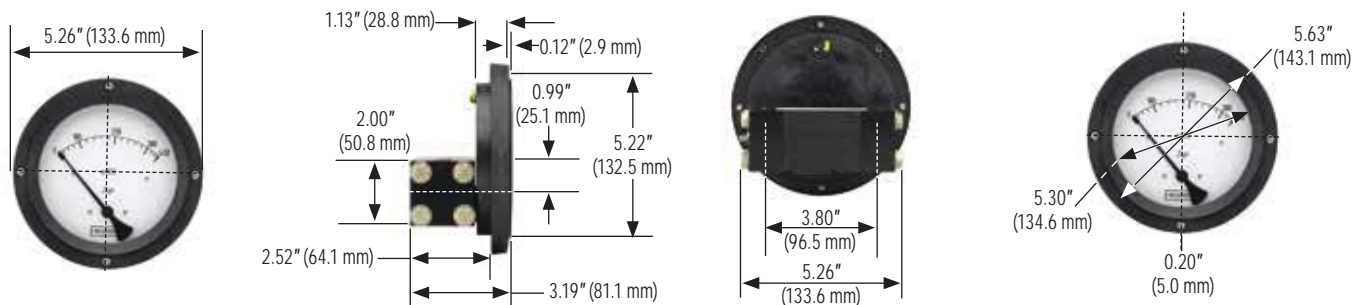

Membrane Type High Static Pressure



1200 SERIES

- Rugged, high working static pressure dry or liquid-filled gauge
- Ranges from 0 inH₂O to 100 inH₂O through 0 psid to 600 psid
- 4-1/2" and 6" gauge sizes
- Standard black anodized aluminum case
- 316 stainless steel wetted parts

APPLICATIONS

- Back flow testing
- Chemical processing
- Cryogenic systems
- Filter monitoring
- Flow indication
- Oilfield & offshore

SPECIFICATIONS

Pressure ranges	0 inH ₂ O to 100 inH ₂ O through 0 psid to 600 psid
Max. working static pressure	3,000 psig
Accuracy	±1% of full scale or rising pressure
Temperature ranges	Media -40 °F to 200 °F (-40 °C to 93 °C) Ambient -40 °F to 200 °F (-40 °C to 93 °C) Storage -40 °F to 200 °F (-40 °C to 93 °C)
Measuring element	Monel 500
O-ring material	PTFE
Connection	1/4" NPT female, back connection
Sensor housing material	316L stainless steel
Case	Black anodized aluminum
Bezel	316L stainless steel
Lens	Polycarbonate
Pointer	Balanced aluminum, black finish
Dial	Aluminum, white background with black scale
Movement	Stainless steel
Gauge fill fluid	Glycerin

ORDERING INFORMATION			
GAUGE SIZES & SERIES	45 - 12 4-1/2"	60 - 12 6"	
CONNECTION LOCATIONS	0 Top & bottom	1 Back	
CONNECTION SIZE	2 1/4" NPT female		
PRESSURE RANGES	W100 0 inH ₂ O to 100 inH ₂ O	W400 0 inH ₂ O to 400 inH ₂ O	P100 0 psid to 100 psid
	W150 0 inH ₂ O to 150 inH ₂ O	P15 0 psid to 15 psid	P230 0 psid to 230 psid
	W200 0 inH ₂ O to 200 inH ₂ O	P30 0 psid to 30 psid	P300 0 psid to 300 psid
	W300 0 inH ₂ O to 300 inH ₂ O	P60 0 psid to 60 psid	P400 0 psid to 400 psid
SENSOR HOUSING MATERIAL	S 316L Stainless steel		
O-RING MATERIAL	1 PTFE		
CASE MATERIALS	A Aluminum, black	S 316L Stainless steel	
LENSES	1 Polycarbonate	2 Safety glass	
FILL FLUIDS (optional)	GY Glycerin	SL Silicone	HL Halocarbon®

Please consult your local NOSHOK Distributor or NOSHOK, Inc. for availability and delivery information.

EXAMPLE

60-12 0 2 - P15 - S 1 A - 2 - GY

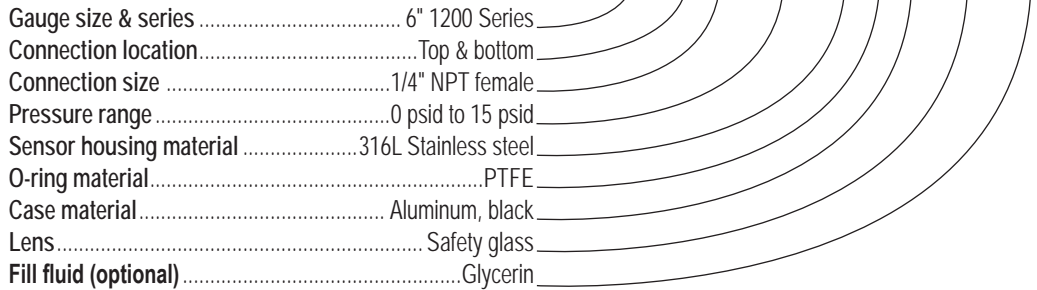

4-1/2" Gauge Panel Cut-Out Dimensions

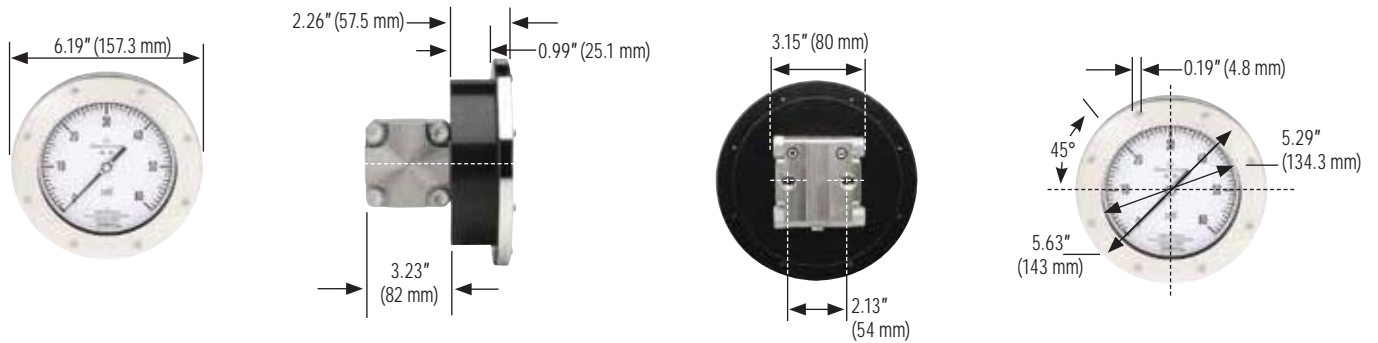

6" Gauge Panel Cut-Out Dimensions

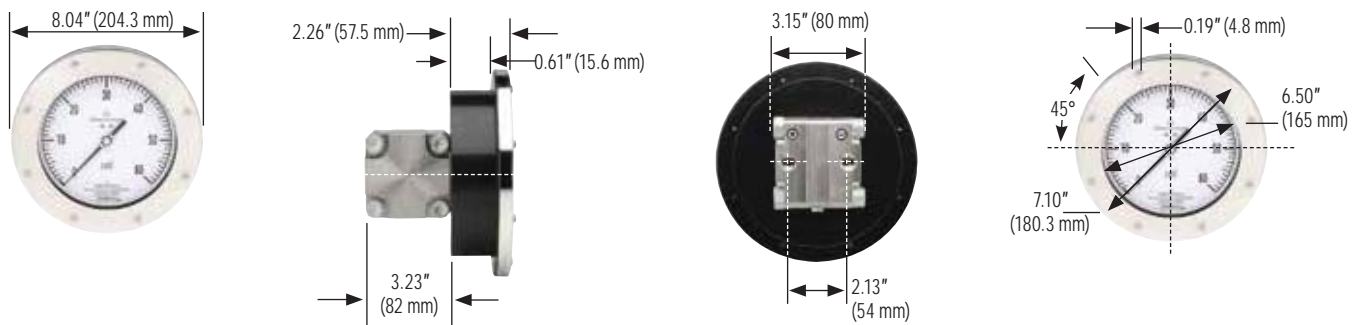

Membrane Type Nominal Static Pressure



1300 SERIES

- Rugged, moderate working static pressure dry or liquid-filled gauge
- Ranges from 0 inH₂O to 100 inH₂O through 0 psid to 400 psid
- 4-1/2" and 6" gauge sizes
- Standard black anodized aluminum case
- 316 stainless steel wetted parts

APPLICATIONS

- Back flow testing
- Chemical processing
- Cryogenic systems
- Filter monitoring
- Flow indication
- Oilfield & offshore

SPECIFICATIONS

Pressure ranges	0 inH ₂ O to 100 inH ₂ O through 0 psid to 400 psid
Max. working static pressure	600 psig
Accuracy	±1% of full scale on rising pressure
Temperature ranges	Media -40 °F to 200 °F (-40 °C to 93 °C) Ambient -40 °F to 200 °F (-40 °C to 93 °C) Storage -40 °F to 200 °F (-40 °C to 93 °C)
Measuring element	316L stainless steel – NACE compliant
O-ring material	PTFE
Connection	1/4" NPT female, dual top & bottom
Sensor housing material	316L stainless steel
Case	Black anodized aluminum
Bezel	316L stainless steel
Lens	Polycarbonate
Pointer	Balanced aluminum, black finish
Dial	Aluminum, black background with white scale
Movement	Stainless steel
Gauge fill fluid	Glycerin

ORDERING INFORMATION			
GAUGE SIZES & SERIES	45 - 13 4-1/2"	60 - 13 6"	
CONNECTION LOCATIONS	0 Top & bottom	1 Back	
CONNECTION SIZE	2 1/4" NPT female		
PRESSURE RANGES	W100 0 inH ₂ O to 100 inH ₂ O	W400 0 inH ₂ O to 400 inH ₂ O	P100 0 psid to 100 psid
	W150 0 inH ₂ O to 150 inH ₂ O	P15 0 psid to 15 psid	P230 0 psid to 230 psid
	W200 0 inH ₂ O to 200 inH ₂ O	P30 0 psid to 30 psid	P300 0 psid to 300 psid
	W300 0 inH ₂ O to 300 inH ₂ O	P60 0 psid to 60 psid	P400 0 psid to 400 psid
SENSOR HOUSING MATERIAL	S 316L Stainless steel		
O-RING MATERIALS	1 PTFE	2 FKM	3 NBR
CASE MATERIALS	A Aluminum, black	S 316L Stainless steel	
LENSES	1 Polycarbonate	2 Safety glass	
FILL FLUIDS (optional)	GY Glycerin	SL Silicone	HL Halocarbon®

Please consult your local NOSHOK Distributor or NOSHOK, Inc. for availability and delivery information.

EXAMPLE

40-13 0 2 - W100 - S 1 A - 2 - GY

- Gauge size & series 4" 1300 Series
- Connection location.....Top & bottom
- Connection size1/4" NPT female
- Pressure range0 inH₂O to 100 inH₂O
- Sensor housing material316L Stainless steel
- O-ring material.....PTFE
- Case material Aluminum, black
- Lens Safety glass
- Fill fluid (optional).....Glycerin

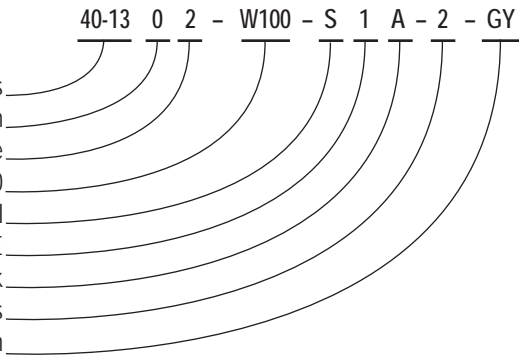

4-1/2" Gauge Panel Cut-Out Dimensions

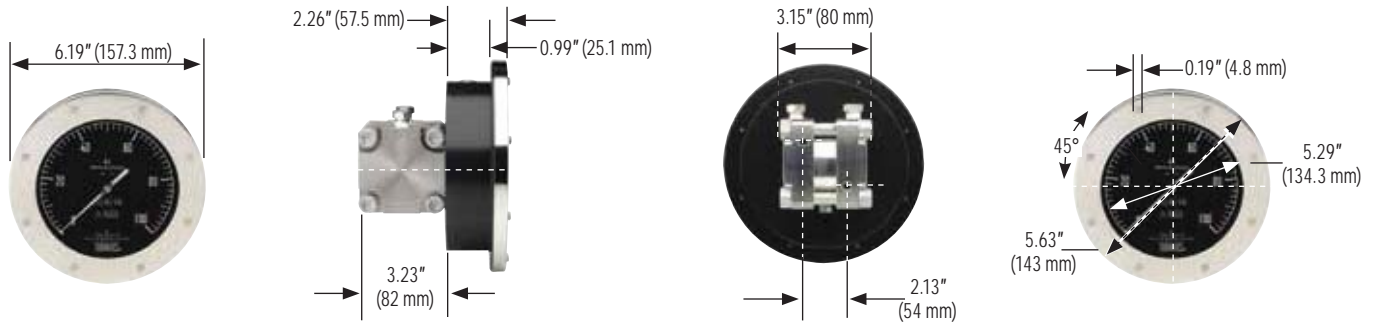

6" Gauge Panel Cut-Out Dimensions

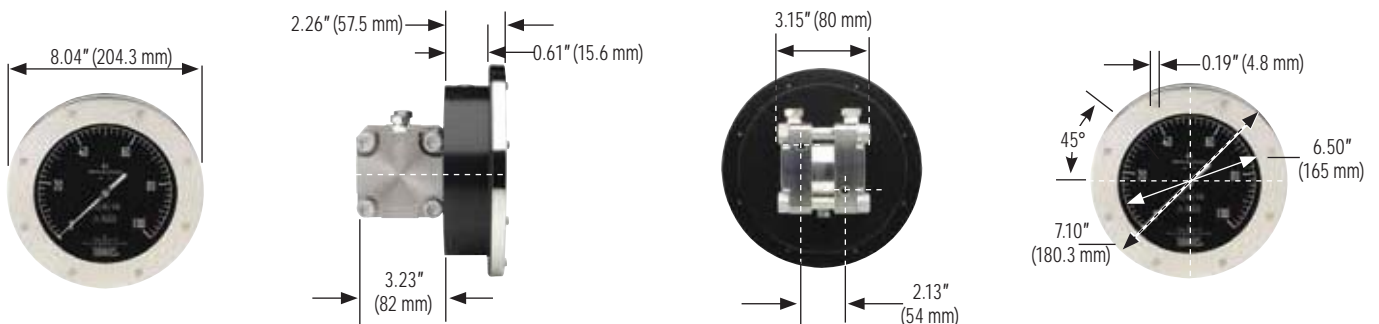

Dial Layouts

1000 Series 2-1/2"

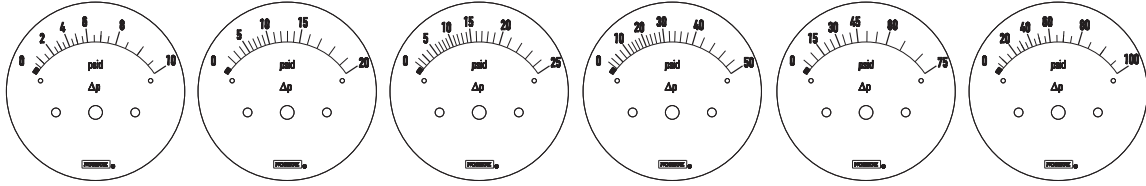

1000 Series 4-1/2"

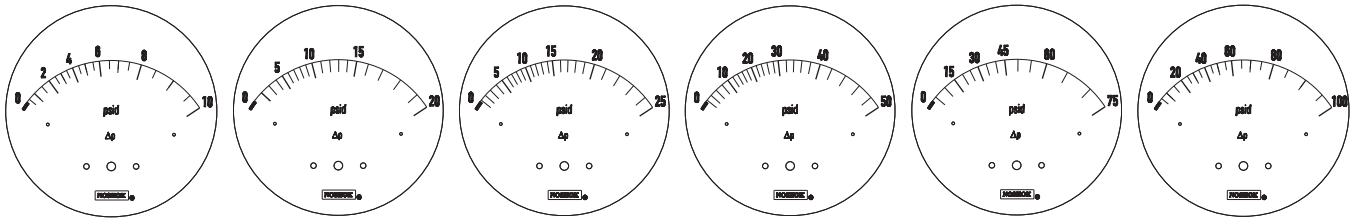

1100 Series 2-1/2"

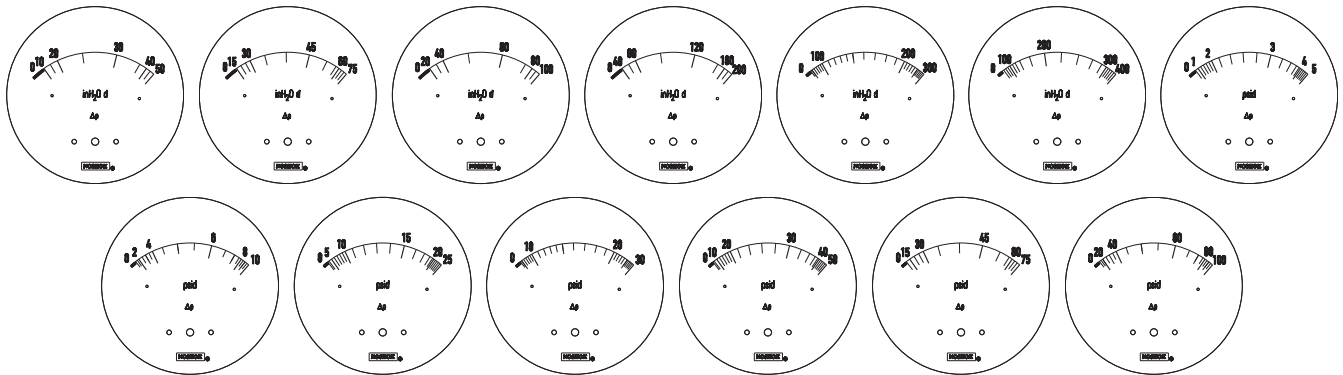

1100 Series 4-1/2"

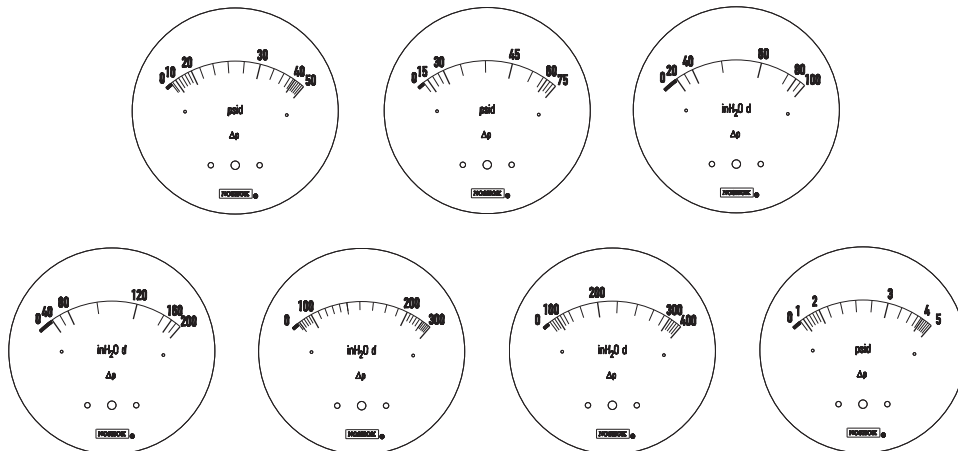

1100 Series 4-1/2"

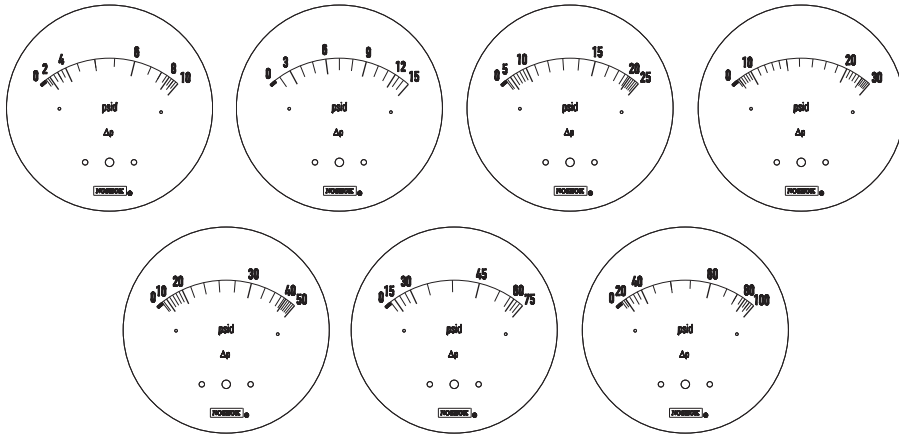

1200 Series 4-1/2"

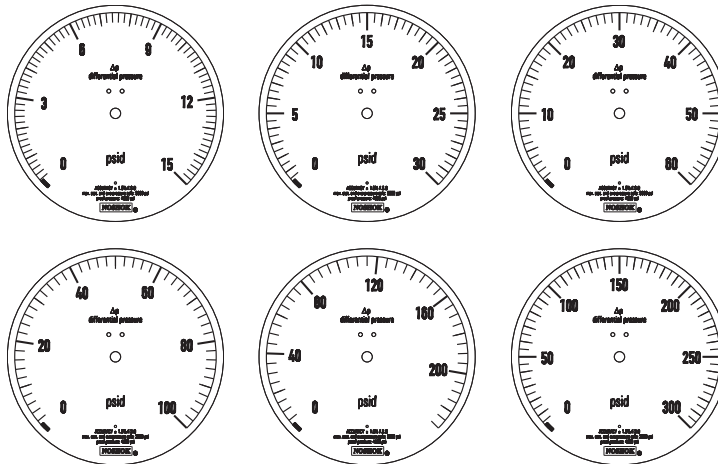

1300 Series 4-1/2"

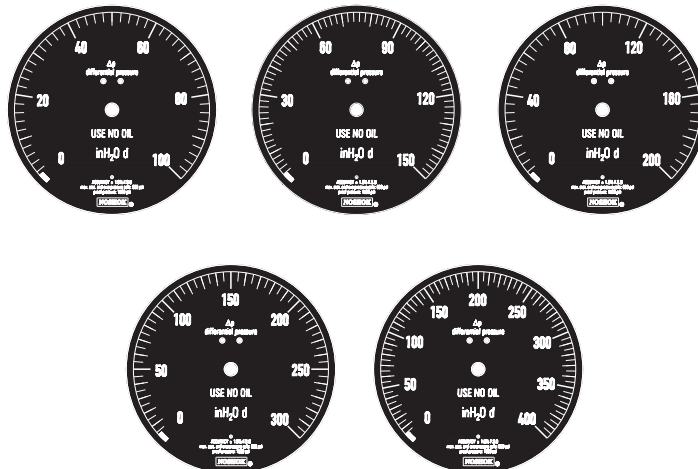



10 SERIES

- 3/4" clamp, dry gauge
- Ranges from 0 psig to 30 psig through 0 psig to 600 psig
- 2" gauge size
- Electropolished stainless steel case
- 316 stainless steel wetted parts
- Meets current standards for 3A and ASME BPE-2009
- C.I.P, S.I.P and Autoclave (only dry gauges are recommended for Autoclave)

APPLICATIONS

- Food & beverage processing
- Pasteurization systems
- Pharmaceutical
- Medical

SPECIFICATIONS

Pressure ranges	0 psig to 30 psig through 0 psig to 600 psig
Accuracy	±2.5% full scale
Temperature ranges	Media -40 °F to 300 °F (-40 °C to 150 °C) Ambient 25 °F to 140 °F (-4 °C to 60 °C) Storage 25 °F to 140 °F (-4 °C to 60 °C)
Measuring element	316 stainless steel Bourdon tube
Connection	3/4" ASME-BPE Sanitary Clamp, 316L stainless steel Diaphragm 316L stainless steel, electropolished to 32 µin Ra or better
Case	2" Electropolished 304 stainless steel
Cover ring	Electropolished 304 stainless steel
Lens*	Polycarbonate
Pointer	Balanced aluminum, black finish
Dial	Aluminum, white background, black print
Movement	Stainless steel
Fill liquid	Glycerin, USP Grade

*Note: Autoclave requires the addition of optional laminated safety glass lens

Diaphragm seal must be installed facing downward or in a vertical position for drainability.
Do not install diaphragm seal facing in an upward position.

ORDERING INFORMATION			
SERIES	100	10 Series fractional	
CLAMP SIZE	06	3/4"	
FILL LIQUID	1	Glycerin	Other food grade quality fill fluids available – please consult factory
GAUGE SIZE	20	2"	
PRESSURE RANGES	43	0 psig to 30 psig	55 0 psig to 160 psig
	46	0 psig to 60 psig	58 0 psig to 200 psig
	49	0 psig to 100 psig	61 0 psig to 300 psig
OPTIONS	0	None	3 Safety Glass Lens (Required for Autoclave applications)

Please consult your local NOSHOK Distributor or NOSHOK, Inc. for availability and delivery information.

EXAMPLE

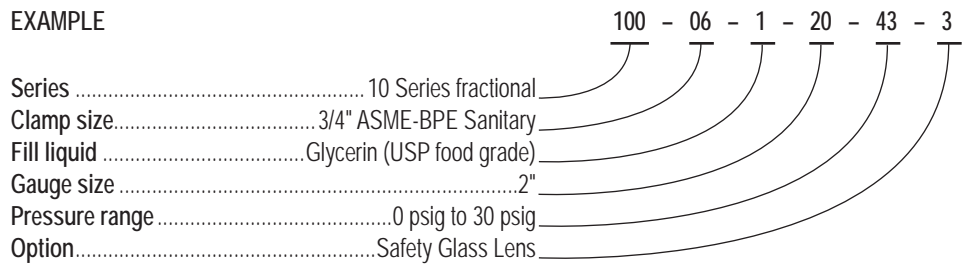

2" Gauge with 3/4" ASME-BPE Sanitary Clamp Connection

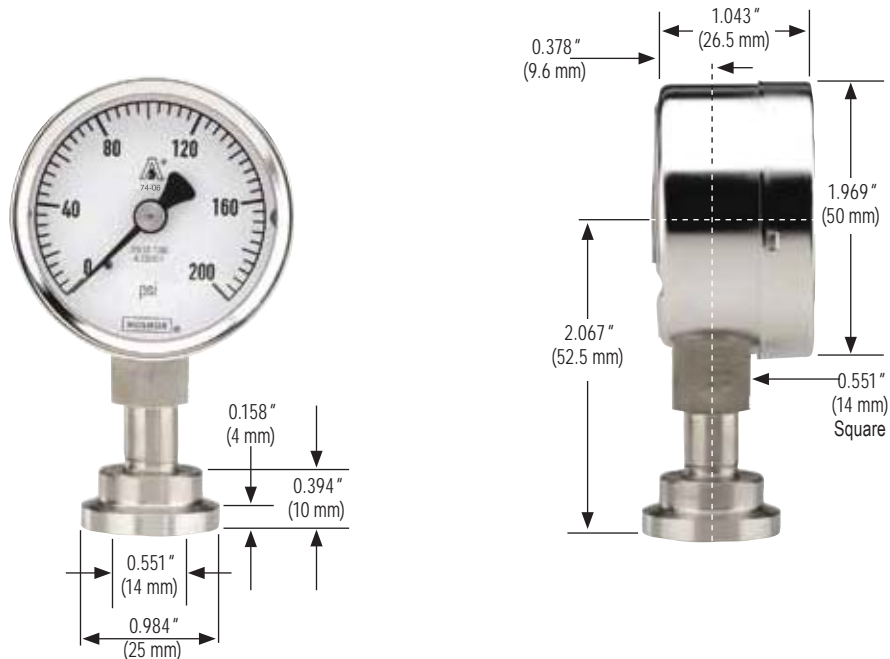



APPLICATIONS

- Food & beverage processing
- Pasteurization systems
- Pharmaceutical
- Medical

10 SERIES

- 1-1/2" and 2" clamp, fillable dry or liquid-filled gauge
- Ranges from -30 inHg to 0 psig through 0 psig to 600 psig
- 2-1/2" and 4" gauge sizes
- Electropolished stainless steel case
- 316 stainless steel wetted parts
- Meets current standards for 3A and ASME BPE-2009
- C.I.P, S.I.P and Autoclave (only dry gauges are recommended for Autoclave)

SPECIFICATIONS

Pressure ranges	-30 inHg to 0 psig through 0 to 600 psig
Accuracy	2-1/2" gauge $\pm 1.6\%$ full scale 4" gauge $\pm 1.0\%$ full scale
Temperature ranges	Media -40 °F to 300 °F (-40 °C to 150 °C) Ambient 25 °F to 140 °F (-4 °C to 60 °C) Storage 25 °F to 140 °F (-4 °C to 60 °C)
Measuring element	316 stainless steel "C" tube
Connection	1-1/2" or 2" ASME-BPE Sanitary Clamp, 316L stainless steel Diaphragm 316L stainless steel, electropolished to 32 μm Ra or better
Case	Electropolished 304 stainless steel
Bayonet ring	Electropolished 304 stainless steel
Lens	Safety glass
Pointer	Balanced aluminum, black finish
Dial	Aluminum, white background, black print
Movement	Stainless steel
Fill liquid	Glycerin, USP Grade

*Note: Autoclave requires the addition of optional laminated safety glass lens

Diaphragm seal must be installed facing downward or in a vertical position for drainability.
Do not install diaphragm seal facing in an upward position.

ORDERING INFORMATION								
SERIES	100	10 Series heavy-duty						
CLAMP SIZES	12	1-1/2"	16	2"				
FILL LIQUID	1	Glycerin	Other food grade quality fill fluids available – please consult factory					
GAUGE SIZES	25	2-1/2"	40 4"					
PRESSURE RANGES	01	-30 inHg to 0 psig*	16	-30 inHg to 160 psig				
	04	-30 inHg to 15 psig	19	-30 inHg to 200 psig				
	07	-30 inHg to 30 psig	22	-30 inHg to 300 psig				
	10	-30 inHg to 60 psig	40	0 psig to 15 psig*				
	13	-30 inHg to 100 psig	43	0 psig to 30 psig				
			46	0 psig to 60 psig	64	0 psig to 400 psig		
		49	0 psig to 100 psig	70	0 psig to 600 psig			
		55	0 psig to 160 psig					
		58	0 psig to 200 psig					
		61	0 psig to 300 psig					
GAUGE FILLS	0	None	1	Glycerin	2	Silicone	3	Mineral oil
(All food grade quality fill fluids)								
GAUGE OPTIONS	0	None	1	Max. Indicating Pointer	2	Adjustable Pointer**		

Please consult your local NOSHOK Distributor or NOSHOK, Inc. for availability and delivery information.

* Not available on 4" gauge and 1-1/2" ASME-BPE Sanitary Clamp

** Not available on 2-1/2" gauge

EXAMPLE

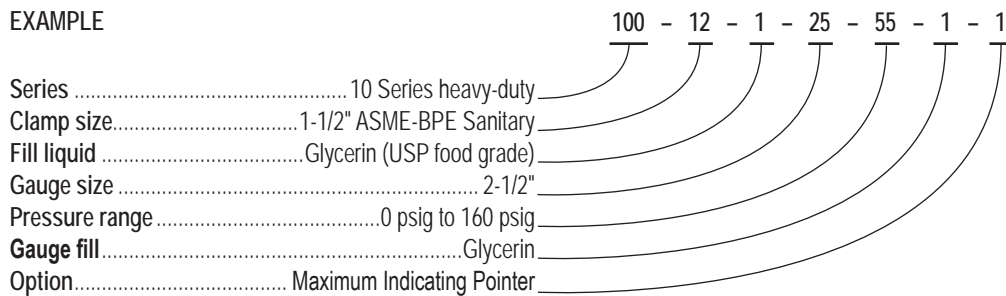

4 "Gauge with 2 "ASME-BPE Sanitary Clamp Connection 4 "Gauge with 1-1/2 "ASME-BPE Sanitary Clamp Connection

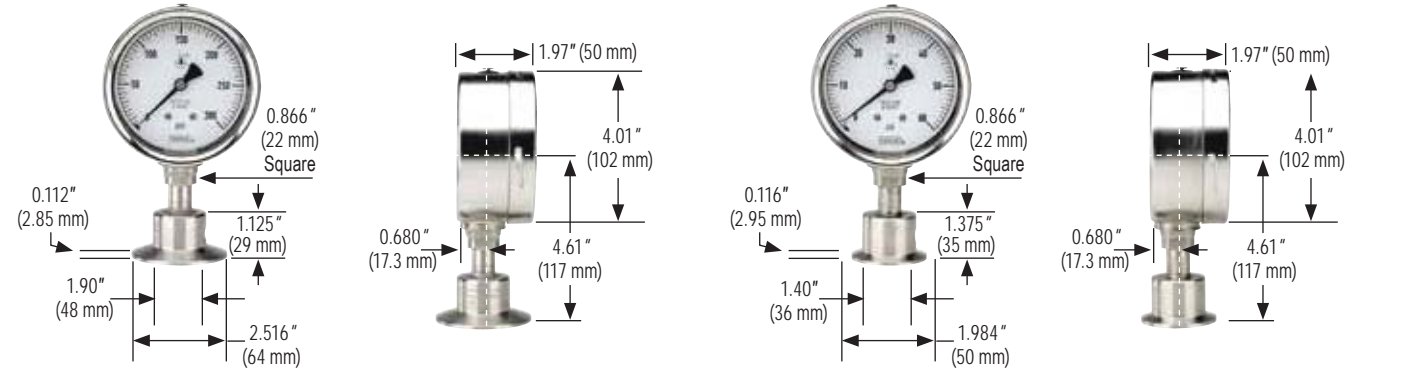

2-1/2 "Gauge with 2 "ASME-BPE Sanitary Clamp Connection 2-1/2 "Gauge with 1-1/2 "ASME-BPE Sanitary Clamp Connection

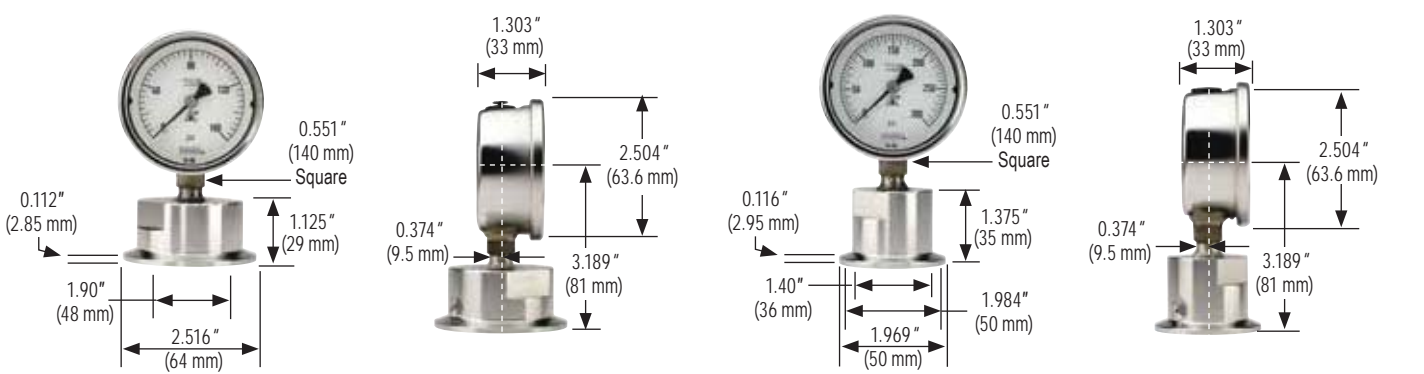



APPLICATIONS

- High pressure processing
- Pasteurization systems
- Homogenization systems

20 SERIES

- 1-1/8" flange, fillable dry or liquid-filled gauge
- Ranges from 0 psig to 1,000 psig through 0 psig to 15,000 psig
- 4" gauge size
- Electropolished stainless steel case
- 316 stainless steel wetted parts
- Meets current standards for 3A and ASME BPE-2009
- C.I.P, S.I.P and Autoclave (only dry gauges are recommended for Autoclave)

SPECIFICATIONS

Pressure ranges	0 psig to 1,000 psig through 0 psig to 15,000 psig
Accuracy	±1.0% full scale
Temperature ranges	Media -4 °F to 302 °F (-20 °C to 150 °C) Ambient 25 °F to 140 °F (-4 °C to 60 °C) Storage 25 °F to 140 °F (-4 °C to 60 °C)
Measuring element	316 stainless steel coiled safety tube
Connection	1-1/8" Homogenizer flange, 316L stainless steel Diaphragm 316L stainless steel, electropolished to 32 µin Ra or better
Case	Electropolished 304 stainless steel
Bayonet ring	Electropolished 304 stainless steel
Lens	Laminated safety glass
Pointer	Balanced aluminum, black finish
Dial	Aluminum, white background, black print
Movement	Stainless steel
Fill liquid	Glycerin, USP Grade

Diaphragm seal must be installed facing downward or in a vertical position for drainability. Do not install diaphragm seal facing in an upward position.

ORDERING INFORMATION				
SERIES	200	20 Series homogenizer		
CLAMP SIZE	42	1-1/8" flange		
FILL LIQUID	1	Glycerin Other food grade quality fill fluids available- please consult factory		
GAUGE SIZE	40	4"		
PRESSURE RANGES	73	79	85	91
	0 psig to 1,000 psig	0 psig to 2,000 psig	0 psig to 5,000 psig	0 psig to 10,000 psig
	76	82	88	94
	0 psig to 1,500 psig	0 psig to 3,000 psig	0 psig to 6,000 psig	0 psig to 15,000 psig
GAUGE FILLS	0	1	2	3
	None	Glycerin	Silicone	Mineral oil
	(All food grade quality fill fluids)			
GAUGE OPTIONS	0	1	2	
	None	Max. Indicating Pointer	Adjustable Pointer	

Please consult your local NOSHOK Distributor or NOSHOK, Inc. for availability and delivery information.

EXAMPLE

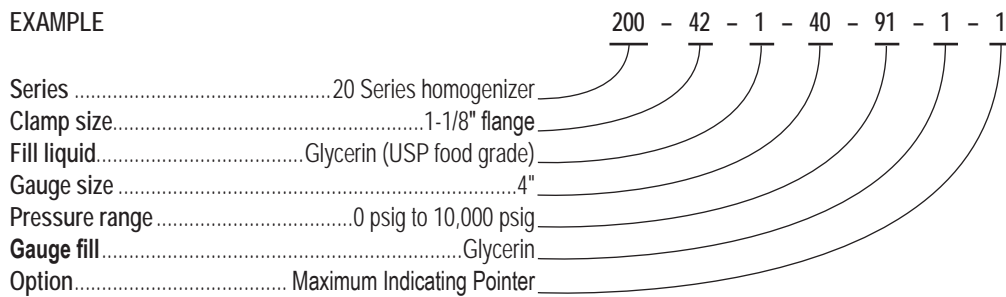

4 "Gauge with 1-1/8 "Homogenizer Flange

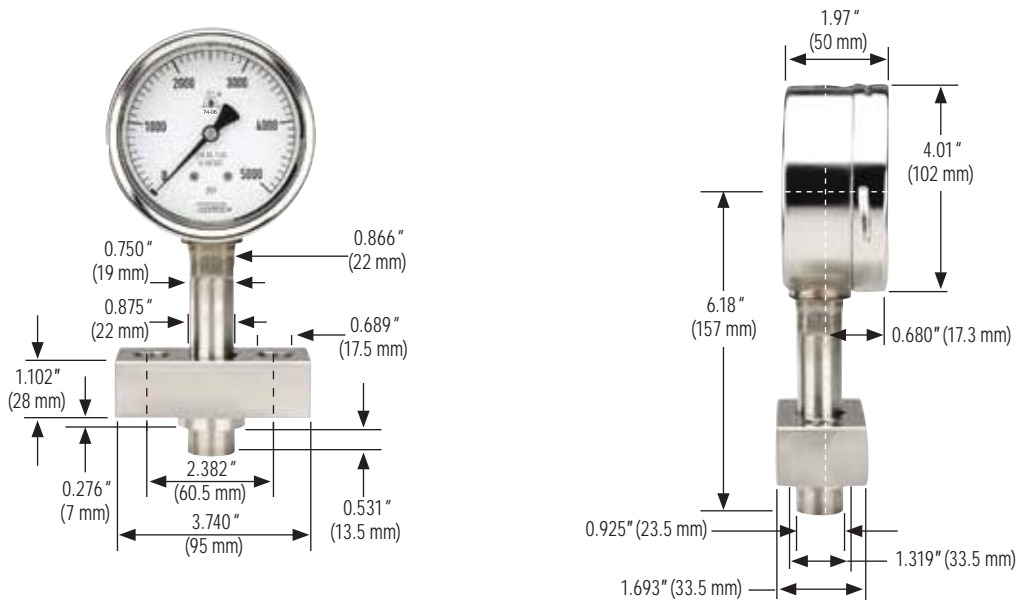

(Custom Flange Dimensions are Available to your Specifications - Please Consult Factory)

Dial Indicating Gauge Options & Accessories

PANEL MOUNTING FLANGES

- Many panel mounting options are available and can be installed in the field
- Options include:
 - Brass Front Flanges (BFF)
 - Black Painted Steel Front Flanges (BLFF)
 - Chrome Front Flanges (CFF)
 - Stainless Steel Front Flanges (SSFF)
 - Chrome Triangular Bezel with U-Clamp (CBU)
 - Black Painted Steel Triangular Bezels with U-Clamp (BBU-Clamp)
 - Stainless Steel Narrow Bezel Front Flanges (SSBU)
 - Panel Mount Clamps (PMC)
- Chrome-plated steel Adapter Rings (AR) are available in conjunction with several of these flanges to adapt to oversized panel cut outs, including:
 - Stainless Steel Flange Rings (SSFR)
 - Chrome-Plated Steel Flange Rings (CFR)
 - Black or Chrome Panel Mount Rings (BPMR & CPMR)
- Rear Flanges (RF) for front of panel mounting are also available as a factory installed option on some series



Panel Mount Clamp
20-110 PMC



Chrome Triangular Bezel
with U-Clamp

CASES & COVER RINGS

- The following cases and cover rings are available on many NOSHOK gauges as production options:
 - Black painted steel (BCR)
 - Chrome-plated steel (CCR)
 - 304 stainless steel (SSCR)
- Some NOSHOK gauges are also available with a solid front, safety case

LENSES

- A variety of lens options are available on many NOSHOK gauges as a production option:
 - Instrument glass lenses
 - Laminated safety glass lenses
 - Acrylic lenses
 - Homalite lenses (resistant to many industrial solvents)
 - A steel or stainless case and cover ring may be required when other than acrylic lenses are utilized



Cases and Cover Rings

MAXIMUM INDICATING POINTERS (MIP)

- An invaluable tool for identifying pressure spikes in a system
- Extremely helpful during system start up and troubleshooting
- MIPs add an additional $\pm 1\%$ error to the gauge because of the increased load on the Bourdon tube
- On ranges of 60 psi and lower, MIPs may double the allowed error of the gauge



Maximum Indicating Pointer

See the Gauges Accessories & Options Charts on pgs. 50-53 for availability on specific gauges

SET POINTERS (SP)

- Used to identify an operating minimum or maximum pressure or vacuum value
- Set pointers are available on many NOSHOK gauges

RUBBER CASE PROTECTORS (RCP)

- Ideal for gauges that are subjected to direct physical shock
- 2-1/2" covers are blue and 4" covers are black

ORIFICES

- Press-fit or threaded orifices in brass or 316 stainless steel are available on all NOSHOK pressure gauges
- Available with I.D.'s from 0.004" to 0.032" depending on the specific NOSHOK gauge
- Used in a gauge to restrict the flow of rapidly increasing and decreasing pressures, reducing the immediate effect of pulsations and pressure spikes
- Recommended for all dynamic applications

RECALIBRATORS & ADJUSTABLE POINTERS

- This option gives the user the capability of resetting the pointer by an adjustment screw accessible through the dial, or by a gear located on the pointer

OVERPRESSURE PROTECTION

- Overpressure protection of 3 times up to 10 times of the dial range is available on some NOSHOK gauges as a production option

AMMONIA REFRIGERATION GAUGES

- Ammonia and refrigeration gauges with dials reading in both pressure and temperature are available in 400/500 Series 2-1/2" and 4" sizes
- Refrigeration gauges with dials reading in pressure and temperature are available in 300, 400 and 500 Series for R-12 and R-22

LIQUID FILLING OPTIONS

- Many NOSHOK gauges are available with liquid filling options
- Standard fill is Glycerin
- Optional fill liquids include Dow Corning 200® Silicone and Halocarbon®

SPECIAL CONNECTIONS

- Available on most NOSHOK gauges
- Some examples include:
 - Metric threads
 - Female threads
 - Straight threads (flare or swivel type)
 - Special o-ring connections
- Please contact us with your requirements for prices, availability and minimum quantities

REID VAPOR TEST GAUGES

- Configuration includes a handle, special dial and special pressure port
- Available in 600/700 Series gauges with pressure ranges of 0 to 5 psi, 0 to 15 psi and 0 to 30 psi



Set Pointers



Rubber Case Protectors



Ammonia Gauges

See the Gauges Accessories & Options Charts on pgs. 50-53 for availability on specific gauges

Dial Indicating Gauge Options & Accessories

RECEIVER GAUGES

- 3 psi to 15 psi receiver gauges are available in both 600 Series (brass) and 700 Series (316 stainless steel)

METRIC DIALS & CUSTOMIZED SPECIAL DIALS

- Dual scale metric dials in psi/bar, psi/kPa and psi/kg/cm² are available on many NOSHOK gauges
- Other scales are available for specific sizes and ranges, such as single scale bar and kPa, refrigerant scales and altitude scales
- Please consult the factory for availability
- Customized special dials such as non-standard metric scale, tons of ram, lbs. of force, etc. are available in small quantities (as few as one piece) on some NOSHOK gauges

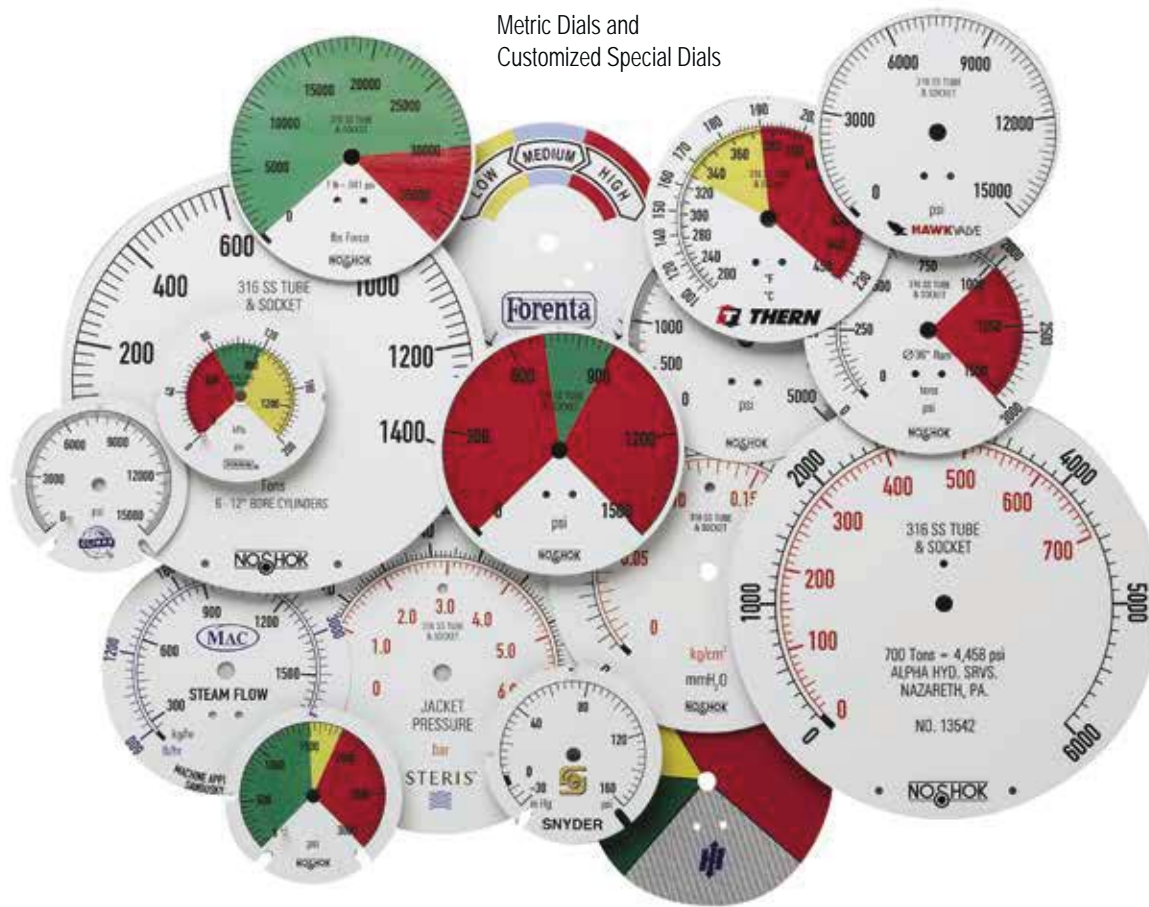

CERTIFIED CALIBRATION

- Available on all NOSHOK gauges
- Certified calibration provides the user with a serial numbered gauge along with a calibration sheet against a primary pressure standard
- Traceable to the National Institute of Standards and Technology

MAGNETIC SPRING CONTACT SWITCH (MSCS)

- An excellent choice when an accurate pressure switch is required in addition to a reliable pressure gauge
- Fully adjustable by the user
- These switches are actuated by the pressure gauge pointer to provide accurate field adjustment
- A removable adjustment key makes them tamper-proof
- They operate with an extremely broad power supply, AC or DC up to 250V max. (30W 50 VA), allowing them to be used virtually anywhere in the world in addition to very remote applications with only DC battery pack power available
- Standard units consist of (2) two magnetic spring switches; either one or both switches may be used:
 - Switch (1) one is normally closed
 - Switch (2) two is normally open with operation referenced on clockwise pointer motion
- Magnetic spring contact switches are available as a factory installed option on 40-400 Series, 40-410 Series, 40-901 Series dry and 40-911 Series dry
- The lowest full scale pressure range this switch may be used on is 0 psi to 60 psi because of the increased load on the pointer and Bourdon tube
- A mating 4-pin connector with 5' of 4-wire and color coded shielded cable is standard



40-901 Series Gauge with Magnetic Spring Contact Switch

SPECIFICATIONS

Type of power	A.C. or D.C. 24 to 250V max
Maximum amps	1.0 A
Maximum switching capacity	30 W/50 VA
Gauge accuracy	Add an additional $\pm 2\%$
Minimum magnet holding force	1g
Contact pin material	Silver Tungsten
Ambient temperature limitation	0 °F to 140 °F (-18 °C to 61 °C)
Minimum full scale pressure range	0-60 psi

APPLICATIONS

- Air compressors
- Gas compressors
- Hydraulic and pneumatic circuitry
- Die-cast machinery
- Plastic injection molding machinery

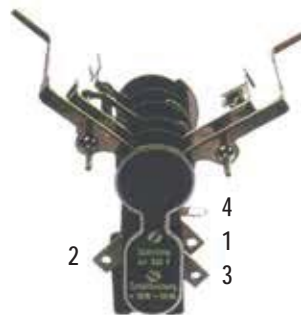
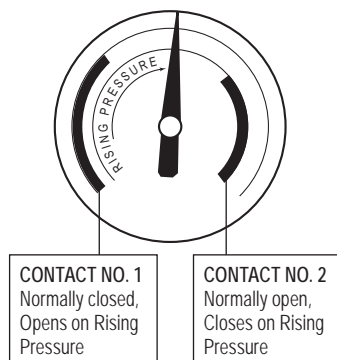











WIRING AND TERMINAL LOCATION

1. Contact Switch No. 1; Red or Black
2. Contact Switch No. 2; Blue
3. Power; Green or Brown
4. Ground; Yellow/Green Stripe

Options & Accessories by Gauge Series

100 SERIES ABS & STEEL CASE, DRY PRESSURE GAUGE ACCESSORIES

- = Option/accessory is available
- C = Consult factory for availability
- STD = Standard stock series specification

SERIES NO.	15-100	15-110	15-120	20-100	20-110	20-120	20-148	25-100	25-110	25-120	40-100
CONNECTION											
Installed Panel Mount Clamp (PMC)		•			•				•		
Uninstalled Panel Mount Clamp (15-110 PMC, 20-110 PMC, 25-110 PMC)		•			•				•		
Polished Stainless Steel Bezel (SSB)		•			•				•		
Black Rear Flange (BLRF)								•			•
Black Front Flange (BLFF) - ABS Case		•			•				•		
Chrome Front Flange (CFF) - ABS Case		•			•				•		
Black Front Flange (SBFF) - Steel Case	C			C	•			•	•		•
Chrome Front Flange (SCFF) - Steel Case	C	•		C	•			•	•		•
Black Steel Case (BSC)	C	•	STD	C	•	STD		•	•	STD	•
Stainless Steel Case (SSC)	C	•		C	•			•	•		
Chrome Case (CRC)	C	•		C	•			•	•		
Flat Sided ABS Case (FAC)		•			•				•		
Black Cover Ring (BCR)**	C	•		C	•			•	•		•
Stainless Steel Cover Ring (SSCR)**	C	•		C	•			•	•		
Chrome Cover Ring (CCR)**	C	•		C	•			•	•		•
Chrome Bezel with U-Clamp (CBU)			STD			STD				STD	
Chrome Adapter Ring (CAR)		•	•		•	•			•	•	
Glass Lens (GL)*	C	C	•	C	C	•		C	C	C	C
Polycarbonate Lens (LL)*								•	•		
Safety Glass Lens (SG)*								•	•		•
Homalite Lens (HL)*			•			•				•	
Red Set Pointer (SP)**	•	C	C	•	•	C	•	•	•	C	•
Maximum Indicating Pointer (MIP)								C	C	C	
Silicone Dampened Movement (SDM)	C	C	C	C	C	C	C	C	C	C	C
Laser Marking (LM)	•	•	•	•	•	•	•	•	•	•	•
Stainless Steel Tagging (ST)	•	•	•	•	•	•	•	•	•	•	•
Orifice - Brass Press Fit Sintered (20 Micron) (CPO)	•	•	•	•	•	•	•	•	•	•	•
Orifice - Brass Press Fit - 0.1 mm (BP1)	•	•	•	•	•	•	•	•	•	•	•
Orifice - Brass Press Fit - 0.3 mm (BP3)	•	•	•	•	•	•	•	•	•	•	•
Orifice - Brass Press Fit - 0.8 mm (BP8)	•	•	•	•	•	•	•	•	•	•	•

STANDARD ORIFICE FOR 100 SERIES GAUGE IS 0.3 MM PRESS FIT, UNLESS OTHERWISE SPECIFIED.



* A steel, stainless or chrome case & cover ring must be additionally ordered when lenses other than acrylic are utilized on all 100 Series.

** Only 110 Series require a steel, stainless or chrome case & cover ring to be additionally ordered when utilizing a set pointer or cover ring. Please consult factory when a set pointer is to be utilized on a 120 Series.

Consult factory for additional non-stock and special accessory availability.

200 SERIES LOW PRESSURE DIAPHRAGM GAUGE ACCESSORIES

- = Option/accessory is available
- C = Consult factory for availability
- STD = Standard stock series specification

SERIES NO.	25-200	25-210	25-224	40-200
CONNECTION				
Black Rear Flange (BLRF)	●	C		
304SS Rear Flange (SSRF)				●
Black Front Flange (BLFF)	●	●		●
304SS Front Flange (SSFF)				●
Chrome Front Flange (CFF)	●	●		
Stainless Steel Case (SSC)	●	●		STD
Glass Lens (GL)*	●	●		●
Safety Glass Lens (SG)*	●	●		●
Acrylic Lens (PL)	STD	STD		●
Recalibrator Lens (RL)	●	●		
Red Set Pointer (SP)	●	●	●	●
Maximum Indicating Pointer (MIP)	●	●	●	C
SS Bezel w/U-Clamp (SSBU)		●		
Black Bezel w/U-Clamp (BBU)		●		
Black Cover Ring (BCR)	●	●		
Stainless Steel Cover Ring (SSCR)	●	●		STD
Chrome Cover Ring (CCR)	●	●		
Laser Marking (LM)	●	●	●	●
Stainless Steel Tagging (ST)	●	●	●	●
Orifice - Brass Press Fit - 0.3 mm (BP3)		●	●	●
Orifice - Brass Threaded - 0.3 mm (BT3)	●	●	●	●



STANDARD ORIFICE FOR 200 SERIES GAUGE IS 0.3 MM PRESS FIT, UNLESS OTHERWISE SPECIFIED.

* A steel, stainless or chrome cover ring must be additionally ordered when lenses other than acrylic are utilized on all 2-1/2" 200 Series.

Consult factory for additional non-stock and special accessory availability.

300 SERIES BRASS CASE LIQUID-FILLED GAUGE ACCESSORIES

- = Option/accessory is available

SERIES NO.	25-300	25-310	40-300	40-310
CONNECTION				
Chrome Front Flange (CFF)	●	●	●	●
Chrome Front Flange (CFFN) w/o Holes	●	●	●	●
Brass Front Flange (BFF)	●	●	●	●
Black Front Flange (BLFF)			●	●
304SS Rear Flange (SSRF)			●	●
Rear Flange (RF)	●	●		
Chrome Cover Ring (CCR)	●	●	●	
Chrome Bezel with U-Clamp (CBU)		●		●
Maximum Indicating Pointer (MIP)	●	●		
Polycarbonate Lens (LL)			●	●
Glass Lens Overlay (GLO)	●	●		
Safety Glass Overlay (SGO)	●	●	●	●
Adapter Ring (AR)		●		●
7/16" - 20 Straight Thread (SST)*	●	●	●	●
Laser Marking (LM)	●	●	●	●
Stainless Steel Tagging (ST)	●	●	●	●
Orifice - Brass Threaded - 0.3 mm (BT3)	●	●	●	●
Orifice - Brass Threaded - 0.4 mm (BT4)	●	●	●	●
Orifice - Brass Threaded - 0.8 mm (BT8)	●	●	●	●

STANDARD ORIFICE FOR 300 SERIES GAUGE IS 0.8 MM THREADED, UNLESS OTHERWISE SPECIFIED.









* Includes FKM o-ring. Consult factory for availability.

Consult factory for additional non-stock and special accessory availability.

Options & Accessories by Gauge Series





400/500 SERIES ALL STAINLESS STEEL PRESSURE GAUGES DRY, LIQUID & AMMONIA GAUGE ACCESSORIES

- = Option/accessory is available
- C = Consult factory for availability
- STD = Standard stock series specification

SERIES NO.	15-401	15-411	25-400	25-410	40-400	40-410	60-400	60-410
			25-500	25-510	40-500	40-510	60-500	60-510
CONNECTION								
304 SS Front Flange (SSFF)				•	•	•	•	•
304 SS Rear Flange (SSRF)			C	C	•	•	•	•
SS Bezel w/U-Clamp (SSBU)						•		•
Installed 304SS Panel Mount Clamp (SPMC)				•				
Uninstalled 304SS Panel Mount Clamp (25-459-1-SS-PMC)				•				
Installed Steel Panel Mount Clamp (PMC)				•				
Uninstalled Steel Panel Mount Clamp (25-459-1-PMC)				•				
Flange Ring (FR)				•				
Flange Ring 304SS (SSFR)				•				
Adjustable Pointer (AP)					•	•	STD	STD
Safety Glass Lens (SG)			•	•	•	•	STD	STD
Maximum Indicating Pointer (MIP)			•	•	•	•	•	•
Red Set Pointer (SP)			•	•	•	•	•	•
Laser Marking (LM)	•	•	•	•	•	•	•	•
Stainless Steel Tagging (ST)	•	•	•	•	•	•	•	•
Orifice - 316SS Threaded Orifice - 0.8 mm (ST8)	•	•	•	•	•	•	•	•
Orifice - 316SS Threaded Orifice - 0.5 mm (ST5)	•	•	•	•	•	•	•	•

STANDARD ORIFICE FOR 400/500 SERIES GAUGE IS 0.8 MM THREADED, UNLESS OTHERWISE SPECIFIED.
Consult factory for additional non-stock and special accessory availability.

600/700 SERIES PROCESS GAUGE ACCESSORIES

SERIES NO.	DRY		LIQUID FILLED	
	45-640	45-740	45-660	45-760
CONNECTION				
Safety Glass Lens (SG)	•	•	•	•
Glass Lens (GL)	•	•	•	•
Maximum Indicating Pointer (MIP)	•	•	•	•
Uninstalled Black Panel Mount Ring (BPMR)	•	•	•	•
Uninstalled Chrome Panel Mount Ring (CPMR)	•	•	•	•
Overload Stop (OS)	•	•	•	•
Laser Marking (LM)	•	•	•	•
Stainless Steel Tagging (ST)	•	•	•	•
Orifice - Brass Press Fit - 0.3 mm (BP3)	•		•	
Orifice - Brass Threaded - 0.8 mm (BT8)	•		•	
Orifice - 316SS Threaded - 0.8 mm (ST8)		•		•

STANDARD ORIFICE FOR 600/700 SERIES GAUGE IS 0.8 MM THREADED, UNLESS OTHERWISE SPECIFIED.
Consult factory for additional non-stock and special accessory availability.







800 SERIES PRECISION TEST GAUGE ACCESSORIES

SERIES NO.	60-800
CONNECTION	
304 SS Front Flange (SSFF)	•
304 SS Rear Flange (SSRF)	•
Carrying Case (GC)	•
Laser Marking (LM)	•
Stainless Steel Tagging (ST)	•
Orifice - Brass Press Fit - 0.3 mm (BP3)	•
Orifice - Brass Threaded - 0.8 mm (BT8)	•

STANDARD ORIFICE FOR 800 SERIES GAUGE IS 0.8 MM THREADED, UNLESS OTHERWISE SPECIFIED.
Consult factory for additional non-stock and special accessory availability.

900 SERIES ABS & STAINLESS STEEL LIQUID FILLED PRESSURE GAUGE ACCESSORIES

- = Option/accessory is available
- C = Consult factory for availability
- STD = Standard stock series specification

SERIES NO.	15-910	25-900	25-910	25-901	25-911	40-901	40-911
CONNECTION							
Chrome Flange Ring (CFR)			●		●		
304 SS Polished Flange Ring (SSFR)			●		●		
Installed 304SS Panel Mount Clamp (SPMC)					●		
Uninstalled 304SS Panel Mount Clamp (25-459-1-55-SPMC)					●		
Installed Steel Panel Mount Clamp (PMC)			●		●		
Uninstalled Steel Panel Mount Clamp (25-459-1-PMC)			●		●		
SS Bezel with U-Clamp (SSBU)							●
Adjustable Pointer (AP)						●	●
Safety Glass Lens (SG)				●	●	●	●
Black Front Flange (BLFF)			●				
304 SS Front Flange (SSFF)					●	●	●
304 SS Rear Flange (SSRF)				C	C	●	●
Maximum Indicating Pointer (MIP)				●**	●**	●	●
Red Set Pointer (SP)				●	●	●	●
SAE J1926-3:7/16 - 20 Adjustable Connection* (SST)		●	●	●	●	●	●
Laser Marking (LM)	●	●	●	●	●	●	●
Stainless Steel Tagging (ST)	●	●	●	●	●	●	●
Orifice - Brass Press Fit - 0.3 mm (BP3)	●	●	●	●	●	●	●
Orifice - Brass Threaded - 0.5 mm (BT5)	●	●	●	●	●		
Orifice - Brass Threaded - 0.8 mm (BT8)						●	●

STANDARD ORIFICE FOR 900 SERIES GAUGE IS 0.3 MM PRESS FIT, UNLESS OTHERWISE SPECIFIED.

* Includes FKM o-ring. Consult factory for availability.

** For ranges 60 psi and above.

Consult factory for additional non-stock and special accessory availability.

GAUGE FILL OPTIONS

SERIES NO.	VOLUME	SILICONE	HALOCARBON®	-40° SERVICE	MINERAL OIL
300 SERIES	OZ	D.C. 200	4.2 OIL	62:38 GLYCERIN: H2O (d)	LIGHT VISCOSITY
25-300/25-310	2.0	●	●	●	●
40-300/40-310	6.5	●	●	●	●
500 SERIES					
25-500/25-510	2.0	●	●	●	●
40-500/40-510	8.5	●	●	●	●
60-500/60-510	31.0	●	●	●	●
600/700 SERIES					
45-660/45-760	14.0	●	●	●	●
900 SERIES					
25-900/25-910	2.0	C	C	●	C
25-901/25-911	2.0	C	C	●	C
40-901/40-011	8.5	●	●	●	●

Consult factory for -40° Service.

Dial Indicating Gauge Accuracy/Standard Dial Configuration

300 Series Gauges: 4"

Applies to:
400/500 Series Gauges: 4" and 6"

900 Series Gauges: 4"

ACCURACY: $\pm 1.0\%$ full scale											
Primary Scale			Secondary Scales								
Dial Range	Figure	Graduation	kPa	Figure	Graduation	kg/cm ²	Figure	Graduation	bar	Figure	Graduation
-30 inHg to 0 psi	-5 inHg	-0.5 inHg	-100 kPa to 0 kPa	-20 kPa	-2 kPa	-1.02 kg/cm ² to 0 kg/cm ²	-0.2 kg/cm ²	-0.02 kg/cm ²	-1 bar to 0 bar	-0.2 bar	-0.02 bar
-30 inHg to 15 psi	-10 inHg	-1 inHg	-100 kPa to 100 kPa	-50 kPa	-5 kPa	-1 kg/cm ² to 1.05 kg/cm ²	-0.5 kg/cm ²	-0.05 kg/cm ²	-1 bar to 1 bar	-0.5 bar	-0.05 bar
-30 inHg to 30 psi	-10 inHg	-1 inHg	-100 kPa to 205 kPa	-50 kPa	-5 kPa	-1 kg/cm ² to 2.10 kg/cm ²	-0.5 kg/cm ²	-0.1 kg/cm ²	-1 bar to 2.05 bar	-0.5 bar	-0.05 bar
-30 inHg to 60 psi	-30 inHg	-2 inHg	-100 kPa to 410 kPa	-100 kPa	-10 kPa	-1 kg/cm ² to 4.2 kg/cm ²	-1 kg/cm ²	-0.1 kg/cm ²	-1 bar to 4.1 bar	-1 bar	.01 bar
-30 inHg to 100 psi	-30 inHg	-5 inHg	-100 kPa to 680 kPa	-100 kPa	-20 kPa	-1 kg/cm ² to 7 kg/cm ²	-1 kg/cm ²	-0.2 kg/cm ²	-1 bar to 6.8 bar	-1 bar	-0.2 bar
-30 inHg to 160 psi	-30 inHg	-5 inHg	-100 kPa to 1,100 kPa	-100 kPa	-20 kPa	-1 kg/cm ² to 11.2 kg/cm ²	-1 kg/cm ²	-0.2 kg/cm ²	-1 bar to 11 bar	-1 bar	-0.2 bar
-30 inHg to 200 psi	-30 inHg	-5 inHg	-100 kPa to 1,360 kPa	-100 kPa	-20 kPa	-1 kg/cm ² to 14 kg/cm ²	-1 kg/cm ²	-0.2 kg/cm ²	-1 bar to 13.6 bar	-1 bar	-0.2 bar
-30 inHg to 300 psi	-30 inHg	-10 inHg	-100 kPa to 2,050 kPa	-100 kPa	-50 kPa	-1 kg/cm ² to 21 kg/cm ²	-1 kg/cm ²	-0.5 kg/cm ²	-1 bar to 20.5 bar	-1 bar	-0.5 bar
0 psi to 15 psi	3 psi	0.2 psi	0 kPa to 102 kPa	30 kPa	2 kPa	0 kg/cm ² to 1.04 kg/cm ²	0.3 kg/cm ²	0.04 kg/cm ²	0 bar to 1.02 bar	0.3 bar	0.02 bar
0 psi to 30 psi	5 psi	0.5 psi	0 kPa to 205 kPa	50 kPa	5 kPa	0 kg/cm ² to 2.1 kg/cm ²	0.5 kg/cm ²	0.1 kg/cm ²	0 bar to 2.05 bar	0.5 bar	0.05 bar
0 psi to 60 psi	10 psi	1 psi	0 kPa to 410 kPa	100 kPa	10 kPa	0 kg/cm ² to 4.2 kg/cm ²	1 kg/cm ²	0.1 kg/cm ²	0 bar to 4.1 bar	1 bar	0.1 bar
0 psi to 100 psi	20 psi	2 psi	0 kPa to 680 kPa	200 kPa	20 kPa	0 kg/cm ² to 7 kg/cm ²	2 kg/cm ²	0.2 kg/cm ²	0 bar to 6.8 bar	2 bar	0.2 bar
0 psi to 160 psi	20 psi	2 psi	0 kPa to 1,100 kPa	200 kPa	20 kPa	0 kg/cm ² to 11.2 kg/cm ²	2 kg/cm ²	0.2 kg/cm ²	0 bar to 11 bar	2 bar	0.2 bar
0 psi to 200 psi	40 psi	4 psi	0 kPa to 1,360 kPa	400 kPa	40 kPa	0 kg/cm ² to 14 kg/cm ²	4 kg/cm ²	0.4 kg/cm ²	0 bar to 13.6 bar	4 bar	0.4 bar
0 psi to 300 psi	50 psi	5 psi	0 kPa to 2,050 kPa	500 kPa	50 kPa	0 kg/cm ² to 21 kg/cm ²	5 kg/cm ²	0.5 kg/cm ²	0 bar to 20.5 bar	5 bar	0.5 bar
0 psi to 400 psi	50 psi	5 psi	0 kPa to 2,750 kPa	500 kPa	50 kPa	0 kg/cm ² to 28 kg/cm ²	5 kg/cm ²	0.5 kg/cm ²	0 bar to 27.5 bar	5 bar	0.5 bar
0 psi to 600 psi	100 psi	10 psi	0 kPa to 4,100 kPa	1,000 kPa	100 kPa	0 kg/cm ² to 42 kg/cm ²	10 kg/cm ²	1 kg/cm ²	0 bar to 41 bar	10 bar	1 bar
0 psi to 1,000 psi	200 psi	20 psi	0 kPa to 6,800 kPa	2,000 kPa	200 kPa	0 kg/cm ² to 70 kg/cm ²	20 kg/cm ²	2 kg/cm ²	0 bar to 68 bar	20 bar	2 bar
0 psi to 1,500 psi	300 psi	20 psi	0 kPa to 10,200 kPa	3,000 kPa	200 kPa	0 kg/cm ² to 104 kg/cm ²	30 kg/cm ²	2 kg/cm ²	0 bar to 102 bar	30 bar	2 bar
0 psi to 2,000 psi	400 psi	40 psi	0 kPa to 13,600 kPa	4,000 kPa	400 kPa	0 kg/cm ² to 140 kg/cm ²	40 kg/cm ²	4 kg/cm ²	0 bar to 136 bar	40 bar	4 bar
0 psi to 3,000 psi	500 psi	50 psi	0 kPa to 20,500 kPa	5,000 kPa	500 kPa	0 kg/cm ² to 210 kg/cm ²	50 kg/cm ²	5 kg/cm ²	0 bar to 205 bar	50 bar	5 bar
0 psi to 5,000 psi	1,000 psi	100 psi	0 kPa to 34,000 kPa	10,000 kPa	1,000 kPa	0 kg/cm ² to 350 kg/cm ²	100 kg/cm ²	10 kg/cm ²	0 bar to 340 bar	100 bar	10 bar
0 psi to 6,000 psi	1,000 psi	100 psi	0 kPa to 41,000 kPa	10,000 kPa	1,000 kPa	0 kg/cm ² to 420 kg/cm ²	100 kg/cm ²	10 kg/cm ²	0 bar to 410 bar	100 bar	10 bar
0 psi to 7,500 psi	1,500 psi	100 psi	0 kPa to 51,000 kPa	10,000 kPa	1,000 kPa	0 kg/cm ² to 520 kg/cm ²	100 kg/cm ²	10 kg/cm ²	0 bar to 510 bar	100 bar	10 bar
0 psi to 10,000 psi	2,000 psi	200 psi	0 kPa to 68,000 kPa	20,000 kPa	2,000 kPa	0 kg/cm ² to 700 kg/cm ²	200 kg/cm ²	20 kg/cm ²	0 bar to 680 bar	200 bar	20 bar
0 psi to 15,000 psi	3,000 psi	200 psi	0 kPa to 102,000 kPa	30,000 kPa	2,000 kPa	0 kg/cm ² to 1,040 kg/cm ²	300 kg/cm ²	20 kg/cm ²	0 bar to 1,030 bar	300 bar	20 bar
0 psi to 20,000 psi	4,000 psi	400 psi	0 kPa to 136,000 kPa	40,000 kPa	4,000 kPa	0 kg/cm ² to 1,400 kg/cm ²	400 kg/cm ²	40 kg/cm ²	0 bar to 1,360 bar	400 bar	40 bar
0 psi to 30,000 psi	5,000 psi	500 psi	0 kPa to 205,000 kPa	50,000 kPa	5,000 kPa	0 kg/cm ² to 2,100 kg/cm ²	500 kg/cm ²	50 kg/cm ²	0 bar to 2,050 bar	500 bar	50 bar
0 psi to 40,000 psi	5,000 psi	500 psi	0 kPa to 275,000 kPa	50,000 kPa	5,000 kPa	0 kg/cm ² to 2,800 kg/cm ²	500 kg/cm ²	50 kg/cm ²	0 bar to 2,750 bar	500 bar	50 bar
0 psi to 50,000 psi	10,000 psi	1000 psi	0 kPa to 340,000 kPa	100,000 kPa	10,000 kPa	0 kg/cm ² to 3,500 kg/cm ²	1,000 kg/cm ²	100 kg/cm ²	0 bar to 3,400 bar	1,000 bar	100 bar
0 psi to 60,000 psi	10,000 psi	1000 psi	0 kPa to 410,000 kPa	100,000 kPa	10,000 kPa	0 kg/cm ² to 4,200 kg/cm ²	1,000 kg/cm ²	100 kg/cm ²	0 bar to 4,100 bar	1,000 bar	100 bar
0 psi to 75,000 psi	15,000 psi	1000 psi	0 kPa to 510,000 kPa	100,000 kPa	10,000 kPa	0 kg/cm ² to 5,200 kg/cm ²	1,000 kg/cm ²	100 kg/cm ²	0 bar to 5,100 bar	1,000 bar	100 bar
0 psi to 100,000 psi	20,000 psi	2000 psi	0 kPa to 680,000 kPa	200,000 kPa	20,000 kPa	0 kg/cm ² to 7,000 kg/cm ²	2,000 kg/cm ²	200 kg/cm ²	0 bar to 6,800 bar	2,000 bar	200 bar

Dial Indicating Gauge Accuracy/Standard Dial Configuration

Applies to:

200 Series Gauges: 2-1/2" and 4"

700 Series Gauges (Low Pressure): 4-1/2"

ACCURACY: $\pm 1.0\%$ full scale					
Standard Dial Configurations					
Dial Range	Figure Interval	Graduation Intervals	Dial Range	Figure Interval	Graduation Intervals
-15 inH ₂ O to 0 inH ₂ O	-3 inH ₂ O	-0.2 inH ₂ O	0 oz/in ² to 10 oz/in ²	2 oz/in ²	0.2 oz/in ²
-30 inH ₂ O to 0 inH ₂ O	-5 inH ₂ O	-0.5 inH ₂ O	0 oz/in ² to 15 oz/in ²	3 oz/in ²	0.2 oz/in ²
-60 inH ₂ O to 0 inH ₂ O	-10 inH ₂ O	-1 inH ₂ O	0 oz/in ² to 30 oz/in ²	5 oz/in ²	0.5 oz/in ²
-100 inH ₂ O to 0 inH ₂ O	-20 inH ₂ O	-2 inH ₂ O	0 oz/in ² to 35 oz/in ²	5 oz/in ²	0.5 oz/in ²
-60 inH ₂ O to 60 inH ₂ O	-10 inH ₂ O 10 inH ₂ O	-1 inH ₂ O 1 inH ₂ O	0 oz/in ² to 60 oz/in ²	10 oz/in ²	1 oz/in ²
0 inH ₂ O to 10 inH ₂ O	2 inH ₂ O	0.2 inH ₂ O	0 oz/in ² to 100 oz/in ²	20 oz/in ²	2 oz/in ²
0 inH ₂ O to 15 inH ₂ O	3 inH ₂ O	0.2 inH ₂ O	0 oz/in ² to 160 oz/in ² **	40 oz/in ²	4 oz/in ²
0 inH ₂ O to 30 inH ₂ O	5 inH ₂ O	0.5 inH ₂ O	0 oz/in ² inH ₂ O to 20 oz/in ² inH ₂ O	4 oz/in ² - 10 inH ₂ O	0.4 oz/in ² - 1 inH ₂ O
0 inH ₂ O to 60 inH ₂ O	10 inH ₂ O	1 inH ₂ O	0 oz/in ² inH ₂ O to 32 oz/in ² inH ₂ O	4 oz/in ² - 10 inH ₂ O	0.5 oz/in ² - 1 inH ₂ O
0 inH ₂ O to 100 inH ₂ O	20 inH ₂ O	2 inH ₂ O	0 psi to 3 psi	0.5 psi	0.05 psi
0 inH ₂ O to 160 inH ₂ O*	40 inH ₂ O	4 inH ₂ O	0 psi to 5 psi	1 psi	0.1 psi
0 inH ₂ O to 200 inH ₂ O	40 inH ₂ O	4 inH ₂ O	0 psi to 10 psi	2 psi	0.2 psi

* The values in the table are for 2-1/2". On 4" & 4-1/2" 0 inH₂O to 160 inH₂O gauges, the Figure is 20 inH₂O, and the Graduation is 2 inH₂O.

** The values in the table are for 2-1/2". On 4" & 4-1/2" 0 oz/in² to 160 oz/in² gauges, the Figure is 20 oz/in², and the Graduation is 2 oz/in².

Dial Indicating Gauge Accuracy/Standard Dial Configuration

Applies to:

100 Series Gauges: 4"

300 Series Gauges: 2-1/2"

400/500 Series Gauges: 2-1/2"

900 Series Gauges: 2-1/2"

ACCURACY: ±1.6% full scale											
Primary Scale			Secondary Scales								
Dial Range	Figure	Graduation	kPa	Figure	Graduation	kg/cm ²	Figure	Graduation	bar	Figure	Graduation
-30 inHg to 0 psi	-5 inHg	-0.5 inHg	-100 kPa to 0 kPa	-20 kPa	-2 kPa	-1.02 kg/cm ² to 0 kg/cm ²	-0.2 kg/cm ²	-0.02 kg/cm ²	-1 bar to 0 bar	-0.2 bar	-0.02 bar
-30 inHg to 15 psi	-10 inHg 5 psi	-1 inHg 0.5 psi	-100 kPa to 100 kPa	-50 kPa 50 kPa	-5 kPa 5 kPa	-1 kg/cm ² to 1.05 kg/cm ²	-0.5 kg/cm ² 0.5 kg/cm ²	-0.05 kg/cm ² 0.05 kg/cm ²	-1 bar to 1 bar	-0.5 bar 0.5 bar	-0.05 bar 0.05 bar
-30 inHg to 30 psi	-30 inHg 10 psi	-2 inHg 1 psi	-100 kPa to 205 kPa	-100 kPa 100 kPa	-10 kPa 10 kPa	-1 kg/cm ² to 2.10 kg/cm ²	-1 kg/cm ² 1 kg/cm ²	-0.1 kg/cm ² 0.1 kg/cm ²	-1 bar to 2 bar	-1 bar 1 bar	-0.1 bar 0.1 bar
-30 inHg to 60 psi	-30 inHg 20 psi	-5 inHg 2 psi	-100 kPa to 400 kPa	-100 kPa 200 kPa	-20 kPa 20 kPa	-1 kg/cm ² to 4.2 kg/cm ²	-1 kg/cm ² 2 kg/cm ²	-2 kg/cm ² 0.2 kg/cm ²	-1 bar to 4 bar	-1 bar 2 bar	-0.2 bar 0.2 bar
-30 inHg to 100 psi	-30 inHg 20 psi	-5 inHg 2 psi	-100 kPa to 680 kPa	-100 kPa 200 kPa	-20 kPa 20 kPa	-1 kg/cm ² to 7 kg/cm ²	-1 kg/cm ² 2 kg/cm ²	-0.2 kg/cm ² 0.2 kg/cm ²	-1 bar to 6.8 bar	-1 bar 2 bar	-0.2 bar 0.2 bar
-30 inHg to 160 psi	-30 inHg 40 psi	-10 inHg 4 psi	-100 kPa to 1,080 kPa	-100 kPa 400 kPa	-50 kPa 40 kPa	-1 kg/cm ² to 11.2 kg/cm ²	-1 kg/cm ² 4 kg/cm ²	-0.5 kg/cm ² 0.4 kg/cm ²	-1 bar to 11 bar	-1 bar 4 bar	-0.5 bar 0.4 bar
-30 inHg to 200 psi	-30 inHg 40 psi	-10 inHg 4 psi	-100 kPa to 1,360 kPa	-100 kPa 400 kPa	-50 kPa 40 kPa	-1 kg/cm ² to 14 kg/cm ²	-1 kg/cm ² 4 kg/cm ²	-0.5 kg/cm ² 0.4 kg/cm ²	-1 bar to 13.6 bar	-1 bar 4 bar	-0.5 bar 0.4 bar
-30 inHg to 300 psi	-30 inHg 50 psi	-10 inHg 5 psi	-100 kPa to 2,050 kPa	-100 kPa 500 kPa	-50 kPa 50 kPa	-1 kg/cm ² to 21 kg/cm ²	-1 kg/cm ² 5 kg/cm ²	-0.5 kg/cm ² 0.5 kg/cm ²	-1 bar to 20.5 bar	-1 bar 5 bar	-0.5 bar 0.5 bar
0 psi to 15 psi	3 psi	0.2 psi	0 kPa to 102 kPa	30 kPa	2 kPa	0 kg/cm ² to 1.04 kg/cm ²	0.3 kg/cm ²	0.02 kg/cm ²	0 bar to 1.02 bar	0.3 bar	0.02 bar
0 psi to 30 psi	5 psi	0.5 psi	0 kPa to 205 kPa	50 kPa	5 kPa	0 kg/cm ² to 2.1 kg/cm ²	0.5 kg/cm ²	0.05 kg/cm ²	0 bar to 2.05 bar	0.5 bar	0.05 bar
0 psi to 60 psi	10 psi	1 psi	0 kPa to 410 kPa	100 kPa	10 kPa	0 kg/cm ² to 4.2 kg/cm ²	1 kg/cm ²	0.1 kg/cm ²	0 bar to 4.10 bar	1 bar	0.1 bar
0 psi to 100 psi	20 psi	2 psi	0 kPa to 680 kPa	200 kPa	20 kPa	0 kg/cm ² to 7 kg/cm ²	2 kg/cm ²	0.2 kg/cm ²	0 bar to 6.8 bar	2 bar	0.2 bar
0 psi to 160 psi	40 psi	4 psi	0 kPa to 1,080 kPa	400 kPa	40 kPa	0 kg/cm ² to 11.2 kg/cm ²	4 kg/cm ²	0.4 kg/cm ²	0 bar to 11 bar	4 bar	0.4 bar
0 psi to 200 psi	40 psi	4 psi	0 kPa to 1,360 kPa	400 kPa	40 kPa	0 kg/cm ² to 14 kg/cm ²	4 kg/cm ²	0.4 kg/cm ²	0 bar to 13.6 bar	4 bar	0.4 bar
0 psi to 300 psi	50 psi	5 psi	0 kPa to 2,050 kPa	500 kPa	50 kPa	0 kg/cm ² to 21 kg/cm ²	5 kg/cm ²	0.5 kg/cm ²	0 bar to 20.5 bar	5 bar	0.5 bar
0 psi to 400 psi	100 psi	10 psi	0 kPa to 2,700 kPa	1,000 kPa	100 kPa	0 kg/cm ² to 28 kg/cm ²	10 kg/cm ²	1 kg/cm ²	0 bar to 27 bar	10 bar	1 bar
0 psi to 600 psi	100 psi	10 psi	0 kPa to 4,100 kPa	1,000 kPa	100 kPa	0 kg/cm ² to 42 kg/cm ²	10 kg/cm ²	1 kg/cm ²	0 bar to 41 bar	10 bar	1 bar
0 psi to 1,000 psi	200 psi	20 psi	0 kPa to 6,800 kPa	2,000 kPa	200 kPa	0 kg/cm ² to 70 kg/cm ²	20 kg/cm ²	2 kg/cm ²	0 bar to 68 bar	20 bar	2 bar
0 psi to 1,500 psi	300 psi	20 psi	0 kPa to 10,200 kPa	3,000 kPa	200 kPa	0 kg/cm ² to 104 kg/cm ²	30 kg/cm ²	2 kg/cm ²	0 bar to 102 bar	30 bar	2 bar
0 psi to 2,000 psi	400 psi	40 psi	0 kPa to 13,600 kPa	4,000 kPa	400 kPa	0 kg/cm ² to 140 kg/cm ²	40 kg/cm ²	4 kg/cm ²	0 bar to 136 bar	40 bar	4 bar
0 psi to 3,000 psi	500 psi	50 psi	0 kPa to 20,500 kPa	5,000 kPa	500 kPa	0 kg/cm ² to 210 kg/cm ²	50 kg/cm ²	5 kg/cm ²	0 bar to 205 bar	50 bar	5 bar
0 psi to 5,000 psi	1,000 psi	100 psi	0 kPa to 34,000 kPa	10,000 kPa	1,000 kPa	0 kg/cm ² to 350 kg/cm ²	100 kg/cm ²	10 kg/cm ²	0 bar to 340 bar	100 bar	10 bar
0 psi to 6,000 psi	1,000 psi	100 psi	0 kPa to 41,000 kPa	10,000 kPa	1,000 kPa	0 kg/cm ² to 420 kg/cm ²	100 kg/cm ²	10 kg/cm ²	0 bar to 410 bar	100 bar	10 bar
0 psi to 7,500 psi	1,500 psi	100 psi	0 kPa to 51,000 kPa	10,000 kPa	1,000 kPa	0 kg/cm ² to 520 kg/cm ²	100 kg/cm ²	10 kg/cm ²	0 bar to 510 bar	100 bar	10 bar
0 psi to 10,000 psi	2,000 psi	200 psi	0 kPa to 68,000 kPa	20,000 kPa	2,000 kPa	0 kg/cm ² to 700 kg/cm ²	200 kg/cm ²	20 kg/cm ²	0 bar to 680 bar	200 bar	20 bar
0 psi to 15,000 psi	3,000 psi	200 psi	0 kPa to 102,000 kPa	30,000 kPa	2,000 kPa	0 kg/cm ² to 1,040 kg/cm ²	300 kg/cm ²	20 kg/cm ²	0 bar to 1,020 bar	300 bar	20 bar

Dial Indicating Gauge Accuracy/Standard Dial Configuration

Applies to:
600/700 Series Gauges: 4-1/2"

ACCURACY: $\pm 0.5\%$ full scale

Primary Scale			Secondary Scales								
Dial Range	Figure	Graduation	kPa	Figure	Graduation	kg/cm ²	Figure	Graduation	bar	Figure	Graduation
-30 inHg to 0 psi	-5 inHg	-0.2 inHg	-101 kPa to 0 kPa	-20 kPa	-1 kPa	-1.03 kg/cm ² to 0 kg/cm ²	-0.2 kg/cm ²	-0.01 kg/cm ²	-1.01 bar to 0 bar	-0.2 bar	-0.01 bar
-30 inHg to 15 psi	-5 inHg 3 psi	-0.5 inHg 0.2 psi	-100 kPa to 102 kPa	-20 kPa 20 kPa	-2 kPa 2 kPa	-1 kg/cm ² to 1.04 kg/cm ²	-0.2 kg/cm ² 0.2 kg/cm ²	-0.02 kg/cm ² 0.02 kg/cm ²	-1 bar to 1.02 bar	-0.2 bar 0.2 bar	-0.02 bar 0.02 bar
-30 inHg to 30 psi	-10 inHg 5 psi	-1 inHg 0.5 psi	-100 kPa to 205 kPa	-50 kPa 50 kPa	-5 kPa 5 kPa	-1 kg/cm ² to 2.10 kg/cm ²	-0.5 kg/cm ² 0.5 kg/cm ²	-0.05 kg/cm ² 0.05 kg/cm ²	-1 bar to 2.05 bar	-0.5 bar 0.5 bar	-0.05 bar 0.05 bar
-30 inHg to 60 psi	-10 inHg 10 psi	-1 inHg 0.4 psi	-100 kPa to 412 kPa	-50 kPa 100 kPa	-5 kPa 4 kPa	-1 kg/cm ² to 4.2 kg/cm ²	-0.5 kg/cm ² 1 kg/cm ²	-0.01 kg/cm ² 0.04 kg/cm ²	-1 bar to 4.12 bar	-0.5 bar 1 bar	-0.01 bar 0.04 bar
-30 inHg to 100 psi	-30 inHg 10 psi	-2 inHg 1 psi	-100 kPa to 680 kPa	-100 kPa 100 kPa	-10 kPa 10 kPa	-1 kg/cm ² to 7 kg/cm ²	-1 kg/cm ² 1 kg/cm ²	-0.1 kg/cm ² 0.1 kg/cm ²	-1 bar to 6.8 bar	-1 bar 1 bar	-0.1 bar 0.1 bar
-30 inHg to 160 psi	-30 inHg 20 psi	-5 inHg 2 psi	-100 kPa to 1,100 kPa	-100 kPa 200 kPa	-20 kPa 20 kPa	-1 kg/cm ² to 11.2 kg/cm ²	-1 kg/cm ² 2 kg/cm ²	-0.2 kg/cm ² 0.2 kg/cm ²	-1 bar to 11 bar	-1 bar 2 bar	-0.2 bar 0.2 bar
-30 inHg to 200 psi	-30 inHg 20 psi	-5 inHg 2 psi	-100 kPa to 1,360 kPa	-100 kPa 200 kPa	-20 kPa 20 kPa	-1 kg/cm ² to 14 kg/cm ²	-1 kg/cm ² 2 kg/cm ²	-0.2 kg/cm ² 0.2 kg/cm ²	-1 bar to 13.6 bar	-1 bar 2 bar	-0.2 bar 0.2 bar
0 psi to 15 psi	3 psi	0.1 psi	0 kPa to 103 kPa	30 kPa	1 kPa	0 kg/cm ² to 1.05 kg/cm ²	0.3 kg/cm ²	0.01 kg/cm ²	0 bar to 1.03 bar	0.3 bar	0.01 bar
0 psi to 30 psi	5 psi	0.2 psi	0 kPa to 206 kPa	50 kPa	2 kPa	0 kg/cm ² to 2.1 kg/cm ²	0.5 kg/cm ²	0.02 kg/cm ²	0 bar to 2.06 bar	0.5 bar	0.02 bar
0 psi to 60 psi	10 psi	0.4 psi	0 kPa to 412 kPa	100 kPa	4 kPa	0 kg/cm ² to 4.2 kg/cm ²	1 kg/cm ²	0.04 kg/cm ²	0 bar to 4.12 bar	1 bar	0.04 bar
0 psi to 100 psi	10 psi	1 psi	0 kPa to 680 kPa	100 kPa	10 kPa	0 kg/cm ² to 7 kg/cm ²	1 kg/cm ²	0.1 kg/cm ²	0 bar to 6.8 bar	1 bar	0.1 bar
0 psi to 160 psi	20 psi	1 psi	0 kPa to 1,100 kPa	200 kPa	10 kPa	0 kg/cm ² to 11.2 kg/cm ²	2 kg/cm ²	0.1 kg/cm ²	0 bar to 11 bar	2 bar	0.1 bar
0 psi to 200 psi	20 psi	2 psi	0 kPa to 1,360 kPa	200 kPa	20 kPa	0 kg/cm ² to 14 kg/cm ²	2 kg/cm ²	0.2 kg/cm ²	0 bar to 13.6 bar	2 bar	0.2 bar
0 psi to 300 psi	50 psi	2 psi	0 kPa to 2,060 kPa	500 kPa	20 kPa	0 kg/cm ² to 21 kg/cm ²	5 kg/cm ²	0.2 kg/cm ²	0 bar to 20.6 bar	5 bar	0.2 bar
0 psi to 400 psi	40 psi	4 psi	0 kPa to 2,720 kPa	400 kPa	40 kPa	0 kg/cm ² to 28 kg/cm ²	4 kg/cm ²	0.4 kg/cm ²	0 bar to 27.2 bar	4 bar	0.4 bar
0 psi to 600 psi	100 psi	4 psi	0 kPa to 4,120 kPa	1,000 kPa	40 kPa	0 kg/cm ² to 42 kg/cm ²	10 kg/cm ²	0.4 kg/cm ²	0 bar to 41.2 bar	10 bar	0.4 bar
0 psi to 1,000 psi	100 psi	10 psi	0 kPa to 6,800 kPa	1,000 kPa	100 kPa	0 kg/cm ² to 70 kg/cm ²	10 kg/cm ²	1 kg/cm ²	0 bar to 68 bar	10 bar	1 bar
0 psi to 1,500 psi	300 psi	10 psi	0 kPa to 10,300 kPa	3,000 kPa	100 kPa	0 kg/cm ² to 105 kg/cm ²	30 kg/cm ²	1 kg/cm ²	0 bar to 103 bar	30 bar	1 bar
0 psi to 2,000 psi	200 psi	20 psi	0 kPa to 13,600 kPa	2,000 kPa	200 kPa	0 kg/cm ² to 140 kg/cm ²	20 kg/cm ²	2 kg/cm ²	0 bar to 136 bar	20 bar	2 bar
0 psi to 3,000 psi	500 psi	20 psi	0 kPa to 20,600 kPa	5,000 kPa	200 kPa	0 kg/cm ² to 210 kg/cm ²	50 kg/cm ²	2 kg/cm ²	0 bar to 206 bar	50 bar	2 bar
0 psi to 5,000 psi	500 psi	50 psi	0 kPa to 34,000 kPa	5,000 kPa	500 kPa	0 kg/cm ² to 350 kg/cm ²	50 kg/cm ²	5 kg/cm ²	0 bar to 340 bar	50 bar	5 bar
0 psi to 6,000 psi	1,000 psi	40 psi	0 kPa to 41,200 kPa	10,000 kPa	400 kPa	0 kg/cm ² to 420 kg/cm ²	100 kg/cm ²	4 kg/cm ²	0 bar to 412 bar	100 bar	4 bar
0 psi to 10,000 psi	1,000 psi	100 psi	0 kPa to 68,000 kPa	10,000 kPa	1,000 kPa	0 kg/cm ² to 700 kg/cm ²	100 kg/cm ²	10 kg/cm ²	0 bar to 680 bar	100 bar	10 bar
0 psi to 15,000 psi	3,000 psi	100 psi	0 kPa to 103,000 kPa	30,000 kPa	1,000 kPa	0 kg/cm ² to 1,050 kg/cm ²	300 kg/cm ²	10 kg/cm ²	0 bar to 1,030 bar	300 bar	10 bar
0 psi to 20,000 psi	2,000 psi	200 psi	0 kPa to 136,000 kPa	20,000 kPa	2,000 kPa	0 kg/cm ² to 1,400 kg/cm ²	200 kg/cm ²	20 kg/cm ²	0 bar to 1,360 bar	200 bar	20 bar
0 psi to 30,000 psi	5,000 psi	200 psi	0 kPa to 206,000 kPa	50,000 kPa	2,000 kPa	0 kg/cm ² to 2,100 kg/cm ²	500 kg/cm ²	20 kg/cm ²	0 bar to 2,060 bar	500 bar	20 bar
0 psi to 40,000 psi	4,000 psi	400 psi	0 kPa to 272,000 kPa	40,000 kPa	4,000 kPa	0 kg/cm ² to 2,800 kg/cm ²	400 kg/cm ²	40 kg/cm ²	0 bar to 2,720 bar	400 bar	40 bar
0 psi to 50,000 psi	5,000 psi	500 psi	0 kPa to 340,000 kPa	50,000 kPa	5,000 kPa	0 kg/cm ² to 3,500 kg/cm ²	500 kg/cm ²	50 kg/cm ²	0 bar to 3,400 bar	500 bar	50 bar
0 psi to 60,000 psi	10,000 psi	400 psi	0 kPa to 412,000 kPa	100,000 kPa	4,000 kPa	0 kg/cm ² to 4,200 kg/cm ²	1,000 kg/cm ²	40 kg/cm ²	0 bar to 4,120 bar	1,000 bar	40 bar

Dial Indicating Gauge Accuracy/Standard Dial Configuration

100 Series Gauges: 1-1/2", 2" and 2-1/2"

Applies to:
400 Series Gauges: 1-1/2"

900 Series Gauges: 1-1/2" and 2"

ACCURACY: $\pm 2.5\%$ full scale											
Primary Scale			Secondary Scales								
Dial Range	Figure	Graduation	kPa	Figure	Graduation	kg/cm ²	Figure	Graduation	bar	Figure	Graduation
-30 inHg to 0 psi	-5 inHg	-0.5 inHg	-100 kPa to 0 kPa	-20 kPa	-5 kPa	-1 kg/cm ² to 0 kg/cm ²	-0.2 kg/cm ²	-0.05 kg/cm ²	-1 bar to 0 bar	-0.2 bar	-0.05 bar
-30 inHg to 15 psi	-10 inHg 5 psi	-1 inHg 0.5 psi	-100 kPa to 100 kPa	-50 kPa 50 kPa	-5 kPa 5 kPa	-1 kg/cm ² to 1.05 kg/cm ²	-0.5 kg/cm ² 0.5 kg/cm ²	-0.05 kg/cm ² 0.05 kg/cm ²	-1 bar to 1 bar	-0.5 bar 0.5 bar	-0.05 bar 0.05 bar
-30 inHg to 30 psi	-30 inHg 10 psi	-2 inHg 1 psi	-100 kPa to 200 kPa	-100 kPa 100 kPa	-10 kPa 10 kPa	-1 kg/cm ² to 2.10 kg/cm ²	-1 kg/cm ² 1 kg/cm ²	-0.1 kg/cm ² 0.1 kg/cm ²	-1 bar to 2 bar	-1 bar 1 bar	-0.1 bar 0.1 bar
-30 inHg to 60 psi	-30 inHg 20 psi	-5 inHg 2 psi	-100 kPa to 400 kPa	-100 kPa 200 kPa	-20 kPa 20 kPa	-1 kg/cm ² to 4.2 kg/cm ²	-1 kg/cm ² 2 kg/cm ²	-0.2 kg/cm ² 0.2 kg/cm ²	-1 bar to 4 bar	-1 bar 2 bar	-0.2 bar 0.2 bar
-30 inHg to 100 psi	-30 inHg 20 psi	-10 inHg 5 psi	-100 kPa to 680 kPa	-100 kPa 200 kPa	-50 kPa 50 kPa	-1 kg/cm ² to 7 kg/cm ²	-1 kg/cm ² 2 kg/cm ²	-0.5 kg/cm ² 0.5 kg/cm ²	-1 bar to 6.8 bar	-1 bar 2 bar	-0.5 bar 0.5 bar
-30 inHg to 160 psi	-30 inHg 40 psi	-10 inHg 4 psi	-100 kPa to 1,100 kPa	-100 kPa 400 kPa	-50 kPa 40 kPa	-1 kg/cm ² to 11.2 kg/cm ²	-1 kg/cm ² 4 kg/cm ²	-0.5 kg/cm ² 0.4 kg/cm ²	-1 bar to 11 bar	-1 bar 4 bar	-0.5 bar 0.4 bar
-30 inHg to 200 psi	-30 inHg 40 psi	-10 inHg 4 psi	-100 kPa to 1,360 kPa	-100 kPa 400 kPa	-50 kPa 40 kPa	-1 kg/cm ² to 14 kg/cm ²	-1 kg/cm ² 4 kg/cm ²	-0.5 kg/cm ² 0.4 kg/cm ²	-1 bar to 13.6 bar	-1 bar 4 bar	-0.5 bar 0.4 bar
-30 inHg to 300 psi	-30 inHg 100 psi	-30 inHg 10 psi	-100 kPa to 2,050 kPa	-100 kPa 1,000 kPa	-100 kPa 100 kPa	-1 kg/cm ² to 21 kg/cm ²	-1 kg/cm ² 10 kg/cm ²	-1 kg/cm ² 1 kg/cm ²	-1 bar to 20.5 bar	-1 bar 10 bar	-1 bar 1 bar
0 psi to 15 psi	3 psi	0.5 psi	0 kPa to 100 kPa	30 kPa	5 kPa	0 kg/cm ² to 1.05 kg/cm ²	0.3 kg/cm ²	0.05 kg/cm ²	0 bar to 1 bar	0.3 bar	0.05 bar
0 psi to 30 psi	5 psi	0.5 psi	0 kPa to 205 kPa	50 kPa	5 kPa	0 kg/cm ² to 2.1 kg/cm ²	0.5 kg/cm ²	0.05 kg/cm ²	0 bar to 2.05 bar	0.5 bar	0.05 bar
0 psi to 60 psi	10 psi	1 psi	0 kPa to 410 kPa	100 kPa	10 kPa	0 kg/cm ² to 4.2 kg/cm ²	1 kg/cm ²	0.1 kg/cm ²	0 bar to 4.1 bar	1 bar	0.1 bar
0 psi to 100 psi	20 psi	2 psi	0 kPa to 680 kPa	200 kPa	20 kPa	0 kg/cm ² to 7 kg/cm ²	2 kg/cm ²	0.2 kg/cm ²	0 bar to 6.8 bar	2 bar	0.2 bar
0 psi to 160 psi	40 psi	4 psi	0 kPa to 1,100 kPa	400 kPa	40 kPa	0 kg/cm ² to 11.2 kg/cm ²	4 kg/cm ²	0.4 kg/cm ²	0 bar to 11 bar	4 bar	0.4 bar
0 psi to 200 psi	40 psi	4 psi	0 kPa to 1,360 kPa	400 kPa	40 kPa	0 kg/cm ² to 14 kg/cm ²	4 kg/cm ²	0.4 kg/cm ²	0 bar to 13.6 bar	4 bar	0.4 bar
0 psi to 300 psi	50 psi	5 psi	0 kPa to 2,050 kPa	500 kPa	50 kPa	0 kg/cm ² to 21 kg/cm ²	5 kg/cm ²	0.5 kg/cm ²	0 bar to 20.5 bar	5 bar	0.5 bar
0 psi to 400 psi	100 psi	10 psi	0 kPa to 2,700 kPa	1,000 kPa	100 kPa	0 kg/cm ² to 28 kg/cm ²	10 kg/cm ²	1 kg/cm ²	0 bar to 27 bar	10 bar	1 bar
0 psi to 600 psi	100 psi	10 psi	0 kPa to 4,100 kPa	1,000 kPa	100 kPa	0 kg/cm ² to 42 kg/cm ²	10 kg/cm ²	1 kg/cm ²	0 bar to 41 bar	10 bar	1 bar
0 psi to 1,000 psi	200 psi	20 psi	0 kPa to 6,800 kPa	2,000 kPa	200 kPa	0 kg/cm ² to 70 kg/cm ²	20 kg/cm ²	2 kg/cm ²	0 bar to 68 bar	20 bar	2 bar
0 psi to 1,500 psi	300 psi	50 psi	0 kPa to 10,000 kPa	3,000 kPa	500 kPa	0 kg/cm ² to 105 kg/cm ²	30 kg/cm ²	5 kg/cm ²	0 bar to 100 bar	30 bar	5 bar
0 psi to 2,000 psi	400 psi	40 psi	0 kPa to 13,600 kPa	4,000 kPa	400 kPa	0 kg/cm ² to 140 kg/cm ²	40 kg/cm ²	4 kg/cm ²	0 bar to 136 bar	40 bar	4 bar
0 psi to 3,000 psi	500 psi	50 psi	0 kPa to 20,500 kPa	5,000 kPa	500 kPa	0 kg/cm ² to 210 kg/cm ²	50 kg/cm ²	5 kg/cm ²	0 bar to 205 bar	50 bar	5 bar
0 psi to 5,000 psi	1000 psi	100 psi	0 kPa to 34,000 kPa	10,000 kPa	1,000 kPa	0 kg/cm ² to 350 kg/cm ²	100 kg/cm ²	10 kg/cm ²	0 bar to 340 bar	100 bar	10 bar
0 psi to 6,000 psi	1000 psi	100 psi	0 kPa to 41,000 kPa	10,000 kPa	1,000 kPa	0 kg/cm ² to 420 kg/cm ²	100 kg/cm ²	10 kg/cm ²	0 bar to 410 bar	100 bar	10 bar

Dial Indicating Gauge Accuracy/Standard Dial Configuration

Applies to:
800 Series Gauges

ACCURACY: ±0.25% full scale					
Primary Scale			Primary Scale		
Dial Range	Figure	Graduation	Dial Range	Figure	Graduation
0 psi to 30 psi	2 psi	0.1 psi	0 psi to 1,500 psi	100 psi	5 psi
0 psi to 60 psi	5 psi	0.2 psi	0 psi to 2,000 psi	200 psi	10 psi
0 psi to 100 psi	10 psi	0.5 psi	0 psi to 3,000 psi	250 psi	10 psi
0 psi to 160 psi	20 psi	0.8 psi	0 psi to 5,000 psi	500 psi	20 psi
0 psi to 200 psi	20 psi	1 psi	0 psi to 6,000 psi	500 psi	20 psi
0 psi to 300 psi	25 psi	1 psi			
0 psi to 400 psi	50 psi	2 psi			
0 psi to 600 psi	50 psi	2 psi			
0 psi to 1,000 psi	100 psi	5 psi			

PRESSURE & VACUUM CONVERSIONS

Pounds per Square Inch	bar	Kilopascals	Kilograms per Square Centimeter	Ounces per Square Inch	Inches of Mercury	Millimeters of Mercury	Inches of Water
psi	bar	kPa	kg/cm ²	oz-in ²	inHg	mmHg*	inH ₂ O
1	.0689476	6.89476	.0703069	16	2.03602	51.71485	27.6807
14.5038	1	100	1.019716	232.0608	29.530	750.0626	401.8596
.145038	.01	1	.0101972	2.320608	.295299	7.500610	401.8596
14.2233	.9806649	98.06649	1	227.5739	28.95901	735.5588	393.7118
.0625	.0043092	.4309223	.0043942	1	.1272513	3.23218	1.73004
.4911542	.0338639	3.386389	.0345316	7.85847	1	25.4	13.59548
.0193368	.0013332	.1333225	.0013595	.3093888	.0393701	1	.535255
.0361263	.0024908	.2490819	.0025422	.578020	.0735539	1.868268	1

* 1 kPa = 1 kN/m², 1 mmHg = 1 Torr, 1Kg/cm² = 1 kp/cm²
(Conversions of: H₂O are at 39.2 °F (4 °C); Hg are at 32 °F (0 °C))

Fill Fluid Temperature Table

Fill Fluid	Temperature Range (°F)
Glycerin*	30 – 300
Silicone 200-10	-35 – 450
Silicone 710	30 – 650
Silicone 550	-40 – 600
Silicone 510	-60 – 400
Fluorolube FS-5	-40 – 500
Silicone 200-350	0 – 300
Halocarbon® Oil 6.3	-40 – 400
Ethylene Glycol	-30 – 300
Propylene Glycol	-50 – 200
Syltherm 800	-40 – 450
Neobee M-20	-40 – 320

* Not recommended for use on vacuum applications

CONVERSIONS FOR HYDRAULIC RAM CAPACITY

$$\text{psi} \times \text{AREA} = (\text{LBS.}) \text{ FORCE} \qquad \text{TONS} = \frac{\text{psi} \times .7854 \times \text{D}^2}{2000} \qquad \text{psi} = \frac{\text{TONS}}{\text{D}^2 \times .0003927}$$

For further assistance with conversions please consult the factory.



Shown with enhanced software.

1000 SERIES

- Rugged, electronic gauge
- Compound and standard ranges through 0 psig to 10,000 psig
- 3.31" gauge size
- Stainless steel case
- Stainless steel, aluminum, NBR and ceramic wetted parts
- CE compliant to suppress RFI, EMI and ESD

APPLICATIONS

- Hydraulics & pneumatics
- Laboratory & test equipment
- Leak detection
- Power generation
- Water management

OPTIONAL ENHANCED SOFTWARE FEATURES

- Tare function
- Password protection
- Min./max. memory
- Internal lighting
- 300° rotatable base



SPECIFICATIONS	
Pressure ranges	0 psig to 30 psig through 0 psig to 10,000 psig Compound from -30 inHg to 30 psig through -30 inHg to 600 psig
Accuracy	±0.25% full scale (BFSL): ±0.5% terminal point ±1 digit
Temperature ranges	Compensated 32 °F to 140 °F (0 °C to 60 °C) Effect ±0.15% per 10K at zero and span Span effect is ±0.005% full scale/ °F Media -22 °F to 185 °F (-30 °C to 85 °C) Ambient 14 °F to 140 °F (-10 °C to 60 °C) Storage -4 °F to 158 °F (-20 °C to 70 °C)
Measuring element	≤750 psig stainless steel, aluminum, NBR, ceramic measuring element ≥ 1000 psig stainless steel, thin-film measuring element
Connection	1/4" NPT Male, 316 stainless steel
Case	Stainless steel
Bezel	Stainless steel triangular
Display	Liquid Crystal Display with 0.43" digits 4 digits up to 9999 with bar graph
Power requirement*	2 x 1.5V "AA" battery 4,000 hrs ("AA" 2000 mAh)
Response time	200 ms
Proof pressure	2 times full scale range, maximum 15,000 psi
Programmable functions	Adjustable through front key pad
Measuring units	bar, psi, MPa
Peak memory	min/max, display, hold
Environmental rating	IP65
Electromagnetic rating	CE compliant to EMC norm EN 61326:1997/A1:1998 RFI, EMI and ESD protection
Weight	0.88 lb.

* Unregulated

Optional Gauge Carrying Case

ORDERING INFORMATION								
SERIES	1000							
PRESSURE RANGES	30/30	-30 inHg to 30 psig	30	0 psig to 30 psig	1450	0 psig to 1,450 psig	7500	0 psig to 7,500 psig
	30/60	-30 inHg to 60 psig	60	0 psig to 60 psig	2000	0 psig to 2,000 psig	10000	0 psig to 10,000 psig
	30/145	-30 inHg to 145 psig	145	0 psig to 145 psig	3000	0 psig to 3,000 psig		
	30/300	-30 inHg to 300 psig	300	0 psig to 300 psig	5000	0 psig to 5,000 psig		
	30/600	-30 inHg to 600 psig	600	0 psig to 600 psig	6000	0 psig to 6,000 psig		
	psig = gauge pressure		Other ranges available on request					
PROCESS CONNECTION	2 1/4" NPT male							
OPTIONS	1	Peak memory - standard	GC	Gauge Carrying Case	RCP	Rubber Case Protector		
	6	Enhanced software	ST8	Threaded Orifice				

Please consult your local NOSHOK Distributor or NOSHOK, Inc. for availability and delivery information.

EXAMPLE

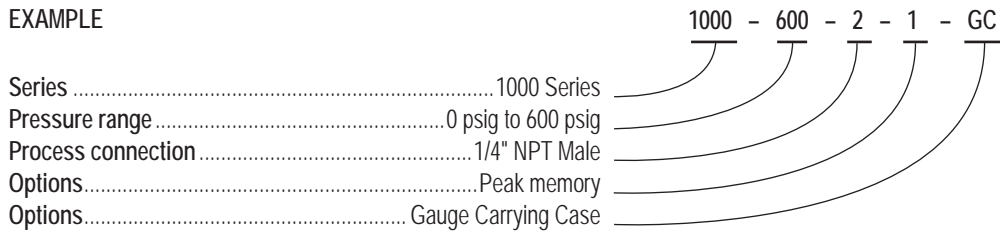



100 SERIES

- Vacuum and compound ranges through 0 psig to 15,000 psig
- Current output
- 316 and 17-4PH stainless steel wetted parts
- CE compliant to suppress RFI, EMI and ESD

APPLICATIONS

- HVAC
- Hydraulics & pneumatics
- Injection molding machines
- Railroad equipment
- Stamping & forming presses

SPECIFICATIONS

Output signal	4 mA to 20 mA, 2-wire
Pressure ranges	Vacuum through 0 psig to 15,000 psig Absolute from 0 psia to 15 psia through 0 psia to 300 psia
Accuracy	±0.5% full scale (BFSL); optional ±0.25% full scale (BFSL); (Includes the effects of non-linearity, hysteresis, non-repeatability, zero point and full scale errors)
Stability	≤ ±0.2% full scale for 1 year, non-accumulating
Adjustment	≤ ±10% full scale for zero and span
Response time	≤ 1 ms (between 10% and 90% full scale)
Pressure cycle limit	150 Hz
Durability	> 100,000,000 full scale cycles
Temperature ranges	Compensated 32 °F to 176 °F (0 °C to 80 °C) Effect ±0.017% full scale/ °F for zero and span Media -22 °F to 212 °F (-30 °C to 100 °C) Ambient -40 °F to 185 °F (-40 °C to 85 °C) Storage -40 °F to 212 °F (-40 °C to 100 °C)
Power requirement*	10 Vdc to 30 Vdc (4 mA to 20 mA, 2-wire)
Load limitations	≤ (Vpower supply -10)/0.020 Amp
Proof pressure	3 times full scale for ranges 0 psi to 5 psi through 0 psi to 200 psi 1.75 times full scale for ranges 0 psi to 300 psi through 0 psi to 10,000 psi 1.5 times full scale for 0 to 15,000 psi
Burst pressure	3.8 times full scale for ranges 0 psi to 5 psi through 0 psi to 200 psi 4 times full scale for ranges 0 psi to 300 psi through 0 psi to 10,000 psi 3 times full scale for 0 psi to 15,000 psi
Measuring element	316 stainless steel for vacuum through 300 psi; 17-4PH stainless steel for ≥500 psi
Connection	316 stainless steel
Housing material	316 stainless steel
Environmental rating	IP65
Electromagnetic rating	CE compliant to EMC norm EN 61326:1997/A1:1998 RFI, EMI and ESD protection
Electrical protection	Reverse polarity, over-voltage and short circuit protection
Shock	1000 g's according to IEC 60068-2-27
Vibration	30 g's according to IEC 60068-2-6
Weight	Approximately 3.5 oz.

* Unregulated

ORDERING INFORMATION											
SERIES	100										
PRESSURE RANGES	30vac	-30 inHg to 0 psig	5	0 psig to 5 psig	200	0 psig to 200 psig	3000	0 psig to 3,000 psig	15A	0 psia to 15 psia	
	30/15	-30 inHg to 15 psig	10	0 psig to 10 psig	300	0 psig to 300 psig	4000	0 psig to 4,000 psig	30A	0 psia to 30 psia	
	30/30	-30 inHg to 30 psig	15	0 psig to 15 psig	500	0 psig to 500 psig	5000	0 psig to 5,000 psig	60A	0 psia to 60 psia	
	30/45	-30 inHg to 45 psig	25	0 psig to 25 psig	600	0 psig to 600 psig	6000	0 psig to 6,000 psig	100A	0 psia to 100 psia	
	30/100	-30 inHg to 100 psig	30	0 psig to 30 psig	750	0 psig to 750 psig	7500	0 psig to 7,500 psig	150A	0 psia to 150 psia	
	30/150	-30 inHg to 150 psig	60	0 psig to 60 psig	1000	0 psig to 1,000 psig	10000	0 psig to 10,000 psig	200A	0 psia to 200 psia	
	30/200	-30 inHg to 200 psig	100	0 psig to 100 psig	1500	0 psig to 1,500 psig	15000	0 psig to 15,000 psig	300A	0 psia to 300 psia	
	30/300	-30 inHg to 300 psig	150	0 psig to 150 psig	2000	0 psig to 2,000 psig					
			psig = gauge pressure		psia = absolute pressure		Other ranges available on request				
ACCURACIES	1	±0.5% full scale (BFSL)			2	±0.25% full scale (BFSL)					
OUTPUT SIGNAL	1	4 mA to 20 mA, 2-wire									
PROCESS CONNECTIONS	1	1/8" NPT male			3	SAE J1926-3:7/16-20 Adjustable			9	SAE J1926-1:7/16-20	
	2	1/4" NPT male			4	1/8" NPT female			10	G1/4 male	
ELECTRICAL CONNECTIONS	1	36" cable (connected to option 7)			6	1/2" NPT conduit (with 36" cable)			25	M12 x 1 (4-pin)	
	2	4-pin Bendix			7	Mini-Hirschmann (DIN EN 175301-803 Form C)			36	Integral cable 36"	
	3	6-pin Bendix									
OPTION	ST8	Threaded Orifice									

Please consult your local NOSHOK Distributor or NOSHOK, Inc. for availability and delivery information.

EXAMPLE

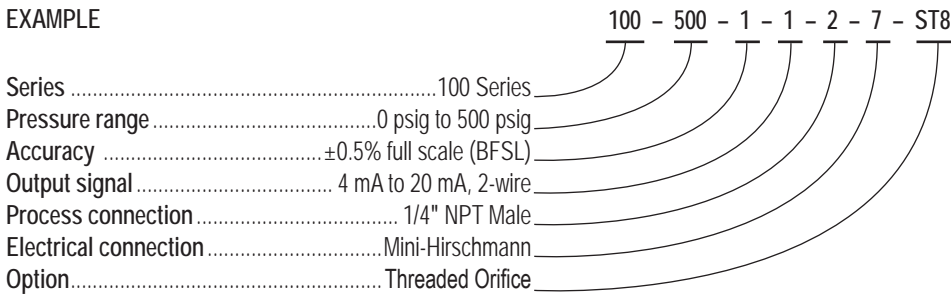

Load Limitations 4 mA to 20 mA output	
Vmin	= 10V + (.020 x RL)
RL	= Loop resistance (Ω) RL = RS + RW
RS	= Sensor resistance (Ω)
RW	= Wire resistance (Ω)



WIRING				
Wire	Bendix 4-pin or 6-pin	Mini-Hirschmann	Cable	M12 x 1
+ Supply	pin A	pin 1	Red	pin 1
+ Output	pin B	pin 2	Black	pin 3

* Note: Mate supplied separately or customer supplied.



200 SERIES

- Ranges from vacuum to 0 psig to 15,000 psig; absolute ranges from 0 psia to 15 psia through 0 psia to 300 psia
- Voltage output
- 316 and 17-4PH stainless steel wetted parts
- CE compliant to suppress RFI, EMI and ESD

APPLICATIONS

- HVAC
- Hydraulics & pneumatics
- Injection molding machines
- Railroad equipment
- Stamping & forming presses

SPECIFICATIONS

Output signals	0 Vdc to 5 Vdc, 3-wire; 0 Vdc to 10 Vdc, 3-wire; 1 Vdc to 5 Vdc, 3-wire; 1 Vdc to 6 Vdc, 3-wire; 1 Vdc to 11 Vdc, 3-wire
Pressure ranges	Vacuum through 0 psig to 15,000 psig Absolute from 0 psia to 15 psia through 0 psia to 300 psia
Accuracy	±0.5% full scale (BFSL); optional ±0.25% full scale (BFSL); (Includes the effects of non-linearity, hysteresis, non-repeatability, zero point and full scale errors)
Stability	≤ ±0.2% full scale per year, non-accumulating
Adjustment	±10% full scale for zero and span
Response time	≤ 1 ms (between 10% and 90% full scale)
Pressure cycle limit	150 Hz
Durability	> 100,000,000 full scale cycles
Temperature ranges	Compensated 32 °F to 176 °F (0 °C to 80 °C) Effect ±0.017% full scale/ °F for zero and span Media -22 °F to 212 °F (-30 °C to 100 °C) Ambient -40 °F to 185 °F (-40 °C to 85 °C) Storage -40 °F to 212 °F (-40 °C to 100 °C)
Power requirement*	10 Vdc to 30 Vdc (0 Vdc to 5 Vdc, 3-wire, 1 Vdc to 5 Vdc, 3-wire, 1 Vdc to 6 Vdc, 3-wire) 14 Vdc to 30 Vdc (0 Vdc to 10 Vdc, 3-wire, 1 Vdc to 11 Vdc, 3-wire)
Load limitations	≥ 5,000 Ω for 0 Vdc to 5 Vdc, 1 Vdc to 5 Vdc, and 1 Vdc to 6 Vdc outputs; ≥ 10,000 Ω for 0 Vdc to 10 Vdc and 1 Vdc to 11 Vdc outputs. Current consumption 8 mA
Proof pressure	3 times full scale for ranges 0 psi to 5 psi through 0 psi to 200 psi 1.75 times full scale for ranges 0 psi to 300 psi through 0 psi to 10,000 psi 1.5 times full scale for 0 psi to 15,000 psi
Burst pressure	3.8 times full scale for ranges 0 psi to 5 psi through 0 psi to 200 psi 4 times full scale for ranges 0 psi to 300 psi through 0 psi to 10,000 psi 3 times full scale for 0 psi to 15,000 psi
Measuring element	316 stainless steel for vacuum through 300 psi; 17-4PH stainless steel for ≥ 500 psi
Connection	316 stainless steel
Housing material	316 stainless steel
Environmental rating	IP65
Electromagnetic rating	CE compliant to EMC norm EN 61326:1997/A1:1998 RFI, EMI and ESD protection
Electrical protection	Reverse polarity, over-voltage and short circuit protection
Shock	1,000 g's according to IEC 60068-2-27
Vibration	30 g's according to IEC 60068-2-6
Weight	Approximately 3.5 oz.

* Unregulated

ORDERING INFORMATION										
SERIES	200									
PRESSURE RANGES	30vac	-30 inHg to 0 psig	30/300	-30 inHg to 300 psig	200	0 psig to 200 psig	3000	0 psig to 3,000 psig	15A	0 psia to 15 psia
	30/15	-30 inHg to 15 psig	5	0 psig to 5 psig	300	0 psig to 300 psig	4000	0 psig to 4,000 psig	30A	0 psia to 30 psia
	30/30	-30 inHg to 30 psig	10	0 psig to 10 psig	500	0 psig to 500 psig	5000	0 psig to 5,000 psig	60A	0 psia to 60 psia
	30/45	-30 inHg to 45 psig	15	0 psig to 15 psig	600	0 psig to 600 psig	6000	0 psig to 6,000 psig	100A	0 psia to 100 psia
	30/60	-30 inHg to 60 psig	30	0 psig to 30 psig	750	0 psig to 750 psig	7500	0 psig to 7,500 psig	150A	0 psia to 150 psia
	30/100	-30 inHg to 100 psig	60	0 psig to 60 psig	1000	0 psig to 1,000 psig	10000	0 psig to 10,000 psig	200A	0 psia to 200 psia
	30/150	-30 inHg to 150 psig	100	0 psig to 100 psig	1500	0 psig to 1,500 psig	15000	0 psig to 15,000 psig	300A	0 psia to 300 psia
	30/200	-30 inHg to 200 psig	150	0 psig to 150 psig	2000	0 psig to 2,000 psig				
			psig = gauge pressure		psia = absolute pressure		Other ranges available on request			
ACCURACIES	1	±0.5% full scale (BFSL)	2	±0.25% full scale (BFSL)						
OUTPUT SIGNALS	2	0 Vdc to 5 Vdc, 3-wire	3	1 Vdc to 5 Vdc, 3-wire	4	1 Vdc to 6 Vdc, 3-wire	5	0 Vdc to 10 Vdc, 3-wire	6	1 Vdc to 11 Vdc, 3-wire
PROCESS CONNECTIONS	1	1/8" NPT male	3	SAE J1926-3:7/16-20 adjustable		9	SAE J1926-1:7/16-20			
	2	1/4" NPT male	4	1/8" NPT female		10	G1/4 male			
ELECTRICAL CONNECTION	1	36" cable (connected to option 7)			6	1/2" NPT conduit (with 36" cable)		25	M12 x 1 (4-pin)	
	2	4-pin Bendix			7	Mini-Hirschmann (DIN EN 175301-803 form C)		36	Integral cable 36"	
	3	6-pin Bendix								
	NOTE: 0 Vdc to 5 Vdc and 0 Vdc to 10 Vdc outputs are also available in 4-wire configurations for use with other electrical systems.									
OPTION	ST8 Threaded Orifice									

Please consult your local NOSHOK Distributor or NOSHOK, Inc. for availability and delivery information.

EXAMPLE

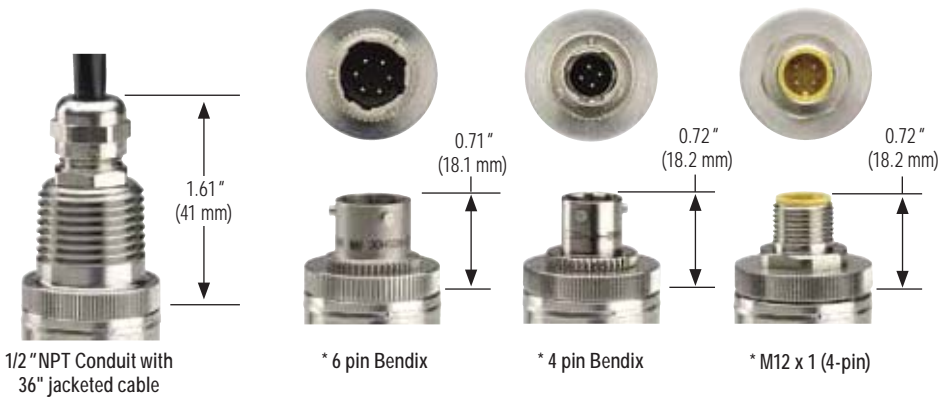
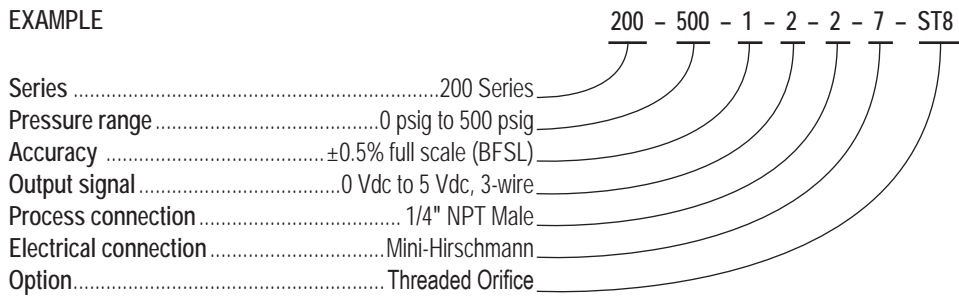

WIRING				
Wire	Bendix 4-pin or 6-pin	Mini-Hirschmann	Cable	M12 x 1
+ Supply	pin A	pin 1	Red	pin 1
Common	pin B	pin 2	Black	pin 3
+ Output	pin C	pin 3	White	pin 4

* Note: mate supplied separately or customer supplied



612 SERIES

- Ranges from 0 inH₂O to 50 inH₂O through 0 psig to 1,000 psig
- Current and voltage outputs available
- 316 stainless steel, polyamide and polyurethane wetted parts
- CE compliant to suppress RFI, EMI and ESD

APPLICATIONS

- Irrigation
- Tank monitoring
- Water & wastewater
- Well head measurement

SPECIFICATIONS

Output signals	4 mA to 20 mA, 2-wire; 0 Vdc to 5 Vdc and 0 Vdc to 10 Vdc, 3-wire; 0.5 Vdc to 2.5 Vdc, 3-wire
Pressure ranges	0 inH ₂ O to 50 inH ₂ O through 0 psig to 1,000 psig
Accuracy	± 0.25% full scale (BFSL); optional ± 0.125% full scale (BFSL); (includes the effects of non-linearity, hysteresis, non-repeatability, zero point and full scale errors)
Stability	≤ ± 0.2% full scale for 1 year, non-accumulating
Response time	≤ 1 ms (between 10% and 90% full scale)
Durability	> 100,000,000 full scale cycles
Temperature ranges	Compensated 32 °F to 122 °F/0 °C to 50 °C Effect ± 0.01%/ °F for zero and span Media 14 °F to 122 °F / -10 °C to 50 °C Storage -22 °F to 175 °F/-30 °C to 80 °C
Power requirement*	10 Vdc to 30 Vdc (4 mA to 20 mA, 2-wire, 0 Vdc to 5 Vdc, 3-wire) 5 Vdc to 30 Vdc (0.5 Vdc to 2.5 Vdc, 3-wire) 14 Vdc to 30 Vdc (0 Vdc to 10 Vdc, 3-wire)
Load limitations	≤ (VPower-10)/0.020 Amp for 4 mA to 20 mA ≥ 10,000 Ω for 0 Vdc to 10 Vdc, 3-wire ≥ 5,000 Ω for 0 Vdc to 5 Vdc, 3-wire
Proof pressure	2 times range
Burst pressure	4 times range
Measuring element	Cap: Polyamide, 316 stainless steel with weighted nosecone Cable: Polyurethane, optional FEP or PVC with double water block
Connection	316 stainless steel
Housing material	316 stainless steel
Environmental rating	IP68
Electromagnetic rating	CE compliant to EMC norm EN 61326:1997/A1:1998 RFI, EMI and ESD protection
Electrical protection	Reverse polarity protection, short circuit and optional lightning protection per EN 6100-4-5; 1.5J
Shock	100 g's according to IEC 60068-2-27
Vibration	15 g's according to IEC 60068-2-6
Weight	Approximately 7 oz. with standard nosecone - cable extra

* Unregulated

ORDERING INFORMATION								
SERIES	612							
PRESSURE RANGES	50 inH ₂ O	0 inH ₂ O to 50 inH ₂ O	2	0 psig to 2 psig (4.6 ftH ₂ O)	20	0 psig to 20 psig (46.2 ftH ₂ O)	200	0 psig to 200 psig (461.3 ftH ₂ O)
	100 inH ₂ O	0 inH ₂ O to 100 inH ₂ O	3	0 psig to 3 psig (6.9 ftH ₂ O)	25	0 psig to 25 psig (57.7 ftH ₂ O)	300	0 psig to 300 psig (692.5 ftH ₂ O)
	150 inH ₂ O	0 inH ₂ O to 150 inH ₂ O	5	0 psig to 5 psig (11.5 ftH ₂ O)	30	0 psig to 30 psig (69.2 ftH ₂ O)	350	0 psig to 350 psig (807.9 ftH ₂ O)
	200 inH ₂ O	0 inH ₂ O to 200 inH ₂ O	10	0 psig to 10 psig (23.1 ftH ₂ O)	60	0 psig to 60 psig (138.5 ftH ₂ O)	500	0 psig to 500 psig (1154.2 ftH ₂ O)
	400 inH ₂ O	0 inH ₂ O to 400 inH ₂ O	15	0 psig to 15 psig (34.6 ftH ₂ O)	100	0 psig to 100 psig (230.8 ftH ₂ O)	750	0 psig to 750 psig (1733.3 ftH ₂ O)
	psig = gauge pressure Other ranges available on request				150	0 psig to 150 psig (346.3 ftH ₂ O)	1000	0 psig to 1,000 psig (2311.0 ftH ₂ O)
ACCURACIES	1	±0.25% full scale (BFSL)			2	±0.125% full scale (BFSL)		
OUTPUT SIGNALS	1	4 mA to 20 mA, 2-wire			5	0 Vdc to 10 Vdc, 3-wire		
	2	0 Vdc to 5 Vdc, 3-wire			11	0.5 Vdc to 2.5 Vdc, 3-wire		
PROCESS CONNECTIONS	N	Nosecone			W	Nosecone w/added weight (1.1 lb.)		
	T	G 1/2 B x 1/2" NPT male with 1/4" NPT female						
ELECTRICAL CONNECTIONS	XX	Standard polyurethane (PUR) cable			38-XX	Optional FEP cable		
	22-XX	Optional water-blocked PVC cable (200+ psi only)						
		NOTE: XX = length of cable in feet.						
OPTIONS	PT1	PT100 RTD ¹	CBC	Cable Clamp	FE	Filter Element		
	DC	Desiccant Cartridge	LP	Lightning Protection ¹	JB	Cable Junction Box		

Please consult your local NOSHOK Distributor or NOSHOK, Inc. for availability and delivery information.

¹ Not available for PVC cable

EXAMPLE

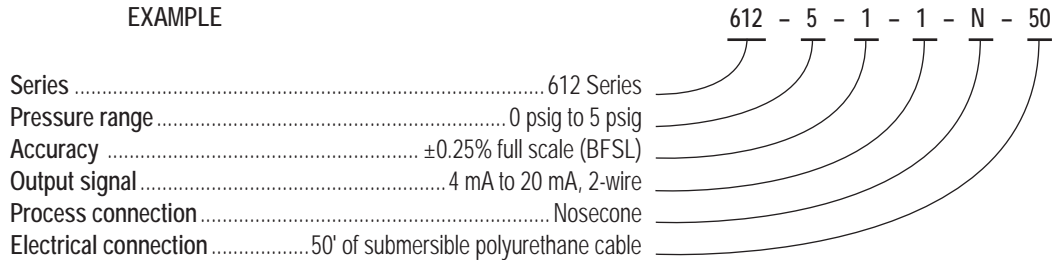

2-WIRE WIRING

Wiring	Cable
+ Supply	Red
+ Output	Black

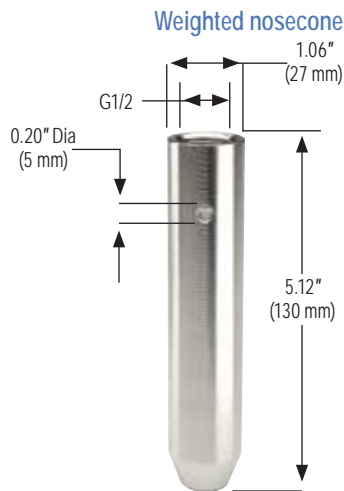

3-WIRE WIRING

Wiring	Cable
+ Supply	Red
Common	Black
+ Output	White

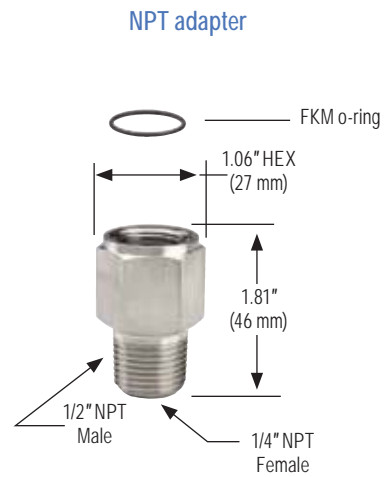

Cage-Protected Submersible



613 SERIES

- Ranges from 0 psi to 5 psi through 0 psi to 300 psi
- Current & voltage outputs available
- 316 stainless steel and polyurethane wetted parts
- CE compliant to suppress RFI, EMI and ESD

APPLICATIONS

- Lift stations
- Sewage
- Slurry tanks
- Storm canals
- Water & wastewater
- Wet wells

SPECIFICATIONS

Output signals	4 mA to 20 mA, 2-wire; 0 Vdc to 5 Vdc and 0 Vdc to 10 Vdc, 3-wire; 0.5 Vdc to 2.5 Vdc, 3-wire
Pressure ranges	0 psi to 5 psi through 0 psi to 300 psi
Accuracy	± 0.25% full scale (BFSL); optional ± 0.125% full scale (BFSL); (includes the effects of non-linearity, hysteresis, non-repeatability, zero point and full scale errors)
Stability	≤ ± 0.2% full scale for 1 year, non-accumulating
Response time	≤ 1 ms (between 10% and 90% full scale)
Durability	> 100,000,000 full scale cycles
Temperature measurement	Optional PT100, 4-wire per IEC 60751
Temperature ranges	Compensated 32 °F to 122 °F/0 °C to 50 °C Effect ± 0.01%/ °F for zero and span Media 14 °F to 122 °F / -10 °C to 50 °C Storage -22 °F to 175 °F/ -30 °C to 80 °C
Power requirement*	10 Vdc to 30 Vdc (4 mA to 20 mA, 2-wire, 0 Vdc to 5 Vdc, 3-wire) 5 Vdc to 30 Vdc (0.5 Vdc to 2.5 Vdc, 3-wire) 14 Vdc to 30 Vdc (0 Vdc to 10 Vdc, 3-wire)
Load limitations	≤ (VPower-10)/0.020 Amp for 4 mA to 20 mA ≥ 10,000 Ω for 0 Vdc to 10 Vdc, 3-wire ≥ 5,000 Ω for 0 Vdc to 5 Vdc, 3-wire
Proof pressure	2 times range
Burst pressure	4 times range
Measuring element	Cage seal: All 316 stainless steel Cable: Polyurethane, optional FEP
Connection	316 stainless steel
Housing material	316 stainless steel
Environmental rating	IP68
Electromagnetic rating	CE compliant to EMC norm EN 61326:1997/A1:1998 RFI, EMI and ESD protection
Electrical protection	Reverse polarity protection, short circuit and optional lightning protection per EN 6100-4-5; 1.5J
Shock	100 g's according to IEC 60068-2-27
Vibration	15 g's according to IEC 60068-2-6
Weight	Approximately 3.2 lb. - cable extra

* Unregulated

ORDERING INFORMATION								
SERIES	613							
PRESSURE RANGES	5	0 psi to 5 psi (11.55 ft/H ₂ O)	20	0 psi to 20 psi (46.20 ft/H ₂ O)	75	0 psi to 75 psi (173.25 ft/H ₂ O)	300	0 psi to 300 psi (693 ft/H ₂ O)
	10	0 psi to 10 psi (23.10 ft/H ₂ O)	30	0 psi to 30 psi (69.30 ft/H ₂ O)	100	0 psi to 100 psi (231.00 ft/H ₂ O)		
	15	0 psi to 15 psi (34.65 ft/H ₂ O)	50	0 psi to 50 psi (115.50 ft/H ₂ O)	150	0 psi to 150 psi (346.50 ft/H ₂ O)		
ACCURACIES	1	±0.25% full scale (BFSL)			2	±0.125% full scale (BFSL)		
OUTPUT SIGNALS	1	4 mA to 20 mA, 2-wire			5	0 Vdc to 10 Vdc, 3-wire		
	2	0 Vdc to 5 Vdc, 3-wire			11	0.5 Vdc to 2.5 Vdc, 3-wire		
ELECTRICAL CONNECTIONS	XX	Standard polyurethane (PUR) cable			38-XX	Optional FEP cable		
OPTIONS	CBC	Cable Clamp	FE	Filter Element	LP	Lightning Protection*	PT1	PT100 RTD*
	DC	Desiccant Cartridge	JB	Cable Junction Box	LR	Lifting Ring		

Please consult your local NOSHOK Distributor or NOSHOK, Inc. for availability and delivery information.

* Only available with PUR cable

EXAMPLE

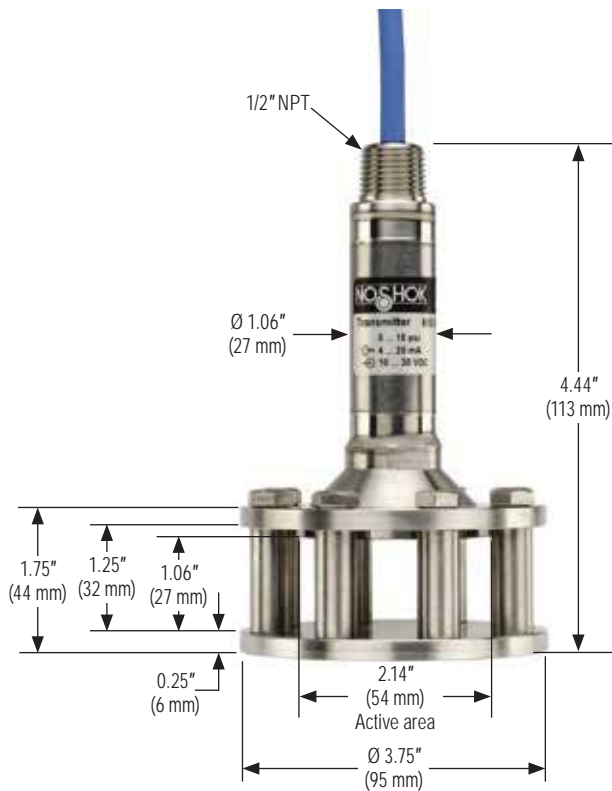
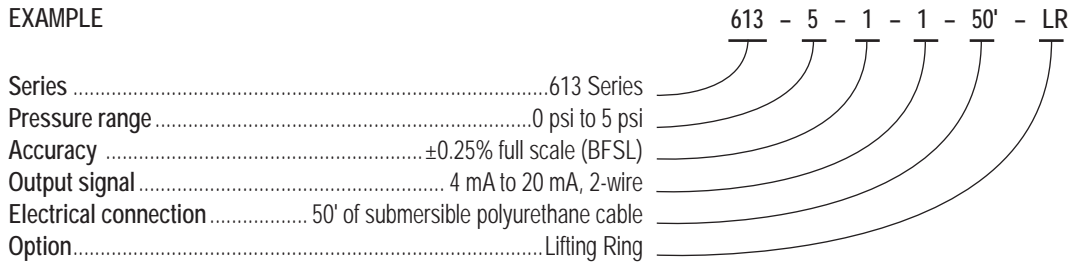

Optional Cable Clamp



Optional Cable Junction Box



Optional Filter Element



Optional Desiccant Cartridge



Optional Lifting Ring



615/616 SERIES

- Vacuum ranges through 0 psig to 145,000 psig; absolute ranges from 0 psia to 15 psia through 0 psia to 300 psia
- Current and voltage outputs available
- 316 and 17-4PH stainless steel wetted parts
- CE compliant to suppress RFI, EMI and ESD

APPLICATIONS

- Construction
- Hydraulics & pneumatics
- Laboratory & test equipment
- Power generation
- Stamping & forming presses
- Transportation



Also available with our 1800 Series Attachable Loop Indicator. Visit www.noshok.com for more information.

SPECIFICATIONS

Output signals	4 mA to 20 mA, 2-wire; 1 Vdc to 5 Vdc, 1 Vdc to 6 Vdc, 1 Vdc to 11 Vdc, 3-wire; 0 Vdc to 5 Vdc and 0 Vdc to 10 Vdc, 3-wire; 0 Vdc to 5 Vdc and 0 Vdc to 10 Vdc, 4-wire
Pressure ranges	Vacuum through 0 psig to 145,000 psig Absolute from 0 psia to 15 psia through 0 psia to 300 psia
Accuracy	± 0.25% full scale (BFSL); optional ± 0.125% full scale (BFSL); (includes the effects of non-linearity, hysteresis, non-repeatability, zero point and full scale errors)
Stability	≤ ±0.2% full scale for 1 year, non-accumulating
Adjustment	± 10% full scale for zero and span
Response time	Less than 1 ms (between 10% and 90% full scale)
Pressure cycle limit	150 Hz
Durability	>100,000,000 full scale cycles
Temperature ranges	Compensated 32 °F to 175 °F (0 °C to 80 °C) Effect ± 0.01%/ °F for zero and span Media -20 °F to 212 °F (-30 °C to 100 °C) Ambient -15 °F to 175 °F (-10 °C to 80 °C) Storage -40 °F to 212 °F (-40 °C to 100 °C)
Power requirement*	10 Vdc to 30 Vdc (4 mA to 20 mA, 2-wire, 1 Vdc to 5 Vdc, 3-wire, 1 Vdc to 6 Vdc, 3-wire, 0 Vdc to 5 Vdc, 3-wire) 14 Vdc to 30 Vdc (0 Vdc to 10 Vdc, 3-wire, 1 Vdc to 11 Vdc, 3-wire)
Load limitations	≤ (VPower-10)/0.020 Amp for 4 mA to 20 mA ≥ 10,000 Ω for 0 Vdc to 10 Vdc, 3-wire ≥ 5,000 Ω for 0 Vdc to 5 Vdc, 3-wire
Proof pressure	3 times full scale for ranges 0 psi to 2 psi through 0 psi to 200 psi 1.75 times full scale for ranges 0 psi to 300 psi through 0 psi to 10,000 psi 1.5 times full scale for 0 psi to 15,000 psi 1.2 times full scale for ranges 0 psi to 20,000 psi through 0 psi to 145,000 psi
Burst pressure	3.8 times full scale for ranges 0 psi to 2 psi through 0 psi to 200 psi 4 times full scale for ranges 0 psi to 300 psi through 0 psi to 10,000 psi 3 times full scale for 0 psi to 15,000 psi 1.5 times full scale for ranges 0 psi to 20,000 psi through 0 psi to 145,000 psi
Measuring element	316 stainless steel for vacuum through 300 psi; 17-4PH stainless steel for ≥500 psi
Connection	316 stainless steel
Housing material	316 stainless steel
Environmental rating	IP65
Electromagnetic rating	CE compliant to EMC norm EN 61326:1997/A1:1998 RFI, EMI and ESD protection
Electrical protection	Reverse polarity, overvoltage and short circuit protection
Shock	1,000 g's according to IEC 60068-2-27
Vibration	15 g's according to IEC 60068-2-6
Weight	Approximately 7.2 oz.

* Unregulated

ORDERING INFORMATION												
SERIES	615 (Internal diaphragm)			616 (Front flush diaphragm)								
PRESSURE RANGES	30vac	-30 inHg to 0 psig	2	0 psig to 2 psig	150	0 psig to 150 psig	2000	0 psig to 2,000 psig	20000	0 psig to 20,000 psig	145000	0 psig to 145,000 psig
	30/15	-30 inHg to 15 psig	3	0 psig to 3 psig	200	0 psig to 200 psig	3000	0 psig to 3,000 psig	30000	0 psig to 30,000 psig	15A	0 psia to 15 psia
	30/30	-30 inHg to 30 psig	5	0 psig to 5 psig	300	0 psig to 300 psig	4000	0 psig to 4,000 psig	36000	0 psig to 36,000 psig	30A	0 psia to 30 psia
	30/60	-30 inHg to 60 psig	10	0 psig to 10 psig	500	0 psig to 500 psig	5000	0 psig to 5,000 psig	58000	0 psig to 58,000 psig	60A	0 psia to 60 psia
	30/100	-30 inHg to 100 psig	15	0 psig to 15 psig	600	0 psig to 600 psig	6000	0 psig to 6,000 psig	72000	0 psig to 72,000 psig	100A	0 psia to 100 psia
	30/150	-30 inHg to 150 psig	30	0 psig to 30 psig	750	0 psig to 750 psig	7500	0 psig to 7,500 psig	87000	0 psig to 87,000 psig	150A	0 psia to 150 psia
	30/200	-30 inHg to 200 psig	60	0 psig to 60 psig	1000	0 psig to 1,000 psig	10000	0 psig to 10,000 psig	100000	0 psig to 100,000 psig	200A	0 psia to 200 psia
	30/300	-30 inHg to 300 psig	100	0 psig to 100 psig	1500	0 psig to 1,500 psig	15000	0 psig to 15,000 psig	115000	0 psig to 115,000 psig	300A	0 psia to 300 psia
psig = gauge pressure psia = absolute pressure Other ranges available on request Note: 616 Series is available for pressure ranges up to 0 psig to 8,000 psig												
ACCURACIES	1 ±0.25% full scale (BFSL)				2 ±0.125% full scale (BFSL)							
OUTPUT SIGNALS <small>*Ranges up to 0 psig to 60,000 psig</small>	1 4 mA to 20 mA, 2-wire				4 1 Vdc to 6 Vdc, 3-wire*							
	2 0 Vdc to 5 Vdc, 3-wire				5 0 Vdc to 10 Vdc, 3-wire							
	3 1 Vdc to 5 Vdc, 3-wire				6 1 Vdc to 11 Vdc, 3-wire*							
NOTE: 0 Vdc to 5 Vdc and 0 Vdc to 10 Vdc outputs are also available in 4-wire configurations for use with other electrical systems.												
PROCESS CONNECTIONS	615:	2 1/4" NPT male			6 9/16" -18 UNF 2B high pressure cone** (Standard on 30,000 to 120,000 psig)				8 1/2" NPT male			
	616:	11 G 1/2 B (Pressure ranges ≥ 0 psig to 30 psig)			13 G 1 B (Pressure ranges ≤ 0 psig to 30 psig)				Other connections available upon request			
ELECTRICAL CONNECTIONS	1 36" cable (connected to option 8)				8 Hirschmann (DIN EN 175301-803 Form A)				25 M12 x 1 (4-pin)			
	3 6-pin Bendix				14 Hirschmann type with 1/2" NPT female conduit				36 Integral 36" cable			
	6 1/2" NPT conduit w/ 36" cable											
OPTIONS	ST8 SS Threaded Orifice				G1 G 1 Weld-on adapter (616 only)				G½ G 1/2 Weld-on adapter (616 only)			

Please consult your local NOSHOK Distributor or NOSHOK, Inc. for availability and delivery information.

** Equivalent to F250C Parker Autoclave

EXAMPLE

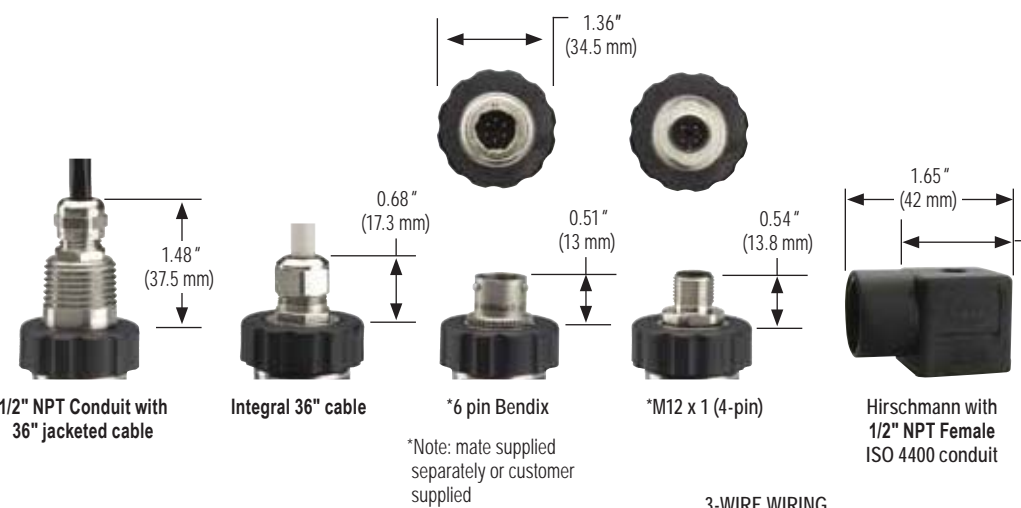
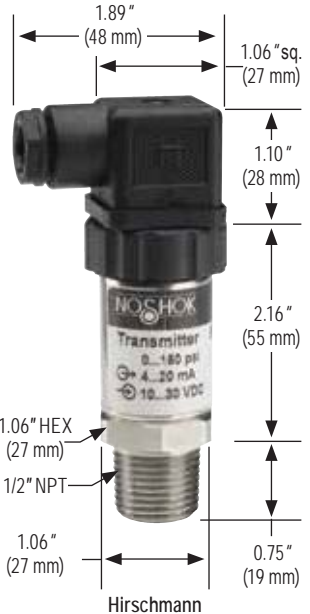
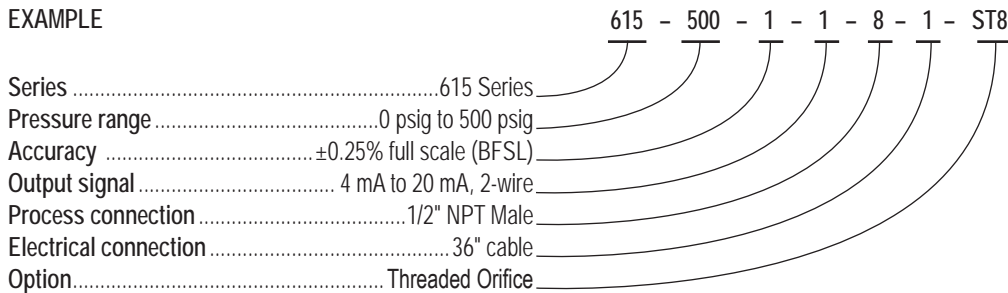

2-WIRE WIRING

	Hirschmann	Cable	M12	Bendix
+ Supply	1	Red	1	A
+ Output	2	Black	3	B

3-WIRE WIRING

	Hirschmann	Cable	M12	Bendix
+ Supply	1	Red	1	A
Common	2	Black	3	B
+ Output	3	White	4	C

NOTE
See 621/622 Series for G1/2B and G1B Front Flush Process Connection Dimensions pg. 85



640 SERIES

- Vacuum ranges through 0 psig to 15,000 psig; absolute ranges from 0 psia to 15 psia through 0 psia to 300 psia
- Standard 4 mA to 20 mA output
- 316 and 17-4PH stainless steel wetted parts
- CE compliant to suppress RFI, EMI and ESD

APPLICATIONS

- Aerospace equipment
- Computer interface & data logging
- Laboratory & test equipment
- Precision measurement

SPECIFICATIONS

Output signals	4 mA to 20 mA, 2-wire; 0 Vdc to 5 Vdc and 0 Vdc to 10 Vdc, 3-wire; USB
Pressure ranges	Vacuum through 0 psig to 15,000 psig Absolute from 0 to 15 psia through 0 psia to 300 psia
Accuracy	±0.05% full scale (BFSL); optional ±0.025% full scale (BFSL); (includes the effects of non-linearity, hysteresis, non-repeatability, zero point and full scale errors)
Stability	≤ ±0.1% full scale; 5 psi ±0.2% full scale per year
Adjustment	±5% full scale of zero and span
Response time	< 300 ms (between 10% to 90% full scale)
Pressure cycle limit	1 KHz
Durability	> 100,000,000 full scale cycles
Temperature ranges	Compensated 32 °F to 160 °F (0 °C to 70 °C) Effect: ±0.005% °F (32 °F to 50 °F) to zero point and pressure range no effect (50 °F to 104 °F) for zero and span ±0.005%/ °F (104 °F to 158 °F) to zero point and pressure range Media -5 °F to 160 °F (-20 °C to 70 °C) Ambient 32 °F to 160 °F (0 °C to 70 °C) Storage -5 °F to 160 °F (-20 °C to 70 °C)
Power requirement*	9 Vdc to 30 Vdc (4 mA to 20 mA, 2-wire, 0 Vdc to 5 Vdc, 3-wire) 14 Vdc to 30 Vdc (0 Vdc to 10 Vdc, 3-wire) Voltage supply via RS232 interface (RS232)
Load limitations	≤ (VPower-10)/0.020 Amp for 4 mA to 20 mA ≥ 10,000 Ω for 0 Vdc to 10 Vdc, 3-wire ≥ 5,000 Ω for 0 Vdc to 5 Vdc, 3-wire
Proof pressure	3 times full scale for ranges 0 psi to 5 psi through 0 psi to 200 psi 2 times full scale for ranges 0 psi to 300 psi through 0 psi to 10,000 psi 1.5 times full scale for 0 psi to 15,000 psi
Burst pressure	4 times full scale for ranges 0 psi to 5 psi through 0 psi to 200 psi 4 times full scale for ranges 0 psi to 300 psi through 0 psi to 10,000 psi 3 times full scale for 0 psi to 15,000 psi
Measuring element	316 stainless steel for vacuum through 300 psi; 17-4PH stainless steel for ≥500 psi
Connection	316 stainless steel
Housing material	316 stainless steel
Environmental rating	IP65
Electromagnetic rating	CE compliant to EMC norm EN 61326:1997/A1:1998 RFI, EMI and ESD protection
Electrical protection	Reverse polarity, overvoltage and short circuit protection
Shock	100 g's according to IEC 60068-2-27
Vibration	15 g's according to IEC 60068-2-6
Weight	Approximately 11 oz.

* Unregulated

ORDERING INFORMATION										
SERIES	640									
PRESSURE RANGES	30vac	-30 inHg to 0 psig	30/300	-30 inHg to 300 psig	150	0 psig to 150 psig	3000	0 psig to 3,000 psig	30A	0 psia to 30 psia
	30/15	-30 inHg to 15 psig	5	0 psig to 5 psig	200	0 psig to 200 psig	5000	0 psig to 5,000 psig	60A	0 psia to 60 psia
	30/30	-30 inHg to 30 psig	10	0 psig to 10 psig	300	0 psig to 300 psig	6000	0 psig to 6,000 psig	100A	0 psia to 100 psia
	30/60	-30 inHg to 60 psig	15	0 psig to 15 psig	500	0 psig to 500 psig	7500	0 psia to 7,500 psig	150A	0 psia to 150 psia
	30/100	-30 inHg to 100 psig	30	0 psig to 30 psig	750	0 psig to 750 psig	10000	0 psia to 10,000 psig	200A	0 psia to 200 psia
	30/150	-30 inHg to 150 psig	60	0 psig to 60 psig	1000	0 psig to 1,000 psig	15000	0 psia to 15,000 psig	300A	0 psia to 300 psia
	30/200	-30 inHg to 200 psig	100	0 psig to 100 psig	2000	0 psig to 2,000 psig	15A	0 psia to 15 psia		
	psig = gauge pressure			psia = absolute pressure		Other ranges available on request				
ACCURACIES	1 ±0.05% full scale (BFSL)			2 ±0.025% full scale (BFSL)						
OUTPUT SIGNALS	1 4 mA to 20 mA, 2-wire analog			5 0 Vdc to 10 Vdc, 3-wire analog			35 USB			
	2 0 Vdc to 5 Vdc, 3-wire analog			21 0 mA to 20 mA, 3-wire analog						
PROCESS CONNECTIONS	2 1/4" NPT male			8 1/2" NPT male; other connections available upon request						
ELECTRICAL CONNECTIONS	1 54" Integral cable		10 RS232-C w/58" cable & plug		25 M12 x 1 (4-pin)		47 USB			
OPTION	ST8 Threaded Orifice									

Please consult your local NOSHOK Distributor or NOSHOK, Inc. for availability and delivery information.

EXAMPLE

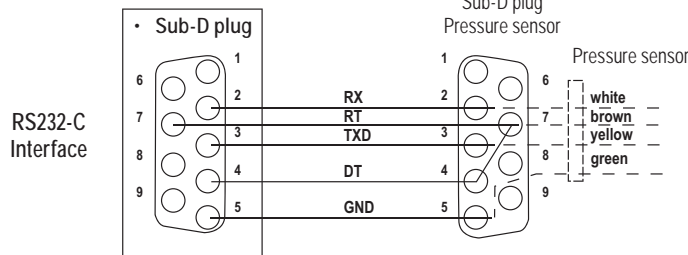
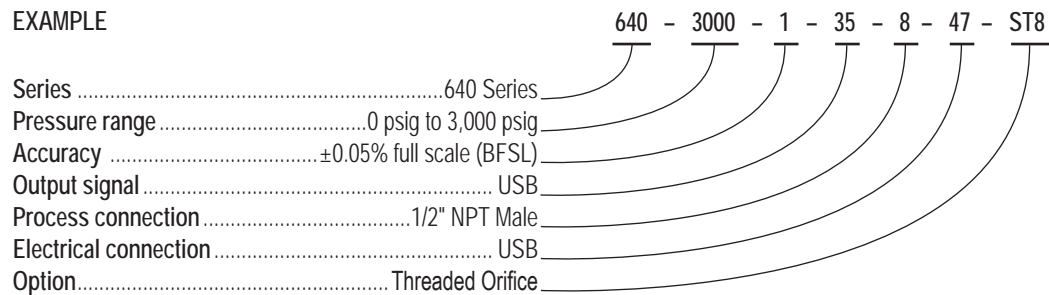

2-WIRE WIRING

Wiring	M12	Cable
+ Supply	1	Brown
+ Output	3	Green

3-WIRE WIRING

Wiring	M12	Cable
+ Supply	1	Brown
Common	3	Green
+ Output	4	White



660 SERIES

- Ranges from 0 psig to 200 through 0 psig to 15,000 psig
- Current & voltage outputs available
- Stainless steel wetted parts
- CE compliant to suppress RFI, EMI and ESD

APPLICATIONS

- Hydraulics & pneumatics
- Mobile hydraulics
- Power generation
- Pumps & compressors
- Refrigeration controls

SPECIFICATIONS

Output signals	4 mA to 20 mA 2-wire, 1 Vdc to 5 Vdc 3-wire; 0.1 Vdc to 10 Vdc, 3-wire
Pressure ranges	0 psig to 200 psig through 0 psig to 15,000 psig
Accuracy	±0.25% full scale (BFSL); (Includes the effects of non-linearity, hysteresis, non-repeatability, zero point and full scale errors)
Stability	≤ ±2% full scale for 1 year, non-accumulating
Response time	<2 ms (between 10% and 90% full scale)
Pressure cycle limit	150 Hz
Durability	> 100,000,000 full scale cycles
Temperature ranges	Compensated -4 °F to 185 °F (-20 °C to 85 °C) Zero effect ±0.01% full scale/ °F Span effect ±0.01% full scale/ °F Media -13 °F to 185 °F (-40 °C to 100 °C); -40 °F to 257 °F (-40 °C to 125 °C) available on request Ambient -4 °F to 185 °F (-25 °C to 85 °C) Storage -40 °F to 212 °F (-40 °C to 100 °C)
Power requirement*	10 Vdc to 36 Vdc (4 mA to 20 mA, 2-wire) 8 Vdc to 36 Vdc (1 Vdc to 5 Vdc, 3-wire) 14 Vdc to 36 Vdc (0.1 Vdc to 10 Vdc, 3-wire)
Load limitations	≤ (VPower-10)/0.020 Amp for 4 mA to 20 mA ≥ 10,000 Ω for 1 Vdc to 10 Vdc, 3-wire ≥ 5,000 Ω for 1 Vdc to 5 Vdc, 3-wire
Proof pressure	2 times full scale for ranges 0 psi to 200 psi through 0 psi to 10,000 psi 1.5 times full scale for 0 psi to 15,000 psi range
Burst pressure	9 times full scale for 0 psi to 200 psi through 0 psi to 1,000 psi 3 times full scale for ranges 0 to 3,000 psi through 0 psi to 15,000 psi
Measuring element	17-4PH stainless steel
Connection	316 stainless steel
Housing material	316 stainless steel
Environmental rating	IP65; IP67 M12x1 electrical connection for pressure ranges 0 psig to 1,500 psig or higher
Electromagnetic rating	CE compliant to EMC norm EN 61326:1997/A1:1998 RFI, EMI and ESD protection
Electrical protection	Reverse polarity, over-voltage and short circuit protection
Shock	1,000 g's according to IEC 60068-2-27
Vibration	20 g's according to IEC 60068-2-6
Weight	Approximately 1.75 oz.

* Unregulated

ORDERING INFORMATION				
SERIES	660			
PRESSURE RANGES	200	0 psig to 200 psig	500	0 psig to 500 psig
	300	0 psig to 300 psig	1000	0 psig to 1,000 psig
			3000	0 psig to 3,000 psig
			5000	0 psig to 5,000 psig
			10000	0 psig to 10,000 psig
			15000	0 psig to 15,000 psig
		psig = gauge pressure Other ranges available on request		
ACCURACY	1	±0.25% full scale (BFSL)		
OUTPUT SIGNALS	1	4 mA to 20 mA, 2-wire	3	1 Vdc to 5 Vdc, 3-wire
			27	0.1 Vdc to 10 Vdc, 3-wire
PROCESS CONNECTIONS	1	1/8" NPT male	2	1/4" NPT male
ELECTRICAL CONNECTIONS	1	3/6" cable (connected to option 7)	7	Mini-Hirschmann (DIN EN 175301-803 Form C)
			25	M12 x 1 (4-pin)
OPTION	ST8 Threaded Orifice			

Please consult your local NOSHOK Distributor or NOSHOK, Inc. for availability and delivery information.

EXAMPLE

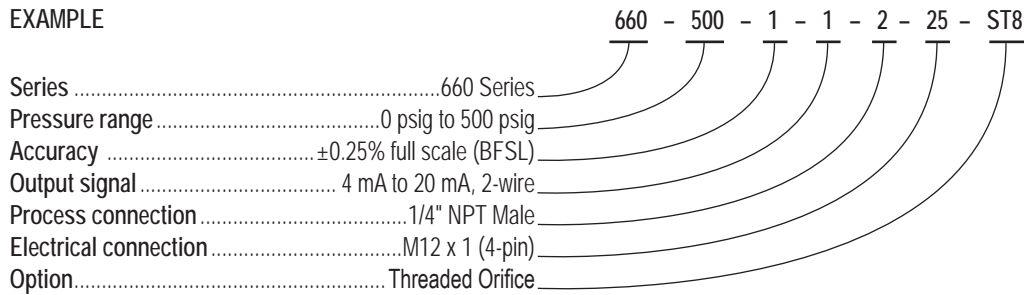

2-WIRE WIRING

Wiring	M12	Mini-Hirschmann	Cable
+ Supply	1	1	Red
+ Output	3	2	Black

3-WIRE WIRING

Wiring	M12	Mini-Hirschmann	Cable
+ Supply	1	1	Red
Common	3	2	Black
+ Output	4	3	White

Electronic Indicating Transmitter/Switch



800/810 SERIES

- Compound and standard switch adjustment ranges through 0 psig to 10,000 psig
- Stainless steel wetted parts
- Current and voltage outputs available
- 3 switching output options available:
 - 2 switching outputs
 - 1 switching output and 1 analog output (4 mA to 20 mA or 0 Vdc to 10 Vdc)
 - 2 switching outputs and 1 analog output (4 mA to 20 mA)
- CE compliant to suppress RFI, EMI and ESD

APPLICATIONS

- Hydraulics & pneumatics
- Power generation
- Pumps & compressors
- Stamping & forming presses
- Water & wastewater

Protective Cover Option

- Made of a thermoplastic polyurethane (TPU) material which is resistant to oil, grease and abrasion
- Protects the sensor while maintaining clear viewing and rotation of the display
- The elastic properties of the material allows set point programming without having to remove the cover
- Increases environmental protection to IP67 for indoor and outdoor use



SPECIFICATIONS

Switching parameters	Individually adjustable via external control keys
Number	1 or 2 (PNP or NPN)
Function	N.O./N.C.; windows - and hysteresis function freely adjustable
Contact rating	0.5 A max
Response time	<10 ms
Non-repeatability	<1% full scale
Pressure ranges	-14.5 psig to 30 psig through 0 psig to 9,999 psig
Switch adjustment	Programmable on the display
Switch point	1.0 to 100% of full scale
Hysteresis	0 to 99% of full scale
Transmitter parameters	
Output signal	4 mA to 20 mA or 0 Vdc to 10 Vdc; programmable and freely adjustable
Accuracy	< 0.5% full scale (BFSL) ±1 digit
Hysteresis	< 0.2% full scale (< 0.3 with pressure range < 0 psi - 230 psi)
Adjustment	20% to 100% depending on adjustment range
Durability	> 10,000,000 full scale cycles
Temperature ranges	Compensated 32 °F to 176 °F (0 °C to 80 °C)
	Zero ± 0.07% full scale/ °F
	Span ± 0.07% full scale/ °F
	Media -4 °F to 176 °F (-20 °C to 80 °C) (Thin film sensor)
	-4 °F to 176 °F (-20 °C to 80 °C) (Ceramic sensor)
	Ambient -4 °F to 158 °F (-20 °C to 70 °C)
	Storage -22 °F to 176 °F (-30 °C to 80 °C)
Power requirement*	12 Vdc to 30 Vdc
Current consumption	< 50 mA (without load)
Proof pressure	2 times full scale for ranges vacuum through 0 psig to 1,450 psig 1.75 times full scale for ranges 0 psig to 1,500 psig through 0 psig to 10,000 psig
Burst pressure	2.5 times full scale for ranges vacuum through 0 psig to 1,450 psig. 1.75 times full scale for ranges 0 psig to 1,500 psig through 0 psig to 10,000 psig
Measuring element	Stainless steel with ceramic sensor and FKM seal on ranges through 0 psig to 750 psig (other sealing materials available upon request). Stainless steel for higher pressure ranges
Housing material	800-stainless steel, 810-black anodized aluminum
Connection	316 stainless steel
Environmental rating	IP65
Electromagnetic rating	CE compliant to EMC norm EN 61326:1997/A1:1998 RFI, EMI and ESD protection
Electrical protection	Protected against reverse polarity, over-voltage and short circuit
Shock	> 50 g's according to IEC 60068-2-27
Vibration	> 10 g's according to IEC 60068-2-6
Weight	Approx 0.62 lb

* Unregulated

ORDERING INFORMATION				
SERIES	800	Stainless steel housing	810	Black anodized aluminum housing
SWITCH FUNCTIONS	1 2 N.O. or N.C. (PNP or NPN) 2 1 N.O. or 1 N.C. (PNP or NPN) with 4 mA to 20 mA analog output		3 1 N.O. or 1 N.C. (PNP or NPN) with 0 Vdc to 10 Vdc analog output 4 2 N.O. or 2 N.C. (NPN) with 4 mA to 20 mA analog output*	
PROCESS CONNECTIONS	2 1/4" NPT male 5 1/4" NPT female 8 1/2" NPT male		10 G 1/4 B male 11 G 1/2 B male 19 G 1/4 B female 45 SAE J1926-3:7/16-20	
ADJUSTABLE RANGES (Max. working pressure)	14.5/30 -14.5 psig to 30 psig 14.5/75 -14.5 psig to 75 psig 14.5/145 -14.5 psig to 145 psig 30 0 psig to 30 psig 75 0 psig to 75 psig		145 0 psig to 145 psig 300 0 psig to 300 psig 750 0 psig to 750 psig 1450 0 psig to 1,450 psig 2400 0 psig to 2,400 psig	
ELECTRICAL CONNECTIONS	2 M12 x 1 (4-pin)		3 M12 x 1 (5-pin), 2 switch and analog output	
OPTIONS	ST8 Threaded Orifice	RB Rotatable Base	EH Enhanced Software**	PC Protective Cover (IP67)

Please consult your local NOSHOK Distributor or NOSHOK, Inc. for availability and delivery information.

* Available only with a M12 x 1 (5-pin) connector. Rotatable base is not available on this option.
 ** Includes minimum/maximum value memory, output dampening, switching time delay

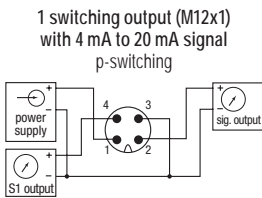

EXAMPLE

Series 800 Series
 Switch function..... 2 N.O. or N.C. (PNP or NPN)
 Process connection 1/4" NPT Male
 Adjustable range 0 psig to 145 psig
 Electrical connection M12 x 1 (4-pin)
 Option..... Threaded Orifice

800 - 1 - 2 - 145 - 2 - ST8

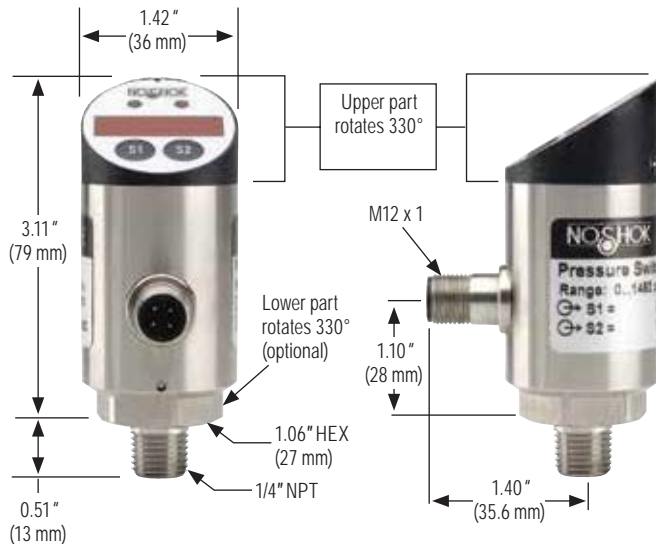
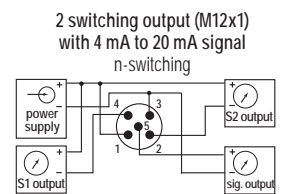
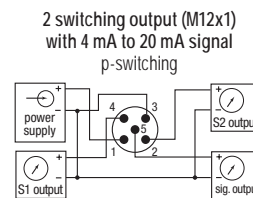
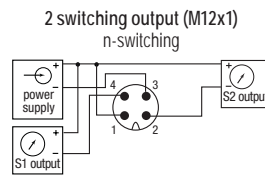
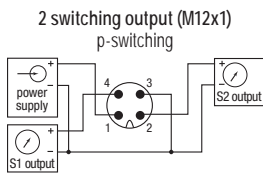
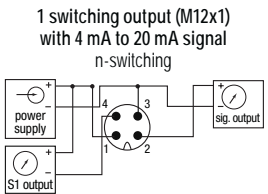
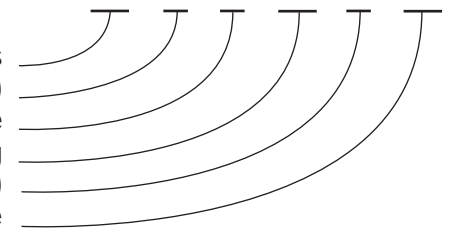

800 Series - Stainless Steel Housing



810 Series - Black Anodized Aluminum Housing



300 SERIES

- Ranges from 0 psig to 15 through 0 psig to 10,000 psig; absolute ranges from 0 psia to 15 psia through 0 psia to 300 psia
- Current and voltage outputs available
- 316 and 13-8PH stainless steel wetted parts
- RoHS compliant
- CE compliant to suppress RFI, EMI and ESD

SPECIFICATIONS

Output signals	4 mA to 20 mA, 2-wire; 0 Vdc to 5 Vdc, 3-wire; 1 Vdc to 5 Vdc, 3-wire; 0 Vdc to 10 Vdc, 3-wire; 0.5 Vdc to 4.5 Vdc ratiometric, 3-wire
Pressure ranges	0 psig to 15 psig through 0 psig to 10,000 psig Absolute from 0 psia to 15 psia through 0 psia to 300 psia
Accuracy	±0.5% full scale (BFSL); optional ±0.25% full scale (BFSL); (includes the effects of non-linearity, hysteresis, non-repeatability, zero point and full scale errors)
Stability	≤ ±0.2% full scale per year, non-accumulating
Response time	≤ 4 ms (between 10% and 90% full scale)
Pressure cycle limit	150 Hz
Durability	> 100,000,000 full scale cycles
Temperature ranges	Compensated 32 °F to 176 °F (0 °C to 80 °C) Media 32 °F to 176 °F (0 °C to 80 °C) Ambient 32 °F to 176 °F (0 °C to 80 °C) Storage -4 °F to 176 °F (0 °C to 80 °C)
Power requirement*	8 Vdc to 30 Vdc (4 mA to 20 mA, 2-wire, 0 Vdc to 5 Vdc, 3-wire, 1 Vdc to 5 Vdc, 3-wire, 0.5 Vdc to 4.5 Vdc, 3-wire) 14 Vdc to 30 Vdc (0 Vdc to 10 Vdc, 3-wire) 5 Vdc ± 10% (0.5 Vdc to 4.5 Vdc ratiometric, 3-wire)
Load limitations	≤ (VPower-10)/0.020 Amp for 4 mA to 20 mA output ≤ 5,000 Ω for 1 Vdc to 5 Vdc output ≤ 10,000 Ω for 0 Vdc to 10 Vdc output ≤ 4,500 Ω for 0.5 Vdc to 4.5 Vdc output
Proof pressure	2 times full scale
Burst pressure	6 times full scale
Measuring element	316 stainless steel for absolute through 150 psi 13-8PH stainless steel for ≥150 psi
Connection	316 stainless steel
Housing material	316 stainless steel
Environmental rating	IP65 to IP67 depending on electrical connection
Electromagnetic rating	CE compliant to EMC norm EN 61326:1997/A1:1998 RFI, EMI and ESD protection
Electrical protection	Reverse polarity, over-voltage and short circuit protection
Shock	500 g's according to IEC 60068-2-27
Vibration	10 g's according to IEC 60068-2-6
Weight	Approximately 2.8 oz.

* Unregulated

APPLICATIONS

- HVAC
- Hydraulics & pneumatics
- Injection molding machines
- Railroad equipment
- Stamping & forming presses

ORDERING INFORMATION				
SERIES	300			
PRESSURE RANGES	15	0 psig to 15 psig	300	0 psig to 300 psig
	30	0 psig to 30 psig	500	0 psig to 500 psig
	60	0 psig to 60 psig	750	0 psig to 750 psig
	100	0 psig to 100 psig	1000	0 psig to 1,000 psig
	150	0 psig to 150 psig	1500	0 psig to 1,500 psig
	200	0 psig to 200 psig	2000	0 psig to 2,000 psig
	3000	0 psig to 3,000 psig	5000	0 psig to 5,000 psig
6000	0 psig to 6,000 psig	7500	0 psig to 7,500 psig	
10000	0 psig to 10,000 psig	15A	0 psia to 15 psia	
30A	0 psia to 30 psia	60A	0 psia to 60 psia	
100A	0 psia to 100 psia	150A	0 psia to 150 psia	
200A	0 psia to 200 psia	300A	0 psia to 300 psia	
psig = gauge pressure psia = absolute pressure Other ranges available upon request.				
ACCURACIES	1	±0.5% full scale (BFSL)	2	±0.25% full scale (BFSL)
OUTPUT SIGNALS	1	4 mA to 20 mA, 2-wire	3	1 Vdc to 5 Vdc, 3-wire
	2	0 Vdc to 5 Vdc, 3-wire	5	0 Vdc to 10 Vdc, 3-wire
PROCESS CONNECTIONS	2	1/4" NPT male	10	G 1/4 B
	8	1/2" NPT male	11	G 1/2 B
ELECTRICAL CONNECTIONS	1	36" cable (connected to option 8)	8	Hirschmann (DIN EN 175301-803 form A)
	7	Mini-Hirschmann (DIN EN 175301-803 form C)	14	Hirschmann type with 1/2" NPT female conduit
	25	M12 x 1 (4-pin)	36	6' Integral cable
OPTION	ST8 Threaded Orifice (0.3 mm)			

Please consult your local NOSHOK Distributor or NOSHOK, Inc. for availability and delivery information.

EXAMPLE

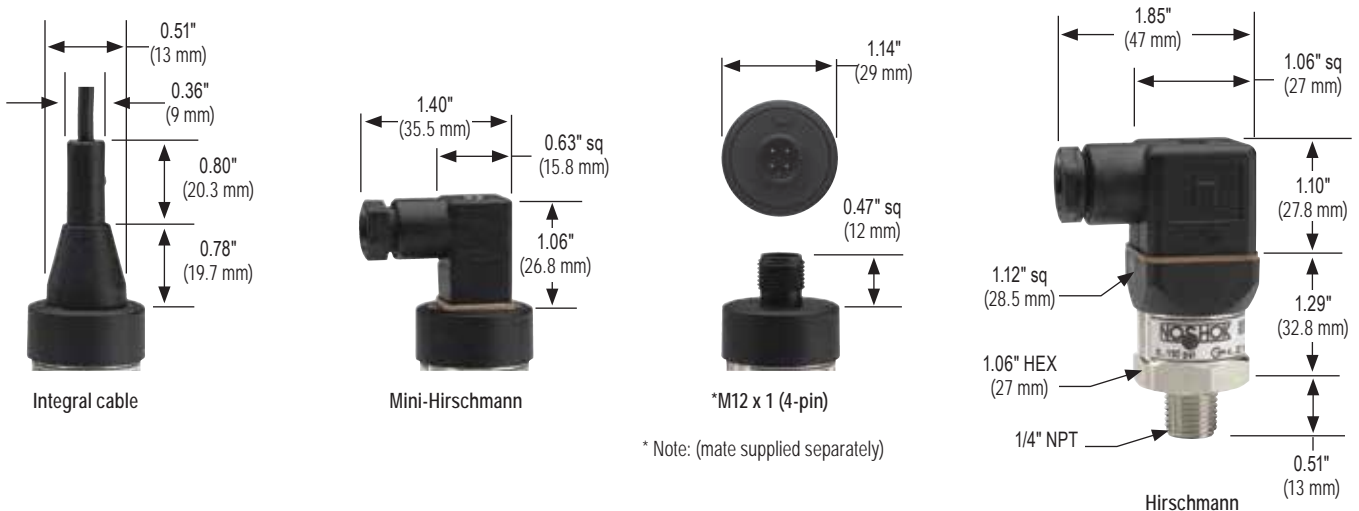
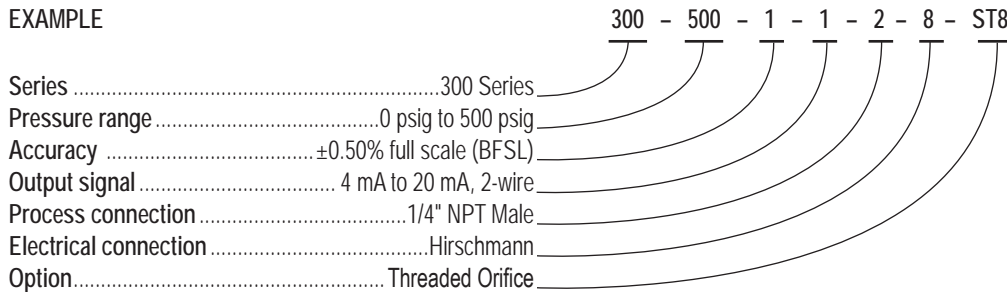

2-WIRE WIRING

Wiring	M12	Hirschmann	Cable
+ Supply	1	1	Brown
+ Output	3	2	Blue

3-WIRE WIRING

Wiring	M12	Hirschmann	Cable
+ Supply	1	1	Brown
Common	3	2	Blue
+ Output	4	3	White



650 SERIES

- Ranges from 0 psig to 100 psig through 0 psig to 8,000 psig
- Current and voltage outputs available
- Stainless steel wetted parts
- CE compliant to suppress RFI, EMI and ESD

APPLICATIONS

- Hydraulics & pneumatics
- Mobile hydraulics
- Pumps & compressors
- Refrigeration controls
- Transportation

SPECIFICATIONS

Output signals	4 mA to 20 mA 2-wire, or 1 Vdc to 5 Vdc 3-wire
Pressure ranges	0 psig to 100 psig through 0 psig to 8,000 psig
Accuracy	±0.50% full scale (BFSL) (Includes the effects of non-linearity, hysteresis, non-repeatability, zero point and full scale errors)
Stability	±0.2% full scale for 1 year, non-accumulating
Response time	< 5 ms (between 10% and 90% full scale); restrictor port I.D. to dampen pulsations
Pressure cycle limit	150 Hz
Durability	> 100,000,000 full scale cycles
Temperature ranges	Compensated 32 °F to 176 °F (0 °C to 80 °C) Zero effect ±0.008% full scale/ °F Span effect ±0.008% full scale/ °F Media -40 °F to 257 °F (-40 °C to 125 °C) Ambient -40 °F to 212 °F (-40 °C to 100 °C) Storage -40 °F to 248 °F (-40 °C to 120 °C)
Power requirement*	8 Vdc to 36 Vdc (4 mA to 20 mA, 2-wire, 0 Vdc to 5 Vdc, 3-wire, 1 Vdc to 5 Vdc, 3-wire, 0.5 Vdc to 4.5 Vdc, 3-wire) 14 Vdc to 36 Vdc (0 Vdc to 10 Vdc, 3-wire) 5 Vdc ± 10% (0.5 Vdc to 4.5 Vdc ratiometric, 3-wire)
Load limitations	≤ (VPower-10)/0.020 amp for 4 mA to 20 mA output ≤ 5,000 Ω for 1 Vdc to 5 Vdc output ≤ 10,000 Ω for 0 Vdc to 10 Vdc output ≤ 4,500 Ω for 0.5 Vdc to 4.5 Vdc output
Proof pressure	2 times full scale
Burst pressure	8 times full scale for ranges 0 psi to 100 psi through 0 psi to 1,500 psi 4 times full scale for ranges 0 psi to 2,000 psi through 0 psi to 8,000 psi
Measuring element	17-4PH stainless steel
Connection	316 stainless steel
Housing material	PBT - fiber reinforced plastic
Environmental rating	IP67 for M12x1 (4-pin) electrical connection and Metri-Pack connection; IP69K (steam jet cleaning) for cable connection
Electromagnetic rating	CE compliant to EMC norm EN 61326:1997/A1:1998 RFI, EMI and ESD protection
Electrical protection	Reverse polarity, over-voltage and short circuit protection
Shock	500 g's according to IEC 60068-2-27
Vibration	20 g's according to IEC 60068-2-6
Weight	Approximately 2.5 oz.

* Unregulated

ORDERING INFORMATION						
SERIES	650					
PRESSURE RANGES	100	0 psig to 100 psig	300	0 psig to 300 psig	600	0 psig to 600 psig
	150	0 psig to 150 psig	400	0 psig to 400 psig	750	0 psig to 750 psig
	200	0 psig to 200 psig	500	0 psig to 500 psig	1000	0 psig to 1,000 psig
	psig = gauge pressure		Other ranges available on request			
ACCURACY	1	±0.5% full scale (BFSL)				
OUTPUT SIGNALS	1	4 mA to 20 mA, 2-wire	3	1 Vdc to 5 Vdc, 3-wire	5	0 Vdc to 10 Vdc, 3-wire
PROCESS CONNECTIONS	2	1/4" NPT male	24	7/16-20 2B Schrader	45	SAE J1926-3:7/16-20
	10	G1/4B male	35	7/16-20 SAE with 45° flare		
ELECTRICAL CONNECTIONS	25	M12 x 1 (4-pin)	36	18" Integral cable IP67	45	AMP Superseal 1.5
	34	Metri-Pack 150 series	39	18" Integral cable IP69K	46	Deutsch (3-pin) DT04-3P

Please consult your local NOSHOK Distributor or NOSHOK, Inc. for minimum quantity requirements and delivery information.

EXAMPLE

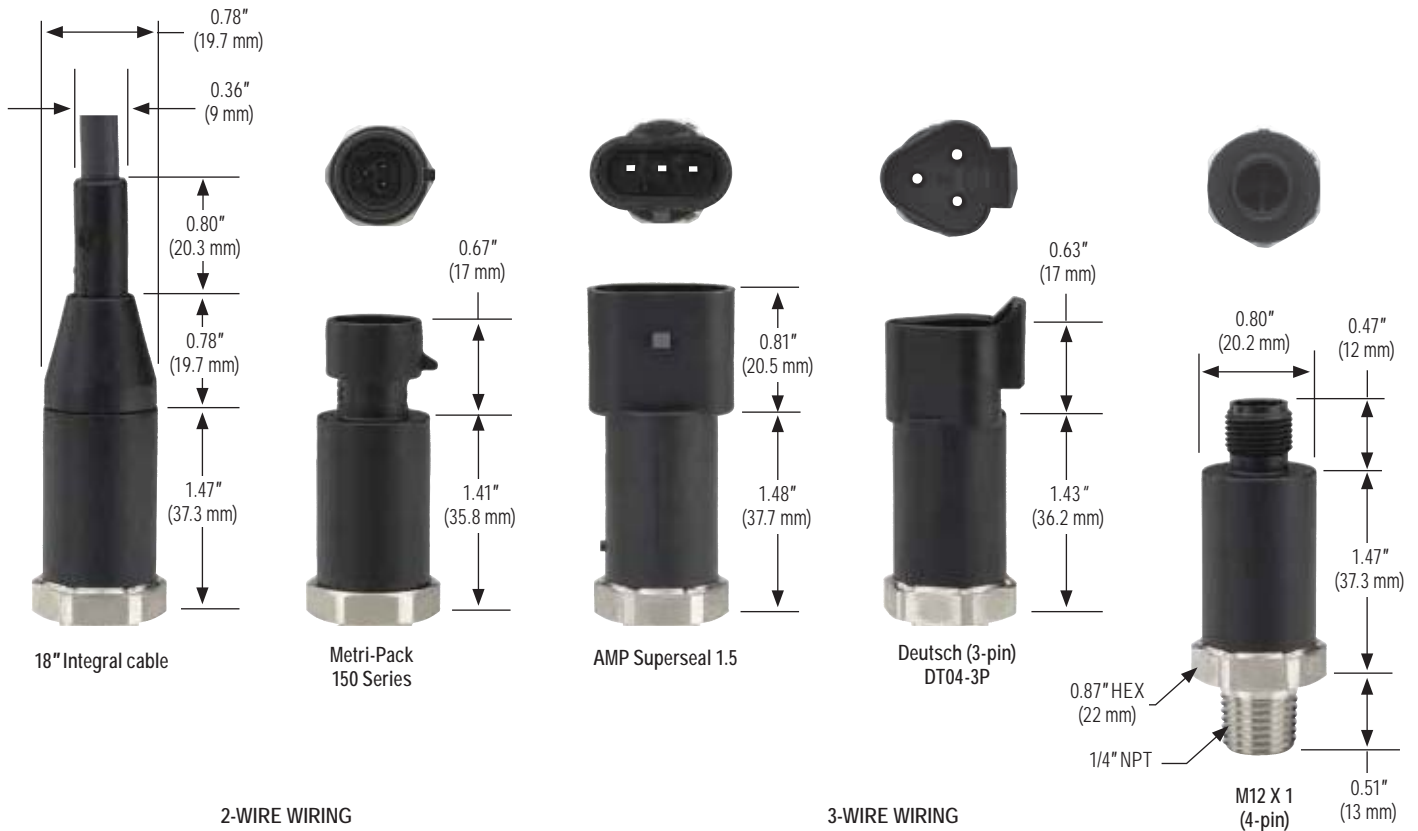
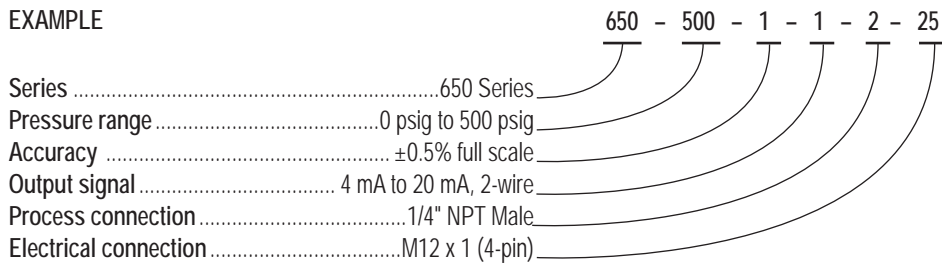

2-WIRE WIRING

Wiring	Cable	M12	Metri-Pack	AMP Superseal	Deutsch DT04-3P
+ Supply	Brown	1	B	3	A
+ Output	Black	3	A	1	B

3-WIRE WIRING

Wiring	Cable	M12	Metri-Pack	AMP Superseal	Deutsch DT04-3P
+ Supply	Brown	1	B	3	A
Common	Green	3	A	1	B
+ Output	White	4	C	2	C



619/620 SERIES

- Vacuum and compound ranges through 0 psig to 15,000 psig; absolute ranges from 0 psia to 15 psia through 0 psia to 100 psia
- Current and voltage outputs available
- 316 stainless steel and Elgiloy wetted parts
- ATEX-approved II 2G Ex d II C
- CE compliant to suppress RFI, EMI and ESD

APPLICATIONS

- Chemical processing
- Gas pressure measurement
- Oil field & offshore
- Mining
- Well head measurement

NOSHOK 619 and 620 Series transmitters are approved for use in hazardous location applications as follows:
 Explosion-proof protection type ATEX; EX d II c T4-T6.
 CE compliant with pressure equipment directive 97/23EC.

SPECIFICATIONS

Output signals	4 mA to 20 mA, 2-wire; 1 Vdc to 5 Vdc, 3-wire; 0 Vdc to 10 Vdc, 3-wire; 0.5 Vdc to 4.5 Vdc low power, 3-wire
Pressure ranges	Vacuum through 0 psig to 15,000 psig Absolute from 0 to 15 psia through 0 psia to 100 psia
Accuracy	±0.25% full scale (BFSL) (Includes the effects of non-linearity, hysteresis, non-repeatability, zero point and full scale errors)
Stability	≤±0.2% full scale for 1 year, non-accumulating
Response time	≤1 ms (between 10% and 90% full scale)
Pressure cycle limit	150 Hz
Durability	>100,000,000 full scale cycles
Temperature ranges	Compensated 32 °F to 176 °F (0 °C to 80 °C) Zero effect is ≤±0.011% full scale / °F Span effect is ≤±0.011% full scale / °F Media -40 °F to 221 °F (-40 °C to 105 °C) Ambient -40 °F to 221 °F (-40 °C to 105 °C) Storage -40 °F to 221 °F (-40 °C to 105 °C)
Power requirement*	10 Vdc to 30 Vdc (4 mA to 20 mA, 2-wire) 6 Vdc to 30 Vdc (1 Vdc to 5 Vdc, 3-wire, 0.5 Vdc to 4.5 Vdc, 3-wire) 14 Vdc to 30 Vdc (0 Vdc to 10 Vdc, 3-wire)
Load limitations	≤(VPower-10)/0.020 Amp for 4 mA to 20 mA >10,000 Ω for 1 Vdc to 5 Vdc, 3-wire and 0 Vdc to 10 Vdc > 5,000 Ω for 0.5 Vdc to 4.5 Vdc
Proof pressure	3.5 times full scale for ranges 0 psi to 15 psi through 0 psi to 200 psi 2 times full scale for ranges 0 psi to 300 psi through 0 psi to 10,000 psi 1.5 times full scale for 0 psi to 15,000 psi
Burst pressure	5 times full scale for ranges 0 psi to 15 psi through 0 psi to 200 psi 3.5 times full scale for ranges 0 psi to 300 psi through 0 psi to 10,000 psi 3 times full scale for 0 psi to 15,000 psi
Measuring element	619 Series is 316 stainless steel for ranges up through 0 psi to 300 psi, 316 stainless steel with Elgiloy for ranges 0 psi to 500 psi and higher; 620 Series is 316 stainless steel with NBR o-ring; optional FPM or EPDM o-ring
Connection	316 stainless steel
Housing material	316 stainless steel
Environmental rating	IP67
Electromagnetic rating	CE compliant to EMC norm EN 61326:1997/A1:1998 RFI, EMI and ESD protection
Electrical protection	Reverse polarity, over voltage and short circuit protection
Shock	1000 g's according to IEC 60068-2-27
Vibration	20 g's according to IEC 60068-2-6
Weight	Approximately 8 oz.

* Unregulated

ORDERING INFORMATION						
SERIES	619 Stainless steel threaded connection			620 316 Stainless steel flush diaphragm		
PRESSURE RANGES	30vac	-30 inHg to 0 psig	60	0 psig to 60 psig	1500	0 psig to 1,500 psig
	30/30	-30 inHg to 30 psig	100	0 psig to 100 psig	2000	0 psig to 2,000 psig
	30/60	-30 inHg to 60 psig	200	0 psig to 200 psig	3000	0 psig to 3,000 psig
	30/100	-30 inHg to 100 psig	300	0 psig to 300 psig	5000	0 psig to 5,000 psig
	15	0 psig to 15 psig	500	0 psig to 500 psig	8000	0 psig to 8,000 psig
	30	0 psig to 30 psig	1000	0 psig to 1,000 psig	10000	0 psig to 10,000 psig
	psig = gauge pressure psia = absolute pressure Other ranges available on request		Note: 620 Series is available for pressure ranges up to 0 psig to 8,000 psig			
ACCURACY	1 ±0.25% full scale (BFSL)					
OUTPUT SIGNALS	1 4 mA to 20 mA, 2-wire		3 1 Vdc to 5 Vdc, 3-wire, low power		31 0.5 Vdc to 4.5 Vdc 3-wire, low power	
PROCESS CONNECTIONS	2 1/4" NPT male		11 G 1/2 B*			
	8 1/2" NPT male		13 G 1 B (620 Series only, <30 psig)			
ELECTRICAL CONNECTION	6 1/2" NPT male conduit with 6' integral cable					
OPTIONS	ST8 Threaded Orifice (619 Series only)			15 15' Cable/lead (attached to option 6)		

Please consult your local NOSHOK Distributor or NOSHOK, Inc. for availability and delivery information.

* 620 Series only, G 1/2 B Flush (≥ 30 psig).

EXAMPLE

Series 619 Series
 Pressure range 0 psig to 500 psig
 Accuracy ±0.25% full scale (BFSL)
 Output signal 4 mA to 20 mA, 2-wire
 Process connection 1/2" NPT Male
 Electrical connection 1/2" NPT Male conduit with 6' integral cable
 Option Threaded Orifice

619 - 500 - 1 - 1 - 8 - 6 - ST8

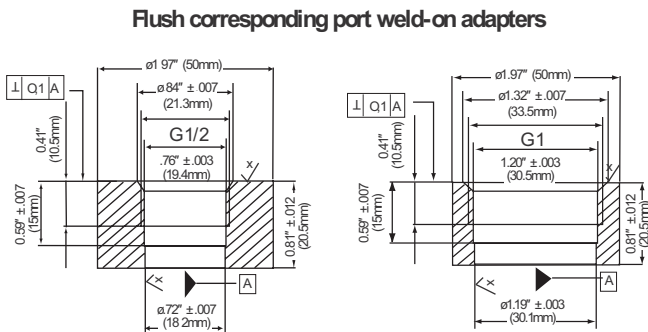
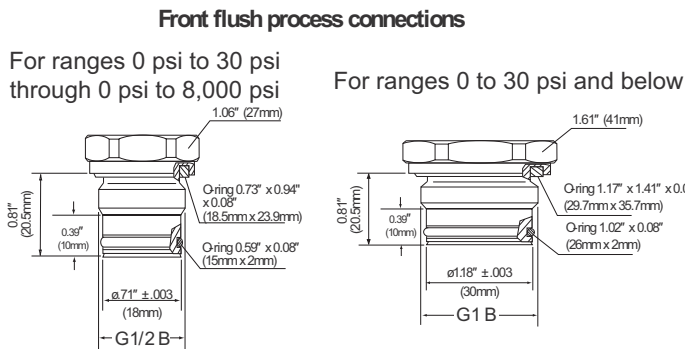

2-WIRE WIRING		3-WIRE WIRING	
+ Supply	Red	+ Supply	Red
+ Output	Black	Common	Black
		+ Output	Brown

Explosion-Proof



621/622 SERIES

- Vacuum and compound ranges through 0 psig to 15,000 psig; absolute ranges from 0 psia to 15 psia through 0 psia to 100 psia
- Current and voltage outputs available
- 316 stainless steel and Elgiloy wetted parts
- Factory Mutual and Canadian Standards Association approved
- CE compliant to suppress RFI, EMI and ESD
- NACE MR0175/ISO 15156 compliant
- NSI/ISA-12.27.01-2003 approved single seal

APPLICATIONS

- Chemical processing
- Gas pressure measurement
- Oil field & offshore
- Mining
- Well head measurement

NOSHOK 621 and 622 Series transmitters are Factory Mutual and Canadian Standards Association approved for use in hazardous location applications as follows:
 Explosion-proof with entity approval for: Class I, Division 1, Groups A, B, C and D. Dust Ignition-proof with entity approval for class II/III, Division 1, Groups E, F and G. Maximum electrical ratings 30V, 20 mA.
 CE compliant with pressure equipment directive 97/23EC.
 ANSI/ISA-12.27.01-2003, Approved single seal.

SPECIFICATIONS

Output signals	4 mA to 20 mA, 2-wire; 1 Vdc to 5 Vdc, 3-wire; 0.5 Vdc to 4.5 Vdc, 3-wire	
Pressure ranges	Vacuum through 0 psi to 15,000 psi Absolute from 0 psia to 15 psia through 0 psia to 100 psia	
Accuracy	±0.25% full scale (BFSL) (Includes the effects of non-linearity, hysteresis, non-repeatability, zero point and full scale errors)	
Stability	≤±0.2% full scale for 1 year, non-accumulating	
Response time	≤1 ms (between 10% and 90% full scale)	
Pressure cycle limit	150 Hz	
Durability	>100,000,000 full scale cycles	
Temperature ranges	Compensated	32 °F to 176 °F (0 °C to 80 °C)
	Zero effect	±0.011% full scale/ °F
	Span effect	±0.011% full scale/ °F
	Media	T6: -40 °F to 131 °F (-40 °C to 55 °C) T5: -40 °F to 158 °F (-40 °C to 70 °C) T4: -40 °F to 212 °F (-40 °C to 100 °C)
	Ambient	T6: -40 °F to 140 °F (-40 °C to 60 °C) T5: -40 °F to 167 °F (-40 °C to 75 °C) T4: -40 °F to 221 °F (-40 °C to 105 °C)
Storage	-40 °F to 221 °F (-40 °C to 105 °C)	
Power requirement*	10 Vdc to 30 Vdc (4 mA to 20 mA, 2-wire)	
	6 Vdc to 30 Vdc (1 Vdc to 5 Vdc, 3-wire; 0.5 Vdc to 4.5 Vdc, 3-wire)	
	14 Vdc to 30 Vdc (0 Vdc to 10 Vdc, 3-wire)	
Load limitations	≤ (VPower-10)/0.020 Amp for 4 mA to 20 mA ≥ 10,000 Ω for 1 Vdc to 5 Vdc, 3-wire	
Proof pressure	3 times full scale for ranges 0 psi to 15 psi through 0 psi to 200 psi 1.75 times full scale for ranges 0 psi to 300 psi through 0 psi to 10,000 psi 1.5 times full scale for 0 psi to 15,000 psi	
Burst pressure	3.8 times full scale for ranges 0 psi to 15 psi through 0 psi to 200 psi 4 times full scale for ranges 0 psi to 300 psi through 0 psi to 10,000 psi 3 times full scale for 0 psi to 15,000 psi	
Measuring element	621 Series is 316 stainless steel for ranges up through 0 psi to 300 psi, 316 stainless steel with Elgiloy ranges 0 psig to 500 psig and higher; 622 Series is 316 stainless steel with NBR o-ring; (FKM o-ring optional)	
Connection	316 stainless steel	
Housing material	316 stainless steel	
Environmental rating	IP67	
Electromagnetic rating	CE compliant to EMC norm EN 61326:1997/A1:1998 RFI, EMI and ESD protection	
Electrical protection	Reverse polarity, over-voltage and short circuit protected	
Shock	1,000 g's according to IEC 60068-2-27	
Vibration	20 g's according to IEC 60068-2-6	
Weight	Approximately 12 oz.	

* Unregulated

ORDERING INFORMATION						
SERIES	621	Stainless steel threaded connection	622	316 Stainless steel flush diaphragm	622H	Hastelloy C flush diaphragm
PRESSURE RANGES	30vac	-30 inHg to 0 psig	15	0 psig to 15 psig	500	0 psig to 500 psig
	30/30	-30 inHg to 30 psig	30	0 psig to 30 psig	1000	0 psig to 1,000 psig
	30/60	-30 inHg to 60 psig	60	0 psig to 60 psig	1500	0 psig to 1,500 psig
	30/100	-30 inHg to 100 psig	100	0 psig to 100 psig	2000	0 psig to 2,000 psig
	30/200	-30 inHg to 200 psig	200	0 psig to 200 psig	3000	0 psig to 3,000 psig
		psig = gauge pressure psia = absolute pressure	300	0 psig to 300 psig	5000	0 psig to 5,000 psig
			Other ranges available on request		Note: 622 Series is available for pressure ranges up to 0 psig to 8,000 psig	
ACCURACY	1	±0.25% full scale (BFSL)				
OUTPUT SIGNALS	1	4 mA to 20 mA, 2-wire		3	1 Vdc to 5 Vdc, 3-wire, low power	
	2	0 Vdc to 5 Vdc, 3-wire		5	0 Vdc to 10 Vdc, 3-wire	
PROCESS CONNECTIONS	2	1/4" NPT male		11	G 1/2 B*	
	8	1/2" NPT male		13	G 1 B (622 Series only, <30 psig)	
ELECTRICAL CONNECTIONS	6	1/2" NPT male conduit with 6' integral cable		37	1/2" NPT male conduit with 6' flying leads with epoxy seal	
OPTIONS	ST8	Threaded Orifice (621 Series only)		20	20' Cable/lead (attached to electrical connection 6 or 37)	
				30	30' Cable/lead (attached to electrical connection 6 or 37)	

Please consult your local NOSHOK Distributor or NOSHOK, Inc. for availability and delivery information.

* 622 Series only, G 1/2 B Flush (≥ 30 psig).

EXAMPLE

Series 621 Series
 Pressure range 0 psig to 500 psig
 Accuracy ±0.25% full scale (BFSL)
 Output signal 4 mA to 20 mA, 2-wire
 Process connection 1/2" NPT Male
 Electrical connection 1/2" NPT Male conduit with 6' integral cable
 Option Threaded Orifice

621 - 500 - 1 - 1 - 8 - 6 - ST8

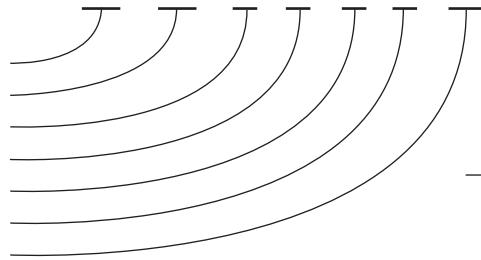

Front flush process connections

For ranges 0 psi to 30 psi through 0 psi to 8,000 psi

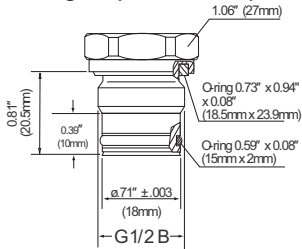

For ranges 0 to 30 psi and below

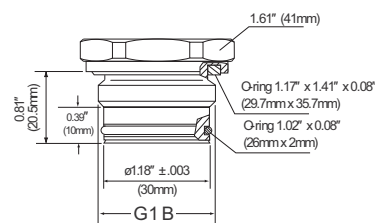

Flush corresponding port weld-on adapters

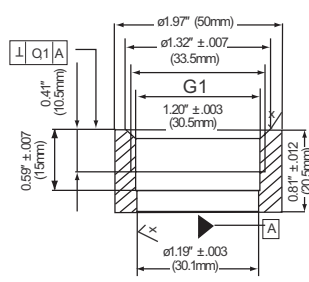
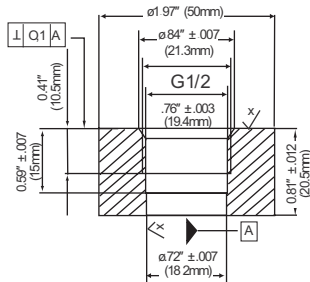

2-WIRE WIRING

+ Supply	Red
+ Output	Black
Ground	Gray

3-WIRE WIRING

+ Supply	Red
Common	Black
+ Output	Brown
Ground	Gray



623/624 SERIES

- Vacuum and compound ranges through 0 psig to 15,000 psig; absolute ranges from 0 psia to 15 psia through 0 psia to 100 psia
- Current and voltage outputs available
- 316 stainless steel and Elgiloy wetted parts
- Factory Mutual and Canadian Standards Association approved
- CE compliant to suppress RFI, EMI and ESD
- NACE MR0175/ISO 15156 compliant
- NSI/ISA-12.27.01-2003 approved single seal

APPLICATIONS

- Chemical processing
- Gas pressure measurement
- Oil field & offshore
- Mining
- Well head measurement

NOSHOK 623 and 624 Series transmitters are Factory Mutual and Canadian Standards Association approved for use in hazardous location applications as follows:
 Non-Incendive for: Class I, Division 2, Groups A, B, C and D.I.P;
 Class II, Division 1, Groups E, F and G Maximum ratings 30 Vdc, 20 mA.
 CE compliant with pressure equipment directive 97/23EC.
 ANSI/ISA-12.27.01-2003, Approved single seal.

SPECIFICATIONS

Output signals	4 mA to 20 mA, 2-wire; 1 Vdc to 5 Vdc low power, 3-wire; 0.5 Vdc to 4.5 Vdc low power, 3-wire
Pressure ranges	Vacuum through 0 psig to 15,000 psig Absolute through 0 psia to 100 psia
Accuracy	±0.25% full scale (BFSL) (Includes the effects of non-linearity, hysteresis, non-repeatability, zero point and full scale errors)
Stability	≤ ±0.2% full scale for 1 year, non-accumulating
Response time	≤1 ms (between 10% and 90% full scale)
Pressure cycle limit	150 Hz
Durability	>100,000,000 full scale cycles
Temperature ranges	Compensated 32 °F to 176 °F (0 °C to 80 °C) Zero effect is ±0.011% full scale/ °F within compensated range Span effect is ±0.011% full scale/ °F within compensated range Media -40 °F to 212 °F (-40 to 100 °C) Ambient -22 °F to 176 °F (-30 °C to 80 °C) Storage -22 °F to 212 °F (-30 °C to 100 °C)
Power requirement*	10 Vdc to 30 Vdc (4 mA to 20 mA, 2-wire) 6 Vdc to 30 Vdc (1 Vdc to 5 Vdc, 3-wire, 0.5 Vdc to 4.5 Vdc, 3-wire) 14 Vdc to 30 Vdc (0 Vdc to 10 Vdc, 3-wire)
Load limitations	≤ (VPower -10)/0.020 Amp for 4 mA to 20 mA; ≥ 10,000 Ω for 1 Vdc to 5 Vdc, 3-wire
Proof pressure	3 times full scale for ranges 0 psi to 15 psi through 0 psi to 200 psi 1.75 times full scale for ranges 0 psi to 300 psi through 0 psi to 10,000 psi 1.5 times full scale for 0 psi to 15,000 psi range
Burst pressure	3.8 times full scale for ranges 0 psi to 15 psi through 0 psi to 200 psi 4 times full scale for ranges 0 psi to 300 psi through 0 psi to 10,000 psi 3 times full scale for 0 psi to 15,000 psi
Measuring element	623 Series is 316 stainless steel for ranges up through 0 psi to 300 psi, 316 stainless steel and Elgiloy for ranges 0 psig to 500 psig and higher; 624 Series is 316 stainless steel with NBR o-ring; FKM o-ring optional
Connection	316 stainless steel
Housing material	316 stainless steel
Environmental rating	IP65 to IP67 dependent upon electrical connection
Electromagnetic rating	CE compliant to EMC norm EN 61326:1997/A1:1998 RFI, EMI and ESD protection
Electrical protection	Reverse polarity, over-voltage and short circuit protected
Shock	1000 g's according to IEC 60068-2-27
Vibration	20 g's according to IEC 60068-2-6
Weight	Approximately 12 oz.

* Unregulated

ORDERING INFORMATION									
SERIES	623	Stainless steel threaded connection		624*	316 Stainless steel flush diaphragm				
PRESSURE RANGES	30vac	-30 inHg to 0 psig	30	0 psig to 30 psig	500	0 psig to 500 psig			
	30/30	-30 inHg to 30 psig	60	0 psig to 60 psig	1000	0 psig to 1,000 psig			
	30/60	-30 inHg to 60 psig	100	0 psig to 100 psig	1500	0 psig to 1,500 psig			
	30/100	-30 inHg to 100 psig	200	0 psig to 200 psig	2000	0 psig to 2,000 psig			
	15	0 psig to 15 psig	300	0 psig to 300 psig	3000	0 psig to 3,000 psig			
				5000	0 psig to 5,000 psig	6000	0 psig to 6,000 psig		
				8000	0 psig to 8,000 psig	10000	0 psig to 10,000 psig		
				15000	0 psig to 15,000 psig	15000	0 psig to 15,000 psig		
				3000	0 psia to 3,000 psig	15A	0 psia to 15 psia		
				5000	0 psia to 5,000 psig	100A	0 psia to 100 psia		
				Note: 624 Series is available for pressure ranges up to 0 psig to 8,000 psig					
ACCURACY	1	±0.25% full scale (BFSL)							
OUTPUT SIGNALS	1	4 mA to 20 mA, 2-wire		3	1 Vdc to 5 Vdc, 3-wire, low power		31	0.5 Vdc to 4.5 Vdc, 3-wire, low power	
PROCESS CONNECTIONS	2	1/4" NPT male		11	G 1/2 B**				
	8	1/2" NPT male		13	G 1 B (624 Series only, <30 psig)				
ELECTRICAL CONNECTION	6	1/2" NPT male conduit with 6' integral cable							
OPTION	ST8	Threaded Orifice (623 Series only)							

Please consult your local NOSHOK Distributor or NOSHOK, Inc. for availability and delivery information.

*Hastelloy flush diaphragm available upon request.

** 624 Series only, G 1/2 B Flush (≥ 30 psig).

EXAMPLE

Series 623 Series
 Pressure range 0 psig to 500 psig
 Accuracy ±0.25% full scale (BFSL)
 Output signal 4 mA to 20 mA, 2-wire
 Process connection 1/2" NPT Male
 Electrical connection 1/2" NPT Male conduit with 6' integral cable
 Option Threaded Orifice

623 - 500 - 1 - 1 - 8 - 6 - ST8

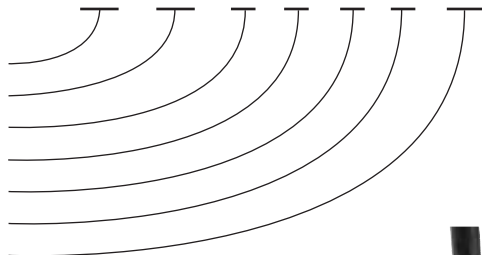

Front flush process connections

For ranges 0 psi to 30 psi through 0 psi to 8,000 psi

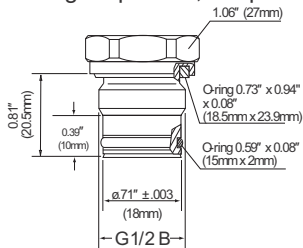

For ranges 0 to 30 psi and below

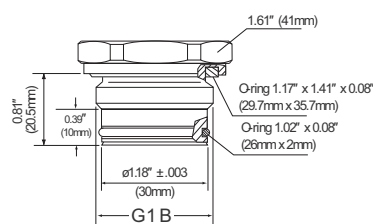

Flush corresponding port weld-on adapters

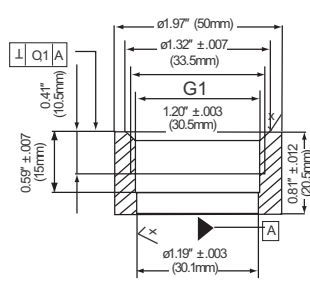
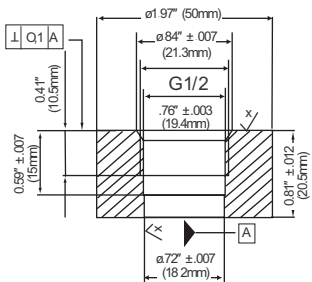

2-WIRE WIRING

+ Supply	Brown
+ Output	Green

3-WIRE WIRING

+ Supply	Brown
Common	Green
+ Output	White



625/626 SERIES

- Low pressure ranges for vapor recovery applications, vacuum and compound ranges through 0 psig to 15,000 psig; absolute ranges from 0 psia to 15 psia through 0 psia to 300 psia
- Current output
- 316 and 14-4PH stainless steel wetted parts
- Factory Mutual and Canadian Standards Association approved
- CE compliant to suppress RFI, EMI and ESD
- NSI/ISA-12.27.01-2003 approved single seal

APPLICATIONS

- Chemical processing
- Gas pressure measurement
- Oil field & offshore
- Mining
- Vapory recovery systems
- Well head measurement

NOSHOK 625 and 626 Series transmitters are Factory Mutual and Canadian Standards Association approved for use in hazardous location applications as follows: Intrinsically Safe, entity approval for Class I, II and III, Division 1, Groups A, B, C, D, E, F and G; and Class I, Zone 0 Aex ia IIC Dust Ignition-proof for Class II and III, Division 2, Groups F and G Non-incendive for Class I, Division 2, Groups A, B, C and D. CE compliant with pressure equipment directive 97/23EC. ANSI/ISA-12.27.01-2003, Approved single seal.

SPECIFICATIONS

Output signal	4 mA to 20 mA, 2-wire
Pressure ranges	Vacuum through 0 psig to 15,000 psig Absolute from 0 psia to 15 psia through 0 psia to 300 psia
Accuracy	±0.25% full scale (BFSL); optional ±0.125% full scale (BFSL) (Includes the effects of non-linearity, hysteresis, non-repeatability, zero point and full scale errors)
Stability	≤ ±0.2% full scale for 1 year, non-accumulating
Adjustment	± 10% full scale for zero and span
Response time	≤ 1 ms (between 10% and 90% full scale)
Pressure cycle limit	150 Hz
Durability	> 100,000,000 full scale cycles
Temperature ranges	Compensated 32 °F to 176 °F (0 °C to 80 °C) Zero effect is ±0.011% full scale/ °F Span effect is ±0.011% full scale/ °F Media -4 °F to 185 °F (-20 °C to 85 °C) Ambient -4 °F to 176 °F (-20 °C to 80 °C) Storage -22 °F to 221 °F (-30 °C to 105 °C)
Power requirement*	10 Vdc to 30 Vdc (4 mA to 20 mA, 2-wire)
Load limitations	≤ (VPower-10)/0.020 Amp
Proof pressure	3.5 times full scale for ranges 0 psi to 5 psi through 0 psi to 200 psi 2 times full scale for ranges 0 psi to 300 psi through 0 psi to 10,000 psi 1.5 times full scale for 0 psi to 15,000 psi
Burst pressure	4 times full scale for ranges 0 psi to 5 psi through 0 psi to 200 psi 4 times full scale for ranges 0 psi to 300 psi through 0 psi to 10,000 psi 3 times full scale for 0 psi to 15,000 psi
Measuring element	625 Series is 316 stainless steel for ranges up through 0 psi to 300 psi, 316 stainless steel with 17-4PH stainless steel for ≥300 psi; 626 Series is 316 stainless steel with NBR o-ring
Connection	316 stainless steel
Housing material	316 stainless steel
Environmental rating	IP65 to IP67 depending upon electrical connection
Electromagnetic rating	CE compliant to EMC norm EN 61326:1997/A1:1998 RFI, EMI and ESD protection
Electrical protection	Reverse polarity, over-voltage and short circuit protected
Shock	1,000 g's according to IEC 60068-2-27
Vibration	20 g's according to IEC 60068-2-6
Weight	Approximately 7 oz.

* Unregulated

ORDERING INFORMATION										
SERIES	625	Stainless steel threaded connection	626	316 Stainless steel flush diaphragm	626H	Hastelloy flush diaphragm				
PRESSURE RANGES	4/12 oz/in ²	-4 oz/in ² to 12 oz/in ²	30/100	-30 inHg to 100 psig	150	0 psig to 150 psig	5000	0 psig to 5,000 psig	100A	0 psia to 100 psia
	12 oz/in ²	0 oz/in ² to 12 oz/in ²	30/150	-30 inHg to 150 psig	200	0 psig to 200 psig	6000	0 psig to 6,000 psig	150A	0 psia to 150 psia
	16 oz/in ²	0 oz/in ² to 16 oz/in ²	30/200	-30 inHg to 200 psig	300	0 psig to 300 psig	7500	0 psig to 7,500 psig	200A	0 psia to 200 psia
	50 inH ₂ O	0 inH ₂ O to 50 inH ₂ O	3	0 psig to 3 psig	500	0 psig to 500 psig	8000	0 psig to 8,000 psig	300A	0 psia to 300 psia
	100 inH ₂ O	0 inH ₂ O to 100 inH ₂ O	5	0 psig to 5 psig	750	0 psig to 750 psig	10000	0 psig to 10,000 psig		
	30vac	-30 inHg to 0 psig	15	0 psig to 15 psig	1000	0 psig to 1,000 psig	15000	0 psig to 15,000 psig		
	30/15	-30 inHg to 15 psig	30	0 psig to 30 psig	1500	0 psig to 1,500 psig	15A	0 psia to 15 psia		
	30/30	-30 inHg to 30 psig	60	0 psig to 60 psig	2000	0 psig to 2,000 psig	30A	0 psia to 30 psia		
	30/60	-30 inHg to 60 psig	100	0 psig to 100 psig	3000	0 psig to 3,000 psig	60A	0 psia to 60 psia		
	psig = gauge pressure psia = absolute pressure Other ranges available on request			Note: 626 Series is available for pressure ranges up to 0 psig to 8,000 psig						
ACCURACY	1	±0.25% full scale (BFSL)		2	±0.125% full scale (BFSL)					
OUTPUT SIGNAL	1	4 mA to 20 mA, 2-wire								
PROCESS CONNECTIONS	2	1/4" NPT male		11	G 1/2 B**					
	6	9/16" -18 UNF 2B high pressure cone*		13	G 1 B (626 Series only, <30 psig)					
	8	1/2" NPT male		45	SAE J1926-3:7/16-20					
ELECTRICAL CONNECTIONS	1	36" cable (connected to option 8)		14	Hirschmann connector 1/2" NPT conduit - IP65					
	3	6-pin Bendix - IP65		25	M12x1 (4-pin) IP67					
	8	Hirschmann (DIN EN 175301-803 Form A)		36	Integral cable 36" - IP67					
OPTION	ST8	Threaded Orifice (625 Series only)								

Please consult your local NOSHOK Distributor or NOSHOK, Inc. for availability and delivery information.

* Equivalent to F250C Parker Autoclave.
 ** 626 Series only, G 1/2 B Flush (≥ 30 psig).

Series 625 Series

Pressure range 0 psig to 500 psig

Accuracy ±0.25% full scale (BFSL)

Output signal 4 mA to 20 mA, 2-wire

Process connection 1/2" NPT Male

Electrical connection Hirschmann (DIN EN 175301-803 Form A)

Option Threaded Orifice

Integral 36" cable

*6 pin Bendix

*M12 x 1 (4-pin)

Hirschmann with
1/2" NPT Female
ISO 4400 conduit

*Note: mate supplied separately

2-WIRE WIRING

	Hirschmann	Cable	M12	Bendix
+ Supply	1	Red/Brown	1	A
+ Output	2	Black/Green	3	B

NOTE

See 621/622 Series
for G1/2B and G1B
Front Flush Process
Connection Dimensions
pg. 85

Hirschmann

Intrinsically Safe Submersible



627 SERIES

- Ranges from 0 inH₂O to 50 inH₂O through 0 psig to 350 psig
- Current output
- 316 stainless and 17-4PH steel wetted parts
- Factory Mutual and Canadian Standards Association approved
- CE compliant to suppress RFI, EMI and ESD

APPLICATIONS

- Irrigation
- Tank monitoring
- Water & wastewater
- Well head measurement

SPECIFICATIONS

Output signal	4 mA to 20 mA, 2-wire
Pressure ranges	0 inH ₂ O to 50 inH ₂ O through 0 psig to 350 psig
Accuracy	±0.25 % full scale (BFSL); optional ±0.125% full scale (BFSL), for ranges ≥ 150 inH ₂ O (Includes the effects of non-linearity, hysteresis, non-repeatability, zero point and full scale errors)
Stability	≤ ±0.2% full scale for 1 year, non-accumulating
Response time	≤1 ms (between 10% and 90% full scale)
Durability	>100,000,000 full scale cycles
Temperature ranges	Compensated 32 °F to 122 °F (0 °C to 50 °C) Zero effect is ±0.011% full scale/ °F within compensated range Span effect is ±0.011% full scale/ °F within compensated range Media 15 °F to 175 °F (-10 °C to 60 °C) Ambient 15 °F to 122 °F (-10 °C to 50 °C) Storage -30 °F to 175 °F (-34 °C to 60 °C)
Power requirement*	10 Vdc to 30 Vdc (4 mA to 20 mA, 2-wire)
Load limitations	≤ (VPower-10)/0.020 Amp-(0.043 Ω x length of cable in feet)
Proof pressure	2 times range
Burst pressure	3 times range
Measuring element	Diaphragm and cap: 316 stainless steel 17-4PH stainless steel for 0 psig to 350 psig Cable: Polyurethane, optional FEP
Connection	316 stainless steel
Housing material	316 stainless steel
Environmental rating	IP68
Electromagnetic rating	CE compliant to EMC norm EN 61326:1997/A1:1998 RFI, EMI and ESD protection
Electrical protection	Reverse polarity, over-voltage and short circuit protected
Weight	Approximately 7 oz. with standard nosecone - cable extra

* Unregulated

NOSHOK 627 Series transmitters are Factory Mutual and Canadian Standards Association approved for use in hazardous location applications as follows:
Intrinsically Safe, entity approval for Class I, II and III, Division 1, Groups A, B, C, D, E, F and G; and Class I, Zone 0 Aex ia IIC
Dust ignition-proof for Class II and III, Division 1, Groups E, F and G
Non-incendive for Class I, Division 2, Groups A, B, C and D
FMRC 3600, 3610, 3611, 3810 (including supplement #1),
ISA-S12.0. 01, IEC 60529 (including amendment #1).
CE compliant with pressure equipment directive 97/23EC.

ORDERING INFORMATION			
SERIES	627		
PRESSURE RANGES	50inH ₂ O	0 inH ₂ O to 50 inH ₂ O	5 0 psig to 5 psig (11.5 ftH ₂ O)
	100inH ₂ O	0 inH ₂ O to 100 inH ₂ O	10 0 psig to 10 psig (23.1 ftH ₂ O)
	150inH ₂ O	0 inH ₂ O to 150 inH ₂ O	15 0 psig to 15 psig (34.6 ftH ₂ O)
	250inH ₂ O	0 inH ₂ O to 250 inH ₂ O	25 0 psig to 25 psig (57.7 ftH ₂ O)
	400inH ₂ O	0 inH ₂ O to 400 inH ₂ O	30 0 psig to 30 psig (69.2 ftH ₂ O)
			60 0 psig to 60 psig (138.4 ftH ₂ O)
	psig = gauge pressure	inH ₂ O = inches of water	ftH ₂ O = feet of water Other ranges available on request.
ACCURACIES	1	±0.25% full scale (BFSL)	2 ±0.125% full scale (BFSL) on ≥ 150 inH ₂ O
OUTPUT SIGNAL	1	4 mA to 20 mA, 2-wire	
PROCESS CONNECTIONS	N	Stainless steel nosecone	W Stainless steel weighted nosecone (1.1 lb.)
	T	NPT adapter, 1/2" NPT male outer thread with 1/4" NPT female inner thread attached to transmitter process connection with straight thread and o-ring seal	
ELECTRICAL CONNECTIONS	XX	Standard Polyurethane cable	
	38-XX	Optional FEP cable	NOTE: XX = length of cable in feet
OPTIONS	CBC	Cable Clamp	FE Filter Element
	DC	Desiccant Cartridge	JB Cable Junction Box

Please consult your local NOSHOK Distributor or NOSHOK, Inc. for availability and delivery information.

EXAMPLE

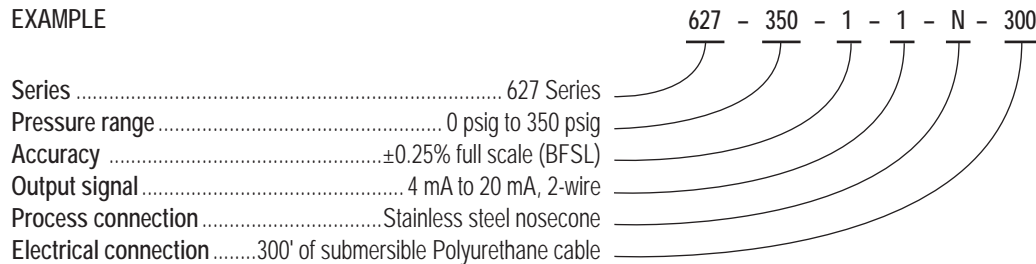

Weighted Nosecone

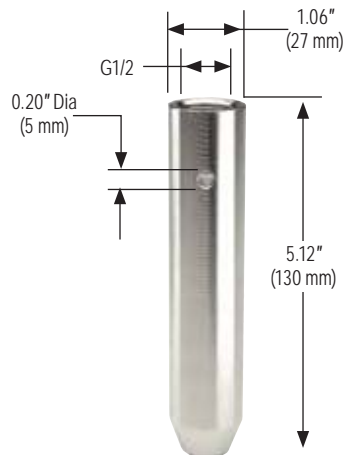

NPT Adapter

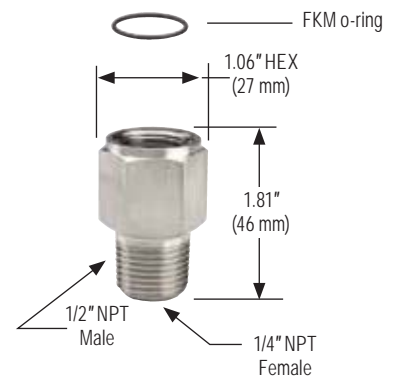

2-WIRE WIRING

+ Supply	Brown
+ Output	Green

628 SERIES

- Ranges from 0 psig to 5,000 psig through 0 psig to 20,000 psig
- Current output
- Inconel X-750 wetted parts
- Canadian Standards Association approved
- NACE MR0175/ISO 15156 compliant
- Every sensor comes with a Certificate of Calibration
- Certifications pending:
 - Factory Mutual
 - ATEX
 - CE



Shown with optional Electrical Connector Cage

APPLICATIONS

- Acidizing
- Choke & kill manifold
- Fracturing & cementing
- Mud logging & mud pumps
- Oil field & offshore
- Well head measurement

NOSHOK 628 Series transmitters are Canadian Standards Association approved for use in hazardous location applications as follows:

Intrinsically Safe Class I, DIV 1, Groups A,B,C,D, -40°C, Tamb<+85°C T4, Class II, DIV 1, Groups E,F,G, Class III, Class I, Zone 0 AEx/Ex ic IIC T4.

Non-Incendive Class I, DIV 2, Groups A,B,C,D, -40°C, Tamb<+85°C T4, Class II, DIV 2, Groups F,G, Class III, Class I, Zone 2 AEx/Ex ic IIC T4.

SPECIFICATIONS

Output signal	4 mA to 20 mA, 2-wire
Pressure ranges	0 psig to 5,000 psig through 0 psig to 20,000 psig
Accuracy	±0.25% full scale (BFSL) (Includes the effects of non-linearity, hysteresis, non-repeatability, zero point and full scale errors)
Stability	≤ ±0.2% full scale for 1 year, non-accumulating
Response time	< 2 m/s
Durability	> 10,000,000 full scale cycles
Temperature ranges	Compensated 40 °F to 140 °F (5 °C to 60 °C) Zero effect is ±0.01% full scale/ °F Span effect is ±0.01% full scale/ °F Media -40 °F to 185 °F (-40 °C to 85 °C) Ambient -40 °F to 185 °F (-40 °C to 85 °C) Storage -40 °F to 185 °F (-40 °C to 85 °C)
Power requirement*	10 Vdc to 28 Vdc
Load limitations	≤ (VPower-10)/0.020 Amp
Proof pressure	1.5 times full scale (22,500 psi maximum)
Burst pressure	3 times full scale (22,500 psi maximum)
Measuring element	Inconel X-750
Connection	Inconel X-750
Housing material	316 stainless steel
Environmental rating	IP67 depending upon electrical connection
Electromagnetic rating	CE compliant to EMC norm EN 61326:1997/A1:1998 RFI, EMI and ESD protection
Electrical protection	Reverse polarity, over-voltage and short circuit protected
Shock	100 g's according to IEC 60068-2-27
Vibration	15 g's according to IEC 60068-2-6
Weight	Approximately 6 lb.

* Unregulated

ORDERING INFORMATION										
SERIES	628									
PRESSURE RANGES	5000	0 psig to 5,000 psig	6000	0 psig to 6,000 psig	10000	0 psig to 10,000 psig	15000	0 psig to 15,000 psig	20000	0 psig to 20,000 psig
ACCURACY	1 ±0.25% full scale (BFSL)									
OUTPUT SIGNAL	1 4 mA to 20 mA, 2-wire									
WIRING CODE	A		E		H*					
(See Wiring Code Schematics below)	C		F							
	D		G							
PROCESS CONNECTIONS	14 2" Wing union (#1502)									
ELECTRICAL CONNECTIONS	3 6-pin Bendix (MIL-C-26482)			44 4-pin (MIL-C-5015)						
	36 Integral cable with gland									
OPTION	CH Carrying Handle			EC Electrical Connector Cage						

Please consult your local NOSHOK Distributor or NOSHOK, Inc. for availability and delivery information.

* H is the standard wiring code.

EXAMPLE

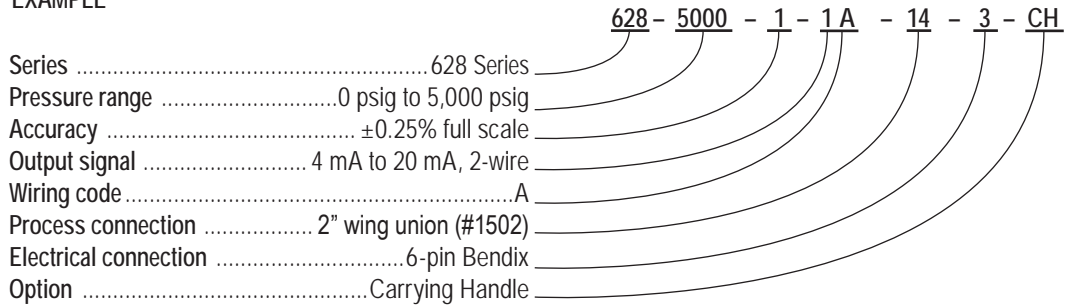

WIRING CODE SCHEMATICS

A	Pin A	+ Supply	E	Pin A	+ Supply	G	Pin B	+ Supply
	Pin B	- Output		Pin B	- Output		Pin C	- Output
	Pin E	Ground		Pin E	+ Shunt Cal		Pin D	Ground
C	Red	+ Supply		Pin F	- Shunt Cal	H*	Pin A	+ Supply
	Black	- Output		F	Pin A		+ Supply	Pin B
D	Red	+ Supply			Pin B		- Output	Pin D
	Black	- Output	Pin C		+ Shunt Cal		Pin E	+ Shunt Cal
	White	- Shunt Cal	Pin D		- Shunt Cal		Pin F	- Shunt Cal
	Green	Ground	Pin E		Ground			

* H is the standard wiring code.





11 SERIES

- Ranges from vacuum through 0 psig to 400 psig
- Current and voltage outputs available
- 316 stainless steel wetted parts
- Can be cleaned-in-place (CIP) or steamed-in-place (SIP)
- Meets 3A requirements for the food and beverage, dairy, pharmaceutical and biotechnology industries
- ASME BPE compliant
- CE compliant to suppress RFI, EMI and ESD

SPECIFICATIONS

Output signals	4 mA to 20 mA 2-wire, 0 Vdc to 5 Vdc 3-wire, 1 Vdc to 5 Vdc 3-wire, 1 Vdc to 6 Vdc 3-wire, 0 Vdc to 10 Vdc, 3-wire, 1 Vdc to 11 Vdc 3-wire
Pressure ranges	Vacuum through 0 psig to 400 psig
Accuracy	±0.25% full scale (BFSL); Optional ±0.125% full scale (BFSL); (Includes the effects of non-linearity, hysteresis, non-repeatability, zero point and full scale errors)
Stability	±0.2% full scale for 1 year, non-accumulating
Adjustment	±10% full scale for zero and span
Response time	< 10 ms
Pressure cycle limit	150 Hz
Durability	> 100,000,000 full scale cycles
Temperature ranges	Compensated 32 °F to 175 °F (0 °C to 80 °C) Effect ±0.01%/°F for zero and span Media -40 °F to 300 °F (-40 °C to 150 °C) Ambient -40 °F to 176 °F (-40 °C to 80 °C) Storage -40 °F to 212 °F (-40 °C to 100 °C)
Power requirement*	10 Vdc to 30 Vdc (4 mA to 20 mA, 2-wire, 0 Vdc to 5 Vdc, 3-wire, 1 Vdc to 5 Vdc, 3-wire, 1 Vdc to 6 Vdc, 3-wire) 14 Vdc to 30 Vdc (0 Vdc to 10 Vdc, 3-wire, Vdc to 11 Vdc, 3-wire)
Load limitations	≤ (VPower -10)/0.020 Amp for 4 mA to 20 mA output ≤ 5,000 Ω for 1 Vdc to 5 Vdc output ≤ 10,000 Ω for 0 Vdc to 10 Vdc output ≤ 4,500 Ω for 0.5 Vdc to 4.5 Vdc output
Proof pressure	3 times full scale for 0 psig to 2 psig through 0 psig to 200 psig 1.75 times full scale for 0 psig to 300 psig through 0 psig to 400 psig
Burst pressure	3.8 times full scale for 0 psig to 2 psig through 0 psig to 200 psig 4 times full scale for 0 psig to 300 psig through 0 psig to 400 psig
Measuring element	316 stainless steel
Connection	316 stainless steel
Housing material	316 stainless steel
Environmental rating	IP65
Electromagnetic rating	CE compliant to EMC norm EN 61326:1997/A1:1998 RFI, EMI and ESD protection
Electrical protection	Reverse polarity, overvoltage and short circuit protection
Shock	1,000 g's according to IEC 60068-2-27
Vibration	15 g's according to IEC 60068-2-6
Weight	Approximately 1.1 lb.

* Unregulated

Diaphragm seal must be installed facing downward or in a vertical position for drainability. Do not install diaphragm seal facing in an upward position.

APPLICATIONS

- Food & beverage processing
- Pasteurization systems
- Pharmaceutical
- Medical

ORDERING INFORMATION				
SERIES	110			
CLAMP SIZES	12 1-1/2"	16 2"		
SEAL FILL FLUID	4 FFL77 White oil	Other food grade quality fill fluids available — please consult factory		
TRANSDUCER	615 615 Series transducer			
ACCURACIES	1 ±0.25% full scale (BFSL)	2 ±0.125% full scale		
PRESSURE RANGES	01 -30 inHg to 0 psig	16 -30 inHg to 150 psig	37 0 psig to 10 psig	52 0 psig to 150 psig
	04 -30 inHg to 15 psig	19 -30 inHg to 200 psig	40 0 psig to 15 psig	58 0 psig to 200 psig
	07 -30 inHg to 30 psig	22 -30 inHg to 300 psig	43 0 psig to 30 psig	61 0 psig to 300 psig
	10 -30 inHg to 60 psig	31 0 psig to 100 inH ₂ O	46 0 psig to 60 psig	64 0 psig to 400 psig
	13 -30 inHg to 100 psig	34 0 psig to 5 psig	49 0 psig to 100 psig	
	OUTPUT SIGNALS	1 4 mA to 20 mA, 2-wire	3 1 Vdc to 5 Vdc, 3-wire	5 0 Vdc to 10 Vdc, 3-wire
	2 0 Vdc to 5 Vdc, 3-wire	4 1 Vdc to 6 Vdc, 3-wire	6 1 Vdc to 11 Vdc, 3-wire	
ELECTRICAL CONNECTIONS	1 36" Cable attached to Hirschmann	14 Hirschmann connection with ISO 4400 1/2" NPT conduit		
	3 6-pin Bendix	25 M12 X 1 (4-pin)		
	8 Hirschmann (DIN EN 175301-803 form A)	36 Integral 36" cable		

Please consult your local NOSHOK Distributor or NOSHOK, Inc. for availability and delivery information.

EXAMPLE

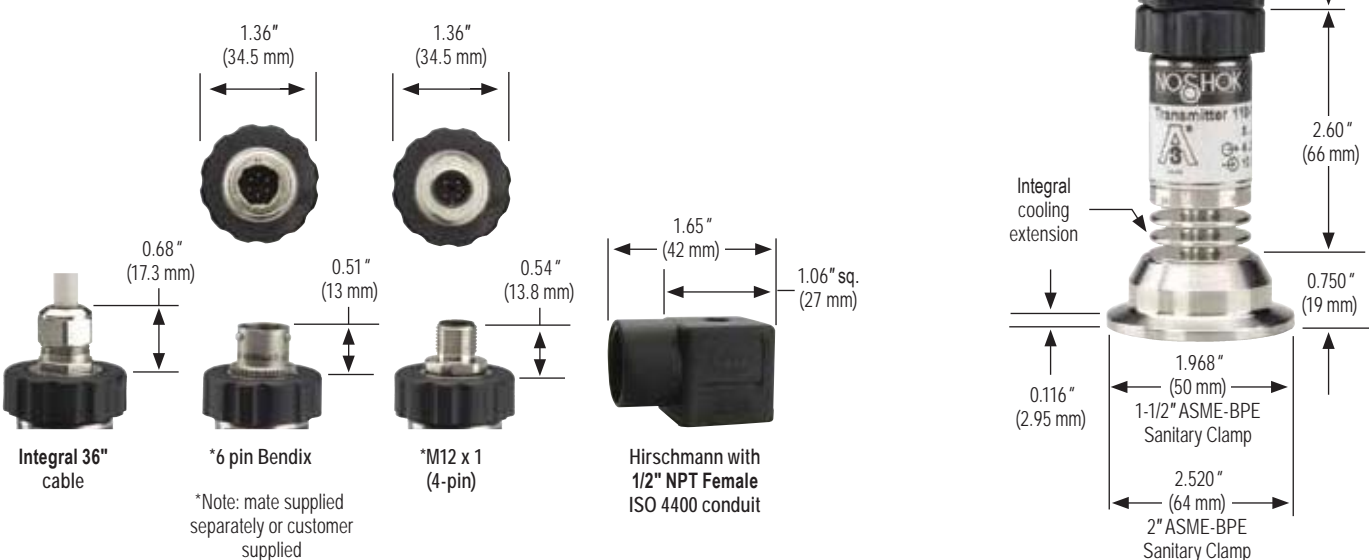
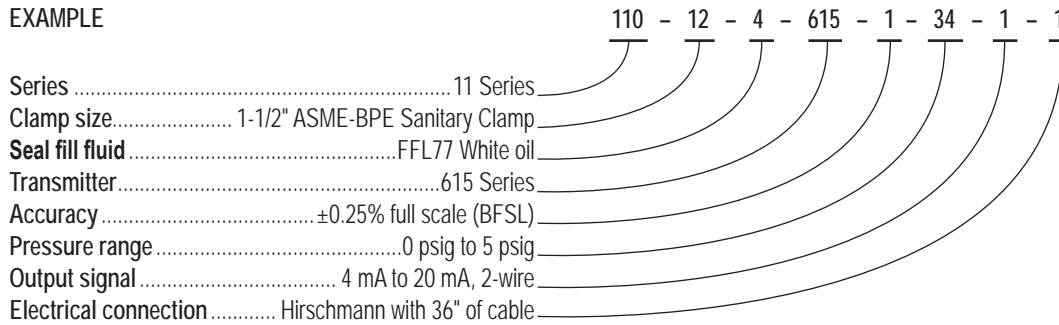

2-WIRE WIRING

	Hirschmann	Cable	M12	Bendix
+ Supply	1	Red	1	A
+ Output	2	Black	3	B

3-WIRE WIRING

	Hirschmann	Cable	M12	Bendix
+ Supply	1	Red	1	A
Common	2	Black	3	B
+ Output	3	White	4	C



21 SERIES

- Ranges from 0 psig to 1,000 psig through 0 psig to 15,000 psig
- Current and voltage outputs available
- 316 stainless steel wetted parts
- Can be cleaned-in-place (CIP) or steamed-in-place (SIP)
- Meets 3A requirements for the food and beverage, dairy, pharmaceutical and biotechnology industries
- ASME BPE compliant
- CE compliant to suppress RFI, EMI and ESD

APPLICATIONS

- High pressure processing
- Pasteurization systems
- Homogenization systems

SPECIFICATIONS

Output signals	4 mA to 20 mA 2-wire, 0 Vdc to 5 Vdc 3-wire, 1 Vdc to 5 Vdc 3-wire, 1 Vdc to 6 Vdc 3-wire, 0 Vdc to 10 Vdc, 3-wire, 1 Vdc to 11 Vdc 3-wire
Pressure ranges	0 psig to 1,000 psig through 0 psig to 15,000 psig
Accuracy	±0.25% full scale (BFSL); ±0.125% full scale (optional)
Stability	≤ ±0.2% full scale for 1 year, non-accumulating
Adjustment	±10% full scale for zero and span
Response time	≤ 1 ms (between 10% and 90% full scale)
Pressure cycle limit	150 Hz
Durability	> 100,000,000 full scale cycles
Temperature ranges	Compensated 32 °F to 176 °F (0 °C to 80 °C) Effect ±0.017% full scale/ °F for zero and span Media -22 °F to 212 °F (-30 °C to 100 °C) Ambient -40 °F to 185 °F (-40 °C to 85 °C) Storage -40 °F to 212 °F (-40 °C to 100 °C)
Power requirement*	10 Vdc to 30 Vdc (4 mA to 20 mA, 2-wire, 0 Vdc to 5 Vdc, 3-wire, 1 Vdc to 5 Vdc, 3-wire, 1 Vdc to 6 Vdc, 3-wire) 14 Vdc to 30 Vdc (0 Vdc to 10 Vdc, 3-wire, 1 Vdc to 11 Vdc, 3-wire)
Load limitations	≤ (Vpower supply -10)/0.020 Amp
Proof pressure	1.75 times full scale for 0 psig to 300 psig through 0 psig to 10,000 psig 1.5 times full scale for 0 psig to 15,000 psig
Burst pressure	4 times full scale for 0 psig to 300 psig through 0 psig to 10,000 psig 3 times full scale for 0 psig to 15,000 psig
Measuring element	316 stainless steel for vacuum through 300 psi; 17-4PH stainless steel for ≥500 psi
Connection	316 stainless steel
Housing material	316 stainless steel
Environmental rating	IP65
Electromagnetic rating	CE compliant to EMC norm EN 61326:1997/A1:1998 RFI, EMI and ESD protection
Electrical protection	Reverse polarity, over-voltage and short circuit protection
Shock	1000 g's according to IEC 60068-2-27
Vibration	30 g's according to IEC 60068-2-6
Weight	Approximately 3.5 oz.

* Unregulated

Diaphragm seal must be installed facing downward or in a vertical position for drainability.
Do not install diaphragm seal facing in an upward position.

ORDERING INFORMATION				
SERIES	210			
CLAMP SIZE	42 1-1/8" flange			
SEAL FILL FLUID	4 FFL77 White oil (Other fill fluids available — please consult factory)			
TRANSDUCER	615 615 Series transducer			
ACCURACIES	1 ±0.25% full scale (BFSL)	2 ±0.125% full scale (BFSL)		
PRESSURE RANGES	73 0 psig to 1,000 psig	79 0 psig to 2,000 psig	85 0 psig to 5,000 psig	91 0 psig to 10,000 psig
	76 0 psig to 1,500 psig	82 0 psig to 3,000 psig	88 0 psig to 6,000 psig	94 0 psig to 15,000 psig
OUTPUT SIGNALS	1 4 mA to 20 mA, 2-wire	3 1 Vdc to 5 Vdc, 3-wire	5 0 Vdc to 10 Vdc, 3-wire	
	2 0 Vdc to 5 Vdc, 3-wire	4 1 Vdc to 6 Vdc, 3-wire	6 1 Vdc to 11 Vdc, 3-wire	
ELECTRICAL CONNECTIONS	1 36" Cable attached to Hirschmann	14 Hirschmann connection with ISO 4400 1/2" NPT conduit		
	3 6-pin Bendix	25 M12 X 1 (4-pin)		
	8 Hirschmann (DIN EN 175301-803 Form A)	36 Integral 36" cable		

Please consult your local NOSHOK Distributor or NOSHOK, Inc. for availability and delivery information.

EXAMPLE

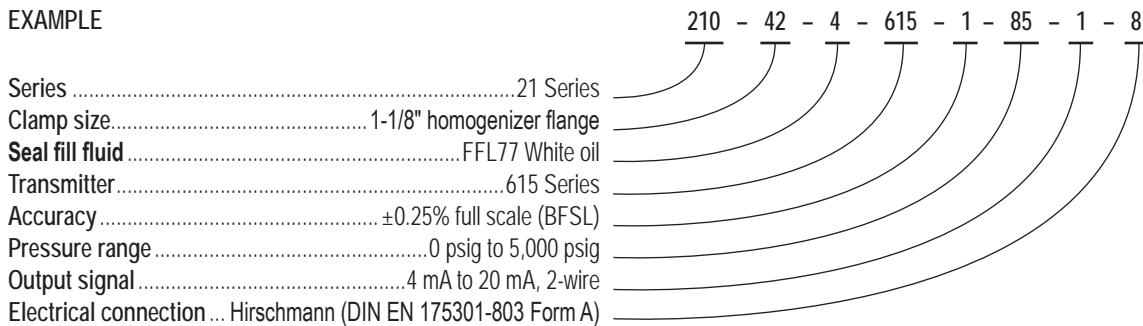

2-WIRE WIRING

	Hirschmann	Cable	M12	Bendix
+ Supply	1	Red	1	A
+ Output	2	Black	3	B

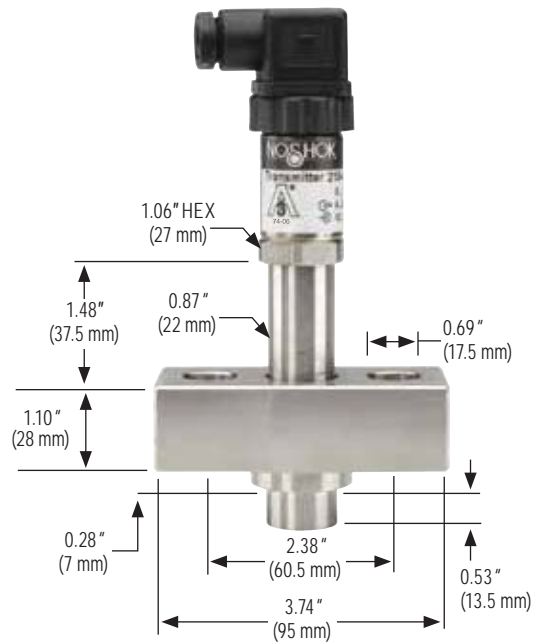

3-WIRE WIRING

	Hirschmann	Cable	M12	Bendix
+ Supply	1	Red	1	A
Common	2	Black	3	B
+ Output	3	White	4	C

(Custom flange dimensions to your specification — please consult factory)

Mechanical Miniature Low Pressure



N.C.



N.O.

100 SERIES

- Switch adjustment ranges from 15 psig to 30 psig through 15 psig to 150 psig
- Standard brass with NBR diaphragm wetted parts
- 1 SPST N.O. or N.C. contact

APPLICATIONS

- Hydraulics & pneumatics
- Pumps & compressors
- Tank monitoring
- Leak detection
- Water management

SPECIFICATIONS

Switching parameters	
Number	1
Function	SPST N.O. or N.C. contact
Contact rating	Up to 42 Vdc -2A
Non-repeatability	5% of the adjusted value
Contact material	Silver-plated, optional gold-plated
Frequency	Max. 100 cycles/min
Pressure ranges	
Pressure ranges	15 psig to 30 psig through 15 psig to 150 psig
Switch adjustment	
Switch point	Full scale
Hysteresis	< 10% of the adjusted value
Durability	
Durability	>1,000,000 cycles
Temperature ranges	
Media	-13 °F to 185 °F (-25 °C to 85 °C)
Ambient	-13 °F to 185 °F (-25 °C to 85 °C)
Storage	-13 °F to 185 °F (-25 °C to 85 °C)
Proof pressure	
Proof pressure	Full scale
Measuring element	
Measuring element	NBR diaphragm 1/8" NPT Male brass
Housing material	
Housing material	Brass, optional stainless steel
Environmental rating	
Environmental rating	IP65
Weight	
Weight	Approximately 0.07 lb

ORDERING INFORMATION		
SERIES	100	
SWITCH FUNCTIONS	1 1 Normally open	2 1 Normally closed
PROCESS CONNECTION	1 1/8" NPT male	
SWITCH ADJUSTMENT RANGES	5/30 5 psig to 30 psig	15/150 15 psig to 150 psig
ELECTRICAL CONNECTION	4 6.3 mm spade terminals	
SWITCH POINT (if required)	Specify pressure	

Please consult your local NOSHOK Distributor or NOSHOK, Inc. for availability and delivery information.

EXAMPLE

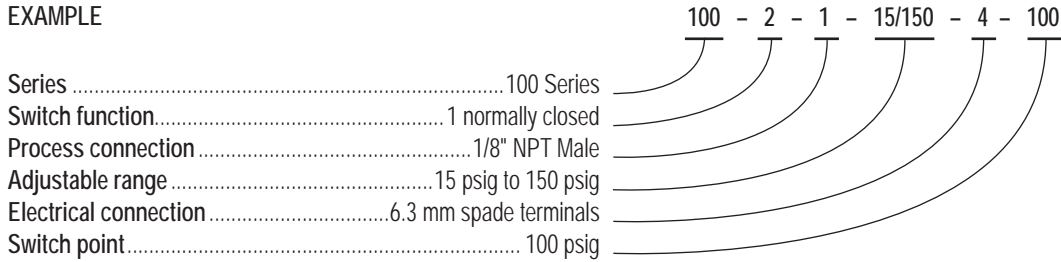

Switching Output Schematic

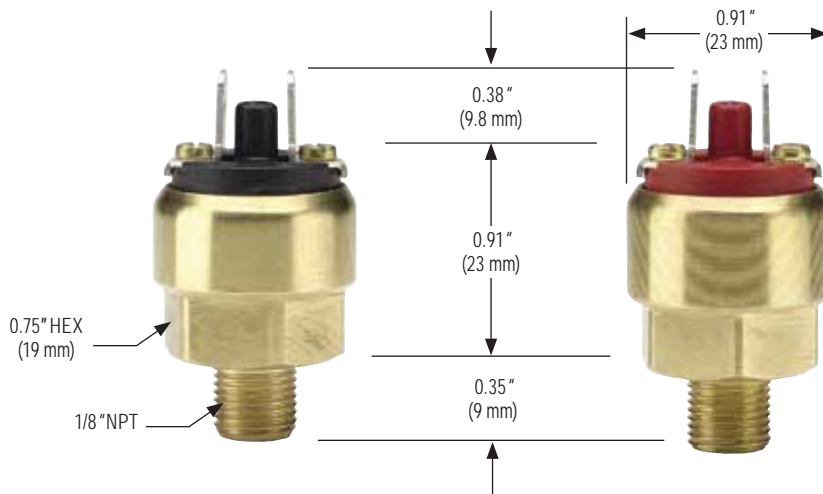



200 SERIES

- Switch adjustment ranges from 3 psig to 30 psig through 450 psig to 4,600 psig
- Zinc-plated steel with NBR diaphragm (< 225 psig); steel piston with NBR seal (> 225 psig) wetted parts
- SPDT single changeover contact configuration
- RoHS compliant

APPLICATIONS

- Hydraulics & pneumatics
- Pumps & compressors
- Tank monitoring
- Leak detection
- Water management

SPECIFICATIONS

Switching parameters	
Number	1
Function	SPDT, micro switch with silver-plated contacts, gold plated contacts available on request
Contact rating	Up to 28 Vdc 2A Up to 50 Vac 4A
Non-repeatability	±2% of full scale adjustment range
Contact material	Silver-plated
Frequency	Max. 100 cycles/min
Media	Diaphragm type, compressed air or not corrosive liquids Piston type, self lubricating fluids such as hydraulic oil or grease
Pressure ranges	
	3 psig to 30 psig through 450 psig to 4,600 psig Diaphragm type: 870 psi max.; piston type: 5,000 psi max.
Switch adjustment	
Switch point	Full scale
Hysteresis	Diaphragm type, ≤ 10% of full scale adjustment range, minimum 100 psig, Piston type, maximum 15% of full scale adjustment range
Durability	
	>1,000,000 cycles
Temperature ranges	
	Media -4 °F to 176 °F (-20 °C to 80 °C) Ambient -4 °F to 176 °F (-20 °C to 80 °C) Storage -4 °F to 176 °F (-20 °C to 80 °C)
Proof pressure	
	870 psig or 5,000 psig depending on adjustment range
Measuring element	
	NBR diaphragm < 225 psig; Steel piston with NBR seal > 225 psig 1/4" NPT zinc-plated steel
Housing material	
	Zinc-plated steel
Environmental rating	
	Spade terminals IP00 Cable connection IP67
Weight	
	Approximately 0.2 lb.

ORDERING INFORMATION				
SERIES	200			
SWITCH FUNCTION	1	Single changeover contact (SPDT)		
PROCESS CONNECTION	2	1/4" NPT male		
SWITCH ADJUSTMENT RANGES <i>(Max. working pressure)</i>	3/30	3 psig to 30 psig (870 psig)	150/1700	150 psig to 1,700 psig (5,000 psig)
	7/115	7 psig to 115 psig (870 psig)	150/2300	150 psig to 2,300 psig (5,000 psig)
	15/225	15 psig to 225 psig (870 psig)	300/2900	300 psig to 2,900 psig (5,000 psig)
	150/425	150 psig to 425 psig (5,000 psig)	300/3600	300 psig to 3,600 psig (5,000 psig)
	150/1150	150 psig to 1,150 psig (5,000 psig)	450/4600	450 psig to 4,600 psig (5,000 psig)
ELECTRICAL CONNECTIONS	4	6.3 mm Spade terminals	36	18" Integral cable

Please consult your local NOSHOK Distributor or NOSHOK, Inc. for availability and delivery information.

EXAMPLE

Series200 Series
 Switch function.....Single changeover contact
 Process connection.....1/4" NPT Male
 Adjustable range.....150 psig to 425 psig
 Electrical connection.....6.3 mm spade terminals

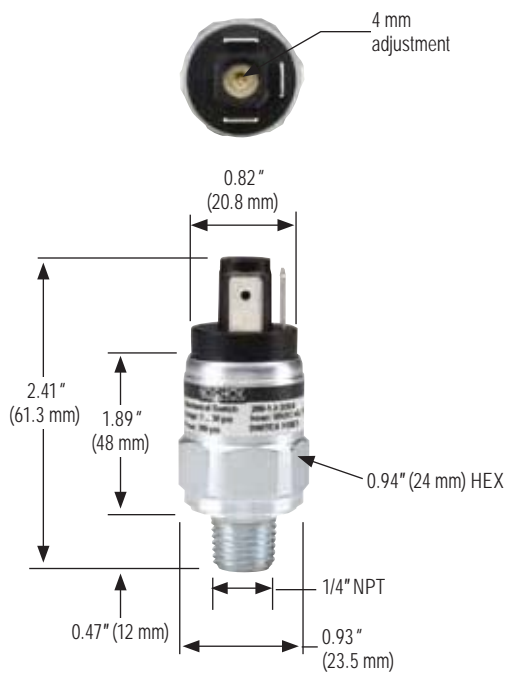
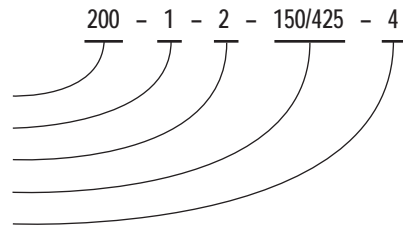

Switching Output Schematic

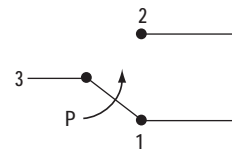



300 SERIES

- Switch adjustment ranges from 3 psig to 30 psig through 450 psig to 4,600 psig
- Standard zinc-plated steel with NBR diaphragm (< 225 psig); steel piston with NBR seal (> 225 psig) wetted parts
- SPDT single changeover contact configuration
- RoHS compliant

SPECIFICATIONS

Switching parameters	
Number	1
Function	SPDT, micro switch
Contact rating	Up to 28 Vdc 2A Up to 125 Vac 4A Up to 250 Vac 4A
Non-repeatability	±2% of full scale adjustment range
Contact material	Silver-plated
Frequency	Max. 100 cycles/min
Media	Diaphragm type, compressed air or not corrosive liquids Piston type, self lubricating fluids such as hydraulic oil or grease
Pressure ranges	
	3 psig to 30 psig through 450 psig to 4,600 psig Diaphragm type: 870 psi max.; Piston type: 5,000 psi max.
Switch adjustment	
Switch point	Full scale
Hysteresis	Adjustable, see Charts below
Durability	>1,000,000 cycles
Temperature ranges	
	Media -4 °F to 176 °F (-20 °C to 80 °C) Ambient -4 °F to 176 °F (-20 °C to 80 °C) Storage -4 °F to 176 °F (-20 °C to 80 °C)
Proof pressure	870 psig or 5,000 psig depending on adjustment range
Measuring element	NBR diaphragm < 225 psig; steel piston with NBR seal > 225 psig 1/4" NPT zinc-plated steel standard connection, others available on request
Housing material	Zinc-plated steel
Environmental rating	IP65
Weight	Approximately 0.2 lb.

APPLICATIONS

- Hydraulics & pneumatics
- Pumps & compressors
- Tank monitoring
- Leak detection
- Water management

Adjustable Hysteresis (piston type)

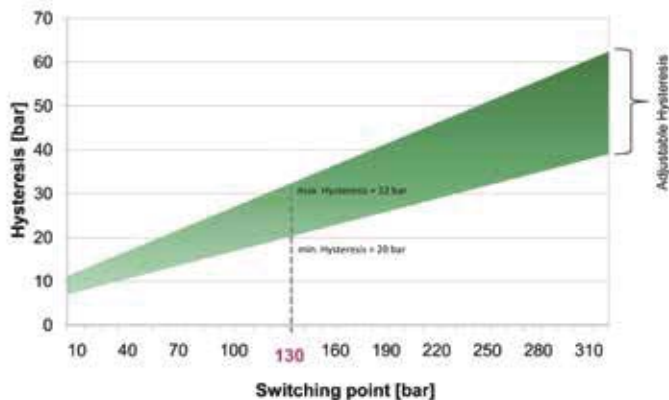

Adjustable Hysteresis (membrane type)

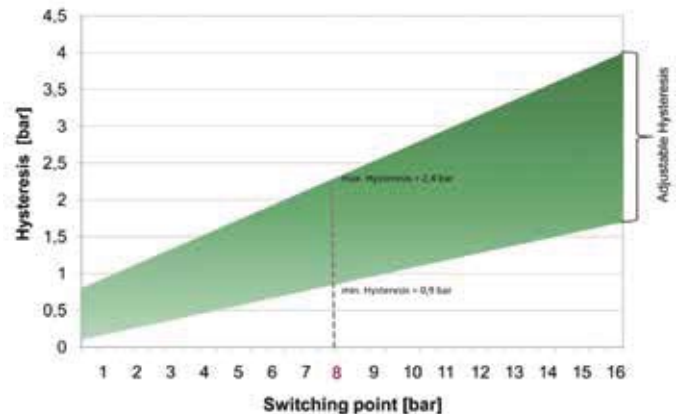

ORDERING INFORMATION					
SERIES	300				
SWITCH FUNCTION	1 Single changeover contact, SPDT				
PROCESS CONNECTION	2 1/4" NPT male				
SWITCH ADJUSTMENT RANGES <i>(Max. working pressure)</i>	3/30	3 psig to 30 psig (870 psig)	150/1700	150 psig to 1,700 psig (5,000 psig)	
	7/115	7 psig to 115 psig (870 psig)	150/2300	150 psig to 2,300 psig (5,000 psig)	
	15/225	15 psig to 225 psig (870 psig)	300/2900	300 psig to 2,900 psig (5,000 psig)	
	150/425	150 psig to 425 psig (5,000 psig)	300/3600	300 psig to 3,600 psig (5,000 psig)	
	150/1150	150 psig to 1,150 psig (5,000 psig)	450/4600	450 psig to 4,600 psig (5,000 psig)	
ELECTRICAL CONNECTIONS	1	36" Cable (connected to option 8)	8	Hirschmann (DIN EN 175301-803 form A)	

Please consult your local NOSHOK Distributor or NOSHOK, Inc. for availability and delivery information.

EXAMPLE

Series 300 Series
 Switch function.....Single changeover contact
 Process connection 1/4" NPT Male
 Adjustable range 15 psig to 225 psig
 Electrical connectionHirschmann

300 - 1 - 2 - 15/225 - 8

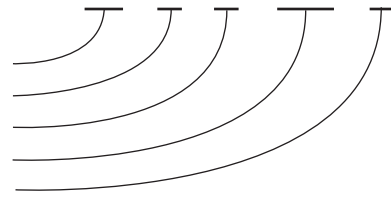

Additional Ordering Information
 Switch Set Point(s) (please specify)

Switching Output Schematic

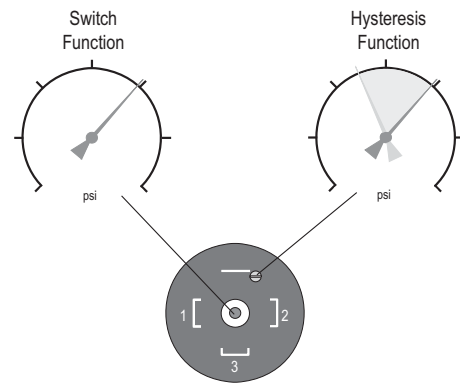
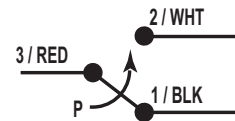



400 SERIES

- Switch adjustment ranges from 0 to 300 psig through 0 to 5,000 psig
- Standard zinc-plated steel with NBR diaphragm (< 225 psig); steel piston with NBR seal (> 225 psig) wetted parts
- SPDT single changeover contact configuration
- CE compliant to suppress RFI, EMI and ESD

APPLICATIONS

- Hydraulics & pneumatics
- Mobile hydraulics
- Power generation
- Pumps & compressors
- Tank monitoring
- Water management

SPECIFICATIONS

Switching parameters	
Number	1
Function	SPDT, micro switch
Contact rating	Up to 28 Vdc Max 4A Up to 250 Vac Max 3A
Non-repeatability	±2% of full scale of adjustment range
Contact material	Silver-plated, self-cleaning
Frequency	Max. 200 cycles/min.
Media	Diaphragm type, compressed air or non-corrosive liquids Piston type, self-lubricating fluids such as hydraulic oil or grease
Pressure ranges	
	0 psig to 300 psig through 0 psig to 5,000 psig Adjustment knob from 3 psig to 4,600 psig dependent on full scale range
Switch adjustment	
Switch point	Full scale
Hysteresis	Diaphragm type, 1% to 11% of adjustment range full scale Piston type, 2% to 8% of adjustment range full scale
Durability	
	>1,000,000 cycles
Temperature ranges	
	Media 14 °F to 176 °F (-10 °C to 80 °C) Ambient 14 °F to 176 °F (-10 °C to 80 °C) Storage 13 °F to 185 °F (-25 °C to 85 °C)
Proof pressure	
	300 psi or 5,000 psi depending on adjustment range
Measuring element	
	NBR diaphragm ≤ 230 psig Stainless steel piston with NBR seal ≥ 500 psig 1/4" NPT and 7/16-20 SAE zinc-plated steel connections standard, others available on request
Housing material	
	Zinc-plated steel
Environmental rating	
	IP65 for Hirschmann IP67 for M12 x 1
Electromagnetic rating	
	CE compliant to EU Standard 73/23/EWG RFI, EMI and ESD protection
Shock	
	30 g's according to IEC 60068-2-27
Vibration	
	10 g's according to IEC 60068-2-6
Weight	
	Approximately 0.66 lb.

ORDERING INFORMATION			
SERIES	400		
SWITCH FUNCTION	1 Single Pole Double Throw (SPDT)		
PROCESS CONNECTIONS*	2	1/4" NPT male	19 G 1/4 B female
	5	1/4" NPT female	45 SAE J1926-3:7/16-20
	10	G 1/4 B male	
SWITCH ADJUSTMENT RANGES (Max. working pressure)	3/30	3 psig to 30 psig (300 psig)	150/1700 150 psig to 1,700 psig (5,000 psig)
	7/115	7 psig to 115 psig (300 psig)	150/2300 150 psig to 2,300 psig (5,000 psig)
	15/225	15 psig to 225 psig (300 psig)	300/2900 300 psig to 2,900 psig (5,000 psig)
	150/425	150 psig to 425 psig (5,000 psig)	300/3600 300 psig to 3,600 psig (5,000 psig)
	150/1150	150 psig to 1,150 psig (5,000 psig)	450/4600 450 psig to 4,600 psig (5,000 psig)
ELECTRICAL CONNECTIONS	1	36" Cable (connected to option 8)	8 DIN EN 175301-803 Form A
	2	M12 x 1 (4-pin)	46 Hirschmann with LED status indicator

Please consult your local NOSHOK Distributor or NOSHOK, Inc. for availability and delivery information.

* Note: Stainless steel connection available, consult factory

EXAMPLE

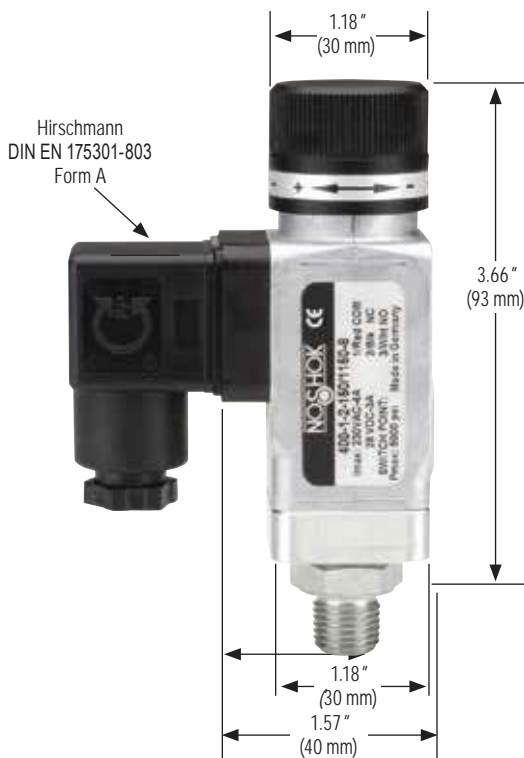
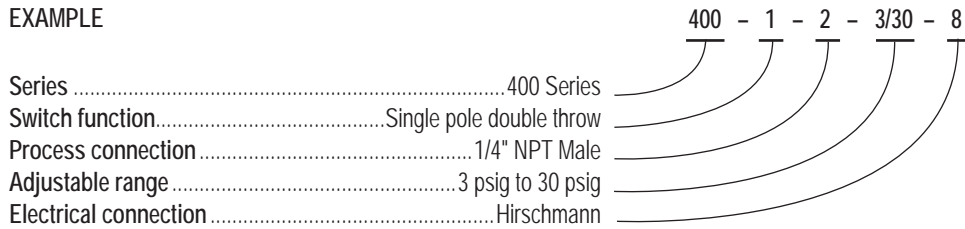

Switching Output Schematic

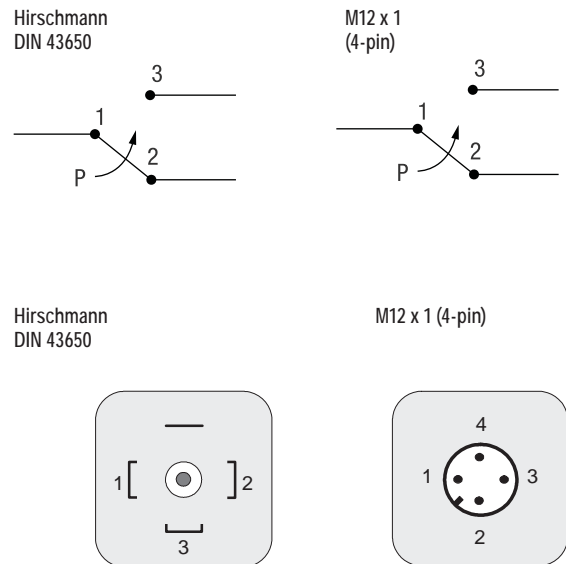



500 SERIES

- Vacuum ranges through 0 psig to 10,000 psig
- Standard copper alloy wetted parts
- Normally open (N.O.) or normally closed (N.C.) switching functions
- CE compliant to suppress RFI, EMI and ESD

APPLICATIONS

- HVAC
- Hydraulics & pneumatics
- Pumps and compressors
- Stamping & forming presses
- Transportation

SPECIFICATIONS

Switching parameters	
Number	1 or 2
Function	N.O. or N.C., p-switching or n-switching
Contact rating	Max. 100 mA (max. 30 Vdc)
Non-repeatability	≤ 1% of full scale
Pressure ranges	
Vacuum ranges through 0 psig to 10,000 psig	
Switch adjustment	
Switch point	Adjustment screw Switching point 5 ...100% of full scale
Hysteresis	≤ 5% of full scale
Durability	
>1,000,000 cycles	
Temperature ranges	
Compensated 32° to 175 °F / 0° to 80 °C Zero ± 0.06% full scale/ °F Span ± 0.06% full scale/ °F Media -5° to 175 °F (-20° to 80 °C) Ambient -5° to 175 °F (-20° to 80 °C) Storage -22° to 175 °F (-30° to 80 °C)	
Power requirement*	
10 Vdc to 30 Vdc	
Proof pressure	
30 psi & lower	5x
60 psi	4x
150 psi & higher	2x
Measuring element	
Copper alloy 316 SS > 600 psi 1/4" NPT brass connection standard	
Housing material	
Brass through 350 psi Aluminum anodized 600 psi and higher	
Environmental rating	
IP65 for Hirschmann IP67 for M12 x 1	
Electromagnetic rating	
CE compliant to EMC norm EN 61326:1997/A1:1998 RFI, EMI and ESD protection	
Weight	
0.2 lb. on ≤400 psi, 0.6 lb. on ≥600 psi	

* Unregulated

ORDERING INFORMATION				
SERIES	500			
SWITCH FUNCTIONS	1 1 N.O. (PNP)	3 2 N.O. (PNP)	5 1 N.O. (NPN)	7 2 N.O. (NPN)
	2 1 N.C. (PNP)	4 2 N.C. (PNP)	6 1 N.C. (NPN)	8 2 N.C. (NPN)
PROCESS CONNECTIONS	1 1/8" NPT male	2 1/4" NPT male		
PRESSURE RANGES	30vac -30 inHg to 0 psig	150 0 psig to 150 psig	1000 0 psig to 1,000 psig	6000 0 psig to 6,000 psig
	15 0 psig to 15 psig	250 0 psig to 250 psig	1500 0 psig to 1,500 psig	7500 0 psig to 7,500 psig
	30 0 psig to 30 psig	350 0 psig to 350 psig	2000 0 psig to 2,000 psig	10000 0 psig to 10,000 psig
	60 0 psig to 60 psig	600 0 psig to 600 psig	3000 0 psig to 3,000 psig	
	100 0 psig to 100 psig	750 0 psig to 750 psig	5000 0 psig to 5,000 psig	
ELECTRICAL CONNECTIONS	1 5' Cable		2 M12x1 (4-pin)	
OPTIONS	1 Additional cable length (specify length) (Available with cable connection only)		BT8 Threaded Orifice Note: M12 mating connectors & cord sets are available as separate options.	

Please consult your local NOSHOK Distributor or NOSHOK, Inc. for availability and delivery information.

EXAMPLE

Series 500 Series
 Switch function..... 2 N.O. (PNP)
 Process connection 1/4" NPT Male
 Adjustable range 0 psig to 750 psig
 Electrical connection M12 x 1 (4-pin)
 Option..... Threaded Orifice

500 - 3 - 2 - 750 - 2 - BT8

Switching Output Schematic

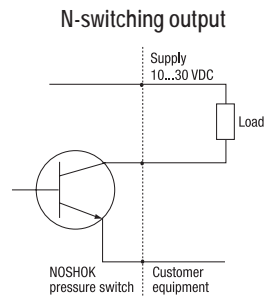
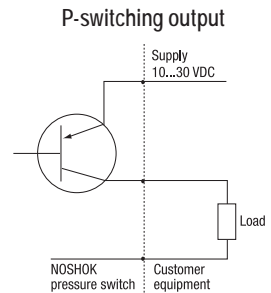

Additional Ordering Information Switch Set Point(s) (please specify)

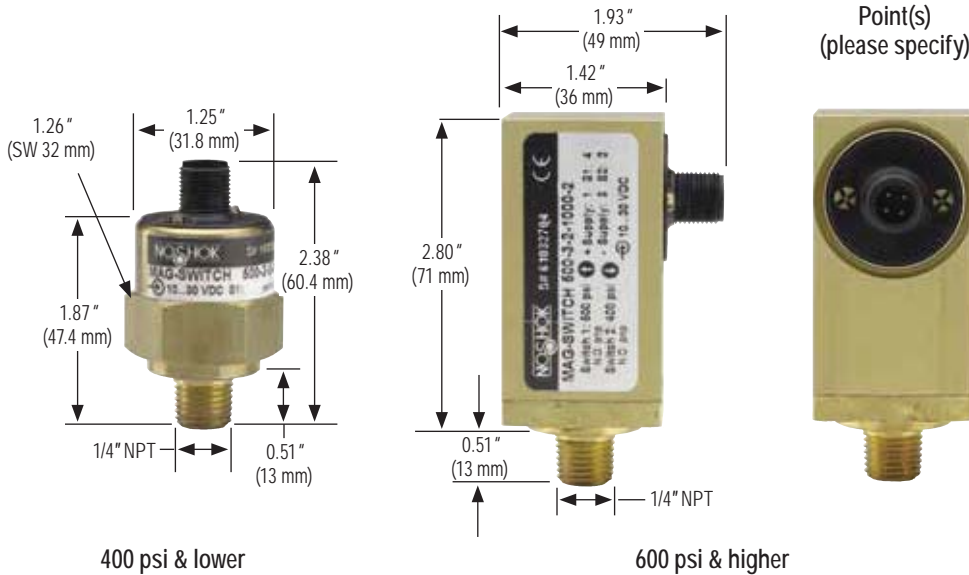

Connection table for M12x1 (4-pin) connector

Function	Connector M12 x 1 (4-pin)
Power supply: +	1 brown
Power supply: -	3 blue
Switching output: S1	4 black
Switching output: S2	5 white

Wiring Diagrams

P-switching, cable or connector
1 switching output

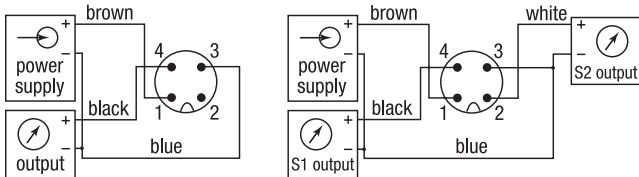

N-switching, cable or connector
1 switching output

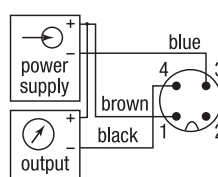

2 switching outputs

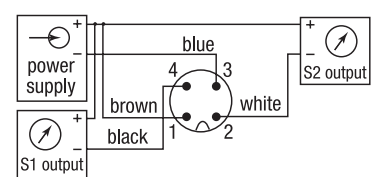



800/810 SERIES

- Compound and standard ranges through 0 psig to 10,000 psig
- Stainless steel wetted parts
- Current and voltage outputs available
- 3 switching output options available:
 - 2 switching outputs
 - 1 switching output & 1 analog output (4 mA to 20 mA or 0 Vdc to 10 Vdc)
 - 2 switching outputs & 1 analog output (4 mA to 20 mA)
- CE compliant to suppress RFI, EMI and ESD

APPLICATIONS

- Hydraulics & pneumatics
- Power generation
- Pumps & compressors
- Stamping & forming presses
- Water & wastewater

Protective Cover Option

- Made of a thermoplastic polyurethane (TPU) material which is resistant to oil, grease and abrasion
- Protects the sensor while maintaining clear viewing and rotation of the display
- The elastic properties of the material allows set point programming without having to remove the cover
- Increases environmental protection to IP67 for indoor and outdoor use



SPECIFICATIONS

Switching parameters	Individually adjustable via external control keys
Number	1 or 2 (PNP or NPN)
Function	N.O./N.C.; windows - and hysteresis function freely adjustable
Contact rating	0.5 A max
Response time	<10 ms
Non-repeatability	<1% full scale
Pressure ranges	-14.5 psig to 30 psig through 0 psig to 9,999 psig
Switch adjustment	Programmable on the display
Switch point	1.0 to 100% of full scale
Hysteresis	0 to 99% of full scale
Transmitter parameters	
Output signal	4 mA to 20 mA or 0 Vdc to 10 Vdc; programmable and freely adjustable
Accuracy	< 0.5% full scale (BFSL) ±1 digit
Hysteresis	< 0.2% full scale (< 0.3 with pressure range < 0 psi - 230 psi)
Adjustment	20% to 100% depending on adjustment range
Durability	> 10,000,000 full scale cycles
Temperature ranges	Compensated 32 °F to 176 °F (0 °C to 80 °C)
	Zero ± 0.07% full scale/ °F
	Span ± 0.07% full scale/ °F
	Media -4 °F to 176 °F (-20 °C to 80 °C) (Thin film sensor)
	-4 °F to 176 °F (-20 °C to 80 °C) (Ceramic sensor)
	Ambient -4 °F to 158 °F (-20 °C to 70 °C)
	Storage -22 °F to 176 °F (-30 °C to 80 °C)
Power requirement*	12 Vdc to 30 Vdc
Current consumption	< 50 mA (without load)
Proof pressure	2 times full scale for ranges vacuum through 0 psig to 1,450 psig 1.75 times full scale for ranges 0 psig to 1,500 psig through 0 psig to 10,000 psig
Burst pressure	2.5 times full scale for ranges vacuum through 0 psig to 1,450 psig. 1.75 times full scale for ranges 0 psig to 1,500 psig through 0 psig 10,000 psig
Measuring element	Stainless steel with ceramic sensor and FKM seal on ranges through 0 psig to 750 psig (other sealing materials available upon request). Stainless steel for higher pressure ranges.
Housing material	800-stainless steel, 810-black anodized aluminum
Connection	316 stainless steel
Environmental rating	IP65
Electromagnetic rating	CE compliant to EMC norm EN 61326:1997/A1:1998 RFI, EMI and ESD protection
Electrical protection	Protected against reverse polarity, over-voltage and short circuit
Shock	> 50 g's according to IEC 60068-2-27
Vibration	> 10 g's according to IEC 60068-2-6
Weight	Approx 0.62 lb

* Unregulated

ORDERING INFORMATION				
SERIES	800 Stainless steel housing			810 Black anodized aluminum housing
SWITCH FUNCTIONS	1 2 N.O. or N.C. (PNP or NPN)			3 1 N.O. or 1 N.C. (PNP or NPN) with 0 Vdc to 10 Vdc analog output
	2 1 N.O. or 1 N.C. (PNP or NPN) with 4 mA to 20 mA analog output			4 2 N.O. or 2 N.C. (NPN) with 4 mA to 20 mA analog output*
PROCESS CONNECTIONS	2 1/4" NPT Male	10 G 1/4 B Male		
	5 1/4" NPT female	11 G 1/2 B Male		
	8 1/2" NPT Male			19 G 1/4 B Female
			45 SAE J1926-3:7/16-20	
ADJUSTABLE RANGES (Max. working pressure)	14.5/30 -14.5 psig to 30 psig	145 0 psig to 145 psig	3750 0 psig to 3,750 psig	
	14.5/75 -14.5 psig to 75 psig	300 0 psig to 300 psig	6000 0 psig to 6,000 psig	
	14.5/145 -14.5 psig to 145 psig	750 0 psig to 750 psig	9000 0 psig to 9,000 psig	
	30 0 psig to 30 psig	1450 0 psig to 1,450 psig	10000 0 psig to 10,000 psig	
	75 0 psig to 75 psig	2400 0 psig to 2,400 psig		
ELECTRICAL CONNECTIONS	2 M12 x 1 (4-pin)		3 M12 x 1 (5-pin), 2 switch and analog output	
OPTIONS	ST8 Threaded Orifice	RB Rotatable Base	EH Enhanced Software**	PC Protective Cover (IP67)

Please consult your local NOSHOK Distributor or NOSHOK, Inc. for availability and delivery information.

* Available only with a M12 x 1 (5-pin) connector. Rotatable base is not available on this option.
 ** Includes minimum/maximum value memory, output dampening, switching time delay

EXAMPLE

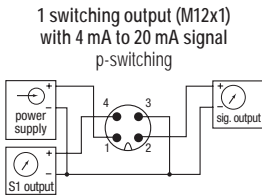

Series 800 Series
 Switch function..... 2 N.O. or N.C. (PNP or NPN)
 Process connection 1/4" NPT Male
 Adjustable range 0 psig to 145 psig
 Electrical connection M12 x 1 (4-pin)
 Option..... Threaded Orifice

800 - 1 - 2 - 145 - 2 - ST8

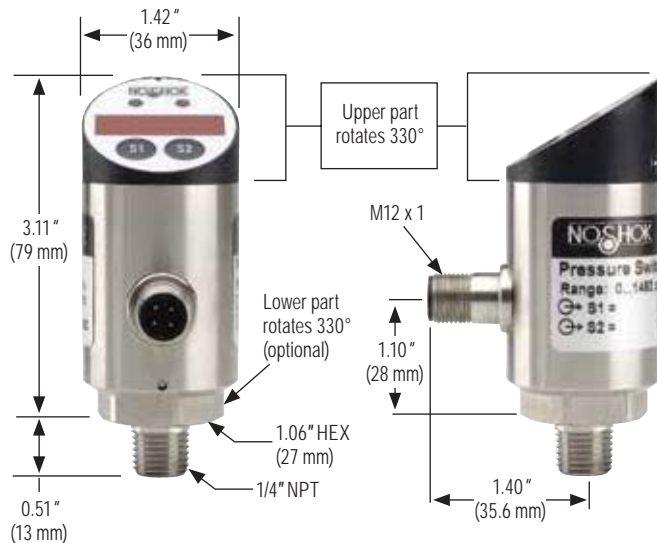
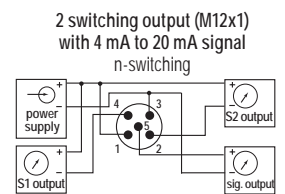
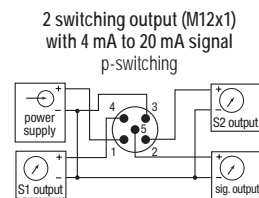
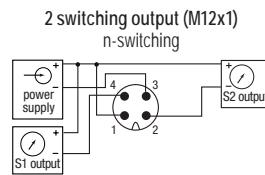
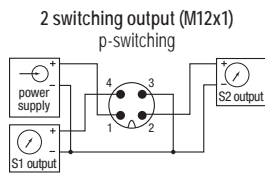
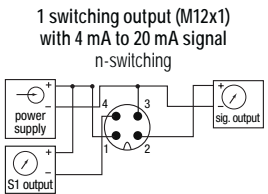

800 Series - Stainless Steel Housing



810 Series - Black Anodized Aluminum Housing

All Pressure Measurement Instrumentation Options & Accessories

PISTON-TYPE SNUBBERS

- Resist clogging and are self cleaning
- Five different sized pistons included with each snubber to ensure the correct amount of snubbing for virtually every application
- Available in brass and 316 stainless steel in 1/4" NPT, 1/2" NPT or SAE J1926-3: 7/16-20
- Weight approximately 0.2 lb. for 1/4" & 7/16", and approximately 0.4 lb. for 1/2"

Options & Accessories

Piston-Type Snubbers Specifications

PART NO.	SIZE	MATERIAL	PRESSURE RATING
1325	1/4" NPT	Brass	6,000 psi
1335	SAE J1926-3:7/16-20	Brass	5,000 psi
1350	1/2" NPT	Brass	6,000 psi
5025	1/4" NPT	316 Stainless steel	15,000 psi
5035	SAE J1926-3:7/16-20	316 Stainless steel	8,000 psi
5050	1/2" NPT	316 Stainless steel	15,000 psi



Piston-Type Snubbers

DIMENSIONS		1/4" NPT	1/2" NPT	SAE J1926-3: 7/16-20
A	IN	0.812	1.125	0.812
	MM	20.6	28.6	20.6
B	IN	1.60	1.875	1.60
	MM	40.6	47.6	40.6
C	IN	1.04	1.25	1.24
	MM	26.4	31.8	31.5
D	IN	0.56	0.625	0.36
	MM	14.2	15.9	9.1

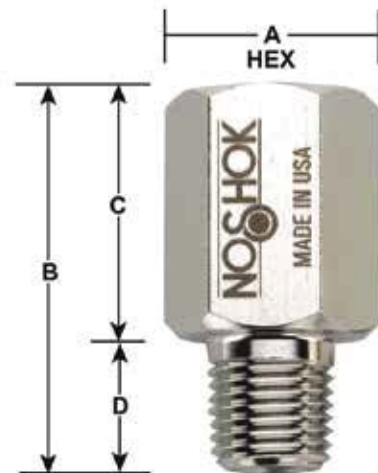

PISTON	SUGGESTED USE
A, B*	Gases
B, C	Water
C, D	Light Oil
E	Heavy Oil

* Snubber assembled and shipped with the B piston installed

SINTERED SNUBBERS

- Cost effective solution to protect expensive instrumentation
- Increases gauge readability by smoothing out pressure surges, pulsations and spikes
- 5 basic elements available for each snubber to accommodate specific application needs
- Snubbing action achieved by utilizing a corrosion resistant 316 stainless steel sintered porous element
- Exotic materials or intermediate disc grades available
- Provides long service life with no moving parts to wear out
- Weight approximately 0.2 lb. for 1/4" & 7/16", and approximately 0.4 lb. for 1/2"



Sintered Snubbers

Options & Accessories Sintered Snubbers Specifications

PART NO.	SIZE	MATERIAL	PRESSURE RATING
1125-X	1/4" NPT	Brass	6,000 psi
1135-X	SAE J1926-3:7/16-20	Brass	5,000 psi
1150-X	1/2" NPT	Brass	6,000 psi
5125-X	1/4" NPT	316 Stainless steel	15,000 psi
5150-X	1/2" NPT	316 Stainless steel	15,000 psi

Note: The "X" in the part number denotes the Disc option (example: 1135-C).
See chart below for Disc options.

DIMENSIONS		1/4" NPT	1/2" NPT	SAE J1926-3 :7/16-20
A	IN	0.812	1.125	0.812
	MM	20.6	28.6	20.6
B	IN	1.60	1.875	1.60
	MM	40.6	47.6	40.6
C	IN	1.04	1.25	1.24
	MM	26.4	31.8	31.5
D	IN	0.56	0.625	0.36
	MM	14.2	15.9	9.1

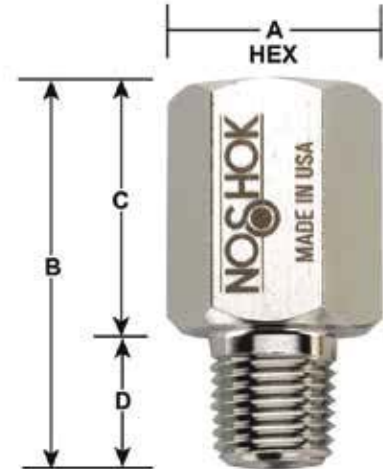

Sintered Snubbers Replacement Disc Options

DISC GRADE	PART NO.	AVERAGE AIR FLOW ESTIMATE	MICRON GRADE (reference)	SUGGESTED USE
A	PD8-A-SS1	0.25 L/MIN @ 1 psi	2	Gases
B	PD8-B-SS1	0.63 L/MIN @ 1 psi	10	Gases, Water
C	PD8-C-SS1	1.46 L/MIN @ 1 psi	20	Water, Light Oil
D	PD8-D-SS1	2.79 L/MIN @ 1 psi	40	Light Oil
E	PD8-E-SS1	3.14 L/MIN @ 1 psi	60	Heavy Oil



Sintered Snubbers Replacement Discs

All Pressure Measurement Instrumentation Options & Accessories

PIGTAIL STEAM SYPHONS

- Protect the instrument from the damaging effects of high temperature steam
- Recommended for use in steam applications and systems that contain superheated vapor
- Available in 1/4" and 1/2" NPT sizes in welded steel, welded 316 stainless steel or seamless 316 stainless steel with ratings to 3,800 psi @ 850 °F



Product Specifications

PART NO.	COIL STYLE	SIZE	MATERIAL
1225	90°	1/4" NPT	Welded steel, schedule 40
1250		1/2" NPT	Welded steel, schedule 80
2225		1/4" NPT	Welded 316SS, schedule 40
2250		1/2" NPT	Seamless 316SS, schedule 80
1025	180°	1/4" NPT	Welded steel, schedule 40
1050		1/2" NPT	Welded steel, schedule 80
2025		1/4" NPT	Welded 316SS, schedule 40
2050		1/2" NPT	Seamless 316SS, schedule 80
1425	270°	1/4" NPT	Welded steel, schedule 40
1450		1/2" NPT	Welded steel, schedule 80
2325		1/4" NPT	Welded 316SS, schedule 40
2350		1/2" NPT	Seamless 316SS, schedule 80
1525	360°	1/4" NPT	Welded steel, schedule 40
1550		1/2" NPT	Welded steel, schedule 80
2525		1/4" NPT	Welded 316SS, schedule 40
2550		1/2" NPT	Seamless 316SS, schedule 80



Pigtail Steam Syphons

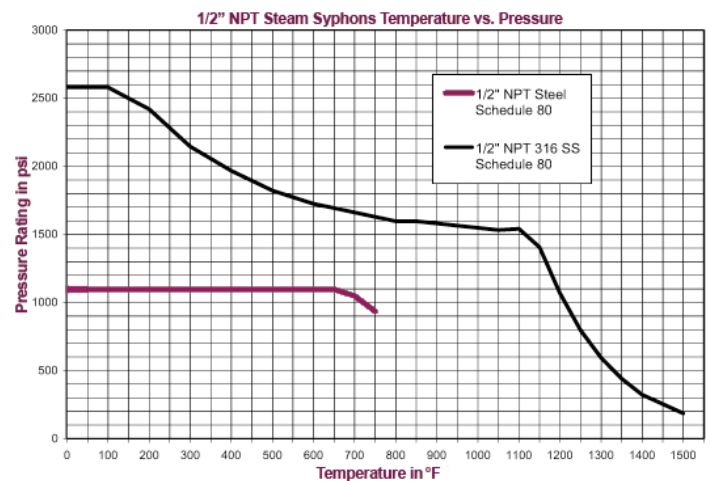
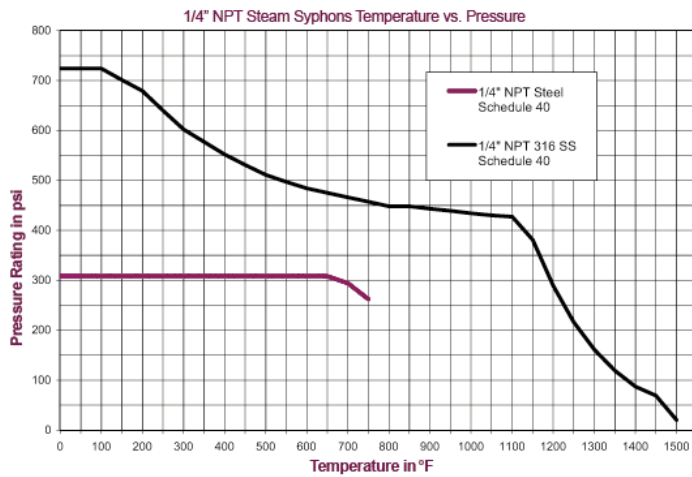

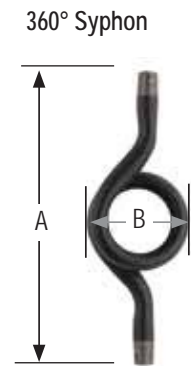
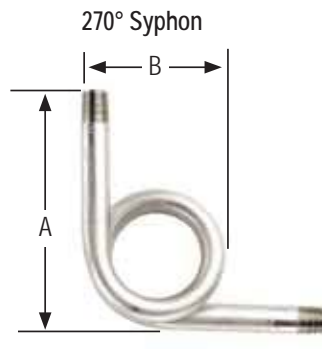
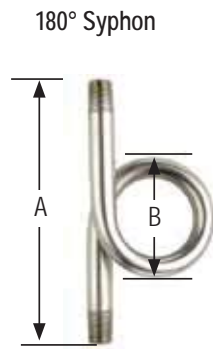
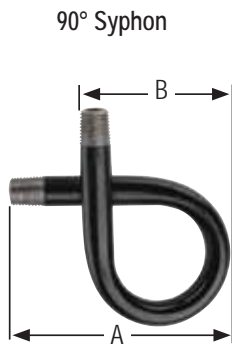

CONNECTION SIZE			1/4" NPT	1/2" NPT
90°	A	IN MM	4.25 107.95	6.5 165.1
	B	IN MM	2.625 66.675	4.0 101.6
180°	A	IN MM	5.5 139.7	8.875 225.425
	B	IN MM	2.5 63.5	4.0 101.6
270°	A	IN MM	4.5 114.3	7.5 190.5
	B	IN MM	2.625 66.675	4.0 101.6
360°	A	IN MM	7.25 184.15	12.0 304.8
	B	IN MM	2.625 66.675	4.125 104.775

SWIVEL ADAPTORS

- Temperature ratings: 15,000 psi @ 200 °F and 3,000 psi @ 1,000 °F
- Used with gauges and gauge valves to adjust the line of sight
- Rotates 360° to allow the connected instrument to be positioned in the desired direction
- The pressure connection is achieved with a tapered cone style compression fitting simply by tightening the swivel hex nut
- All 316 stainless steel construction
- Standard with 1/2" NPT male process – 1/2" NPT female instrument connections
- Also available with 1/4" NPT connections, same specifications apply
- Weight approximately 0.8 lb.

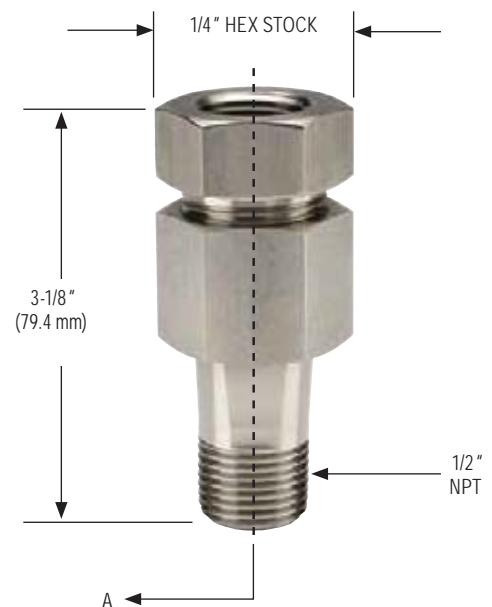

Gauge Configurations for High Temperature Applications

140 °F is the maximum recommended ambient media temperature for NOSHOK pressure gauges with brass wetted parts, and 212 °F for gauges with stainless steel wetted parts. For applications in which media reaches temperatures above 212 °F, NOSHOK offers several accessories designed to prevent damage to the gauge, and maintain maximum performance and accuracy.

Recommended gauge configurations are listed below. Please note that these guidelines are intended to be general recommendations. Many conditions may affect the amount of temperature reduction; including ambient temperature, media type, and process configuration.

- **Up to 140 °F:** All NOSHOK pressure gauges will provide peak performance in this range
- **Up to 212 °F:** A gauge with stainless steel wetted parts is required, such as the NOSHOK 400 and 740 Series. Do NOT use a gauge with brass wetted parts.
- **Up to 287 °F:** Accessories must be used to maintain gauge integrity and accuracy. Options include:
 - o **Pigtail Steam Syphon:** For use with a stainless steel wetted parts gauge. Should be used in steam applications and systems that contain superheated vapor. The pigtail buffers the instrument from the damaging effects of high temperature steam by holding system fluid in the coil to provide a steam trap for the fluid to condensate and dissipate the heat. Reduces temperature by 75° F/ft. on average. Multiple configurations are available.
 - o **Armored Capillary Tube:** For use with a stainless steel wetted parts gauge. Average temperature reduction is 75 °F/ft. Two feet of capillary tube can increase the media temperature range to 362 °F. Standard length is five feet, provided with thread connections; other lengths available on request. Gauge must be separated from the process with a mounting bracket or flange, and the extra capillary length can be rolled up if necessary. Recommended for use with clean media or gases.
 - o **Long Pipe:** 1/2" in diameter or greater in either steel or stainless steel construction with a stainless steel wetted parts gauge. Average temperature reduction is 75 °F/ft. Pipes can be cut and threaded for custom applications.
 - o **Cooling Element:** For use with a stainless steel wetted parts gauge. Average temperature reduction is 75 °F/4" element. Use with other accessories for additional temperature decrease (long pipe, syphon, diaphragm seal).
 - o **Cooling Tower:** For use with a stainless steel wetted parts gauge. Approved usage up to temperatures of 312 °F. Average temperature reduction is 100 °F/8" cooling tower. Recommended for use with clean media or gases.
- **Up to 300 °F:** A high temperature system fill is required, such as silicone D.C 550, and a diaphragm seal is recommended on a stainless steel wetted parts gauge.

For more information, contact NOSHOK at 440.243.0888

The technology used in today's pressure gauges has been around since the mid-eighteen hundreds, and the pressure gauge is still one of the most common methods of measuring pressure today. The majority of pressure gauges today still incorporate the Bourdon tube, socket, and geared movement; along with a pointer and dial to indicate process pressure.

Since the pressure gauge is a purely mechanical device, attention to three process conditions is necessary. The three factors that can adversely affect accuracy and performance are **Temperature, Vibration and Pulsation**.

Temperature Influence:

For every 18 °F (10 °C) shift in temperature from which the gauge is calibrated, the user can experience up to a ±0.4% additional error. The cause is the change in the elasticity or spring rate of the Bourdon tube element with temperature. While it is difficult to circumvent the influence of ambient temperature, we can address the influence of process temperature. In steam service, the common practice is to install coil syphons or pigtail syphons to dissipate process heat. Another common practice is to install a diaphragm seal with capillary to separate the gauge from the high heat source. There are many options available with fill fluid in the seal and capillary system to withstand temperatures up to 600 °F. In severe cold ambient conditions, many users elect to heat trace their instrumentation via electric or steam trace. Process and ambient temperature is an important consideration when selecting and applying pressure gauges.

Vibration Influence:

Vibration due to pumps, motors, and other rotating equipment can cause excess wear and possible premature failure of internal working parts of a pressure gauge, which include the Bourdon tube and the movement or gear mechanism. Vibration also causes difficulty in accurate reading of the gauge, due to pointer oscillation. One of the most common causes of pressure gauge failure is exposure to continuous vibration. The most widely accepted remedy is to utilize a liquid filled pressure gauge. The fill fluid of choice is either Glycerin or Silicone. Liquid filled gauges address not only pointer oscillation, but also serve to protect and lubricate the internal geared movement.

Pulsation Influence:

Process pulsation can occur around the discharge of pumps as well as quick operating valves. Many users assume that liquid filling a pressure gauge will fully address pulsation. Although a liquid filled gauge helps to dampen the effects of pulsation, it often does not fully address this process condition. Pulsation dampeners are installed upstream of the gauge socket and they can be a piston-type snubber, a sintered metal snubber, or a threaded in-flow restrictor in the socket of the gauge. A needle valve installed upstream of the gauge that is "pinched down" or slightly opened, is another common practice to address pulsation. It is not recommended to rely solely on a needle valve to address pulsation, due to the fact that the user could inadvertently open the valve, and thereby negate flow restriction. In clean fluids (gases or clean low viscosity liquids) a threaded orifice/flow restrictor or a sintered metal snubber is the least costly way to address pulsation. In dirtier and higher viscosity fluids a piston snubber is usually installed.

Summary:

Temperature, vibration and pulsation are three process conditions that adversely affect a pressure gauge. Being aware of these three process conditions, and taking the necessary steps to address them, can help minimize accuracy errors and add to the service life of the pressure gauge.

NOSHOK Transducer and Transmitter Pressure Sensing Technologies

Diffused Silicon Semiconductor Strain Gauge Sensor (used in 100, 200, 612, 613, 615, 616, 621, 622, 623, 624, 625, 626, 627, 640 and 650 Series - ranges up to 0 psi to 300 psi)

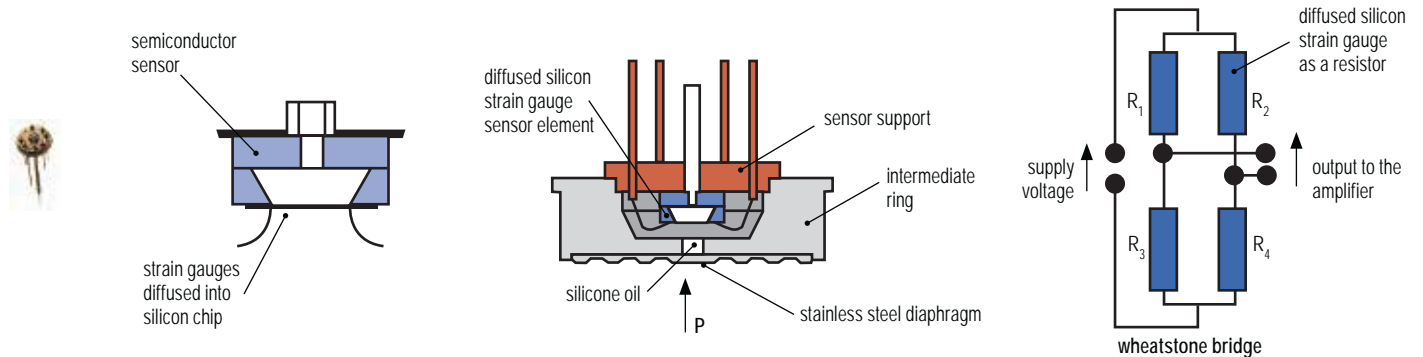

Sputtered Thin Film Strain Gauge Sensor (used in 100, 200, 612, 613, 615, 616, 621, 622, 623, 624, 625, 626, 627, 640, 650, 660, 800/810 Series - ranges 0 psi to 500 psi and higher)

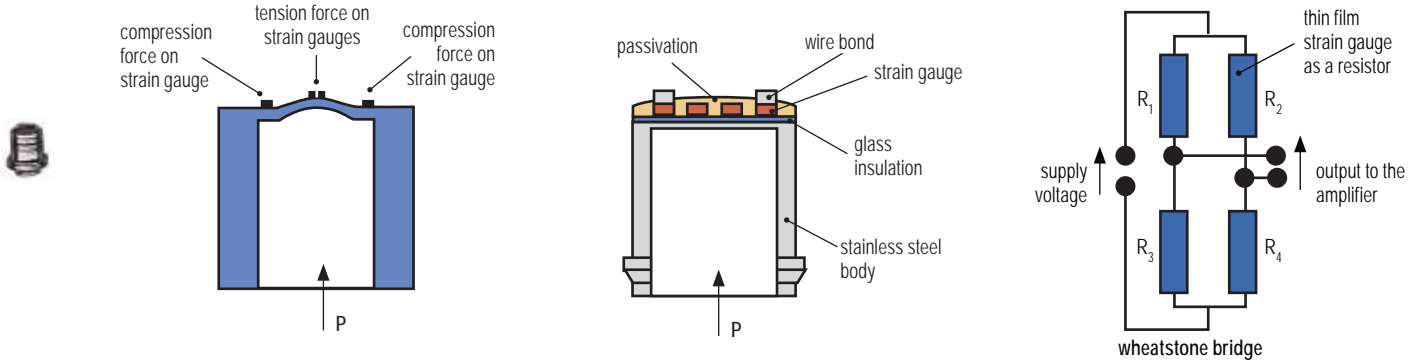

Ceramic Thick Film Strain Gauge Sensor (used in 800/810 and 1000 Series)

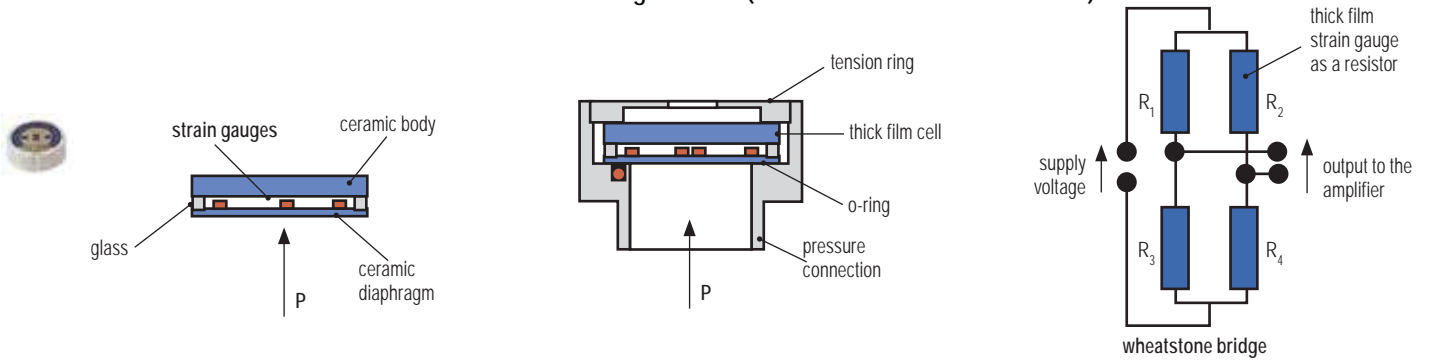

Hall Effect Sensor

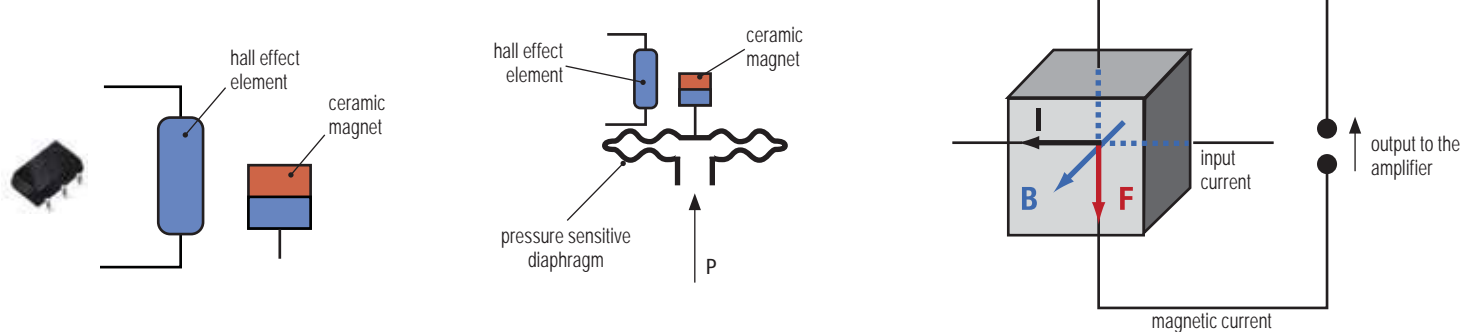

Accuracy according to IEC 61298-2

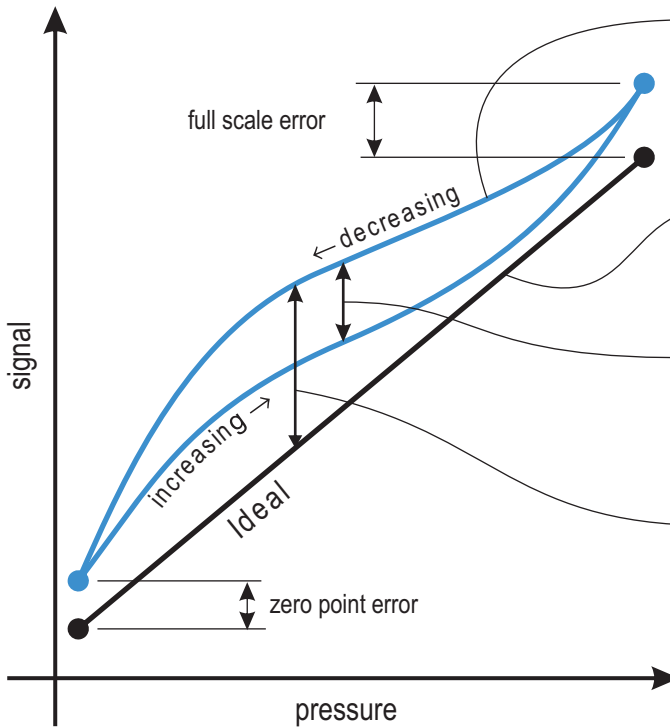

Definitions

Characteristic Curves:

A smooth curve generated through data points recorded from actual input pressures and output signals at increasing and decreasing pressures (upscale and downscale readings)

Ideal Characteristic Line :

A straight line representing an ideal linear relationship between the input pressure and output signal.

Hysteresis:

The maximum difference between the characteristic lines recorded at increasing and decreasing pressure. Expressed in percent of ideal span.

Accuracy :

The maximum deviation from an ideal characteristic line including the effects of non-linearity, hysteresis, non-repeatability, zero point and full scale errors. Expressed in percent of ideal span

Non-Repeatability :

The maximum deviation between values of output for any single input of multiple cycles considering decreasing and increasing pressures separately. Expressed in percent of ideal span.

Non-linearity according to IEC 61298-2

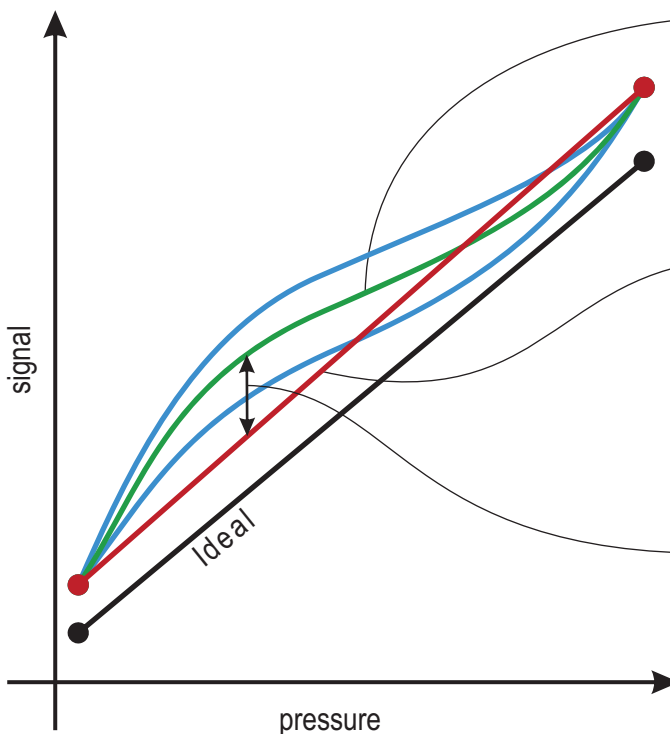

Averaged Characteristic Curve:

A single curve generated through the averaged data of input pressures and output signals at increasing and decreasing pressures. (average of upscale and downscale curves)

Reference line (TP or BSFL):

A straight line coinciding with the actual output data and the averaged characteristic curve. (TP) Terminal Point connects the actual zero point value and the full scale value (BSFL) Best Fit Straight Line connects the data using the least square method to minimize the maximum deviation $TP \cong 2 \times BSFL$

Non-Linearity:

The maximum deviation from the averaged characteristic line to the reference line. Expressed in percent of ideal span.

Thermal Performance of NOSHOK Pressure Transducers

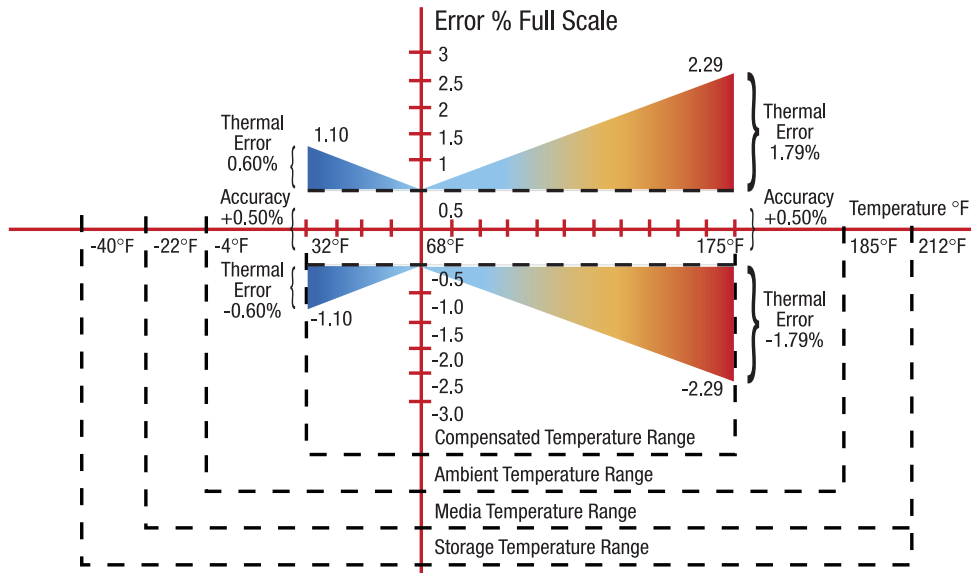

Temperature Performance 100 Series Pressure Transmitter

The above diagram illustrates transducer performance related to the temperature of the environment and media being measured.

The graph shows the worst case performance of the series 100 pressure transmitter as an example (other series follow the same pattern). The thermal specification as indicated in the 100 series specifications is given in a worst case coefficient for the combined effects on zero and span. The definitions are as follows.

The **Compensated Temperature Range** is the thermal band over which the effect specification is guaranteed. For the 100 series, the coefficient is $\pm 0.0167\%$ full scale per $^{\circ}\text{F}$. This means that over the compensated temperature range the thermal boundaries are straight lines as shown. This is sometimes called a “bow-tie effect” or “butterfly effect”.

The **Ambient Temperature Range** is the maximum and minimum ratings over which the transducer will output a correct signal.

The **Media Temperature Range** is the maximum and minimum ratings of the media at the process connection.

The **Storage Temperature Range** is the maximum and minimum ratings for no damage on the shelf.

The Minimum Power Supply Voltage Required For A 2-Wire 4 mA to 20 mA Loop

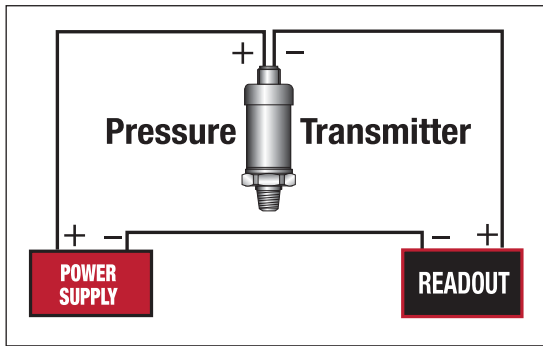

Single instrument 2 wire current loop

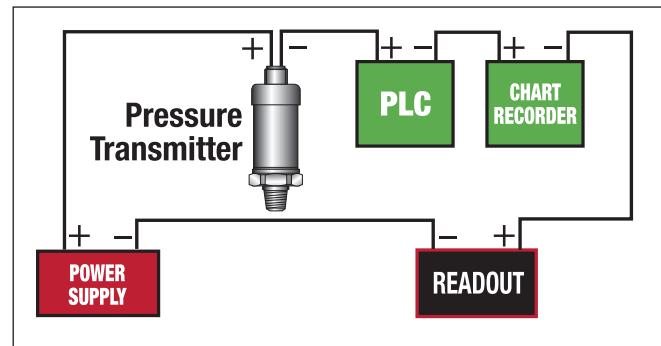

Single instrument 2 wire current loop

For the single instrument 2 wire current loop, the minimum power supply voltage is equal to the required voltage across the transmitter plus the voltage drop across the instrumentation plus the voltage drop caused by the resistance of the wiring.

As an example, for a 100 series (4 mA to 20 mA output) pressure transmitter, $V_{transmitter} = 10 \text{ Vdc}$

$V_{wiring} = \text{Resistance of the wiring (handbook data)} \times 20 \text{ mA maximum current flow in the circuit}$. If the instrumentation has an input resistance of 250Ω and if the resistance of the wiring is minimal (100 ft of 24 AWG leadwire has less than 0.6Ω (negligible) of resistance), then the calculation including the leadwire is as follows:

$$V_{min} = 10 \text{ Vdc} + (250 \Omega) \times .020 \text{ Amp} + (0.6 \Omega) \times .020 \text{ Amp} = 15.012 \text{ Vdc}$$

The power supply must provide at least this voltage with the current consumption of .020 Amp.

In a multiple instrument 2 wire current loop, if the second instrument also has an input resistance of 250Ω , then a second component on the right side of the equation must be included. In this case, the $V_{min} = 20.012 \text{ Vdc}$. A power supply of 24 Vdc, 1 Amp would be a typical choice.

If there is more than 1 transmitter loop operating off of the same power supply then the current (.020 Amp) must be multiplied by the number of loops. It is recommended that the power supply provide 20% to 30% higher excitation voltage than that calculated above.

Load Limitations 4 mA to 20 mA output
$V_{min} = 10V + (.020 \times R_L)$ $R_L = \text{Loop resistance } (\Omega)$ $R_L = R_S + R_W$ $R_S = \text{Sensor resistance } (\Omega)$ $R_W = \text{Wire Resistance } (\Omega)$

Measuring The Pressure Of High Temperature Media

In many applications the medium that the transducer or transmitter will contact may be at an elevated temperature beyond the operational limit of the measuring instrument. Selecting an instrument with a high temperature rating or using diaphragm seals to provide isolation from the medium may not be feasible from a design or economic standpoint.

One way to address this situation is to mount the instrument with a short length of tubing away from the hot area where the measurement needs to be made. With a dead ended pressure chamber, the tubing will effectively dissipate much of the heat and bring the medium in contact with the measuring instrument down to a lower temperature that is within its safe and accurate limit.

The following chart provides the basic information needed to determine the size and material of the tubing needed.

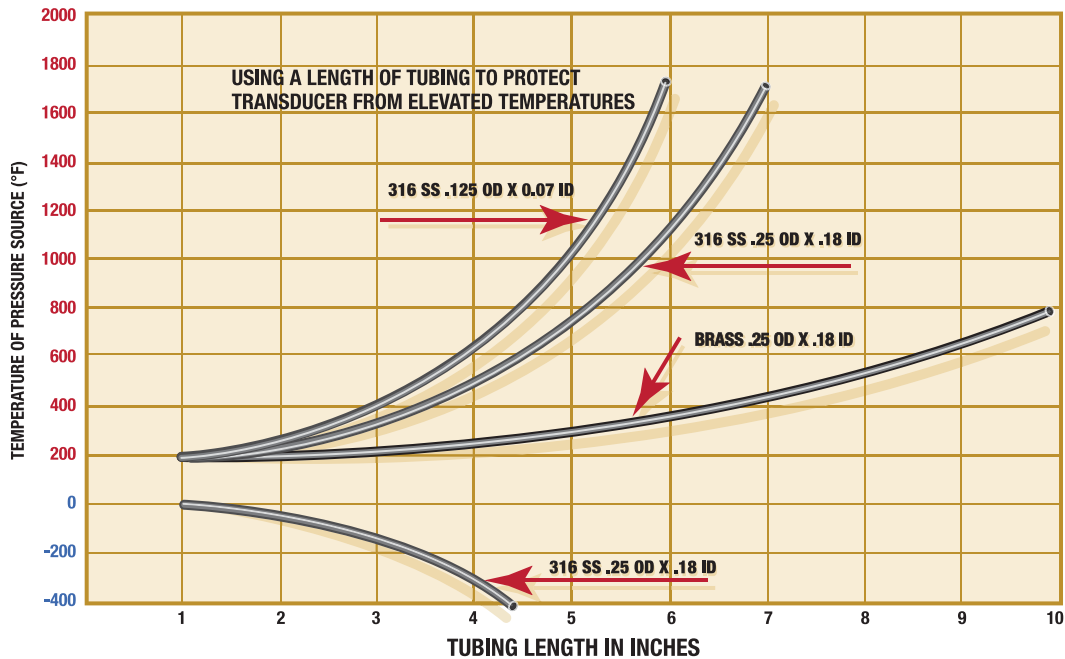

These curves are based upon the following assumptions:

1. The pressure vessel is insulated to limit radiant heat transfer to the transducer – the major source of thermal input is via the connecting tube.
2. The pressure medium has a coefficient of thermal conductivity less than $.4 \text{ btu} / \text{ hr} / \text{ ft}^2 / \text{ ft} / \text{ }^\circ\text{F}$. This figure encompasses a wide range of liquids and gases.
3. The ambient temperature T_A around the transducer is $100 \text{ }^\circ\text{F}$.
4. The heat transfer rate (convection) from the tubing to still air is $1.44 \text{ btu} / \text{ ft}^2 / \text{ hr} / \text{ }^\circ\text{F}$.

Environmental Ratings

IP Environmental Protection Codes

First Numeral - Protection from Particles

- 0 No protection
- 1 Particles >50 mm
- 2 Particles >12 mm
- 3 Particles >2.5 mm
- 4 Particles >1 mm
- 5 Dust protected - limited ingress, no deposits
ingress permitted
- 6 Dust tight - totally protected

Second Numeral - Protection from Water

- 0 No protection
- 1 Vertical falling water
- 2 Direct sprays up to 15° from vertical
- 3 Direct sprays up to 60° from vertical
- 4 Direct sprays from all directions - limited ingress permitted
- 5 Low pressure jets of water from all directions - limited
- 6 Strong jets of water from all directions
- 7 Immersion in water from 15 cm to 1 m
- 8 Immersion in water under pressure for long periods of time
- 9 High pressure steam jet up to 100 bar

IP (first numeral, second numeral), for example IP67

Environmental ratings on NOSHOK transducers are indicated with the individual specifications throughout this catalog. The following ratings are used and this is how they are defined.

- IP65** Totally protected from dust as well as protection from low pressure jets of water from all directions - limited ingress permitted (no effect on performance)
- IP67** Dust tight and capable of immersion in water from 15 cm to 1 m
- IP68** Capable of immersion in water for long periods of time.
- IP69K** Capable of steam jet washdown.

Since IP65, NEMA 4 and NEMA 4X are related, the differences are in the standards used in qualification. Here they are:

	IP65	NEMA 4
Method	Stream of water	Stream of water
Nozzle Size	1/2 "	1 "
Distance	10 ft	10 ft
Duration	15 minutes	5 minutes
Direction	All angles	All angles
Pressure/Flow	10 m of water	65 gallons/min.

In order to meet the standard, the IP65 test results allow some ingress of water as long as it does not affect the performance of the instrument. In order to meet the standard, the NEMA 4 test results do not allow any ingress of water. NEMA 4X includes the NEMA 4 standard requirements plus corrosion resistance.

Hazardous Location Classifications (NEC)

Class I: *Areas in which flammable gases or vapors may be present in the air in sufficient quantities to be explosive*

Group A: Atmospheres containing acetylene

Group B: Atmospheres such as butadiene, ethylene oxide, propylene oxide, acrolein, or hydrogen (gases or vapors equivalent in hazard to hydrogen, such as manufactured gas)

Group C: Atmospheres such as cyclopropane, ethyl ether, ethylene, gas or vapors of equivalent hazard

Group D: Atmospheres such as acetone, alcohol, ammonia, benzene, benzol, butane, gasoline, hexane, lacquer solvent vapors, naphtha, natural gas, propane, or gas or vapors of equivalent hazard

Class II: *Areas made hazardous by the presence of combustible dust*

Group E: Atmospheres containing combustible metal dusts, regardless of resistivity; dust of similarly hazardous characteristics having a resistivity of less than 100 K Ω -cm; electrically conductive dusts

Group F: Atmospheres containing combustible carbon black, charcoal, or coke dusts having more than 8% total volatile material; dusts so sensitized that they present an explosion hazard, and dusts having a resistivity of greater than 100 Ω -cm but less than or equal to 1x10⁸ Ω -cm

Group G: Atmospheres containing combustible dust having resistivity equal to or greater than 100K Ω -cm; electrically nonconductive dusts

Class III: *Areas made hazardous by the presence of easily ignitable fibers or dust, but which are not likely to be in suspension in the air in quantities that are sufficient to ignite*

Division 1: Atmospheres where hazardous concentrations exist continuously, intermittently or periodically under normal operating conditions

Division 2: Atmospheres where hazardous concentrations exist only in case of accidental rupture or breakdown of equipment

Hazardous Location Pressure Measurement with NOSHOK Pressure Transmitters

NOSHOK has solutions to your applications in areas with flammable gases and liquids. Let's start with the definitions related to equipment used in hazardous environments:

Intrinsic Safety Protection

Protection in which the measurement system contains only transmitters and associated equipment that are incapable of causing ignition of the surrounding flammable atmosphere. Normally an intrinsic safety barrier is employed between the transmitter which is located in the hazardous area and the downstream receiving equipment. This barrier contains an electrical network designed to limit the energy (voltage and current) available to the protected circuit in the hazardous location under specified fault conditions. NOSHOK 625, 626 and 627 Series are Factory Mutual and Canadian Standards Association approved as intrinsically safe.

Non-Incendive Protection

Protection in which the measurement may contain arcing or sparking equipment but is still incapable, under specified test conditions, of igniting the flammable gas, vapor or dust-air mixture. This applies only in Division 2 environments. An intrinsic safety barrier is not required in this measurement system. No special wiring is required. NOSHOK 623 and 624 Series are Factory Mutual and Canadian Standards Association approved as non-incendive.

Explosion-Proof Protection

Protection in which the enclosure of the transmitter is capable of withstanding an explosion of the specified gas or vapor that may occur within it and of preventing the ignition of a specified gas or vapor surrounding the enclosure by sparks, flashes or explosion of the gas or vapor within, and that operates at such an external temperature that a surrounding flammable atmosphere will not be ignited. Explosion-proof installation techniques are required including special electrical conduit and junction boxes. NOSHOK 621 and 622 Series are Factory Mutual approved as explosion-proof.

Why NOSHOK Is The Best Choice

- Stable sensing technologies mean that there is no need for periodic recalibration. NOSHOK transducers do not have glues, epoxies or adhesives in the transduction portion of the sensor module because such organic agents cause calibration drift with temperature and pressure cycling, and over time in some applications, cause complete failure.
- Broad product offering results in best fit of product configuration to customer application requirements.
- CE compliance and an environmentally hardened design mean maximum performance and reliability in difficult real world applications. Products are manufactured in an ISO 9001 certified facility.
- All product specifications are conservatively stated in the literature so that product performance exceeds customer expectations.
- No specsmanship or games are ever employed, only honest information.
- The calibration of every product is verified in NOSHOK's modern facility with the best available pressure controllers and computerized readout equipment that are at least 4 times the accuracy of the product being checked.
- Highly automated production minimizing the variations in product caused by human labor mean more consistency from unit to unit resulting in interchangeability and consistent performance.
- Simple and proven dc electronics improves reliability and longer mean time between failure (MTBF) characteristics.
- While field failures are few, NOSHOK backs its electronic products with a 3-year warranty that is the best in the market.
- Products provide significant performance and application flexibility at competitive prices addressing the needs of the OEM and the user alike.
- As a privately owned and run business, NOSHOK employees focus on continually improving customer satisfaction.

Specsmanship - What to Look for in Comparing Other Transducers and Transmitters to NOSHOK Products

- Be on the lookout for suppliers specifying "high accuracy" with a low price. In many cases you will find indications of zero offsets and span offsets of up to 2% each. The specified accuracy of NOSHOK transducers includes any offsets and is a true accuracy upon which you can depend.
- If the competitors do not specify a long term stability specification, then this bears out our contention that many of these other sensing technologies do not yield an attractive stability specification otherwise it would be printed in the literature.
- Look out for the "typical" nomenclature or the Root-Sum-Square (RSS) designation. While these methods provide a statistical probability of how most of the products will perform, it means that if a quantity of units is considered then a percentage of the products will not meet the listed specification. NOSHOK specifications are worst case, so all the transducers meet that specification.

NOSHOK Transmitters/Transducers Wiring Diagrams & Electrical Connections for 100, 200, 300, 612, 615/616, 640, 660 and 800 Series

Installation: NOSHOK pressure transmitters/transducers may be mounted in any plane with negligible effect on performance. Although these units are designed and manufactured to withstand substantial shock and vibration, it is recommended that they be mounted in an area of minimal vibration. Always use a wrench on the wrench flats when installing. NEVER use a pipe wrench on the housing or in the area of the electrical connection.

Maintenance/Calibration: NOSHOK pressure transmitters/transducers require no maintenance. Recalibration is dependent on the users Quality Assurance Program. If no program is in place, NOSHOK recommends a 1 year cycle.

Alignment Procedure

Using a pressure source and meter with adequate accuracy, perform the following steps:

- Open sensor
- With no pressure applied, adjust the "Z" potentiometer for the correct Zero output
- Apply the correct full scale pressure to the unit
- Adjust the "S" potentiometer for the correct Span output

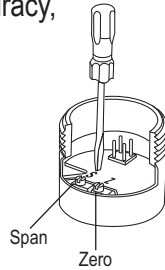

SERIES 100

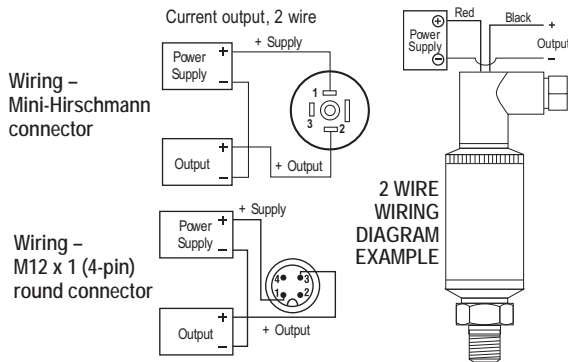

Load Limitations
4 mA to 20 mA Output Only
 $V_{min} = 10V + (.020 \times R_L)$
 $R_L = R_S + R_W$
 R_L = Loop Resistance (Ω s)
 R_S = Sense Resistance (Ω s)
 R_W = Wire Resistance (Ω s)

Series 100	4 mA to 20 mA 2-wire
+ Supply	Red/1/A/1/Brown
+Output	Black/2/B/3/Blue

Example: Red/1/A/1 = Applicable color wire/din plug number/Bendix pin/M12 x 1 pin number/M12 integral cable color wire

SERIES 200

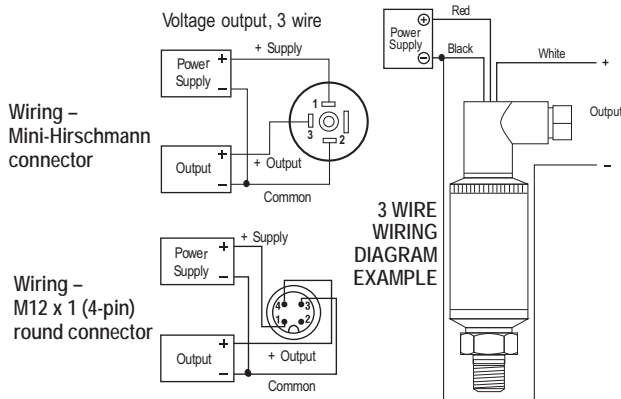

Series 200	0-5, 1-6, -10 1 Vdc to 11 Vdc 3-WIRE
+ Supply	Red/1/A/1/Brown
Common	Black/2/B/3/Blue
+Output	White/3/C/4/Black

Example: Red/1/A/1 = Applicable color wire/din plug number/Bendix pin/M12 x 1 pin number/M12 integral cable color wire

SERIES 612 & 613

2 WIRE WIRING DIAGRAM EXAMPLE

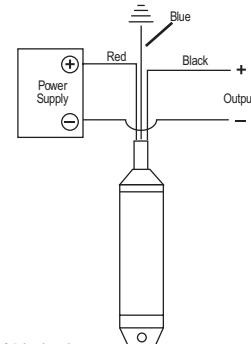

Load Limitations

4 mA to 20 mA Output Only
 $V_{min} = [10V + (.020 \times R_L)] - 0.04352 \frac{\Omega}{Ft.} \times$
cable length

$R_L = R_S + R_W$
 R_L = Loop Resistance (Ω s)
 R_S = Sense Resistance (Ω s)
 R_W = Wire Resistance (Ω s)

Series 612	4 mA to 20 mA 2-wire
+ Supply	Red
+Output	Black
Case ground	Blue

3 WIRE WIRING DIAGRAM EXAMPLE

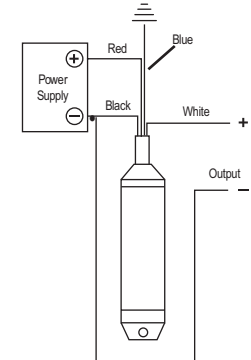

Load Limitations

4 mA to 20 mA Output Only
 $V_{min} = [10V + (.020 \times R_L)] - 0.04354 \frac{\Omega}{Ft.} \times$
cable length

$R_L = R_S + R_W$
 R_L = Loop Resistance (Ω s)
 R_S = Sense Resistance (Ω s)
 R_W = Wire Resistance (Ω s)

Series 612	Voltage Output
+ Supply	Red
Common	Black
+Output	White
Case ground	Blue

SERIES 615/616

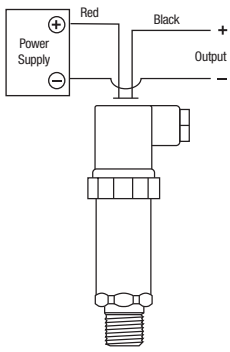

2 WIRE WIRING
DIAGRAM EXAMPLE

Load Limitations 4 mA to 20 mA Output Only
 $V_{min} = 10V + (.020 \times R_L)$
 $R_L = R_S + R_W$
 R_L = Loop Resistance (Ω)
 R_S = Sense Resistance (Ω)
 R_W = Wire Resistance (Ω)

Series 615/616	4 mA to 20 mA 2-wire
+ Supply	Red/1/A/1/1/Brown
+Output	Black/2/B/2/3/Blue

Series 615/616	Voltage Output
+ Supply	Red/1/A/1/1/Brown
Common	Black/2/B/2/3/Blue
+Output	White/3/C/3/4/Black

Example: Red/1/A/1/1 = Applicable color wire/
din plug number/Bendix pin/junction
box pin/M12 x 1 pin number/M12 integral
cable color wire

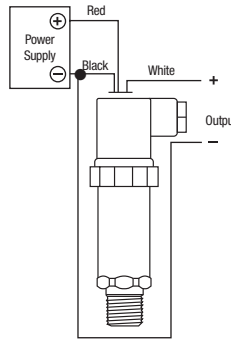

3 WIRE WIRING
DIAGRAM EXAMPLE

SERIES 640

Wiring - M12 x 1 (4-pin)
round connector

Current output, 2 wire

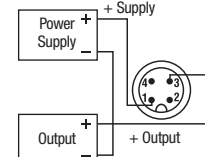

Voltage output, 3 wire

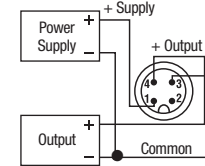

Load Limitations

4 mA to 20 mA Output Only

$$V_{min} = 10V + (.020 \times R_L)$$

$$R_L = R_S + R_W$$

R_L = Loop Resistance (Ω)

R_S = Sense Resistance (Ω)

R_W = Wire Resistance (Ω)

SERIES 300

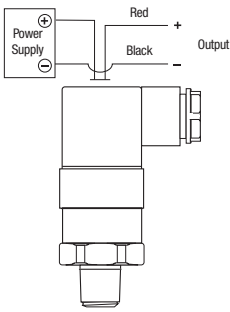

2 WIRE WIRING
DIAGRAM EXAMPLE

Load Limitations 4 mA to 20 mA Output Only
 $V_{min} = 10V + (.020 \times R_L)$
 $R_L = R_S + R_W$
 R_L = Loop Resistance (Ω)
 R_S = Sense Resistance (Ω)
 R_W = Wire Resistance (Ω)

Series 300	4 mA to 20 mA 2-wire
+ Supply	Red/1/1/1/Brown
+Output	Black/2/2/3/Blue

Series 300	Voltage Output
+ Supply	Red/1/A/1/1/Brown
Common	Black/2/2/3/Blue
+Output	White/3/3/4/Black

Example: Red/1/1/1 = Applicable color wire/
din plug number/junction box pin/
M12 x 1 pin number/M12 integral
cable color wire

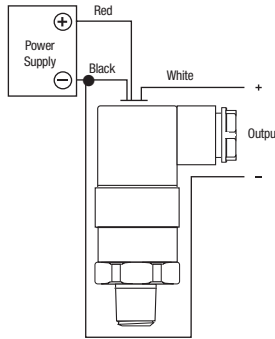

3 WIRE WIRING
DIAGRAM EXAMPLE

RS 232 Interface

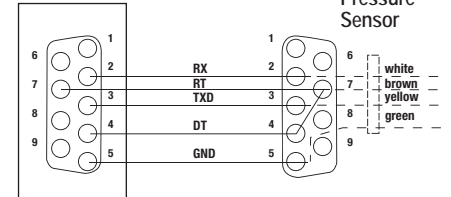

Pressure
Sensor

SERIES 800

4 mA to 20 mA, 2 wire

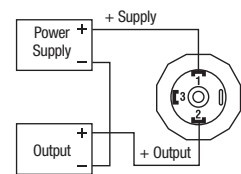

0 Vdc to 10 Vdc, 3 wire

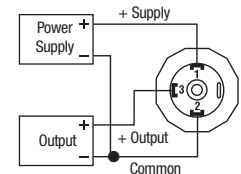

Load Limitations

4 mA to 20 mA Output Only

$$V_{min} = 10V + (.020 \times R_L)$$

$$R_L = R_S + R_W$$

R_L = Loop Resistance (Ω)

R_S = Sense Resistance (Ω)

R_W = Wire Resistance (Ω)

Series 800	4 mA to 20 mA 2-wire
+ Supply	Red/1
+Output	Black/2

Series 800	Voltage Output
+ Supply	Red/1
Common	Black/2
+Output	White/3

Example: Red/1 = Applicable color wire/
din plug number.

SERIES 660

Wiring - Mini-Hirschmann
connector

Current output, 2 wire

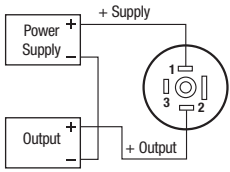

Voltage output, 3 wire

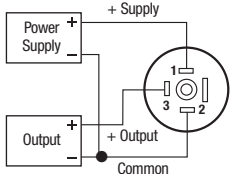

Load Limitations 4 mA to 20 mA Output Only
 $V_{min} = 10V + (.020 \times R_L)$
 $R_L = R_S + R_W$
 R_L = Loop Resistance (Ω)
 R_S = Sense Resistance (Ω)
 R_W = Wire Resistance (Ω)

Series 660	4 mA to 20 mA 2-wire
+ Supply	Brown/1/1/Brown
+Output	Green/2/3/Blue

Series 660	Voltage Output
+ Supply	Brown/1/1/Brown
Common	Green/2/3/Blue
+Output	White/3/4/Black

Example: Brown/1/1 = Applicable color wire/
din plug number M12 x 1 pin number/M12
integral cable color wire

Wiring - M12 x 1 (4-pin)
round connector

Current output, 2 wire

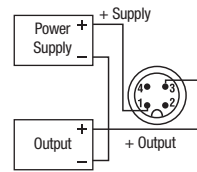

Voltage output, 3 wire

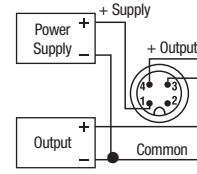

Q: What is the purpose of the ventable & non-ventable fill plug/relief plug?

A: A fill plug seals the fill hole in a pressure gauge case. On liquid filled pressure gauges, a ventable fill plug is used to relieve internal case pressures that occur due to thermal expansion of the fill fluid. In non-filled dry gauges, a non-ventable fill plug is used to occasionally drain the interior of the case from condensate or relieve internal case pressures. Ventable fill plugs incorporate a vent pin to open and close a hole for relieving internal case pressures and do not have to be removed from the case hole like non-ventable fill plugs.

Q: What are the designed overpressure ratings for NOSHOK gauges?

A: Overpressure ratings are specific to the gauge type, pressure range and accuracy ratings of the gauge. Normal overpressure protection can range from 1.1X to 1.3X depending on the gauge selected. NOSHOK gauges comply to the EN-837-1 and ASME B40.1 standards in regards to overpressure protection. When selecting a pressure gauge, it is recommended that the normal system pressure be maintained around half of the full range of the gauge as to avoid overpressure conditions. Overpressure protection of 3 times up to 10 times of the dial range is available on some series as a production option.

Q: How is the accuracy of a gauge affected by a Maximum Indicating Pointer?

A: A Maximum Indicating Pointer (MIP), also commonly referred to as a Tell Tale Pointer, adds an additional $\pm 1\%$ error to the pressure gauge due to the increase load on the Bourdon tube.

Q: What is a Certified Calibration?

A: Certified Calibrations provide the user with a serial numbered gauge along with a calibration certificate that it has been certified in accordance to the pressure gauge standard with instruments that are traceable to NIST with accuracies of at least 4 to 1.

Q: What is a Certificate of Conformance?

A: A Certificate of Conformance is a formal statement on company letterhead stating that an instrument complies with a particular standard. It contains the signatures of the required personnel. These Certificates are often needed to show industry inspectors that a system and its components are in compliance.

Q: How often does a gauge need to be calibrated?

A: NOSHOK pressure gauges require little or no calibration within the Warranty period. Some applications may be more aggressive than others, resulting in an increased frequency in the need for calibration. The environmental limitations for the pressure gauge series should be observed in all cases. Gauges used in situations outside these requirements may result in inaccuracies, premature wear and/or failure of the gauge and would require additional maintenance. The frequency of calibration, therefore, is up to the user to judge.

Q: When is it recommended to use an orifice?

A: Orifices are a type of snubber. On pressure systems that have rapidly increasing or decreasing pressure spikes, orifices lessen the effects of these energy pulses by blocking the wave energy using restricted flow. They are recommended in dynamic pressure applications with mild pressure spikes.

Q: When is a diaphragm seal used, and when would you apply a diaphragm seal and capillary?

A: A diaphragm is used to isolate and protect the instrument from the process media. Damaging process media may include corrosives, particulates, temperatures, or any state that is not suitable for direct contact with the measuring element. Diaphragms indirectly transmit system pressures by segregating the process pressure with a thin flexible membrane that in turn transfers the pressure through a fill fluid to the instrument. Diaphragms are often used in conjunction with capillaries to further distance the instrument from the process media. Capillary tubes transmit the diaphragm fill fluid to the instrument. Capillary tubes come in several lengths and provide the user a means to measure in a remote location and may also act as heat dissipaters in high temperature applications.

Q: What is the purpose of liquid filling a gauge, and in what applications would a liquid filled gauge be used?

A: Primarily, in applications that have vibrations or pulsations, liquid filling enables reading the dial pointer by dampening the movement. Liquid filling should be considered in any system that has high dynamic operating conditions. In general, liquid filling helps extend the life of a gauge. It reduces damaging resonance induced fracturing, reduces frictional wear, prevents aggressive ambient air from entering, prevents condensation formation, and improves reliability.

Q: How does temperature affect the accuracy of a pressure gauge?

A: Temperature changes affect the stiffness of a Bourdon tube. The stiffness change is produced by a combination of changes in the elastic (Young's) modulus and a change in linear dimensions due to linear expansion and contraction. The error caused by temperature change will follow the approximate formula: $\pm 0.04 \times (t_2 - t_1)$ % of the span.

Q: How do you select a pressure gauge relative to process pressures, normal operating pressures, and maximum pressures in the process? (Dynamic or static process pressures)

A: The pressure range of a gauge should be 10% over the maximum working pressure in static conditions (no pressure fluctuations). In dynamic conditions, the gauge range should be 40% over the maximum working pressure. Ideally, the pressure gauge range should be selected for a midscale reading during normal operating pressures.

Q: What applications require the various lens materials, and to what maximum temperature can each be subjected?

A: Lens materials include Instrument Glass, Laminated Safety Glass, Tempered Glass, and plastic. Glass lenses are used for abrasion, chemical and wear resistant properties. Laminated Safety Glass reduces the possibility of shattering if the Bourdon tube ruptures. Tempered Glass is 2 to 5 times stronger than Instrument Glass. Plastic lenses are used for impact, corrosion and chemical resistance. Special attention should be paid to the temperature and corrosive environments. Polycarbonate is selected for its superior impact resistance, acrylic for its clarity and scratch resistance and Homalite for its superior chemical resistance. In general, gauges with plastic lenses should remain below 140° F.

Q: In what situation would a pigtail syphon be used?

A: Pigtail syphons should be used in steam applications and systems that contain superheated vapor. The pigtail buffers the instrument from the damaging effects high temperature steam by holding system fluid in the coil to provide a steam trap for the fluid to condensate and dissipate the heat.

Q: What is the application for a gauge cleaned for O2 service?

A: Oxygen (O₂) cleaning is performed on gauges that are used on oxygen service applications. The cleaning removes all hydrocarbons (oil and grease are common hydrocarbons) that can react violently, resulting in explosions, fire, and injury to personnel and property. Oxygen clean gauges can be used in any application that requires the cleanliness level associated with oxygen clean gauge. Glycerin fill gauge cannot be used on oxygen systems.

Q: What fill fluids options are available, and in what applications would each be used?

A: Glycerin is the most common fill fluid. Because of its unique fluid properties, Glycerin has become the standard for liquid filled gauges (see "What is the purpose of liquid filling a gauge?"). Glycerin's clarity, viscosity, stability, cost, solubility, low toxicity make Glycerin an ideal fluid for many applications. Mineral oils and silicon fluids are used when temperature extremes, chemical compatibility or viscosity fall outside of Glycerin use. Halocarbon® is an inert fluid that is compatible with chlorine, oxygen service, and some high temperature applications. Keep in mind that Glycerin is not compatible with strong oxidizers such as oxygen, chlorine, hydrogen peroxide, or nitric acid. Glycerin & Silicon are explosive in contact with chlorine. Halocarbon® is explosive in contact with aluminum and magnesium.

Q: What is the difference between ANSI vs. DIN specification?

A: ANSI is the official U.S. representative to the International Organization for Standardization (ISO) and, via the U.S. National Committee, the International Electrotechnical Commission (IEC). ANSI is also a member of the International Accreditation Forum (IAF) for the American National Standards Institute. It approves American National Standards which include ASME B40.1. DIN stands for Deutsches Institut für Normung e.V. (DIN; in English is the German Institute for Standardization) is the German national organization for standardization and is that country's (ISO) member body. Many of the DIN standards have been converted to ISO standards.

Q: What is the purpose of throttle devices such as throttle plugs and screws?

A: Throttle devices limit the flow to the pressure instrument. They are a type of snubber.

Q: What is the purpose of an over and under load stop in a pressure gauge?

A: The tip motion of a Bourdon tube is translated to rotary motion of a pointer by a linkage and sector gear acting on the pointer pinion gear. Stop pins limit the movement of the Bourdon tube, sector or pointer rotation in over and under pressure conditions that would otherwise move the pointer pinion off the sector gear which would damage the gauge.

Frequently Asked Questions - Electronics

Q. What is the difference between a transducer and transmitter?

A. When these terms originated there was a distinctive difference between the two. A transmitter was referred to as an instrument with a current output signal (i.e. 4 mA to 20 mA) and a transducer was referred to as an instrument with a voltage signal (i.e. 3 mV/V, 0 Vdc to 10 Vdc etc.). As time has progressed these terms are now commonly interchanged for reference to current, voltage and digital output signals.

Q. What is the difference between the proof pressure and burst pressure specifications?

A. Proof pressure which is higher than the full scale pressure point is the limit that you can go to without affecting the performance and calibration of the transducer. The burst pressure on the other hand is the limit that you can go before there is pressure chamber rupture and damage. An overload limit specification used sometimes means that proof and burst ratings are identical.

Q. Will the series 1800 Attachable Loop Indicator work with transmitters not made by NOSHOK?

A. The series 1800 indicator will work with any brand that has the same pin connections and style Hirschmann connector and sufficient power supply voltage to drive all instruments in the loop. The series 1800 will use 3 Vdc to operate.

Q. What does RFI, EMI and ESD mean related to pressure transducers and transmitter?

A. Radio Frequency Interference and Electromagnetic Interference refer to the effects electrical noise can have on instruments. RFI frequently comes from hand held walkie-talkies and EMI comes from AC motors in the vicinity of the instrument. ESD (Electrostatic Discharge) comes from many sources including the application itself. CE compliant transmitters and transducers incorporate protection techniques and components to minimize most of the interference.

Q. Can traditional diaphragm seals or gauge protectors be used with pressure transducers and transmitters?

A. Most diaphragm seals can be used with pressure transducers and transmitters. The real key is to assemble and fill the seal properly, being careful not to entrap air in the fill fluid.

Q. Are pigtail steam syphons used in transmitter applications?

A. The steam syphon is necessary in steam pressure applications. It is important to isolate the transmitter sensing diaphragm from the high temperature encountered with steam pressure applications.

Q. Can orifices and snubbers be used and why would they be needed?

A. As with other pressure measurement instruments including gauges, pressure pulsations and spikes, are issues with pressure transmitters. Whenever the pressure of an incompressible fluid is measured, there is the potential for pulsations and spikes, which can damage pressure transmitters. An orifice installed in the pressure connection by NOSHOK can protect the transmitter from damage. Where there is the possibility of clogging the small orifice, an attachable piston snubber is recommended.

Q. What is the reason for the vent tube in the cable of the 612 and 627 Series submersible level transmitters?

A. All pressure measurements are inherently differential in theory. Gauge pressure is referenced to ambient atmospheric, absolute pressure is referenced to vacuum contained in an evacuated chamber within the transmitter. The level measurement is also a differential measurement, with its reference to ambient atmospheric pressure. In order for the submersible level measurement to be referenced to atmospheric, the cable contains a vent tube which runs the complete length of the cable and "vents" into the atmospheric pressure at the junction box connection which is out of the liquid.

Q. How does the series 612 and 627 submersible level transmitter measure level?

A. The transmitter measures the hydrostatic pressure produced by the liquid level higher than the point where the instrument is located. The higher the liquid, the higher the pressure.

Q. NOSHOK transducers and transmitters are normally 2 wire or 3 wire in output configuration. Is a 4 wire transducer available?

A. Voltage output transducers are available with a 4th connection which is electrically the same as the power supply common to connect to wiring configurations that require it.

Canadian Registration Numbers

CRN documents are available at www.noshok.com.

Category:	F. Measuring Devices
Type of Fitting:	Including pressure gauges, level gauges, sight glasses, level or pressure transmitters
Alberta	0F15217.52
British Columbia	0F15217.51
Manitoba	0F15217.54
New Brunswick	0F15217.57
Newfoundland & Labrador	0F15217.50
Northwest Territories	0F15217.5T
Nova Scotia	0F15217.58
Nunavut	0F15217.5N
Ontario	0F15217.5
Prince Edward Island	0F15217.59
Quebec	CSA-0F15217.56
Saskatchewan	CSA-0F15217.56
Yukon Territory	0F15217.5Y

NOTES



A decorative background featuring a large, light gray, stylized 'NO' graphic. The 'N' is formed by a thick diagonal bar and a vertical bar, while the 'O' is a thick circular ring. The background is filled with horizontal gray lines, some of which are partially obscured by the 'NO' graphic.

TO DOWNLOAD OR ORDER CATALOGS,
VISIT WWW.NOSHOK.COM

Quality Policy

NOSHOK

is committed to providing a high degree of value and continually improving processes to improve customer satisfaction by focusing on customer requirements for the design, manufacture and distribution of pressure, temperature, and force measurement instruments along with needle and manifold valves including custom manifold systems for industrial applications.

All from world class technology.

Combined with real-world stamina.

The highest value with the industry's best warranty.

And all from a company with a 45+ year record of customer satisfaction.

All from your Single Source Instrumentation Company.



Corporate Headquarters

1010 West Bagley Road
Berea, Ohio 44017
Ph: 440.243.0888
Fax: 440.243.3472
E-mail: noshok@noshok.com
Web: www.noshok.com

