



EXOTIC
AUTOMATION & SUPPLY

Omler DeCoring Hammers - Maintenance and Repair Guidelines

For Servicing Omler De-Coring Hammers, please reference the appropriate Omler User Manual. The User Manuals for RVC70 and AF1470 are included for your reference.

- [Click here to view the RVC70 User Manual](#)
- [Click here to view the AF1470 User Manual](#)

Common Causes of Failure

Omler De-Coring Hammers operate in very challenging atmospheres. Sand, lack of lubrication, heat and misalignment add to the challenges and may cause premature failure of the Hammer. Care should be taken to assure that the Hammer is properly aligned with the part to be de-cored and that the Hammer has adequate lubrication. The decoring Hammer, depending on operating pressure, will cycle as many as 25 times per second. Assuming a 30 second de-coring cycle, the Hammer may cycle as many as 750 times per de-coring cycle. Because of potential heat generation, adequate lubrication is essential.

Care must be taken to keep sand from entering the Hammer. Sand inside the Hammer jams reciprocating parts and prematurely wears internal components. If sand from the core cannot be avoided, an "Air Head" (Part # P.15A) may help to protect the seal area from ingesting sand and protect the O.D. of the cylinder (Part # P.5).

All standard Exotic Automation repairs include the replacement of soft seals P.12, P.14, P.1/N and P.2/N fasteners, P.3/N washers and P.4/N Pins. All other parts are replaced as needed.

Primary and Frequently Replaced Omler Parts

P.5 Cylinder-New Part:



P.5 Cylinder-Worn Part:



P.6 Piston-New Part



P.6 Piston-Worn Part



The piston (P.6) may become lodged inside the bore of the cylinder due to heat and/or lack of adequate lubrication. Sand may become lodged between the piston and the bore of the cylinder, accelerating wear. Misalignment of the Beater may cause premature wear at the nose of the piston.

The O.D. surface of the Cylinder (P.5) may become damaged by the (P.1/N) Cylinder Scraper, located inside the (P.15) Upper Cover. If sand becomes lodged in the Scraper, the abrasion causes wear on the Cylinder O.D, compromising the effectiveness of the Scraper and permitting sand to enter the Jacket Spring Chamber. Wear on the nose of the Cylinder is from the shoulder of the Beater as the Beater is impacted by the reciprocating Piston.

P.5 and P.6 are not available as individual parts. They are only available as an assembly to assure the close tolerance required between the bore of the cylinder and the reciprocating piston.

P.15 Upper Cover

New Upper Cover



Worn Upper Cover



The Upper Cover becomes worn due to misalignment of the Beater. If the Beater is not perpendicular to the impact point of the casting, a side load is created that causes wear on the bearing point provided by the Upper Cover. This side load causes the bearing point to become out of round and reduces the effectiveness of the P.1N Cylinder Scraper. The ineffective, out of round Scraper will collect sand and cause accelerated wear on the O.D. of the P.5 Cylinder and allow sand to enter the Hammer. This wear is often difficult to see. Tools maybe required to determine if the bearing point is out of round. Wear on one side of the Scraper is a visual indication of side load.

P.9 Outer Valve

New Outer Valve



Worn Outer Valve



P.10 Inner Valve

New Inner Valve



Worn Inner Valve



The Inner Valve reciprocates inside of the Outer Valve causing a stroke of the Piston. Like the Piston, the Inner Valve may reciprocate up to 25 time per second. A typical 30 second cycle would see the Piston and the Inner Valve reciprocating 750 times. This rapid reciprocation of the Inner Valve requires an adequate volume of lubrication (1 drop every 3-4 seconds). The close tolerance between the Inner and Outer Valves makes these parts vulnerable to heat generation and sand ingress. Wear of these parts is difficult to determine visually but wear increases air consumption and leakage and reduces performance.

P.3A Spring

New Spring



Worn Spring



The Spring (P.3A) causes the Beater to retract away from the casting. It is compressed when the Beater extends to the casting. If the extend stroke to the casting is too far, the Spring over compresses and buckles against the I.D. of the Jacket causing wear to the Jacket and to the Spring. If sand is present in the Jacket, Spring wear is accelerated.

USER MANUAL
DE-CORING HAMMER
Mod. RVC 70 / RVC 70-MBL / RVC 70-MBR



TECHNICAL FEATURES

Mod. RVC 70

Air pressure (bar)	4	5	6*
Frequency (Hz)	18,4	19	20,5
Frequency (beats/min)	1070	1140	1230
Air consumption (l/min)	840	905	1040

Tolerance ± 1 Hz

Weight of hammer without beater	Kg	24
Air inlet coupling	G	3/4" o \varnothing ext 20mm
Air outlet coupling	G	3/4" o \varnothing int 16mm
Max beating distance	mm	150
Recommended beating distance	mm	70

Mod. RVC 70-MBL

Air pressure (bar)	4	5	6*
Frequency (Hz)	19	20,5	21,5
Frequency (beats/min)	1140	1230	1290
Air consumption (l/min)	846	932	942

Tolerance ± 1 Hz

Weight of hammer without beater	Kg	24
Air inlet coupling	G	3/4" o \varnothing ext 20mm
Air outlet coupling	G	3/4" o \varnothing int 16mm
Max beating distance	mm	150
Recommended beating distance	mm	70

Mod. RVC 70-MBR

Air pressure (bar)	4	5	6*
Frequency (Hz)	20,5	23	25
Frequency (beats/min)	1230	1380	1500
Air Consumption (l/min)	814	922	928

Tolerance ± 1 Hz

Weight of hammer without beater	Kg	24
Air inlet coupling	G	3/4" o \varnothing ext 20mm
Air outlet coupling	G	3/4" o \varnothing int 16mm
Max beating distance	mm	150
Recommended beating distance	mm	70

*Recommended max air pressure 6 bar (87psi)

Tip: hammer performances can be controlled using OMLER 2000 monitoring system (Thor V2.0 + RB2000)

DE-CORING HAMMER

Mod. RVC 70 / RVC 70-MBL / RVC 70-MBR

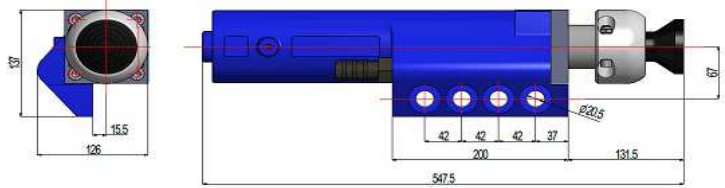
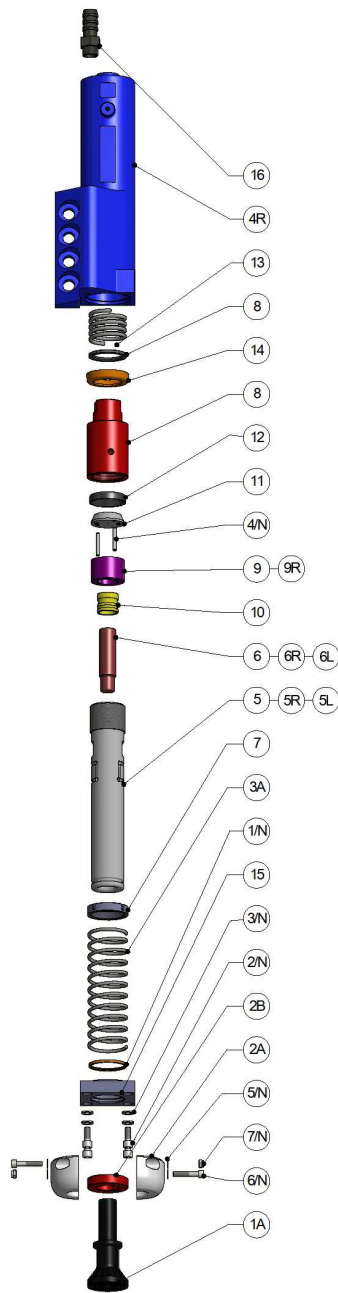

PART Nr.	DESCRIPTION
P.1A	● SPHERICAL BEATER
P.2A	● PLASTIC BUSHING
P.2B	● SPACER
P.3A	/ SPRING
P.4R	◆ JACKET
P.5-6	* CYLINDER+PISTON Mod. RVC 70
P.5-6L	* CYLINDER+PISTON Mod. RVC 70-MBL
P.5-6R	* CYLINDER+PISTON Mod. RVC 70-MBR
P.7	* RING NUT
P.8	* HEAD
P.9	* OUTER VALVE Mod. RVC 70, Mod. RVC 70 MBL
P.9R	* OUTER VALVE Mod. RVC 70-MBR
P.10	* INNER VALVE
P.11	* COVER VALVE
P.12	- UPPER GASKET
P.13	/ SHOCK ABSORBER SPRING
P.14	- LEATHER GASKET
P.15	- UPPER COVER
P.16	- RUBBER COUPLING 3/4"
P.1/N	- CYLINDER SCRAPER P6-56
P.2/N	- SCREW TCEI M10X25
P.3/N	- WASHER SCHNORR ϕ 10
P.4/N	- ELASTIC PINS 6X45
P.5/N	- WASHER SCHNORR ϕ 8
P.6/N	- SCREW T.C.E.I. M8X45
P.7/N	- NUT M8

- = Lifetime depends on the working conditions, such as the temperature of the part to be de-cored
 - / = Needs replacement after 1500 working hours, but, in case it works with wrong distance between beater and part to be de-cored, it needs to be replaced after 1000 working hours
 - * = With preventive maintenance (after 500 working hours, or a little longer) they just need to be repaired, otherwise they have to be replaced
 - = Need replacement at each maintenance operation
 - ◆ = Can be replaced exclusively by and at OMLER 2000
- THE FOREGOING, PROVIDED THAT THE WORKING CONDITIONS WE SUGGEST IN THE USER MANUAL ARE COMPLIED WITH

DE-CORING HAMMER

Mod. RVC 70 / RVC 70-MBL / RVC 70-MBR

GENERAL PRINCIPLES

De-coring hammers must be regularly lubricated using oil for pneumatic tools. We recommend the use of the lubricant MOBIL ALMO 525. Every hammer has to be lubricated separately (one drop every 3-4 seconds for a 20-30 seconds cycle).

If you don't use the de-coring hammer for a long period of time, you must clean it inside using degreaser.

Vibrators must be checked and cleaned after about 500 real working hours (sum of the de-coring cycle seconds) by pouring degreaser liquid into the air inlet. You do not need to take the vibrators out of the de-coring cabin.

All the above mentioned provided that the suggested in this user manual working conditions are complied with.

DO NOT use of the hammers without beater or without casting.

To increase the correct operation of every hammer use pipes with the same length.

PREVENTIVE MAINTENANCE OPERATIONS

After a working time of about 250 real working hours (sum of the de-coring cycle seconds), or earlier, preventive maintenance operations are to be performed by inspecting and cleaning the vibrators, by pouring degreaser liquid into the air inlet. You do not need to take the vibrators out of the de-coring cabin.

MAINTENANCE

Hammers have to be disassembled by keeping up with the following procedure.

Check the conditions of the single parts, clean them or if necessary replace them.

Proceed with re-assembly procedure indicated in the specific section.

After their re-assembly they have to be lubricated using the lubricant MOBIL ALMO 525 for pneumatic tools.

Warning: use exclusively original spare parts from O.M.LER 2000.

The use of non-original spare parts could reduce the safety and perfect working of the hammers and increase maintenance operations. The company O.M.LER 2000 will not be liable for any malfunction of vibrators resulting from using of non-original spare parts

FOR YOUR SAFETY

Follow carefully this user manual.

When the hammers are not in operation, always cut their air supply.

During operation hammers generate a noise above the minimum allowed threshold (85dB). ALWAYS use acoustic protection tools.

AIR SUPPLY

In order to protect hammers against deterioration, contamination and oxidation, they have to be supplied with compressed filtered dried and lubricated air.

All fittings, connecting lines and hoses must be properly sized for the required air pressure and volume to avoid narrowing in air supply lines.

* Note: Mobil Almo 525 ISO VG 46 is the lubricating oil used and recommended
Alternative oils: BP ENERGOL RD E 46; SHELL TORCULA 46; TOTAL PNEUMA 46

DISASSEMBLY PROCEDURE

Step	OPERATIONS	NOTES
1	Loosen the 4 screws M10x25 (P.2/N) and remove upper cover (P.15)	Caution: spring (P.3A) might leap out
2	Remove cylinder scraper P6-56 (P.1/N)	
3	Take cylinder set out of jacket (P.4R) including following parts: P.5-6 (mod. RVC 70); P.5-6L (mod. RVC 70-MBL); P.5-6R (mod. RVC 70-MBR); P.7; P.8; P.9 (mod. RVC 70); P.9L (mod. RVC 70-MBL); P.9R (mod. RVC 70-MBR); P.10; P.11; P.12; P.13; P.14	
4	Remove shock absorber spring (P.13)	Be careful during spring extraction
5	Clamp cylinder set	Use the two flat surfaces of the cylinder (P.5)
6	Loosen ring nut (P.7)	Use a sector spanner. Caution! Medium Strength Thread Locker in mod. RVC-70 MBL and mod. RVC-70 MBR to avoid breaks
7	Loosen cylinder (P.5-6 mod. RVC 70; P.5-6L mod. RVC 70-MBL; P.5-6R mod. RVC 70-MBR) from head (P.8)	Use the two flat surfaces of the head (P.8). This operation should be carried out by means of a hydraulic equipment designed by OMLER 2000
8	Remove following parts: cover valve (P.11), inner valve (P.10), outer valve (P.9 mod. RVC 70; P.9L mod. RVC 70-MBL; P.9R mod. RVC 70-MBR) and elastic pins 4/N (in outer valve).	
9	Check condition of parts and clean all parts. Replace them if necessary. Check surfaces of piston and cylinder (P.5-6 mod. RVC 70; P.5-6L mod. RVC 70-MBL; P.5-6R mod. RVC 70-MBR), outer valve (P.9 mod. RVC 70; P.9L mod. RVC 70-MBL; P.9R mod. RVC 70-MBR), and inner valve (P.10). They mustn't be damaged	

RE-ASSEMBLY PROCEDURE

Step.	OPERATION	NOTES
1	Assemble piston and cylinder (P.5-6 mod. RVC 70; P.5-6L mod. RVC 70-MBL; P.5-6R mod. RVC 70-MBR)	Lubricate with specific oil*
2	Assemble elastic pins (P.4/N) in the outer valve (P.9 mod. RVC 70; P.9L mod. RVC 70-MBL; P.9R mod. RVC 70-MBR)	Lubricate with specific oil*
3	Assemble inner valve (P.10) in the outer valve (P.9 mod. RVC 70; P.9L mod. RVC 70-MBL; P.9R mod. RVC 70-MBR)	Lubricate with specific oil*
4	Assemble outer valve (P.9 mod. RVC 70; P.9L mod. RVC 70-MBL; P.9R mod. RVC 70-MBR) in the cylinder (P.5)	Lubricate with specific oil*
5	Assemble cover valve (P.11) on the outer valve (P.9 mod. RVC 70; P.9L mod. RVC 70-MBL; P.9R mod. RVC 70-MBR)	Lubricate with specific oil*
6	Insert upper gasket (P.12), previously lubricated, into head (P.8)*	Lubricate with specific oil*
7	Clamp head (P.8) on cylinder (P.5) previously assembled with parts: P.9 (mod. RVC 70); P.9L (mod. RVC 70-MBL); P.9R (mod. RVC 70-MBR); P.10; P.11. Insert ring nut (P.7)	Lubricate with specific oil*
8	Block cylinder set	Use hydraulic tool
9	Tighten ring nut (P.7) on cylinder (P.5) to lock head (P.8)	Use a sector spanner
10	Assemble leather gasket (P.14) with washer (P.8) and insert shock absorber spring (P.13)	Use specific tool
11	Assemble cylinder scraper (P.1/N) in upper cover (P.15)	Lubricate the gasket with specific oil*
12	Insert cylinder set P.5-6 (mod. RVC 70); P.5-6L (mod. RVC 70-MBL); P.5-6R (mod. RVC 70-MBR); P.7; P.8; P.9 (mod. RVC 70); P.9L (mod. RVC 70-MBL); P.9R (mod. RVC 70-MBR); P.10; P.11; P.12; P.13; P.14; P.4/N into the jacket (P.4R)	Lubricate inner side of jacket (P.4R) and outer side of cylinder (P.5-6 mod. RVC 70; P.5-6L mod. RVC 70-MBL; P.5-6R mod. RVC 70-MBR) with specific oil*
13	Insert spring (P.3/A) into jacket (P.4R) and then close with upper cover (P.15)	Press upper cover (P.15) onto jacket (P.4R)
14	Tighten the 4 screws TCEI M10x25 (P.2/N) with washer \varnothing 10 (P.3/N)	Use a dynamometer key

FAILURE CAUSES

No.	FAILURES	CAUSES	REMEDIES
1	Jammed piston (P.6)	Scarce lubrication or dirt in cylinder (P.5-6 mod. RVC 70; P.5-6L mod. RVC 70-MBL; P.5-6R mod. RVC 70-MBR)	Check lubrication and air pressure of the whole system (air pressure must be between 3 and 6 bar) (see technical features)
2	Jammed inner valve (P.10)	Scarce lubrication or dirt in outer valve (P.9 mod. RVC 70; P.9L mod. RVC 70-MBL; P.9R mod. RVC 70-MBR)	Same as 1
3	Incorrect inner valve (P.10) functioning	Too much oil in outer valve (P.9 mod. RVC 70; P.9L mod. RVC 70-MBL; P.9R mod. RVC 70-MBR)	Check level oil (drop/sec)
4	Cylinder (P.5) sticking in the upper cover (P.15)	<ul style="list-style-type: none"> a) Sand between cylinder (P.5) and upper cover (P.15) b) No casting presence c) Vibrator not perpendicular to the casting 	Disassemble hammer for maintenance
5	Cylinder breaking	<ul style="list-style-type: none"> a) Scarce lubrication b) Vibrator not perpendicular to the casting c) Wrong beating distance 	Disassemble hammer for maintenance
6	Breaking of the head (P.8)	Breaking or leaping out of shock absorber spring (P.13)	Check spring (P.13) and replace head (P.8)

* N.B: Mobil Almo 525 ISO VG 46 is the lubricated oil used and recommended
Alternative oils: BP ENERGOL RD E 46; SHELL TORCULA 46; TOTAL PNEUMA 46

[O.M.LER 2000 S.r.l. Tecnologie Meccaniche Lerda](http://www.omler2000.com)

Str. Montà della Radice, 15/A – 12042 Bandito – BRA (CN) – Italy – Tel. +39 0172 457741 – Fax +39 0172 457579
P.IVA IT02758610048 – R.E.A. 235047 Cuneo – R.I. 02758610048 Cuneo – Capitale Sociale € 30.987,00 I.V.

info@omler2000.com – www.omler2000.com

USER MANUAL
DE-CORING HAMMER
AF1470, AF1470-MBL, AF1470-MBR



TECHNICAL FEATURES

Mod. AF1470

Air pressure (bar)	4	5	6*
Frequency (Hz)	19	20	22
Air consumption (l/min)	900	1150	1250

Weight of hammer without beater	Kg	18,5
Air inlet coupling	G	3/4"
Air outlet coupling	G	3/4"
Max beating distance	mm	120
Recommended beating distance	mm	70

Mod. AF1470-MBL

Air pressure (bar)	4	5	6*
Frequency (Hz)	20	21,5	22,5
Air consumption (l/min)	950	1200	1300

Weight of hammer without beater	Kg	18,5
Air inlet coupling	G	3/4"
Air outlet coupling	G	3/4"
Max beating distance	mm	120
Recommended beating distance	mm	70

Mod. AF1470-MBR

Air pressure (bar)	4	5	6*
Frequency (Hz)	21	23	25
Air Consumption (l/min)	1000	1250	1500

Weight of hammer without beater	Kg	18,5
Air inlet coupling	G	3/4"
Air outlet coupling	G	3/4"
Max beating distance	mm	120
Recommended beating distance	mm	70

*Recommended max air pressure 6 bar (87psi)

Tip: hammer performances can be controlled using OMLER 2000 monitoring system (Thor V3.0 + RB2000)

DE-CORING HAMMER

AF1470 / AF1470-MBL / AF1470-MBR

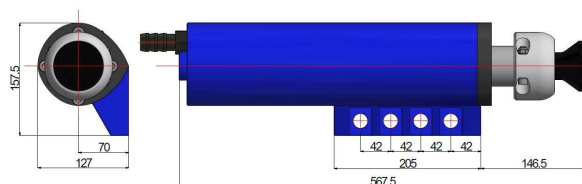
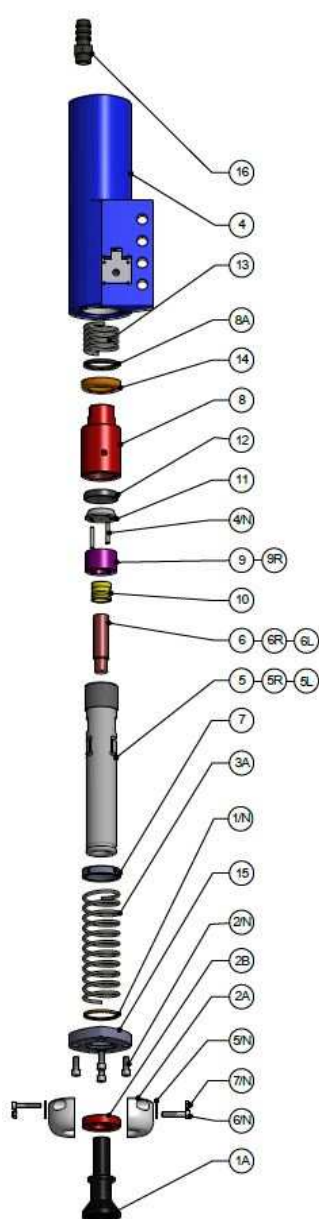

PARTS

ART. Nr.	PART Nr.		DESCRIPTION
S-L1A	P.1A	●	SPHERICAL BEATER
S-L2A	P.2A	●	PLASTIC BUSHING
S-L2B	P.2B	●	SPACER
S-L3	P.3A	/	SPRING
S-L4R	AF4	◆	JACKET
S-L5-6	P.5-6	*	CYLINDER+PISTON Mod. AF1470
S-L5-6L	P.5-6L	*	CYLINDER+PISTON Mod. AF1470-MBL
S-L5-6R	P.5-6R	*	CYLINDER+PISTON Mod. AF1470-MBR
S-L7	P.7	*	RING NUT
S-L8	P.8	*	HEAD
S-L9	P.9	*	OUTER VALVE Mod. AF1470, Mod. AF1470 MBL
S-L9R	P.9R	*	OUTER VALVE Mod. AF1470-MBR
S-L10	P.10	*	INNER VALVE
S-L11	P.11	*	COVER VALVE
S-L12	P.12	-	UPPER GASKET
S-L13	P.13	/	SHOCK ABSORBER SPRING
S-L14	P.14	-	LEATHER GASKET
S-L15	AF15	-	UPPER COVER
S-L16	P.16	-	RUBBER COUPLING 3/4"
S-L19	P.1/N	-	CYLINDER SCRAPER P6-56
S-L20	P.2/N	-	SCREW TCEI M10X25
S-L21	P.3/N	-	WASHER SCHNORR \varnothing 10
S-L22	P.4/N	-	ELASTIC PINS 6X45
S-L23	P.5/N	-	WASHER SCHNORR \varnothing 8
S-L24	P.6/N	-	SCREW T.C.E.I. M8X45
S-L25	P.7/N	-	NUT M8

- = Lifetime depends on the working conditions including the temperature of the part to be de-cored
 - / = Needs replacement after 1500 working hours. If the beating distance requirement is not observed, replacement is required after 1000 working hours
 - * = With preventive maintenance (after 500 working hours) inspection and evaluation is required, otherwise parts must be replaced
 - = Need replacement at each maintenance operation
 - ◆ = Can be replaced exclusively by, or at, OMLER 2000 or an Omler 2000 authorized service center.
- Installation and operation as described in this User Manual is essential to assure optimal performance and service life.

DE-CORING HAMMER

AF1470 / AF1470-MBL / AF1470-MBR

GENERAL PRINCIPLES

De-coring hammers must be regularly lubricated using pneumatic tool oil.

We recommend the use of MOBIL ALMO 525. Every hammer has to be lubricated separately (one drop every 3-4 seconds for a 20-30 seconds cycle).

If you don't use the de-coring hammer for a long period of time, you must clean it inside using degreaser.

Vibrators must be checked and cleaned after about 500 real working hours (sum of the de-coring cycle seconds) by spraying degreaser liquid into the air inlet. You do not need to take the vibrators out of the de-coring cabin.

All the above mentioned provided that the suggested in this user manual working conditions are complied with.

DO NOT use the hammers without a beater or without a casting.

To enhance the operation of multiple hammer installations, use pipes with the same length.

PREVENTIVE MAINTENANCE OPERATIONS

After a working time of about 250 real working hours (sum of the de-coring cycle seconds), or earlier, preventive maintenance operations are to be performed by inspecting and cleaning the vibrators, by degreaser liquid into the air inlet. You do not need to take the vibrators out of the de-coring cabin.

MAINTENANCE

When disassembling and re-assembling the Hammer, the following steps should be followed by experienced maintenance personnel.

- Check the conditions of the single parts, clean them or if necessary replace them.
- Proceed with re-assembly procedure indicated in the specific section.
- After their re-assembly they have to be lubricated using the lubricant MOBIL ALMO 525 for pneumatic tools.

Warning: use exclusively, original spare parts from O.M.LER 2000.

The use of non-original spare parts could affect the safe operation of the Hammer and increase maintenance requirements.

O.M.LER 2000 will not be liable for any malfunction of Hammers resulting from the use of non-original spare parts.

FOR YOUR SAFETY

- Carefully follow the instructions in this this User Manual.
- When the Hammers are not in operation, always remove their air supply.
- During operation Hammers generate a noise above the minimum allowed threshold (85dB). ALWAYS use acoustic protection tools.

AIR SUPPLY

In order to protect Hammers against deterioration, contamination and oxidation, they must be supplied with filtered, dried, and lubricated compressed air.

All fittings, connecting lines and hoses must be properly sized for the required air pressure and volume to avoid restricting the air supply lines.

* Note: Mobil Almo 525 ISO VG 46 is the lubricating oil used and recommended
Alternative oils: BP ENERGOL RD E 46; SHELL TORCULA 46; TOTAL PNEUMA 46

DISASSEMBLY PROCEDURE

Step	OPERATIONS	NOTES
1	Loosen the 4 screws M10x25 (P.2/N) and remove upper cover (P.15)	Caution: spring (P.3A) might leap out
2	Remove cylinder scraper P6-56 (P.1/N)	
3	Take cylinder set out of jacket (AF4) including following parts: P.5-6 (mod. AF1470); P.5-6L (mod. AF1470-MBL); P.5-6R (mod. AF1470-MBR); P.7; P.8; P.9 (mod. AF1470); P.9L (mod. AF1470-MBL); P.9R (mod. AF1470-MBR); P.10; P.11; P.12; P.13; P.14	
4	Remove shock absorber spring (P.13)	Be careful during spring extraction
5	Clamp cylinder set	Use the two flat surfaces of the cylinder (P.5)
6	Loosen ring nut (P.7)	Use a sector spanner. Caution! Medium Strength Thread Locker in mod. RVC-70 MBL and mod. AF1470-MBR to avoid breaks
7	Loosen cylinder (P.5-6 mod. AF1470; P.5-6L mod. AF1470-MBL; P.5-6R mod. AF1470-MBR) from head (P.8)	Use the two flat surfaces of the head (P.8). This operation should be carried out by means of a hydraulic equipment designed by OMLER 2000
8	Remove following parts: cover valve (P.11), inner valve (P.10), outer valve (P.9 mod. RVC 70; P.9L mod. AF14-MBL; P.9R mod. AF1470-MBR) and elastic pins 4/N (in outer valve).	
9	Check condition of parts and clean all parts. Replace them if necessary. Check surfaces of piston and cylinder (P.5-6 mod. AF1470; P.5-6L mod. AF1470-MBL; P.5-6R mod. AF1470-MBR), outer valve (P.9 mod. AF1470; P.9L mod. AF1470-MBL; P.9R mod. AF1470-MBR), and inner valve (P.10). They mustn't be damaged	

RE-ASSEMBLY PROCEDURE

Step.	OPERATION	NOTES
1	Assemble piston and cylinder (P.5-6 mod. AF1470; P.5-6L mod. AF1470-MBL; P.5-6R mod. AF1470-MBR)	Lubricate with specific oil*
2	Assemble elastic pins (P.4/N) in the outer valve (P.9 mod. AF1470; P.9L mod. AF1470-MBL; P.9R mod. AF1470-MBR)	Lubricate with specific oil*
3	Assemble inner valve (P.10) in the outer valve (P.9 mod. RVC 70; P.9L mod. AF1470-MBL; P.9R mod. AF1470-MBR)	Lubricate with specific oil*
4	Assemble outer valve (P.9 mod. RVC 70; P.9L mod. RVC 70-MBL; P.9R mod. AF1470-MBR) in the cylinder (P.5)	Lubricate with specific oil*
5	Assemble cover valve (P.11) on the outer valve (P.9 mod. AF1470; P.9L mod. AF1470-MBL; P.9R mod. AF1470-MBR)	Lubricate with specific oil*
6	Insert upper gasket (P.12), previously lubricated, into head (P.8)*	Lubricate with specific oil*
7	Clamp head (P.8) on cylinder (P.5) previously assembled with parts: P.9 (mod. AF1470); P.9L (mod. AF1470-MBL); P.9R (mod. AF1470-MBR); P.10; P.11. Insert ring nut (P.7)	Lubricate with specific oil*
8	Block cylinder set	Use hydraulic tool
9	Tighten ring nut (P.7) on cylinder (P.5) to lock head (P.8)	Use a sector spanner
10	Assemble leather gasket (P.14) with washer (P.8) and insert shock absorber spring (P.13)	Use specific tool
11	Assemble cylinder scraper (P.1/N) in upper cover (AF15)	Lubricate the gasket with specific oil*
12	Insert cylinder set P.5-6 (mod. AF1470); P.5-6L (mod. AF1470-MBL); P.5-6R (mod. AF1470-MBR); P.7; P.8; P.9 (mod. AF1470); P.9L (mod. AF1470-MBL); P.9R (mod. AF1470-MBR); P.10; P.11; P.12; P.13; P.14; P.4/N into the jacket (AF15)	Lubricate inner side of jacket (P.4R) and outer side of cylinder (P.5-6 mod. AF1470; P.5-6L mod. AF1470-MBL; P.5-6R mod. AF1470-MBR) with specific oil*
13	Insert spring (P.3/A) into jacket (P.4R) and then close with upper cover (P.15)	Press upper cover (P.15) onto jacket (P.4R)
14	Tighten the 4 screws TCEI M10x25 (P.2/N) with washer Ø 10 (P.3/N)	Use a dynamometer key

FAILURE CAUSES

No.	FAILURES	CAUSES	REMEDIES
1	Jammed piston (P.6)	Scarce lubrication or dirt in cylinder (P.5-6 mod. ; P.5-6L mod. AF1470-MBL; P.5-6R mod. AF1470-MBR)	Check lubrication and air pressure of the whole system (air pressure must be between 3 and 6 bar) (see technical features)
2	Jammed inner valve (P.10)	Scarce lubrication or dirt in outer valve (P.9 mod. AF1470; P.9L mod. AF1470-MBL; P.9R mod. AF1470-MBR)	Same as 1
3	Incorrect inner valve (P.10) functioning	Too much oil in outer valve (P.9 mod. AF1470; P.9L mod. AF1470-MBL; P.9R mod. AF1470-MBR)	Check level oil (drop/sec)
4	Cylinder (P.5) sticking in the upper cover (P.15)	<ul style="list-style-type: none"> a) Sand between cylinder (P.5) and upper cover (AF15) b) No casting presence c) Vibrator not perpendicular to the casting 	Disassemble hammer for maintenance
5	Cylinder breaking	<ul style="list-style-type: none"> a) Scarce lubrication b) Vibrator not perpendicular to the casting c) Wrong beating distance 	Disassemble hammer for maintenance
6	Breaking of the head (P.8)	Breaking or leaping out of shock absorber spring (P.13)	Check spring (P.13) and replace head (P.8)

* N.B: Mobil Almo 525 ISO VG 46 is the lubricated oil used and recommended
Alternative oils: BP ENERGOL RD E 46; SHELL TORCULA 46; TOTAL PNEUMA 46

O.M.LER 2000 S.r.l. Tecnologie Meccaniche Lerda

Str. Montà della Radice, 15/A – 12042 Bandito – BRA (CN) – Italy – Tel. +39 0172 457741 – Fax +39 0172 457579
P.IVA IT02758610048 – R.E.A. 235047 Cuneo – R.I. 02758610048 Cuneo – Capitale Sociale € 30.987,00 I.V.

info@omier2000.com – www.omier2000.com