

aerospace
climate control
electromechanical
filtration
fluid & gas handling
hydraulics
pneumatics
process control
welding & shielding

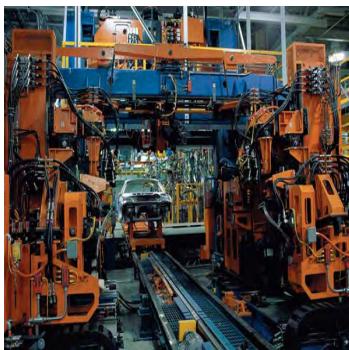

Automotive Filters and Fluid Contamination Monitoring

Solutions for the Automotive Industry



ENGINEERING YOUR SUCCESS.

Contents

Parker Automotive Filter Catalog

DIN Filters

High Pressure

FDA, FDB.....3

Low Pressure Filters

10DT, 16DT, 25DT..... 11

40RF, 50RF 15

SAE Series

High Pressure Filters

HF15P Series 17

HF3 Series.....21

HF3 Duplex.....23

HF4 Series.....25

HF4 Duplex.....28

Low Pressure Return Filters

HF2 Series – 15CN Return 33

HF3 Series – 40CN Return 37

HF4 Series – IL4/DIL4 39

High Flow Filters

IL8/HDIL8 Filters..... 42

Special Applications Filters

Splash Lube Filter 51

Electrical Information54

Offline Systems

SMR Series..... 56

PVS Series..... 67

Reservoir Equipment

EAB Environmental Air Filters 70

ABL Environmental Air Filters 74

AB Series Reservoir Breathers..... 78

Fluid Condition Monitoring

LaserCM Portable

Particle Counter 81

SPS – Single Point Sampler..... 88

System 20 – Inline Sensors 91

IcountPD – Online Particle Detector 92

Parker Automotive Filters

Providing the products and service our customers expect

A Global Product Range

With this catalog, we offer our automotive customers an easy way to find technical specification and ordering information about Parker hydraulic filtration, fluid contamination monitoring and fluid power products.

Products shown in this catalog have a broad range of applications. Our filter products are particularly designed for hydraulic and lubrication systems and transmissions. The fluid power products are also used in many industries and applications.

Typical applications can vary from road sweepers, fork lift trucks, agriculture harvesting machines, grass cutting equipment, lorry mounted cranes, forestry equipment, press brakes, industrial power units, waste management trucks, drilling equipment, marine, military equipment, paper mills, water treatment and filtration systems.

For more information about our products, send your inquiry to your nearest sales location. See contact information at the back of this catalog.

BSP ports offered in this catalog conform to ISO228.

Supply chain management, service and support

Parker is addressing operation efficiency by expanding the systematic approach called 'Lean Manufacturing.' Value stream analysis, flow manufacturing,

reduced set-ups, manufacturing cell flexibility and fool-proofing systems are all contributing to the continuous improvement in our manufacturing sites. 'Lean' is also expressed in our premier customer service and second-to-none customer partnerships in supply chain management.

Engineering and manufacturing excellence

Parker's manufacturing focus is driven by a number of key elements that affect all areas of the business. People productivity, customer satisfaction, production throughput, quality and lean achievements are the drivers that help Parker achieve ISO9001, QS9000, ISO9001 and ISO14001.

Significant investment by our parent, Parker Hannifin Corporation, continues to give the Filtration Group flexible manufacturing systems, automated test equipment and excellent laboratory test facilities.

New product development programs and on-going product improvement initiatives are vital elements in maintaining a product range that meets customer demands for quality, reliability and engineering excellence.

R & D resources at Parker locations in the U.K., Finland, The Netherlands and the U.S. are both complementary and comprehensive. Including, as examples, Multipass Test

Installations, fatigue test unit, cleanliness service (water detection, special analysis, particle counting and analysis), 3D workstations, Thermal Cycle Test Chamber, Salt Spray and Humidity chambers.

Parker Hannifin Corporation, herewith declares that Parker Hydraulic Filtration products are intended to be incorporated into machinery covered by Directive 89/392/EEC, as amended and that the following harmonized standards have been applied; EN982, EN292-1, EN292-2.

We furthermore declare that, machinery incorporating Parker Hydraulic Filtration products, is not allowed to be put into service until the machinery has been found and declared to be in conformity with the provisions of Directive 89/392/EEC and with national implementing legislation.

In line with our policy of continuous product improvement, Parker Hannifin Corporation reserves the right to alter product data and specification without notice. This does not affect your statutory rights.

Notes:

- 1. Within this catalog, each product has been allocated an operating temperature and pressure range.*
- 2. The range listed for each filter is dedicated by the materials of construction and the capability of the seals specified.*
- 3. Consideration should also be given to the characteristics of the system fluid when specifying filters for extreme temperature and/or pressure applications.*
- 4. The use of non-Parker replacement elements and parts may invalidate your warranty.*



DIN Series

High Pressure DIN Filters



ENGINEERING YOUR SUCCESS.

FDA, FDB

High Pressure DIN Filters

A range of hydraulic DIN filters to DIN 24550.

Parker's DIN specification high pressure filters utilize the proven high efficiency "Q" media ($\beta_x \geq 200$).

These filters, with a range of bowl lengths, offer exceptional dirt holding capacity for filters with flows up to 65 gpm (250 lpm) and pressures of up to 5,800 psi (400 bar).

With a range of visual and electrical indicators including the 4 LED indicator with two setting points, these filters offer contamination protection for hydraulic systems ranging in use from standard power units to complex automotive systems.



Specification

Maximum Allowable Operating Pressure

5,800 psi (400 bar)
Design factor of safety 3:1 minimum

Operating Temperature

-40°F to 250°F (-40°C to 120°C)

Construction

SG Iron head, Steel Bowl

Fluid Compatibility

Suitable for use with mineral oils, most water glycols and other water based fluids. For other fluids, please consult the Hydraulic Filter Division.

Seals

Head to bowl, diametric with anti-extrusion ring.
Materials - Nitrile.

Bypass valve

98psi \pm 10% (7.0 bar \pm 10%)

Element Condition Indicators (Differential Pressure Type)

- Visual type cartridge, with auto reset.
- Electrical type cartridge, with auto reset and socket to DIN43650.
- 4 LED with 2 set points at 75% & 100%.

Ports



See ordering information table.

Filter element

Microglass III disposable inorganic fiber media. Available as 3, 5, 10 or 20 micron ($\beta_x \geq 200$). Media is supported both up- and downstream and the whole

assembly bonded resulting in a 20 bar collapse rating. End caps and support tube are tin plated giving excellent corrosion protection.

Electrical Indicator ratings

	Electrical	3 LED
Power	20VA	20VA
Current	1A	1A
Voltage	28 Vdc max, 28 Vac (50-60Hz) max	10 - 30V
Plug Pin Code	 <ul style="list-style-type: none"> 1) Common 2) N. Closed 3) N. Open 	

Weights lbs. (kg)

Model	Length 1	Length 2	Length 3
FDA	10.3 (4.7)	12.5 (5.7)	13.6 (6.2)
FDB	36.8 (16.7)	44 (20)	N/A

FDA, FDB

Installation & Element Service Instructions

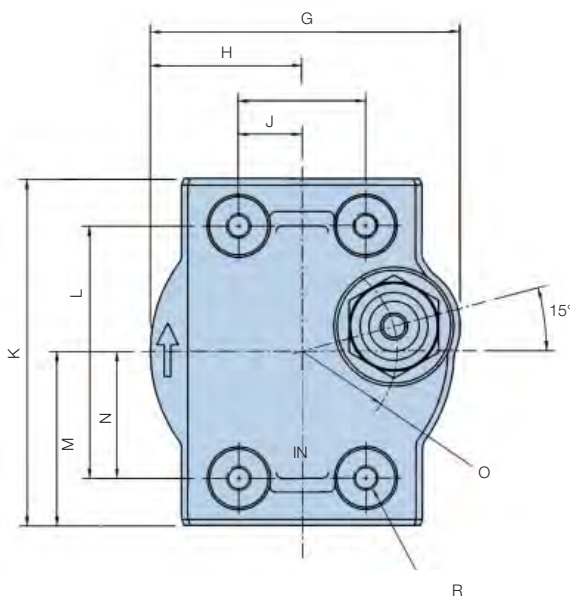
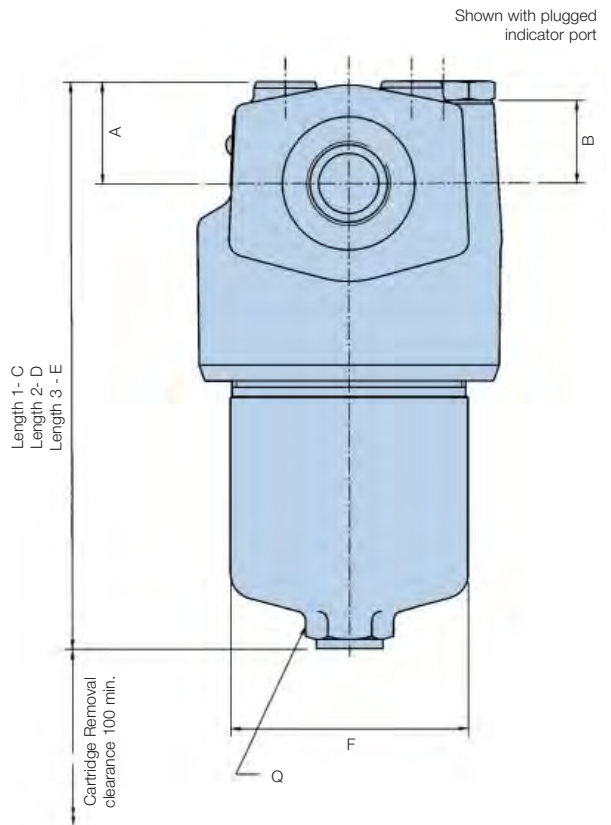

Installation

The FDA and FDB DIN high pressure filters are designed to operate in systems where the operating pressure does not exceed 5,800 psi.

The filter should be mounted with the bowl down and secured to a suitable bracket using the mounting holes provided on the filter head. Ensure that the filter is orientated so that the visual indicator, if fitted, is clearly visible. The arrow stamped on the filter head should coincide with the flow direction.

Element Servicing

Ensure that the hydraulic system is switched off and that the pipework is de-pressurized. Drain fluid from filter bowl by removing bowl drain plug if fitted. With suitable spanner, unscrew the bowl from the filter head revealing the dirty element. Grasp the element and pull downwards with a slight twisting movement to remove. Discard used element and check head and bowl for damage. Clean inside bowl with a cleaning agent (do not use cloth or paper towels).

Check that the appropriate seal is fitted to the element, lubricate and replace the element in the filter head. Replace the head to bowl seal and anti-extrusion ring as shown in the instructions included with the new element, lubricate and refit the bowl to the head. On re-pressurizing the filter check for leaks.

Dimensions

Length	FDA		FDB	
	mm	ins	mm	ins
A	32	1.26	49	1.93
B	26	1.02	39	1.54
C	183	7.20	302	11.89
D	243	9.57	392	15.43
E	333	13.11	N/A	N/A
F	Ø75	Ø2.95	Ø128	Ø5.04
G	98	3.86	160	6.30
H	48	1.89	80	3.15
I	40	1.57	50	1.97
J	20	0.79	25	0.98
K	110	4.33	164	6.46
L	80	3.15	120	4.72
M	55	2.17	82	3.23
N	40	1.57	60	2.36
O	R30	R1.18	R48	R1.89

Filter	Q = Across Flats
FDA	Hexagonal 23.3/24.0 A/F
FDB	Hexagonal 35.5/36.0 A/F

Filter	R = Mounting Holes
FDA	4 Mounting Holes M8 x 1.25 - 6H x 12 Deep
FDB	M10 x 1.5 - 6H x 12 Deep

FDA, FDB

Indicators



FMUX ATEX certified indicator - contact Parker

ΔP Indicator

4 LEDs giving visual indication:

- Green (G): Power ON
- Yellow 1 (Y1): Pre-alarm 1 (presetting 50%)
- Yellow 2 (Y2): Pre-alarm 2 (presetting 75%)
- Red (R): Indication (presetting 100%)

Setting range: 0,5 – 10 bar

Thermal lock-out range: 0°C – 100°C

Includes a microchip with memory logs

FMUF Electronic

Contact configuration

NPN

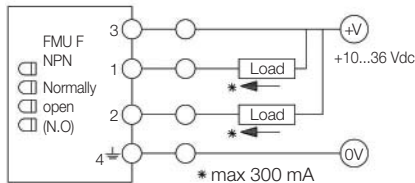

PNP

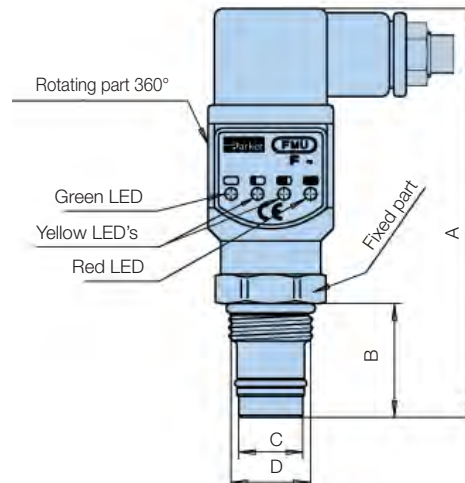
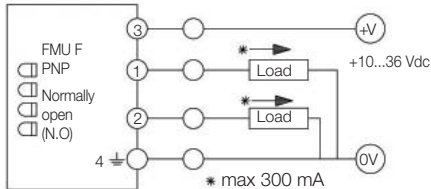

Thermal lock-out (standard setting +68°F (+20°C))

- Indicator operates only when temperature is above setting.
- Green LED is blinking if temperature is lower. (not in U12H)

Ind. press. setting	LED status				Output
	G	Y1	Y2	R	
50%	⊗	⊗			–
75%	⊗	⊗	⊗		2 active
100%	⊗	⊗	⊗	⊗	1 active

Enclosure class	IP65
Electrical connector	DIN 43650, cable connection PG9 or optionally M12 4-pin
Input supply voltage	+10 to 36 Vdc
*Indication output	max. 300 mA/36 Vdc
Output type:	N.O. or N.C./NPN or PNP

Note: Do not connect output terminals 1 or 2 directly (without load) to power supply terminals, because this will damage the equipment.

Ordering Information

Automotive Electronic Indicator Option

Part Number	Description
FMUF5MBMU14H	M12 x 4 Pin Electronic Indicator

	U14M		U14H	
	mm	ins	mm	ins
A	105	4.13	105	4.13
B	32	1.26	32	1.26
C	∅19.78 ±0.06	∅0.77	∅18.83 ±0.06	∅0.74
D	7/8-14 UNF-2A		7/8-14 UNF-2A	

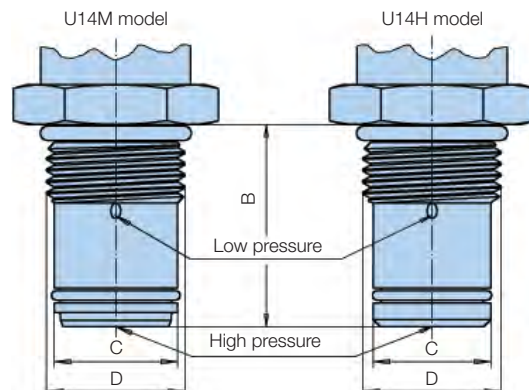

FDA, FDB

Performance

To select the correct housing and element, it is recommended that the ratio between the bypass setting and the differential pressure across the filter with a clean element, at the rated flow, should be at least 2:1.

To find total pressure differential through the filter assembly, add the 'housing only' pressure differential to the 'element only' pressure differential, at the rated flow.

Total ΔP = Housing ΔP + Element ΔP
 Flow curves at 30 cSt viscosity.

Bypass Valve FDA, FDB

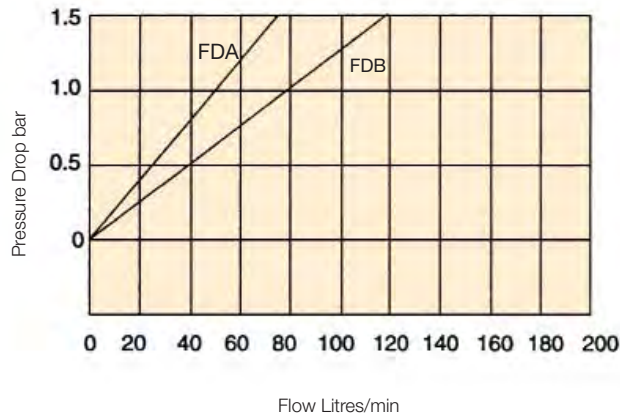

Housings FDA, FDB

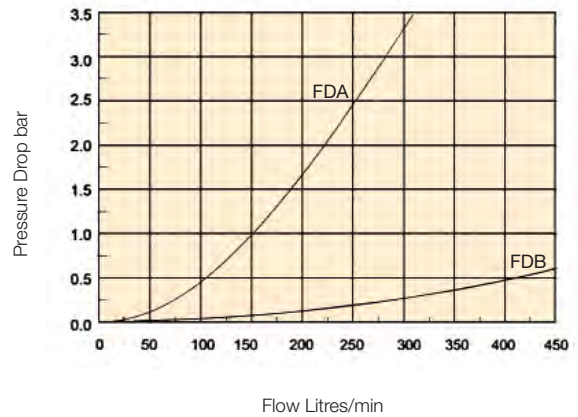

FDA-1 Standard Elements

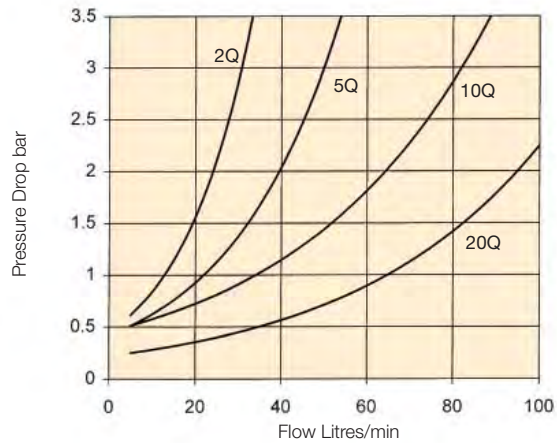

FDA-1 High Collapse Elements

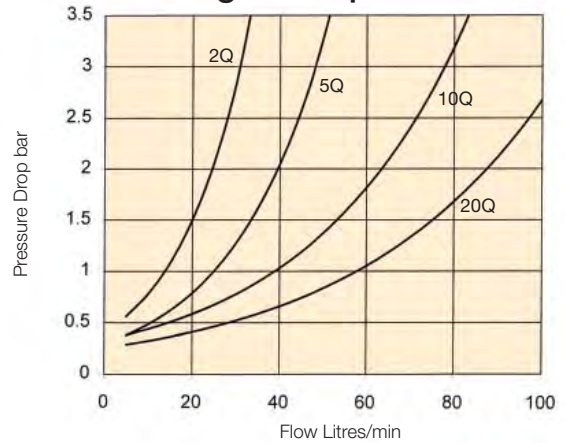

FDA

Performance

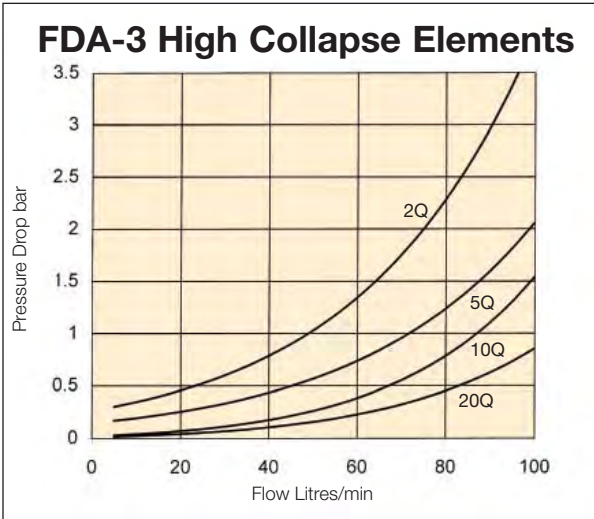
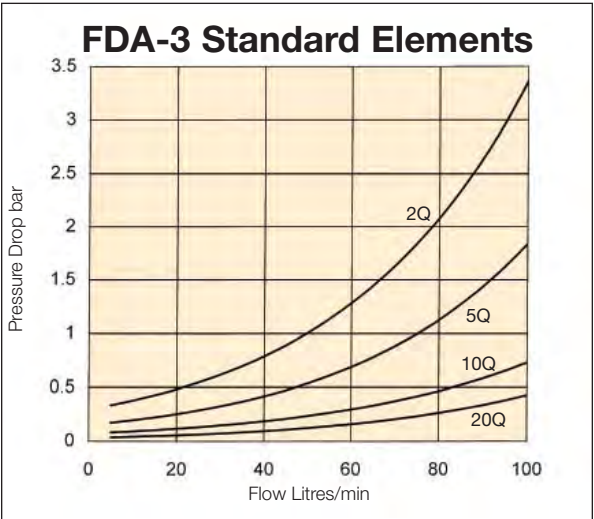
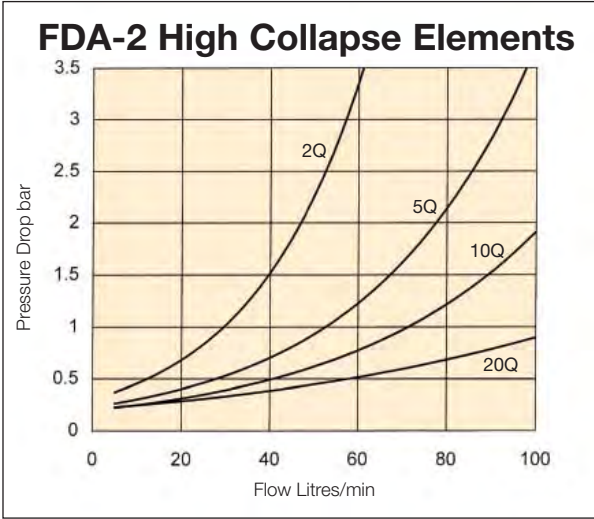
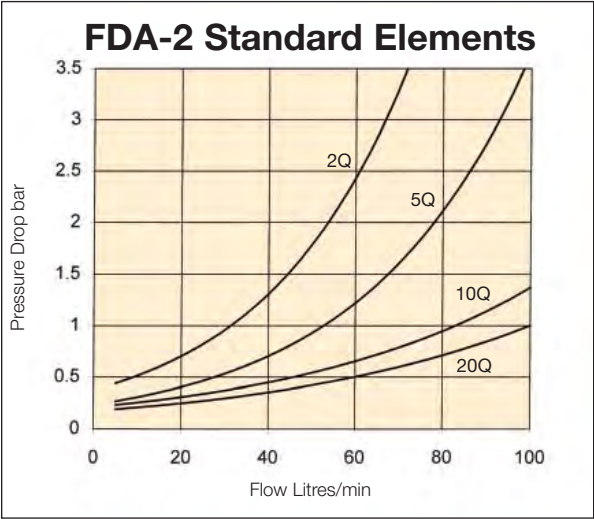

FDB

Performance

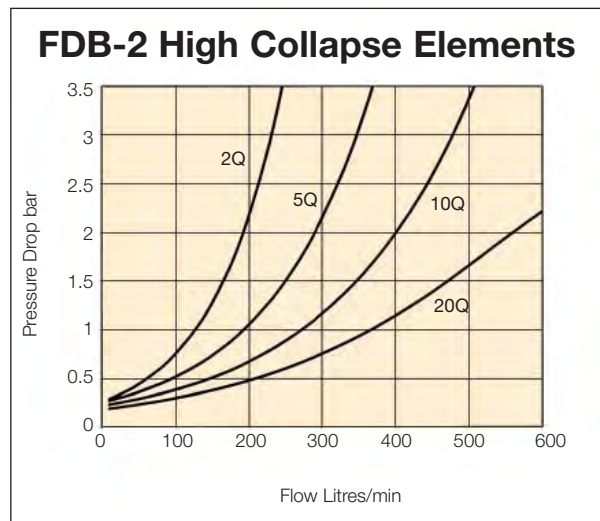
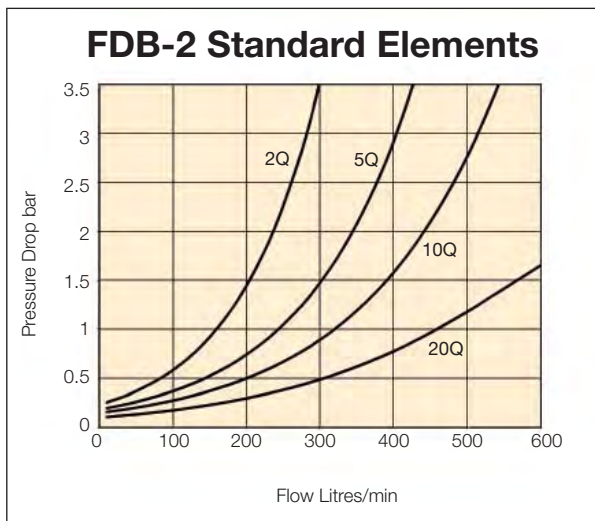
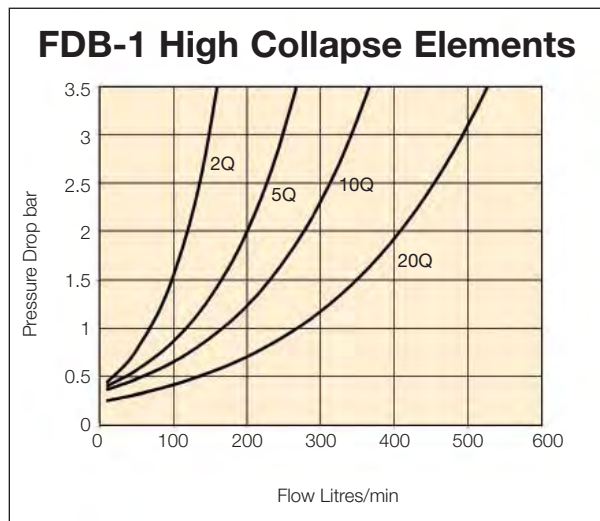
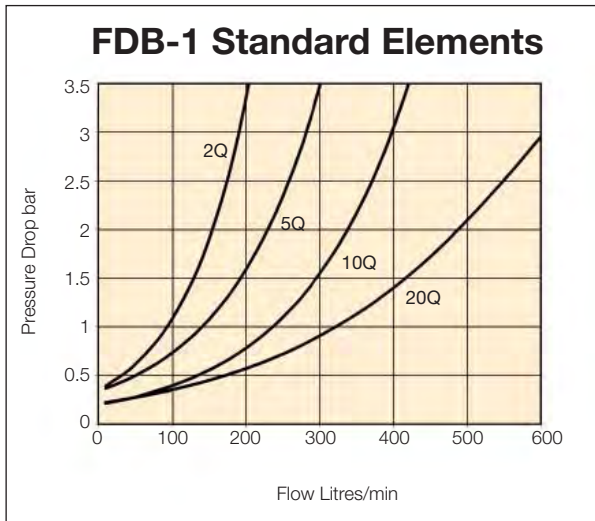

FDA, FDB

Ordering Information

The following filter assemblies are supplied **WITH** bypass, but **WITHOUT** an indicator.

Indicators should be ordered separately.

Standard products table

Part number	Flow (l/min)	Ports (BSP)	Media rating (µ)	Indication	Indicator rating	Bypass rating (bar)	Replacement elements
FDA3A03N98G16Y	100	1"	02		N/A	7 bar	FDAE3A02Q
FDA3A10N98G16Y	100	1"	10		N/A	7 bar	FDAE3A10Q
FDB2A03N98G24Y	250	1 1/2"	02	No	N/A	7 bar	FDBE2A02Q
FDB2A10N98G24Y	250	1 1/2"	10	Indication	N/A	7 bar	FDBE2A10Q
FDB3A03N98G24Y	400	1 1/2"	02		N/A	7 bar	FDBE3A02Q
FDB3A10N98G24Y	400	1 1/2"	10		N/A	7 bar	FDBE3A10Q

The following filter assemblies are supplied **WITH** bypass and 4 LED indicator.

A range of 5,800 psi (400 bar) no bypass, high pressure filters, designed to meet the very specialized requirements of the automotive industry.

Utilizing the same, high quality, high efficiency Microglass III media as fitted to the standard filters, these are designed to be installed where limited flows of unfiltered oil passing through the bypass, as a result of a blocked element, cannot be tolerated.

Standard products table

Part number	Flow (l/min)	Ports (BSP)	Media rating (µ)	Indication	Indicator rating	Bypass rating (bar)	Replacement elements
FDA3A03B98G16Y	100	1"	02		5 bar	7 bar	FDAE3A02Q
FDA3A10B98G16Y	100	1"	10		5 bar	7 bar	FDAE3A10Q
FDB2A03B98G24Y	250	1 1/2"	02	Electronic	5 bar	7 bar	FDBE2A02Q
FDB2A10B98G24Y	250	1 1/2"	10	4 LED	5 bar	7 bar	FDBE2A10Q
FDB3A03B98G24Y	400	1 1/2"	02		5 bar	7 bar	FDBE3A02Q
FDB3A10B98G24Y	400	1 1/2"	10		5 bar	7 bar	FDBE3A10Q

The following filter assemblies are supplied **WITHOUT** bypass **WITH** 4 LED indicator.

Standard products table

Part number	Flow (l/min)	Ports (BSP)	Media rating (µ)	Indication	Indicator rating	Bypass rating (bar)	Replacement elements
FDA3A03HB98G16Y	100	1"	02		5 bar		FDAE3A02Q
FDA3A10HB98G16Y	100	1"	10		5 bar		FDAE3A10Q
FDB2A03HB98G24Y	250	1 1/2"	02	Electronic	5 bar	No	FDBE2A02Q
FDB2A10HB98G24Y	250	1 1/2"	10	4 LED	5 bar	bypass	FDBE2A10Q
FDB3A03HB98G24Y	400	1 1/2"	02		5 bar		FDBE3A02Q
FDB3A10HB98G24Y	400	1 1/2"	10		5 bar		FDBE3A10Q



DIN Series

DIN Low Pressure Filters



ENGINEERING YOUR SUCCESS.

10DT, 16DT, 25DT

Tanktop DIN Filters

A range of hydraulic DIN filters to DIN 24550.

Parker's DT series of DIN specification tanktop filters are available in three size ranges with flows up to 65 gpm (250 lpm).

With two indicators, a visual gauge, and an electrical 3 LED indicator with two setting points, these filters offer contamination protection for hydraulic systems ranging in use from standard power units to complex automotive systems.



Specification

Maximum Allowable Operating Pressure

145 psi (10 bar)

Operating Temperature

14°F to 175°F (-10°C to 80°C)

Construction

Model	10DT	16DT	25DT
Head	Aluminum	Aluminum	Aluminum
Cover	Composite	Aluminum	Aluminum
Bowl	Composite	Steel	Steel

Ports

Model	Port
10DT	G1
16DT	G1 1/4
25DT	G1 1/2

Fluid Compatibility

Suitable for use with mineral oils, most water glycols and other water based fluids. For other fluids, please consult Hydraulic Filter Division Europe.

Seals

Material - Nitrile

Bypass valve

50.8 psi ± 10% (3.5 bar ± 10%)

Element condition indicators

Plugged indicator ports allow the installer to select from a choice of optional visual and/or electrical condition indicators.

3 LED (with 2 set points at 75% & 100%)

	Ratings
Set pressure	1.7 Yellow/2.2 bar Red
Contacts	Normally Open/Closed
Voltage	10 - 30 V
Max. current	1 A
Max. contact load	20VA
Protection	IP 65



Visual Indicator

Pressure gauge - 40mm diameter (0 - 6 bar) color coded to indicate bypass condition.

Weights (kg)

Model	Weight kg	Weight lb.
10DT	0.74	1.6
16DT	2.80	6.1
25DT	4.20	9.25

Filter Element

Disposable inorganic fibre media.

Available as 3, 6, 10, 16 and 25 absolute ($\beta_x \geq 75$)

10DT, 16DT, 25DT

Installation and Indicators

Installation

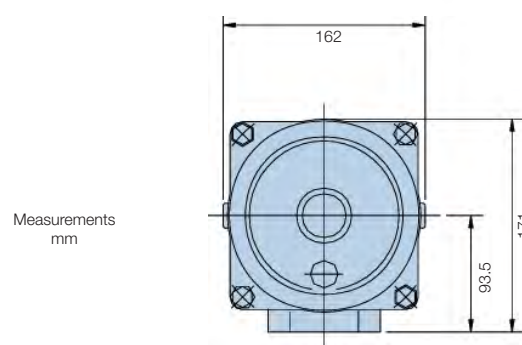
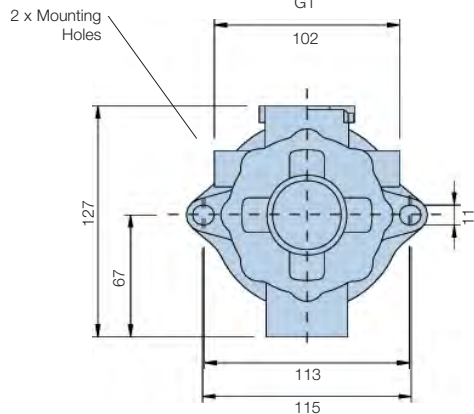
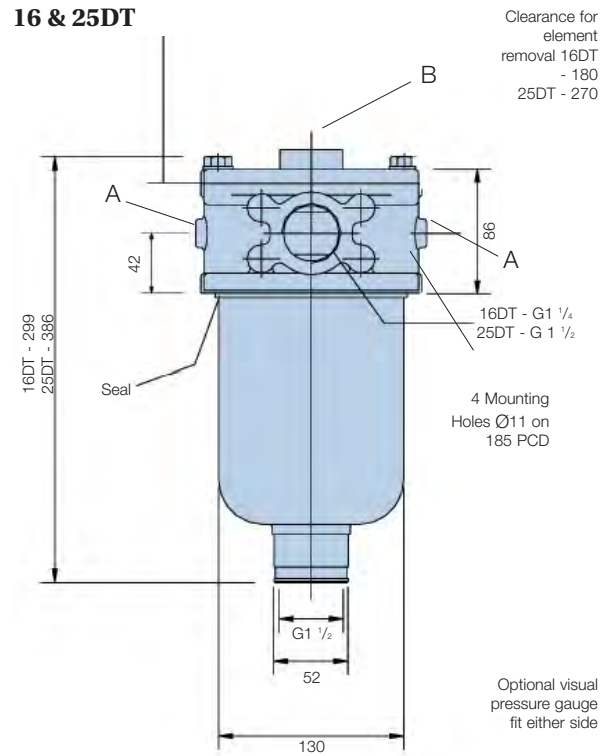
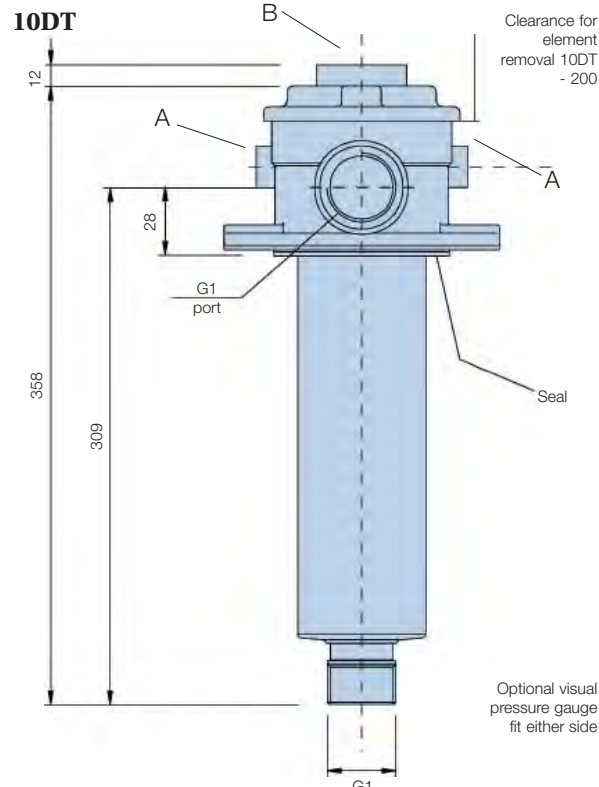

Measurements mm

Indicators

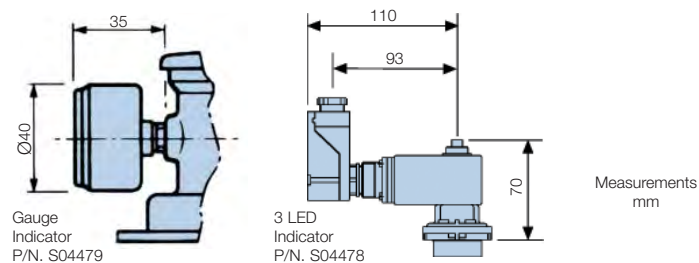

Optional Indicator Location

A	S04479	Visual
B	S04478	3 LED
A	940719	3 LED

10DT, 16DT, 25DT

Performance

To select the correct housing and element, it is recommended that the ratio between the bypass setting and the differential

pressure across the filter with a clean element, at the rated flow, should be at least 2:1.

Flow curves at 30cSt (140 SUS) viscosity show total pressure drop through housing and element.

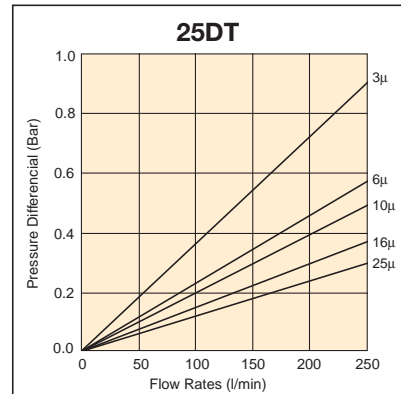
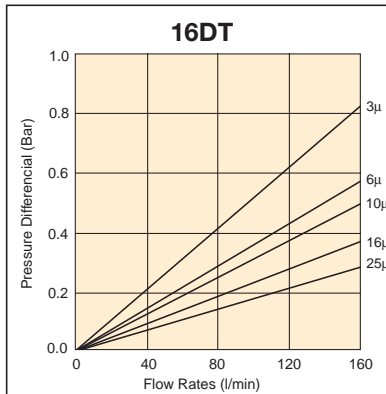
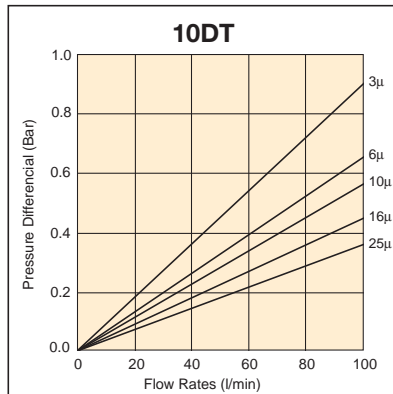

Installation & Element Servicing Instructions

Installation

The DT series Return Line filters are designed to operate in systems where the operating pressure does not exceed 10 bar. The filter should be mounted to the tank lid via 2 or 4 bolt fixings, with the bowl pointing vertically downwards.

Element Servicing

Stop and isolate the system and ensure that it has been de-pressurized. Remove the cover by un-screwing the cover on the 10DT or removing the 4 bolts on the cover of the 16DT and 25DT. Remove the filter bowl and element by pulling upwards.

Check the cover and bowl O rings and replace as required using a seal kit. Twist the element slightly to break the seal. Install the new element in the bowl and then refit the bowl into the housing. Re-install the cover.

Ordering Information

The following filter assemblies are supplied **WITH** bypass and indicator.

Standard products table

Part number	Flow (l/min)	Ports (BSP)	Media rating (μ)	Indication	Indicator rating	Bypass rating (bar)	Replacement elements
10DTA06EL50G16A	100	G1"	06	Electronic 4 LED	2.5 bar	3.5 bar	10DTEA05Q
10DTA10EL50G16A	100	G1"	10		2.5 bar	3.5 bar	10DTEA10Q
25DTA03EL50G24A	250	G1½"	03		2.5 bar	3.5 bar	25DTEA03Q
25DTA06EL50G24A	250	G1½"	06		2.5 bar	3.5 bar	25DTEA05Q
25DTA10EL50G24A	250	G1½"	10		2.5 bar	3.5 bar	25DTEA10Q

40RF, 50RF

High Flow Tank Mounted Filters

High Flow Tank Mounted Filters For Hydraulic Return Line Applications

The 40/50 RF series filters supplement the existing tank mounted range. They have been introduced to handle high flow applications incorporating Parker's customary housing strength and

element quality, and yet including optional features to enable the user to install in a wide variety of applications. This filter has also been designed to offer mounting and element interchangeability recommended by the DIN 24550 proposal.



Specification

Operating Temperature

-40°C to 120°C (-40°F to 250°F)

Construction

Housing - iron; cover - iron; bowl - steel

Inlet Ports

Model	Type
40RF-1	2" 3000-M Flange face
40RF-2	2 1/2" 3000-M Flange face
50RF-1	3" 3000-M Flange face

Bypass Settings

3.5 bar (50psi)

Indication

Visual pressure gauge 0-6 bar color code to indicate bypass condition or Electrical pressure switch. (Note: Above options mounted on either side of housing) Alternatively differential pressure visual pop-up indicator or Differential electrical pressure switch with pop-up visual indicator or 4 LED with 2 set points at 75% & 100%. Mounted to cover plate position only.

Weights

Model	kg (lb)
40RF-1	27 (59.5)
40RF-2	31 (68.3)
50RF-1	36 (79.4)

Fluid Compatibility

Suitable for use with mineral oils. For other fluids, please consult Parker Filtration.

Seals

Nitrile

Filter Element

Absolute 10, 20 micron microglass

Element Collapse Rating

10 bar (145psi)

40RF/50RF Housing Flow Curve

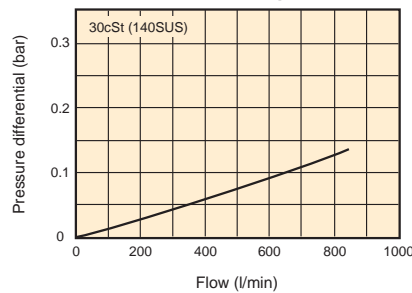

40RF Filter with 3Q Element

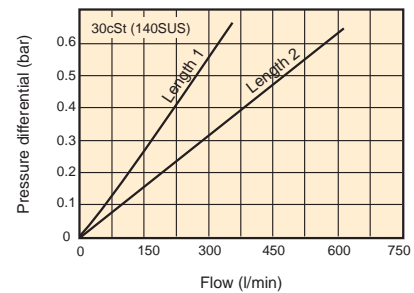

40RF Filter with 6Q Element

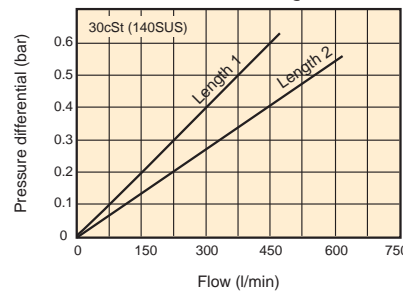

40RF/50RF 10Q Element

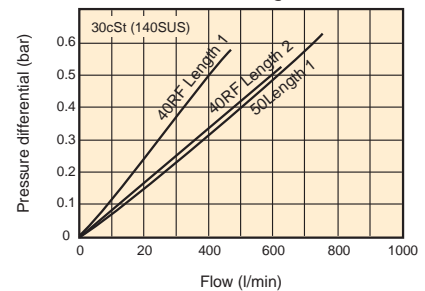

40RF/50RF 20Q Element

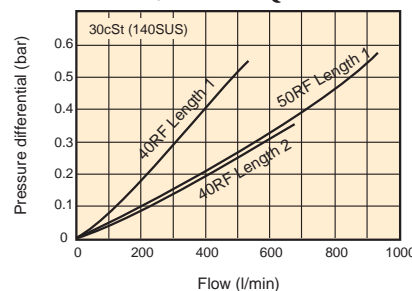

40RF, 50RF

Installation Details

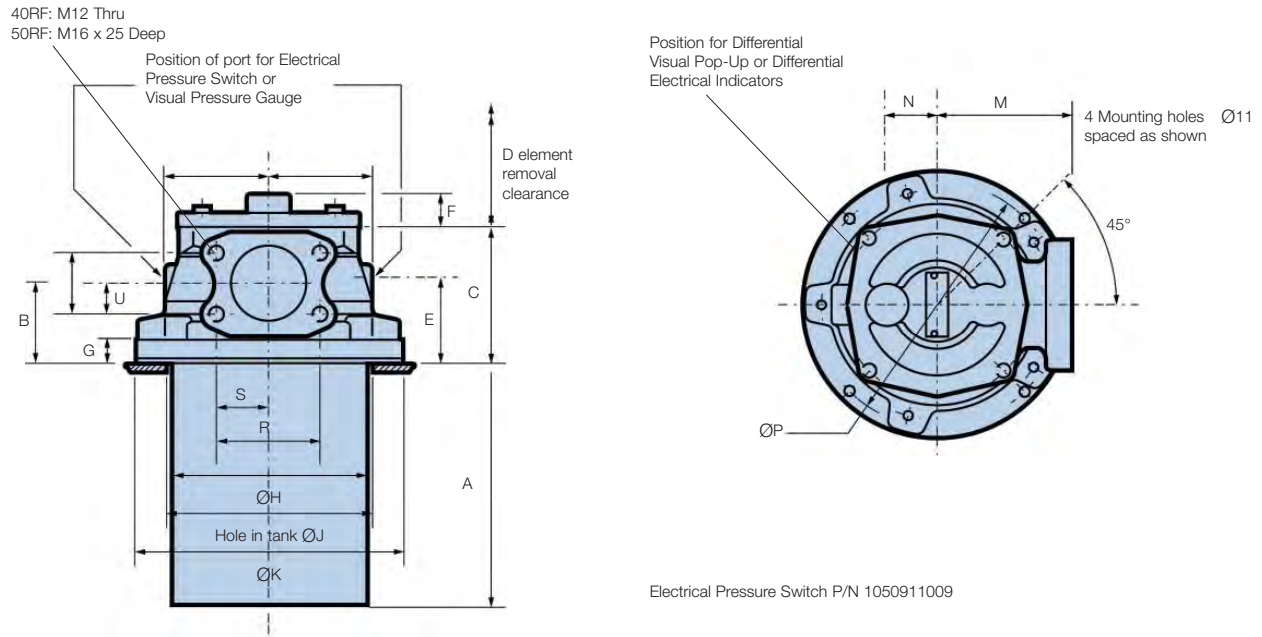

Dimensions (mm)

Model	A		B		C		D		E		F		G		H		J	
	mm	ins	mm	ins	mm	ins	mm	ins	mm	ins	mm	ins	mm	ins	mm	ins	mm	ins
40 RF-1	267	10.51	73	2.87	120	4.72	260	10.24	80	3.15	34	1.34	23	0.91	178	7.01	180	7.09
40 RF-2	417	16.42	73	2.87	120	4.72	410	16.14	80	3.15	34	1.34	23	0.91	178	7.01	180	7.09
50 RF-1	402	15.83	80	3.15	136	5.35	410	16.14	85	3.35	34	1.34	23	0.91	194	7.64	205	8.07
Model	K		L		M		N		P		R		S		T		U	
	mm	ins	mm	ins	mm	ins	mm	ins	mm	ins	mm	ins	mm	ins	mm	ins	mm	ins
40 RF-1	240	9.45	97	3.82	129	5.08	52	2.05	220	8.66	77.77	3.06	38.89	1.53	42.88	1.69	21.44	0.84
40 RF-2	240	9.45	97	3.82	129	5.08	52	2.05	220	8.66	88.9	3.50	44.45	1.75	50.8	2.00	25.40	1.00
50 RF-1	270	10.63	104	4.09	138	5.43	52	2.05	250	9.84	106.4	4.19	53.19	2.09	61.93	2.44	30.96	1.22

Ordering Information

Standard products table

Part number	Flow (l/min)	Flow (g/min)	Ports (BSP)	Media rating (μ)	Indication	Indicator rating	Bypass rating	Replacement elements
40RF203QPPL50YG91	630	95	2 1/2"	03	4 LED	2.5 bar (36psi)	3.5 bar (50psi)	G04711Q
40RF206QPPL50YG91	630	95	-3000	06				G04712Q
40RF210QPPL50YG91	630	95	flange	10	Electronic			G04713Q

Note: Optional side-mounted indicator Part Number 940719

SAE Series

SAE High Pressure Filters



ENGINEERING YOUR SUCCESS.

HF15P Series

High Pressure Filters

Pressure Filters - 3000 psi (207 bar) Application

Mechanical Visual or Electrical Visual Indicator

Mounting Provisions

Pressure Ratings:

Maximum Allowable Operating Pressure (MAOP):

3000 psi (207 bar)

Rated Fatigue Pressure: 3000 psi (207 bar)

Design Safety Factor: 3:1

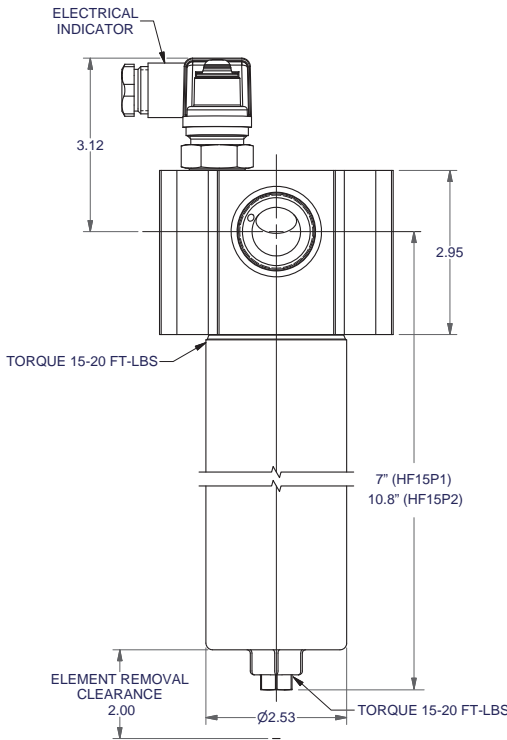
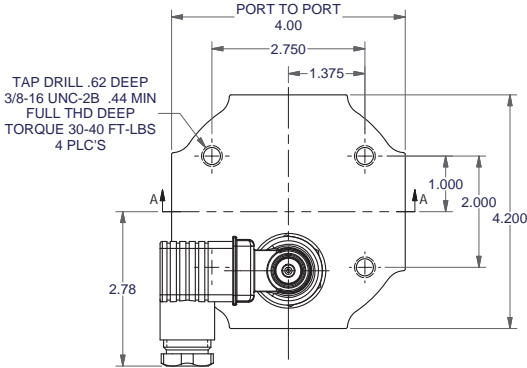

HF15P Series

Performance

HF15P-1 Element Performance

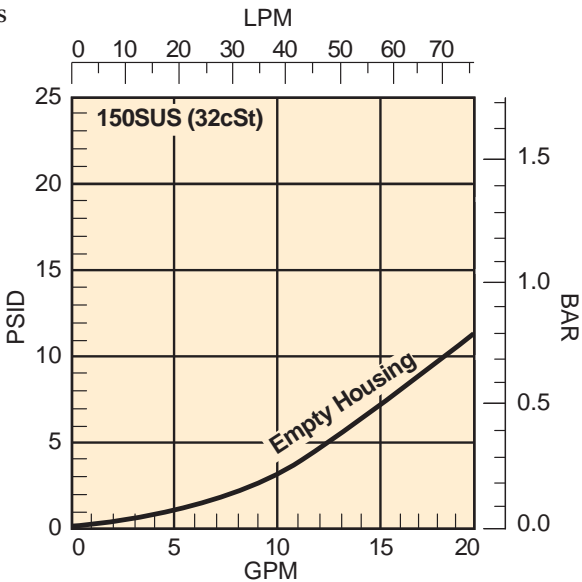
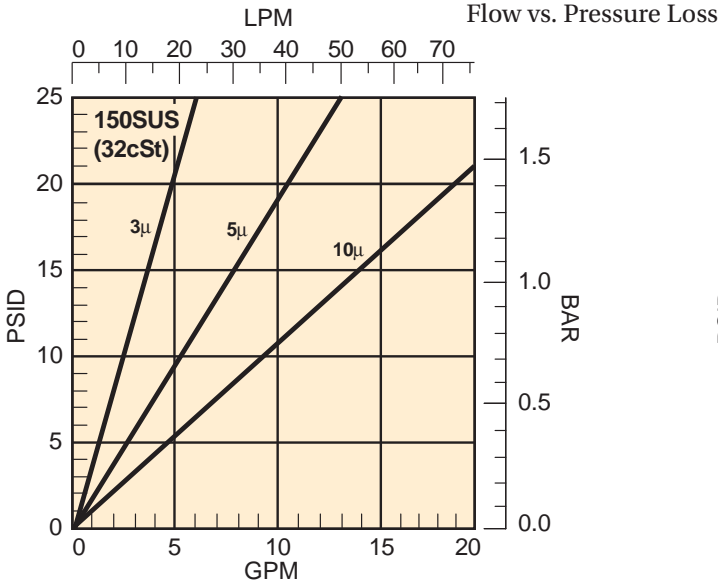

HF15P-2 Element Performance

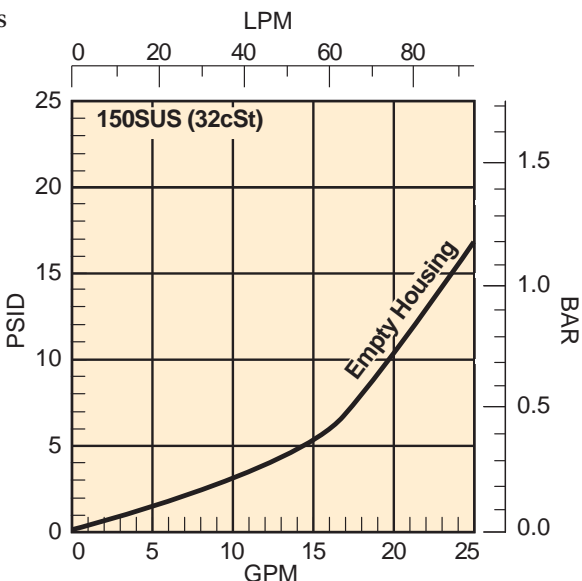
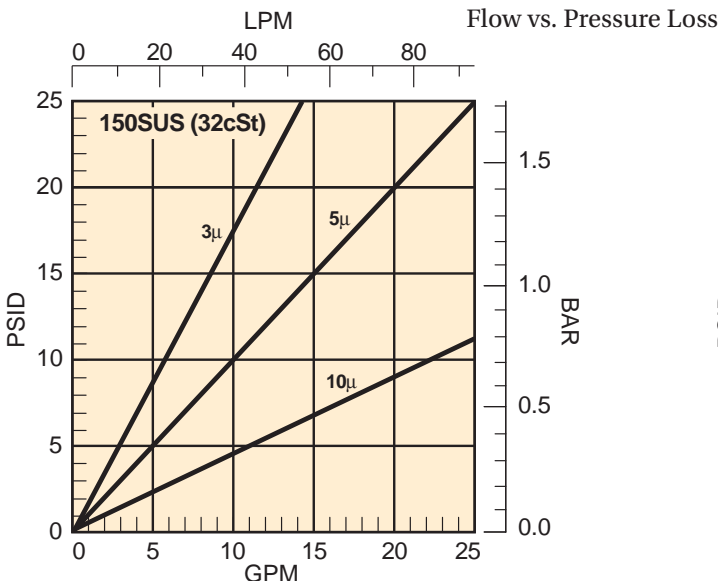

Assembly ΔP Formula

$$\Delta P_{\text{Assembly}} = \Delta P_{\text{Empty Housing}} + \Delta P_{\text{Element}} \times \frac{\text{New Viscosity}}{150} \times \frac{\text{New Specific Gravity}}{.90}$$

Note: For "H" High collapse elements use 1.4 x ΔP from curves above.

HF15P Series

How to Order

Select the desired symbol (in the correct position) to construct a model code.

Example:

BOX 1	BOX 2	BOX 3	BOX 4	BOX 5	BOX 6	BOX 7	BOX 8	BOX 9	BOX 10	BOX 11
		HF15P	1	L	3	M2	50	ST12	19	V

BOX 1: Division Code	
Symbol	Description
None	Leave Blank
Note: Used for specific automotive program identification.	

BOX 2: Plant Code	
Symbol	Description
None	Leave Blank
Note: Used for specific automotive plant location.	

BOX 3: Configuration	
Symbol	Description
HF15P	3,000 psi Filter

BOX 4: Housing Bowl Length	
Symbol	Description
1	1 Element, 4" Long
2	1 Element, 8" Long

BOX 5: Element Collapse Rating	
Symbol	Description
H	2000 psi (138 bar) (-21 option in Box 10 must be selected)
L	150 psi (10 bar) (-19 option in Box 10 must be selected)

BOX 6: Element Filtration Rating	
Symbol	Description
3	3 Micron Microglass
5	5 Micron Microglass
10	10 Micron Microglass
20	20 Micron Microglass

BOX 7: Indicator Type	
Symbol	Description
M2	Visual
E3B*	Electrical/Visual
E4MB*	Electrical/Visual
E4MC*	Electrical/Visual
E5B*	Electrical/Visual
E5MD*	Electrical/Visual
F4MS	Standard Dual output electrical indicator
F4MN	Device Net Dual output electronic indicator
*NOTE: Please refer to indicator drawings and chart on pages 53 and 54 for connector and wiring options.	

BOX 8: Indicator Setting	
Symbol	Description
50	50 psid (3.5 bar)
125	125 psid (8.6 bar) F4MS/F4MN indicator with option -21 only.

BOX 9: Port Size	
Symbol	Description
ST12	3/4-16 UN-2B (ISO 11926)
M27	M27 x 2 (ISO 6149)
G12	G 3/4-14 BSPP (ISO 1179-1)
SMP	SAE Manifold Mount
MMP	Metric Manifold Mount
GMP	BSPP Manifold Mount

BOX 10: Options	
Symbol	Description
19	Drain Port on Bowl
21	Non-Bypass with Drain

BOX 11: Seal Compound	
Symbol	Description
V	Fluorocarbon

Replacement Elements

Media	Element Collapse Rating	Single Length (Fluorocarbon)	Double Length (Fluorocarbon)
3 Micron	150 psi (10 bar)	HF21L3VQ	HF22L3VQ
3 Micron	2000 psi (138 bar)	HF21H3VQ	HF22H3VQ
5 Micron	150 psi (10 bar)	HF21L5VQ	HF22L5VQ
5 Micron	2000 psi (138 bar)	HF21H5VQ	HF22H5VQ
10 Micron	150 psi (10 bar)	HF21L10VQ	HF22L10VQ
10 Micron	2000 psi (138 bar)	HF21H10VQ	HF22H10VQ
20 Micron	150 psi (10 bar)	HF21L20VQ	HF22L20VQ
20 Micron	2000 psi (138 bar)	HF21H20VQ	HF22H20VQ

HF3 Series

High Pressure Filters

HF3 Pressure Filter - 2500 psi (172 bar) Application

Non-Bypass Design

Upstream and Downstream Test Ports

Allows user to do maintenance troubleshooting.

Electrical Visual Indicator

For electrical indicator options and factory pin wiring, see pages 53-54 (types E and F4M electrical indicators).

Drain Port

Elements

3, 5, and 10 micron HF3 elements with $\beta \geq 200$ with dual stage filtering media for up to 40% increased dirt holding capacity.

Mounting Provisions

Pressure Ratings:

Maximum Allowable Operating Pressure (MAOP): 2500 psi (172 bar)

Rated Fatigue Pressure: 2500 psi (172 bar)

Flow Rate Curves

- Select flow rate.
- Determine micron selection.
- For maximum filter life, ΔP should not exceed 1/3 bypass/indicator setting.

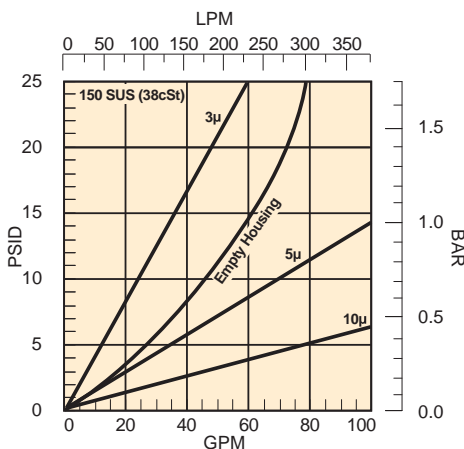

Assembly ΔP Formula						
ΔP Assembly	=	ΔP from curve	x	$\frac{\text{New Viscosity}}{300}$	x	$\frac{\text{New Specific Gravity}}{.90}$

Note: For "H" High collapse elements use 1.4 x ΔP from curves above.

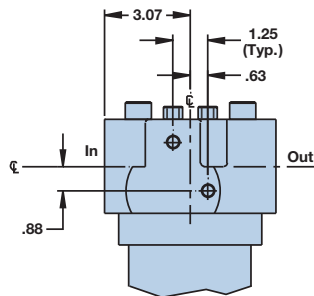

Right Hand

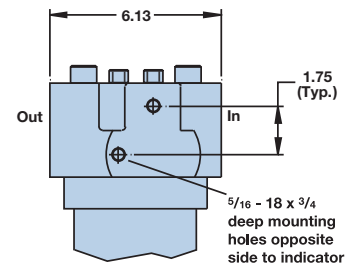

Left Hand

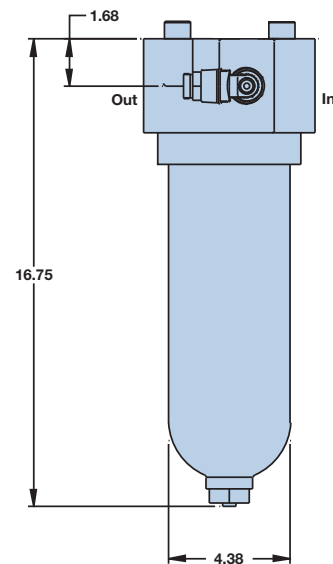

HF3 Series

How to Order

Select the desired symbol (in the correct position) to construct a model code.

Example:

BOX 1	BOX 2	BOX 3	BOX 4	BOX 5	BOX 6	BOX 7	BOX 8	BOX 9	BOX 10	BOX 11	BOX 12	BOX 13
		HF	3	1	P3	H	3	M2	50	ST16	11	V

BOX 1: Division Code	
Symbol	Description
None	Leave Blank
Note: Used for specific automotive program identification.	

BOX 2: Plant Code	
Symbol	Description
None	Leave Blank
Note: Used for specific automotive plant location.	

BOX 3: Configuration	
Symbol	Description
HF	Hydraulic Filter

BOX 4: Element Diameter	
Symbol	Description
3	3 inch (NOMINAL)

BOX 5: Housing Bowl Length	
Symbol	Description
1	1 Element, 8" Long

BOX 6: Housing Pressure Type	
Symbol	Description
P3	Pressure Type

BOX 7: Element Collapse Rating	
Symbol	Description
H	2000 PSI (-11 option, Box 12)

BOX 8: Element Filtration Rating	
Symbol	Description
3	3 Micron Microglass
5	5 Micron Microglass
10	10 Micron Microglass
*Consult factory for other requirements.	

BOX 9: Indicator Type	
Symbol	Description
M2	Visual
E3B*	Electrical/Visual
E4MB*	Electrical/Visual
E4MC*	Electrical/Visual
E5B*	Electrical/Visual
E5MD*	Electrical/Visual
F4MS	Standard Dual output electrical indicator
F4MN	Device Net Dual output electronic indicator

*NOTE: Please refer to indicator drawings and chart on pages 53 and 54 for connector and wiring options. Located at left side of inlet — for right side, add "R" to symbol. Example: E3BR.

BOX 10: Indicator Setting	
Symbol	Description
50	50 psid (3.5 bar)
125	125 psid (8.6 bar) F4M indicator

BOX 11: Port Size	
Symbol	Description
ST16	1 5/16-12 UN-2B (ISO 11926)
M33	M33 x 2 (ISO 6149)
G16	1-11 BSPP (ISO 1179G228)

BOX 12: Options	
Symbol	Description
11	Non-Bypass

BOX 13: Seal Compound	
Symbol	Description
V	Fluorocarbon

Replacement Elements

Media	Element Collapse Rating	Single Length (Fluorocarbon)
3 Micron	2000 psi (138 bar)	HF31H3VQ
5 Micron	2000 psi (138 bar)	HF31H5VQ
10 Micron	2000 psi (138 bar)	HF31H10VQ

HF3 Duplex

High Pressure Filter

30PDHF3 Duplex Pressure Filter - 3000 psi (207 bar) Application

The Parker 30PDHF3 duplex pressure filter provides uninterrupted filtration for equipment that cannot be shut down for servicing.

The 30PDHF3 allows you to simply switch the diverter valve and service the element while the other side is in service.

A pressure balancing valve and downstream check valves are all neatly assembled in a compact manifold head that makes operation safe, smooth and easy.

Vent valves are also included to insure all air is purged after the off-duty element is serviced so that maximum system performance is achieved.

The Parker 30PDHF3 makes use of industry proven components. Elements are multi-pass tested in accordance with ISO4572/ISO16889. Bowls and head are subjected to rigorous fatigue testing to insure a trouble free service life.

Installation Dimensions

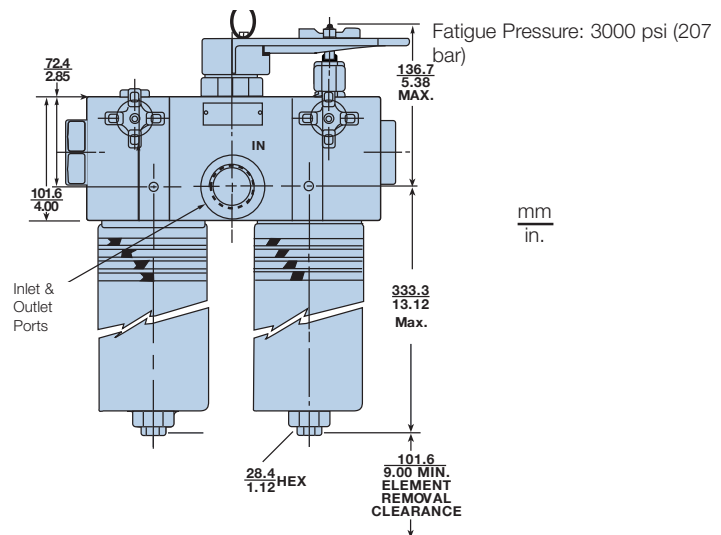
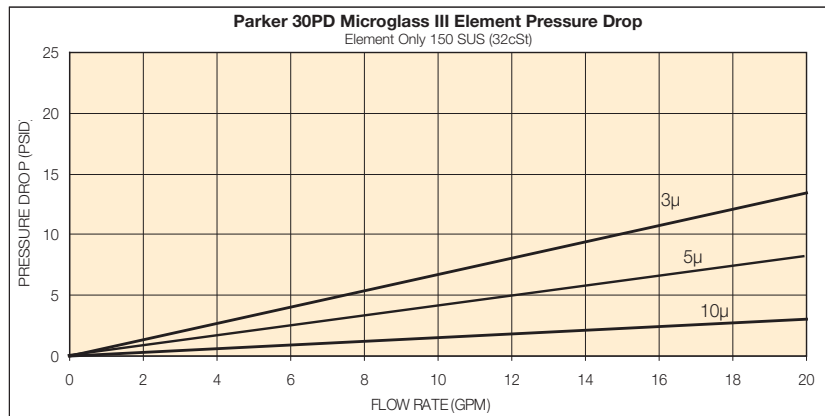
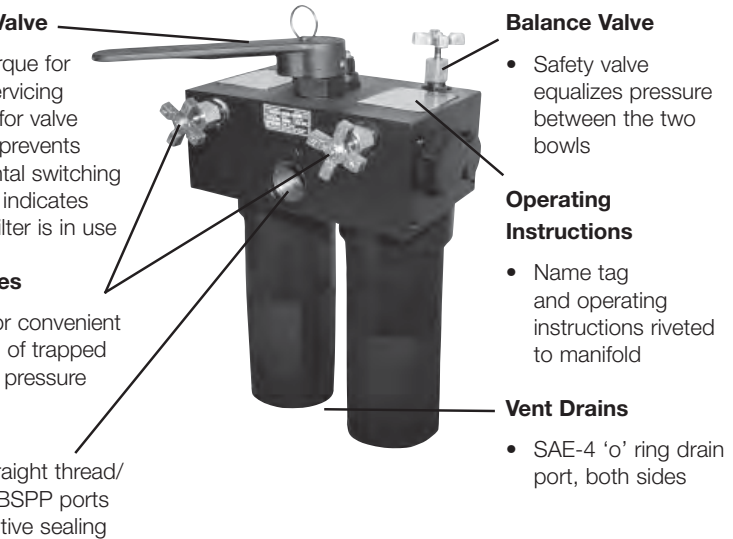
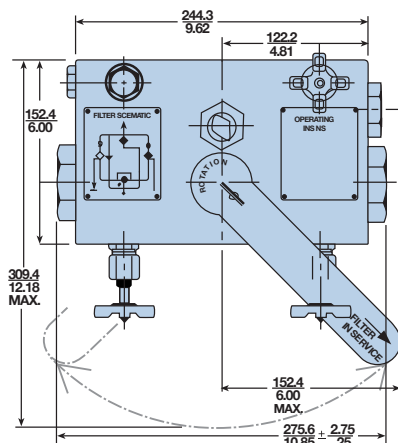

HF3 Duplex Series

How to Order

Select the desired symbol (in the correct position) to construct a model code.

Example:

BOX 1	BOX 2	BOX 3	BOX 4	BOX 5	BOX 6	BOX 7	BOX 8	BOX 9	BOX 10	BOX 11
		30PDHF3	2	L	10	E5MD	50	ST16	19	V

BOX 1: Division Code	
Symbol	Description
None	Leave Blank
Note: Used for specific automotive program identification.	

BOX 2: Plant Code	
Symbol	Description
None	Leave Blank
Note: Used for specific automotive plant location.	

BOX 3: Configuration	
Symbol	Description
30PDHF3	Hydraulic Filter, duplex

BOX 4: Housing Bowl Length	
Symbol	Description
2	1 Element, 8" Long

BOX 5: Element Collapse Rating	
Symbol	Description
H	2000 PSI (-21 option in Box 10 must be selected)
L	150 PSI (-19 option in Box 10 must be selected)

BOX 6: Element Filtration Rating	
Symbol	Description
3	3 Micron Microglass
5	5 Micron Microglass
10	10 Micron Microglass
*Consult factory for other requirements.	

BOX 7: Indicator Type	
Symbol	Description
M2	Visual
E3B*	Electrical/Visual
E4MB*	Electrical/Visual
E4MC*	Electrical/Visual
E5B*	Electrical/Visual
E5MD*	Electrical/Visual
F4MS	Standard Dual output electrical indicator
F4MN	Device Net Dual output electronic indicator
*NOTE: Please refer to indicator drawings and chart on pages 53 and 54 for connector and wiring options.	

BOX 8: Indicator Setting	
Symbol	Description
50	50 psid (3.5 bar)
125	125 psid (8.6 bar) F4M indicator with Option -21 only.

BOX 9: Port Size	
Symbol	Description
ST16	1 5/16-12 UN-2B (ISO 11926)
M33	M33 x 2 (ISO 6149)
G16	1-11 BSPP (ISO 1179G228)

BOX 10: Options	
Symbol	Description
19	SAE-5 drain port on bowl
21	No bypass and drain

BOX 11: Seal Compound	
Symbol	Description
V	Fluorocarbon

Replacement Elements

Media	Element Collapse Rating	Single Length (Fluorocarbon)
3 Micron	150 psi (10 bar)	HF31L3VQ
3 Micron	2000 psi (138 bar)	HF31H3VQ
5 Micron	150 psi (10 bar)	HF31L5VQ
5 Micron	2000 psi (138 bar)	HF31H5VQ
10 Micron	150 psi (10 bar)	HF31L10VQ
10 Micron	2000 psi (138 bar)	HF31H10VQ

HF4 Series

High Pressure Filter

50P4 Pressure Filter - 3500 psi (241 bar) Applications

Air Bleed Port

Guarantees total use of element dirt holding capacity.

Mechanical Visual or Electrical Visual Indicator

For electrical indicator options and factory pin wiring, see pages 53-54 (type D electrical indicator).

Elements

3, 5 and 10 micron HF4 elements with $\beta \geq 200$ with dual stage filtering media for up to 40% increased dirt holding capacity.

Pressure Ratings:

Maximum Allowable Operating Pressure (MAOP): 3500 psi (241 bar)

Rated Fatigue Pressure: 3500 psi (241 bar)

Design Safety Factor: 3:1



50P4-2

Linear Measure: millimeter
inch

Length	50P4-1	50P4-2
X	254.0	508.0
	10.00	20.00
Z	387.1	622.8
	15.24	24.52

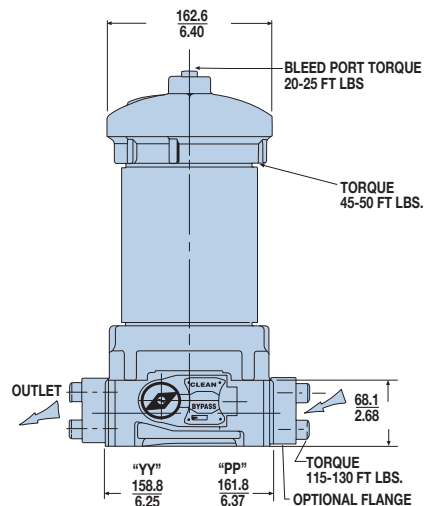
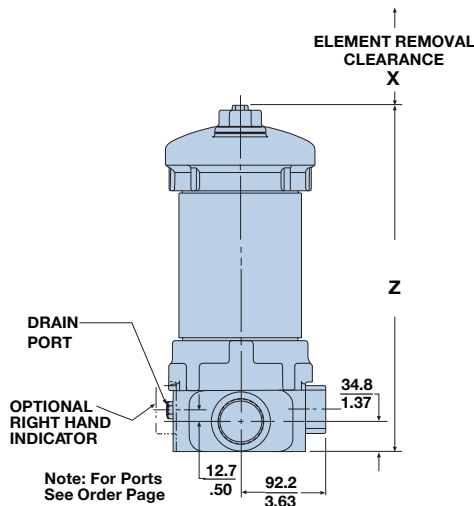
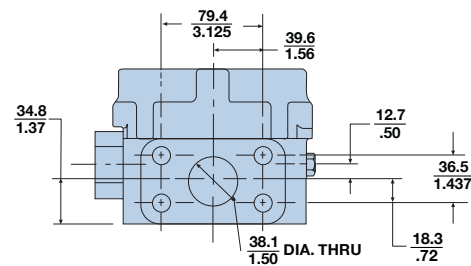
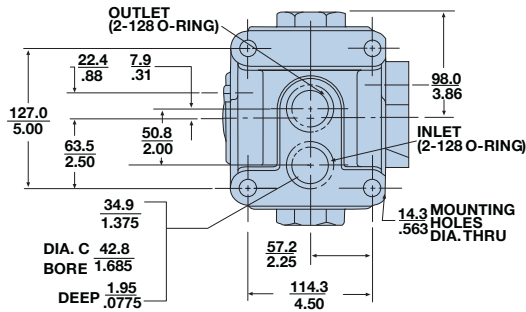

HF4 Series

Performance

50P4-1 Element Performance

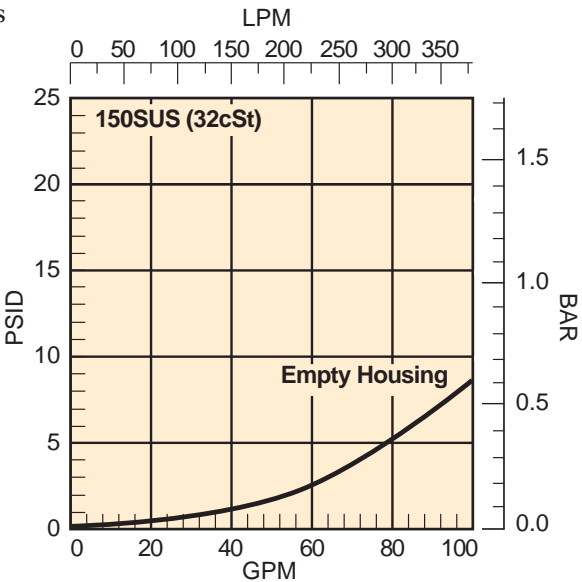
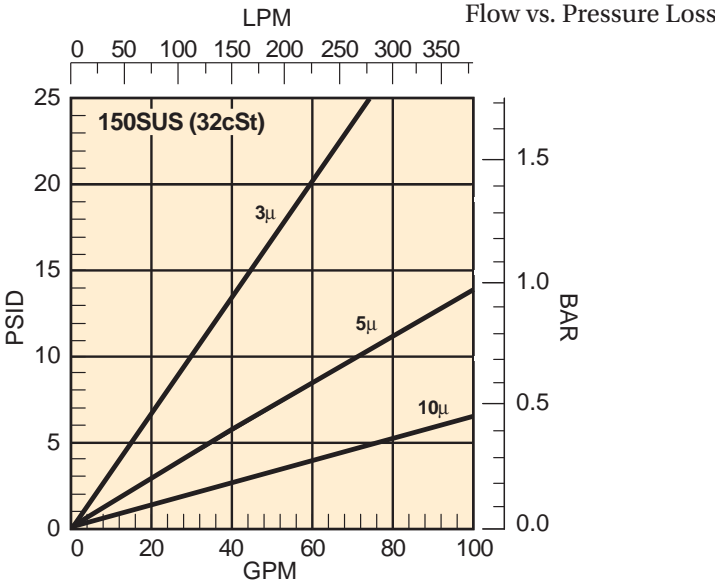

50P4-2 Element Performance

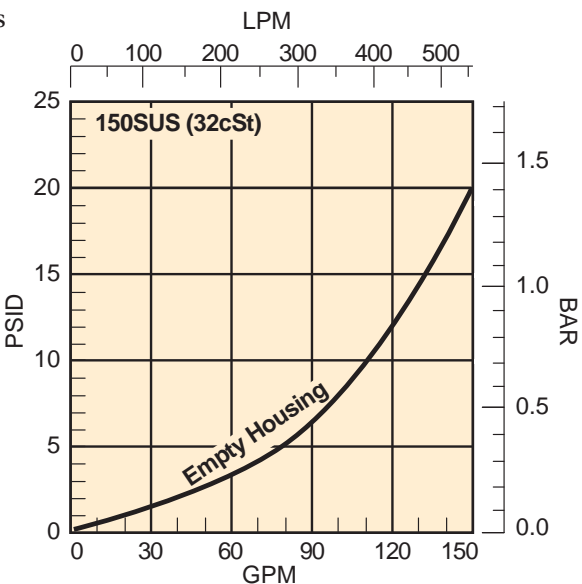
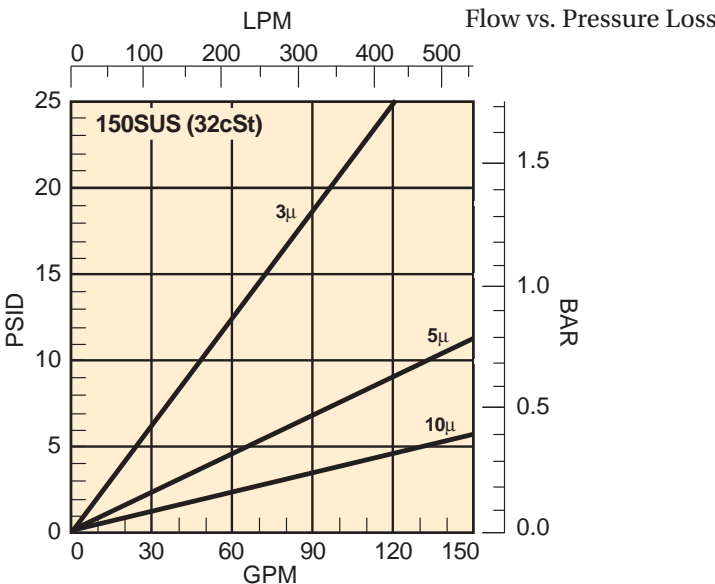

Assembly ΔP Formula

$$\Delta P_{\text{Assembly}} = \Delta P_{\text{Empty Housing}} + \Delta P_{\text{Element}} \times \frac{\text{New Viscosity}}{150} \times \frac{\text{New Specific Gravity}}{.90}$$

Note: For "H" High collapse elements use 1.4 x ΔP from curves above.

HF4 Series

How to Order

Select the desired symbol (in the correct position) to construct a model code.

Example:

BOX 1	BOX 2	BOX 3	BOX 4	BOX 5	BOX 6	BOX 7	BOX 8	BOX 9	BOX 10	BOX 11
		50P4	1	H	10	E4MB	50	FM	11	V

BOX 1: Division Code	
Symbol	Description
None	Leave Blank
Note: Used for specific automotive program identification.	

BOX 2: Plant Code	
Symbol	Description
None	Leave Blank
Note: Used for specific automotive plant location.	

BOX 3: Configuration	
Symbol	Description
50P4	Hydraulic Pressure Filter

BOX 4: Housing Bowl Length	
Symbol	Description
1	1 Element
2	2 Elements

BOX 5: Element Collapse Rating	
Symbol	Description
H	2000 PSI (138 bar) (-11 option in Box 10 must be selected)
L	150 PSI (10 bar) (-1 option in Box 10 must be selected)

BOX 6: Element Filtration Rating	
Symbol	Description
3	3 Micron Microglass
5	5 Micron Microglass
10	10 Micron Microglass
*Consult factory for other requirements.	

BOX 7: Indicator Type	
Symbol	Description
IR	Visual, Right Side
IL	Visual, Left Side
E3B*	Electrical/Visual
E4MB*	Electrical/Visual
E4MC*	Electrical/Visual
E5B*	Electrical/Visual
E5MD*	Electrical/Visual
F4MS	Standard Dual output electrical indicator
F4MN	Device Net Dual output electronic indicator

*NOTE: Please refer to indicator drawings and chart on pages 53 and 54 for connector and wiring options. Located at left side of inlet — for right side, add "R" to symbol. Example: E3BR.

BOX 8: Indicator Setting	
Symbol	Description
50	50 psid (3.5 bar)

BOX 9: Port Size	
Symbol	Description
ST24	1 7/8-12 UN-2B (ISO 11926)
M48	M48 x 2 (ISO 6149)
G24	1 1/2-11 BSPP (ISO 1179G228)
SMP	SAE Manifold Mount
MMP	Metric Manifold Mount
GMP	BSPP Manifold Mount
FS	1 1/2" Flange (ISO 6162) 5/8"-11 bolt holes x 1.03 in. deep
FM	1 1/2" Flange (ISO 6162) M16 x 2 bolt holes, 25.5 mm deep

BOX 10: Bypass Options	
Symbol	Description
1	50 psi (3.5 bar) bypass (-L option in Box 5 must be selected)
11	Non bypass (-H option in Box 5 must be selected)

BOX 11: Seal Compound	
Symbol	Description
V	Fluorocarbon

Replacement Elements

Media	Element Collapse Rating	Single Length (Fluorocarbon)	Double Length (Fluorocarbon)
3 Micron	150 psi (10 bar)	HF41L3VQ	HF42L3VQ
3 Micron	2000 psi (138 bar)	HF41H3VQ	HF42H3VQ
5 Micron	150 psi (10 bar)	HF41L5VQ	HF42L5VQ
5 Micron	2000 psi (138 bar)	HF41H5VQ	HF42H5VQ
10 Micron	150 psi (10 bar)	HF41L10VQ	HF42L10VQ
10 Micron	2000 psi (138 bar)	HF41H10VQ	HF42H10VQ

HF4 Duplex

Medium and High Pressure Filters

MPD/MPDH/Duplex Pressure Filter - MPD - Dual 1500 psi (103 bar), MPDH - Dual 3000 psi (207 bar)

- True duplex design with full neutral center valve
- SAE porting
- Flows to 110 gpm (416 l/min)
- Modular design with double- or triple-length side chamber extensions
- Internal equalization
- HF4 elements as standard
- Non Bypass Option

Pressure Ratings:

Maximum Allowable Operating Pressure (MAOP):

MPD - 1500 psi (103 bar)

MPDH - 3000 psi (207 bar)

Rated Fatigue Pressure:

MPD - 1500 psi (103 bar)

MPDH - 3000 psi (207 bar)

Design Safety Factor: 3:1



HF4 Elements



HF4 Duplex

Performance

MPD/MPDH-1 Element Performance

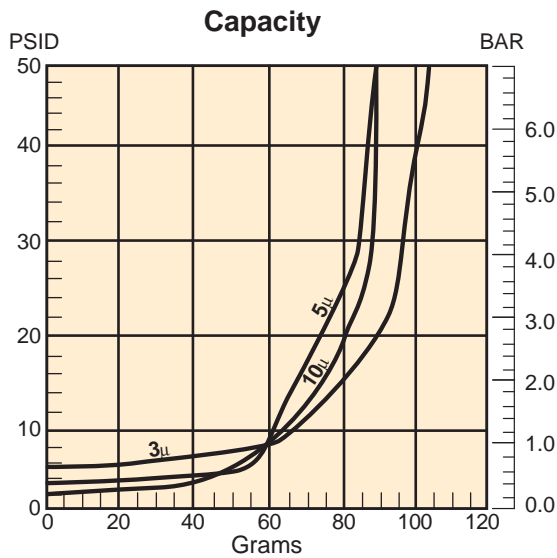

Flow vs. Pressure Loss

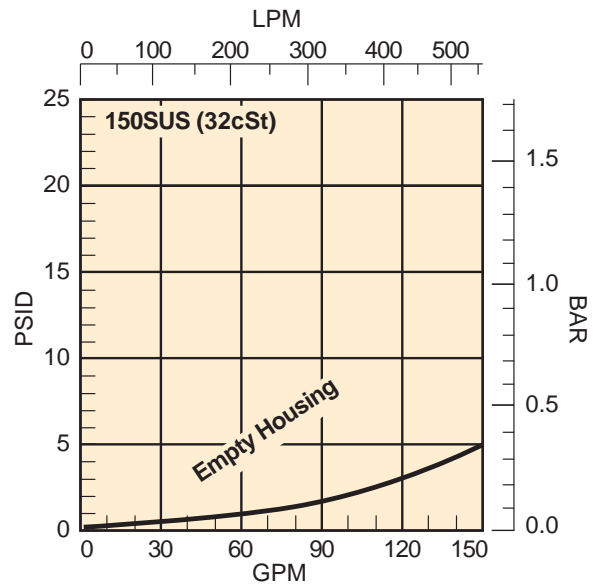
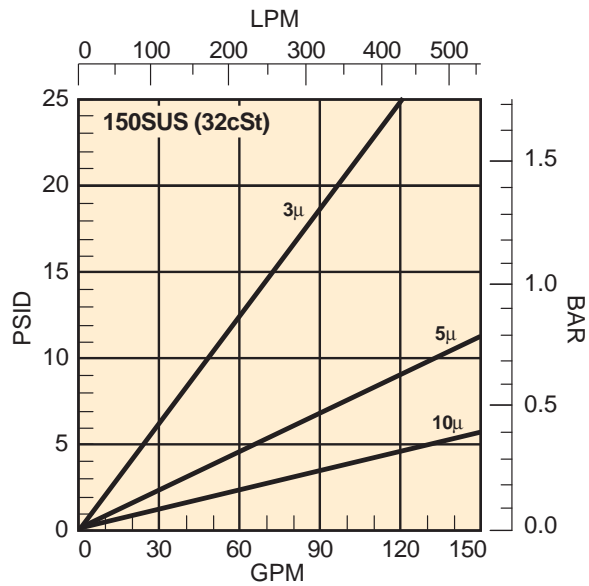

Assembly ΔP Formula

$$\Delta P_{\text{Assembly}} = \Delta P_{\text{Empty Housing}} + \Delta P_{\text{Element}} \times \frac{\text{New Viscosity}}{150} \times \frac{\text{New Specific Gravity}}{.90}$$

Note: For "H" High collapse elements use 1.4 x ΔP from curves above.

HF4 Duplex

Performance

MPD/MPDH-2 Element Performance

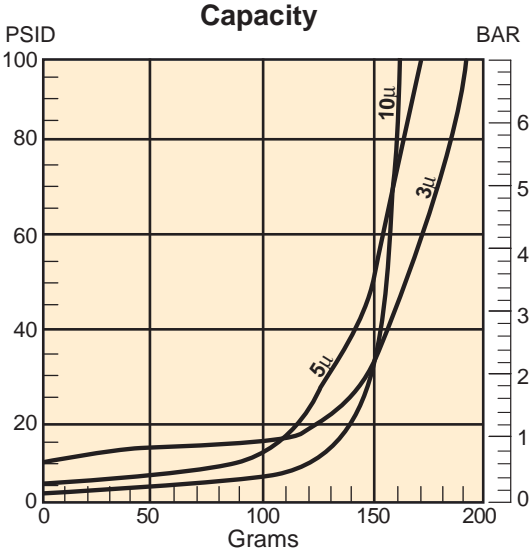

Flow vs. Pressure Loss

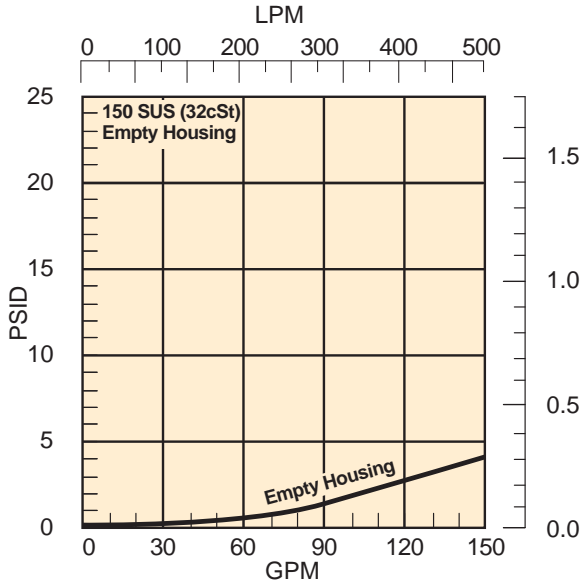
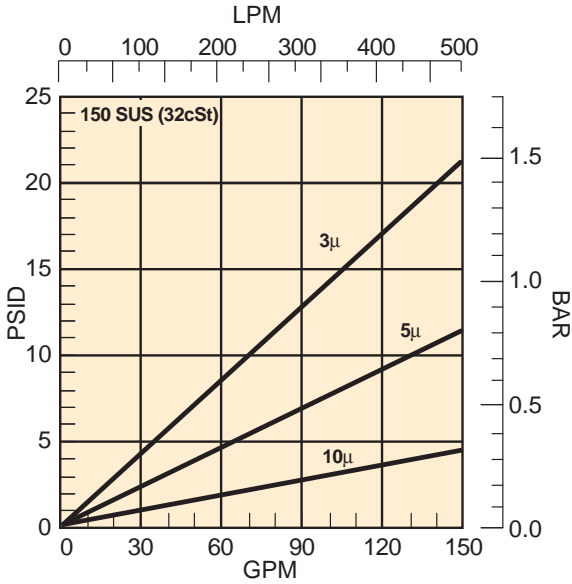

Assembly ΔP Formula

$$\Delta P_{\text{Assembly}} = \Delta P_{\text{Empty Housing}} + \Delta P_{\text{Element}} \times \frac{\text{New Viscosity}}{150} \times \frac{\text{New Specific Gravity}}{.90}$$

Note: For "H" High collapse elements use 1.4 x ΔP from curves above.

HF4 Duplex Series

How to Order

Select the desired symbol (in the correct position) to construct a model code.

Example:

BOX 1	BOX 2	BOX 3	BOX 4	BOX 5	BOX 6	BOX 7	BOX 8	BOX 9	BOX 10	BOX 11	
		MPD	1	L		10Q	E5MD	25	FS	1	V

BOX 1: Division Code	
Symbol	Description
None	Leave Blank

Note: Used for specific automotive program identification.

BOX 2: Plant Code	
Symbol	Description
None	Leave Blank

Note: Used for specific automotive plant location.

BOX 3: Configuration	
Symbol	Description
MPD	Duplex Filter
MPDH	Duplex Filter, High Pressure

BOX 4: Housing Bowl Length	
Symbol	Description
1	Single
2	Double
3	Triple

BOX 5: Element Collapse Rating	
Symbol	Description
L	150 PSI (10 bar) (-1 option in Box 11 must be selected)
H	2000 PSI (138 bar) (-21 option in Box 11 must be selected)

BOX 6: Core	
Symbol	Description
None	Permanent Core

BOX 7: Element Filtration Rating	
Symbol	Description
3	3 Micron Microglass
5	5 Micron Microglass
10	10 Micron Microglass

BOX 8: Indicator Type	
Symbol	Description
M2	Visual/Auto Reset
E2	Electrical (DIN 43650 Hirschman style)
E3B*	Electrical/Visual
E4MB*	Electrical/Visual
E4MC*	Electrical/Visual
E5B*	Electrical/Visual
E5MD*	Electrical/Visual
P	Indicator Port Plugged
F4MS	Standard Dual output electrical indicator with non bypass only
F4MN	Device Net Dual output electronic indicator with non bypass only

*NOTE: Please refer to indicator drawings and chart on pages 53 and 54 for connector and wiring options.

BOX 9: Indicator Setting	
Symbol	Description
25	25 psi (1.7 bar)
50	50 psi (3.5 bar) If "no bypass" option (-21) and an indicator is selected, above symbols (25, 50) denote indicator setting
125	125 psid (8.6 bar) *F4M indicator only (-21 option in Box 11 must be selected)

BOX 10: Port Size	
Symbol	Description
ST24	1 7/8-12 UN-2B (ISO 11926)
M48	M48 x 2 (ISO 6149)
G24	1 1/2-11 BSPP (ISO 1179G228)
SMP	SAE Manifold Mount
MMP	Metric Manifold Mount
GMP	BSPP Manifold Mount
FS	1 1/2" Flange (ISO 6162) 5/8"-11 bolt holes x 1.03 in. deep
FM	1 1/2" Flange (ISO 6162) M16 x 2 bolt holes, 25.5 mm deep

BOX 11: Bypass Options	
Symbol	Description
1	None
11	No bypass

BOX 12: Seal Compound	
Symbol	Description
V	Fluorocarbon

Replacement Elements

Media	Element Collapse Rating	Single Length (Fluorocarbon)	Double Length (Fluorocarbon)
3 Micron	150 psi (10 bar)	HF41L3VQ	HF42L3VQ
3 Micron	2000 psi (138 bar)	HF41H3VQ	HF42H3VQ
5 Micron	150 psi (10 bar)	HF41L5VQ	HF42L5VQ
5 Micron	2000 psi (138 bar)	HF41H5VQ	HF42H5VQ
10 Micron	150 psi (10 bar)	HF41L10VQ	HF42L10VQ
10 Micron	2000 psi (138 bar)	HF41H10VQ	HF42H10VQ



SAE Series

Return Filters



ENGINEERING YOUR SUCCESS.

15CN Return Filter

HF2 Series Filters
Low Pressure

15CN Return Filters - 800 psi (55 bar) Applications

Mechanical Visual or Electrical Visual Indicator

For electrical indicator options and factory pin wiring, see pages 53-54 (types E and F4M electrical indicators).

Element

HF2 4" and 8" Long, 3, 5, and 10 micron element with $\beta \geq 200$ and dual stage filtering media for up to 40% increased dirt holding capacity.



Mounting Provisions

Reverse Check Option

For system decompression, includes Element Check to prevent back flow during system decompression.

Pressure Ratings:

Maximum Allowable Operating Pressure (MAOP): 800 psi (55 bar)

Rated Fatigue Pressure: 800 psi (55 bar)

Design Safety Factor: 2.5:1

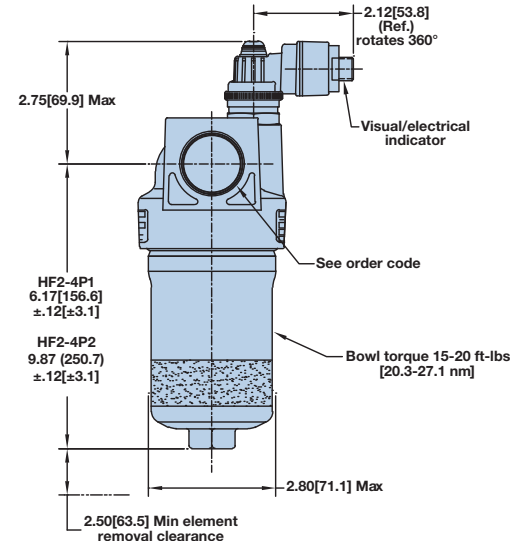
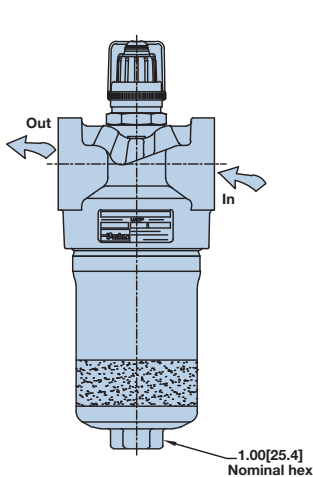
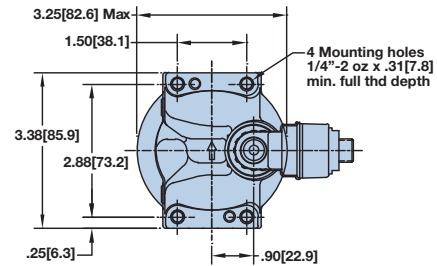
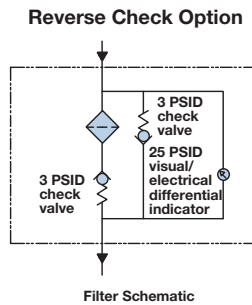

15CN Return Filter

Performance

15CN-1 Element Performance

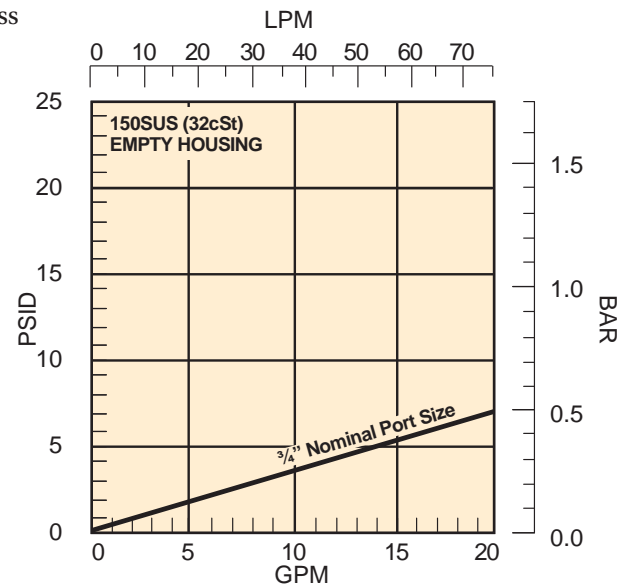
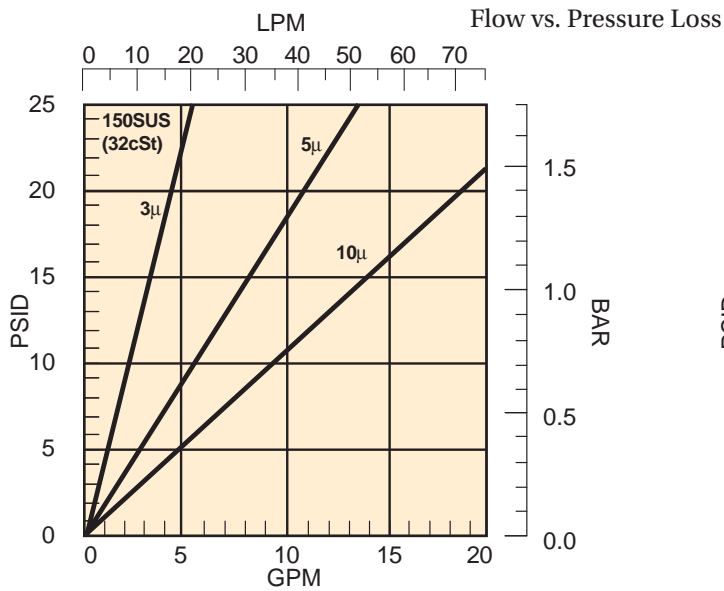

15CN-2 Element Performance

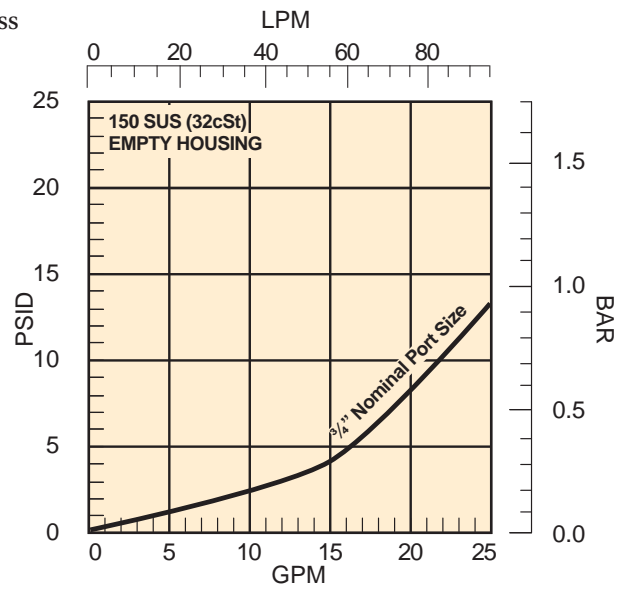
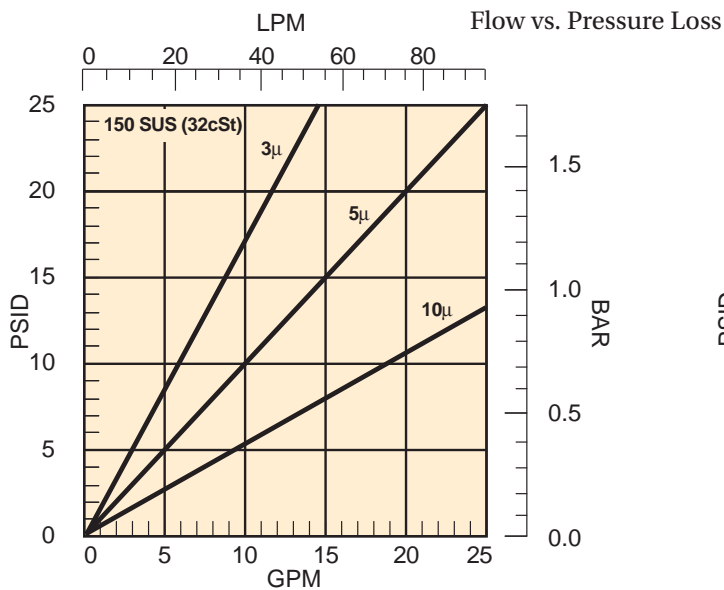

Assembly ΔP Formula

$$\Delta P_{\text{Assembly}} = \Delta P_{\text{Empty Housing+Element}} \times \frac{\text{New Viscosity}}{150} \times \frac{\text{New Specific Gravity}}{.90}$$

Note: For "H" High collapse elements use 1.4 x ΔP from curves above.

15CN Return Filter: HF2 Series

How to Order

Select the desired symbol (in the correct position) to construct a model code.

Example:

BOX 1	BOX 2	BOX 3	BOX 4	BOX 5	BOX 6	BOX 7	BOX 8	BOX 9	BOX 10	BOX 11
		15CN	2	L	10	E5B	25	ST12	19	V

BOX 1: Division Code	
Symbol	Description
None	Leave Blank
Note: Used for specific automotive program identification.	

BOX 2: Plant Code	
Symbol	Description
None	Leave Blank
Note: Used for specific automotive plant location.	

BOX 3: Configuration	
Symbol	Description
15CN	Hydraulic Filter HF2

BOX 4: Housing Bowl Length	
Symbol	Description
1	1 Element, 4" Long
2	1 Element, 8" Long

BOX 5: Element Collapse Rating	
Symbol	Description
H	2000 PSI (138 bar) (-21 or -R5 option in Box 10 must be selected)
L	150 PSI (10 bar) (-19 option in Box 10 must be selected)

BOX 6: Element Filtration Rating	
Symbol	Description
3	3 Micron Microglass
5	5 Micron Microglass
10	10 Micron Microglass
*Consult factory for other requirements.	

BOX 7: Indicator Type	
Symbol	Description
M2	Visual, Top
E3B*	Electrical/Visual
E4MB*	Electrical/Visual
E4MC*	Electrical/Visual
E5B*	Electrical/Visual
E5MD*	Electrical/Visual
F4MS	Standard Dual output electrical indicator
F4MN	Device Net Dual output electronic indicator
*NOTE: Please refer to indicator drawings and chart on pages 53 and 54 for connector and wiring options.	

BOX 8: Indicator Setting	
Symbol	Description
25	25 psid (1.7 bar)
50	50 psid (3.5 bar)
125	125 psid (8.6 bar) F4M indicator with option -21 or -R5.

BOX 9: Port Size	
Symbol	Description
ST12	1 1/16-12 UN-2B (ISO 11926)
M27	M27 x 2 (ISO 6149)
G12	G 3/4-14 BSPP (ISO 1179-1)

BOX 10: Bypass Options	
Symbol	Description
19	Drain port on bowl
21	Non bypass with drain port
R5	Reverse check option for injector type lube systems

BOX 11: Seal Compound	
Symbol	Description
V	Fluorocarbon

Replacement Elements

Media	Element Collapse Rating	Single Length (Fluorocarbon)	Double Length (Fluorocarbon)
3 Micron	150 psi (10 bar)	HF21L3VQ	HF22L3VQ
3 Micron	2000 psi (138 bar)	HF21H3VQ	HF22H3VQ
5 Micron	150 psi (10 bar)	HF21L5VQ	HF22L5VQ
5 Micron	2000 psi (138 bar)	HF21H5VQ	HF22H5VQ
10 Micron	150 psi (10 bar)	HF21L10VQ	HF22L10VQ
10 Micron	2000 psi (138 bar)	HF21H10VQ	HF22H10VQ

40CN Return Filter

HF3 Series Filters
Low Pressure

40CN Return Filter - up to 800 psi (55 bar) Application

Non-Bypass Option

Mechanical Visual or Electrical Visual Indicator

With 25 DP setting. For electrical indicator options and factory pin wiring, see pages 53-54 (type E and F4M electrical indicators).

Element

HF3 8" Long, 3, 5, and 10 micron element with $b \geq 200$ and dual stage filtering media for up to 40% increased dirt holding capacity.

Mounting Provisions

Pressure Ratings:

Maximum Allowable Operating Pressure (MAOP): 800 psi (55 bar)

Rated Fatigue Pressure: 800 psi (55 bar)

Design Safety Factor: 2.5:1

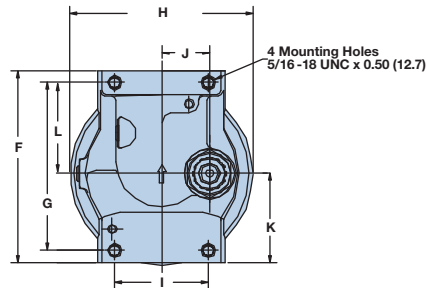
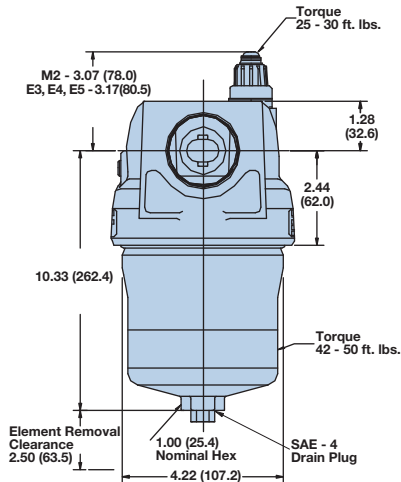

Dimensions are inches (mm)

F	5.00 (127.0)
G	4.37 (111.0)
H	4.80 (121.9)
I	2.44 (62.0)
J	1.25 (31.8)
K	2.32 (58.8)
L	2.37 (60.2)

Assembly ΔP Formula

$$\Delta P_{\text{Assembly}} = \Delta P_{\text{Empty Housing}} + \Delta P_{\text{Element}} \times \frac{\text{New Viscosity}}{150} \times \frac{\text{New Specific Gravity}}{.90}$$

Note: For "H" High collapse elements use 1.4 x ΔP from curves above.

40CN HF3-2 Element Performance

Flow vs. Pressure Loss

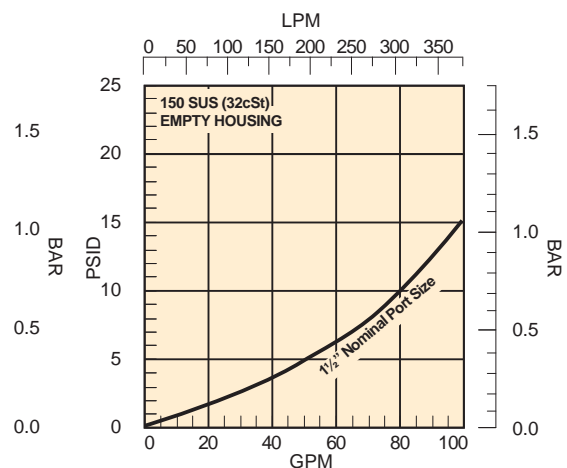
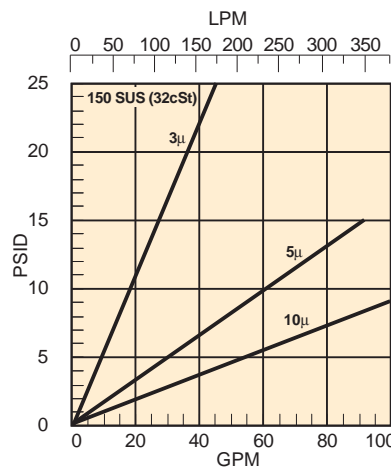

40CN Return Filter: HF3 Series

How to Order

Select the desired symbol (in the correct position) to construct a model code.

Example:

BOX 1	BOX 2	BOX 3	BOX 4	BOX 5	BOX 6	BOX 7	BOX 8	BOX 9	BOX 10	BOX 11
		40CN	2	L	10	E3B	50	ST24	19	V

BOX 1: Division Code	
Symbol	Description
None	Leave Blank
Note: Used for specific automotive program identification.	

BOX 2: Plant Code	
Symbol	Description
None	Leave Blank
Note: Used for specific automotive plant location.	

BOX 3: Configuration	
Symbol	Description
40CN	Hydraulic Filter

BOX 4: Housing Bowl Length	
Symbol	Description
2	1 Element, 8" Long

BOX 5: Element Collapse Rating	
Symbol	Description
H	2000 PSI (138 bar) (-21 option in Box 10 must be selected)
L	150 PSI (10 bar) (-19 option in Box 10 must be selected)

BOX 6: Element Filtration Rating	
Symbol	Description
3	3 Micron Microglass
5	5 Micron Microglass
10	10 Micron Microglass
*Consult factory for other requirements.	

BOX 7: Indicator Type	
Symbol	Description
M2	Visual, Top
E3B*	Electrical/Visual
E4MB*	Electrical/Visual
E4MC*	Electrical/Visual
E5B*	Electrical/Visual
E5MD*	Electrical/Visual
F4MS	Standard Dual output electrical indicator
F4MN	Device Net Dual output electronic indicator
*NOTE: Please refer to indicator drawings and chart on pages 53 and 54 for connector and wiring options.	

BOX 8: Indicator Setting	
Symbol	Description
25	25 psid (1.7 bar)
50	50 psid (3.5 bar)
125	125 psid (8.6 bar) F4M indicator w/ option -21 only.

BOX 9: Port Size	
Symbol	Description
ST24	1 7/8-12 UN-2B (ISO 11926)
M48	M48 x 2 (ISO 6149)
G20	1 1/4-11 BSPP
G24	1 1/2-11 BSPP (ISO 1179G228)

BOX 10: Bypass Options	
Symbol	Description
19	Drain port on bowl
21	Non bypass with drain

BOX 11: Seal Compound	
Symbol	Description
V	Fluorocarbon

Replacement Elements

Media	Element Collapse Rating	Single Length (Fluorocarbon)
3 Micron	150 psi (10 bar)	HF31L3VQ
3 Micron	2000 psi (138 bar)	HF31H3VQ
5 Micron	150 psi (10 bar)	HF31L5VQ
5 Micron	2000 psi (138 bar)	HF31H5VQ
10 Micron	150 psi (10 bar)	HF31L10VQ
10 Micron	2000 psi (138 bar)	HF31H10VQ

IL4/DIL4 Filter

Low Pressure HF4 Series Filters

IL4/DIL4 Filter - 150 psi (10 bar) Application

25# Full Flow Bypass

Mandatory to prevent excessive back pressure into system, which could cause improper adjustments to actuator circuits to meet cycle times.

Visual or Electrical Indicator

With 25 psi (1.7 bar) bypass setting. For electrical indicator options and factory pin wiring, see pages 53-54 (type E electrical indicator).

Elements

3, 5, and 10 micron HF4 elements with $\beta \geq 200$ with dual stage filtering media for up to 40% increased dirt holding capacity.

Upstream and Downstream Test Ports

Allows user to do maintenance troubleshooting.

Single or Double Length

Pressure Ratings:

Maximum Allowable Operating Pressure (MAOP): 150 psi (10 bar)

Rated Fatigue Pressure:

150 psi (10 bar)

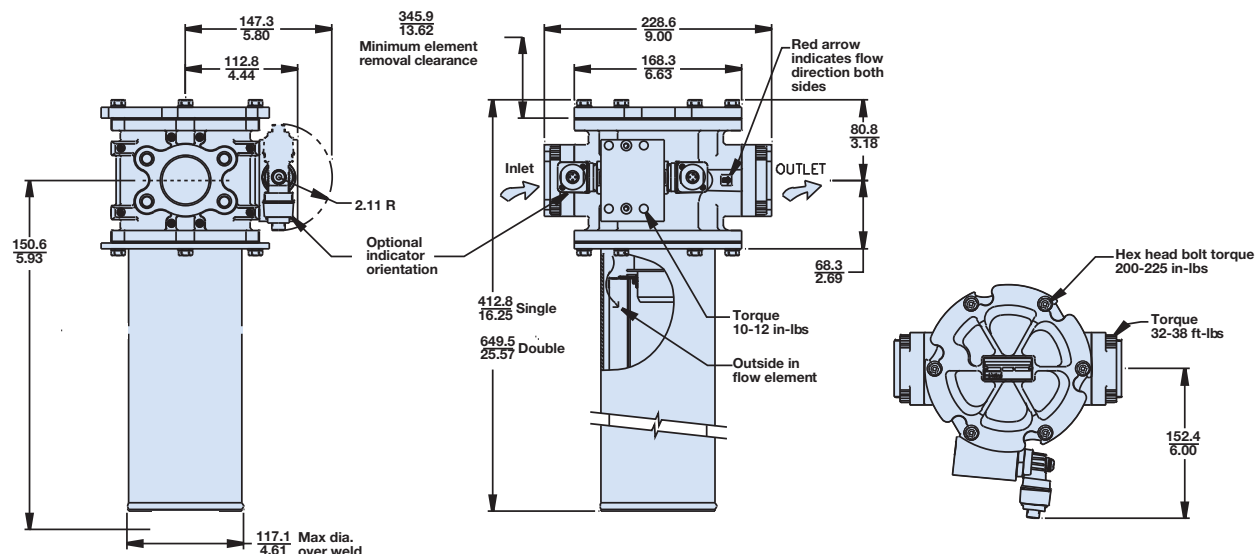
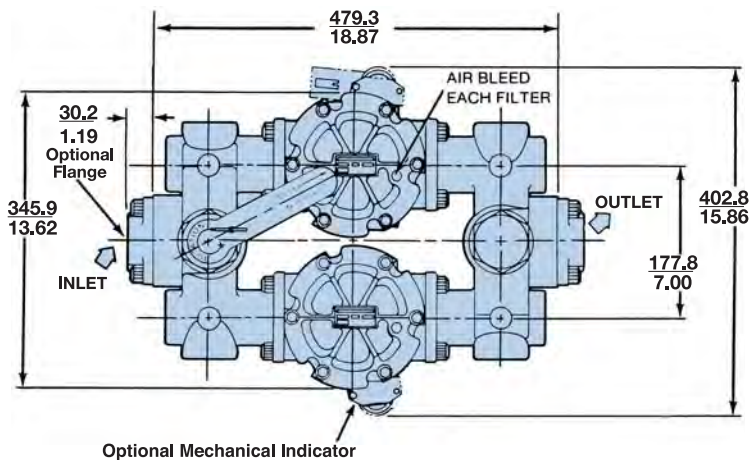

IL4/DIL4 Filter

Performance

IL4-1/DIL4-1 Element Performance

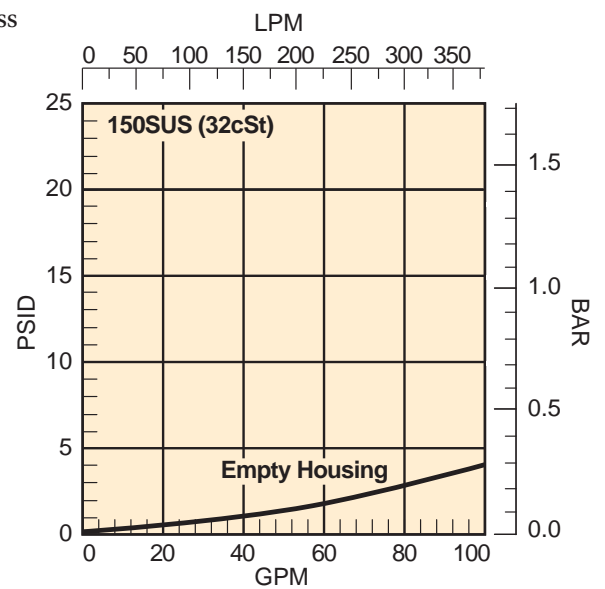
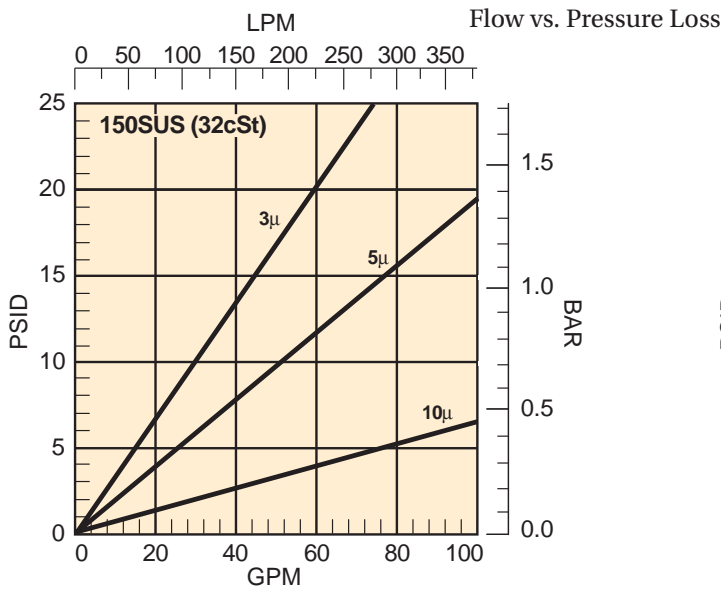

IL4-2/DIL4-2 Element Performance

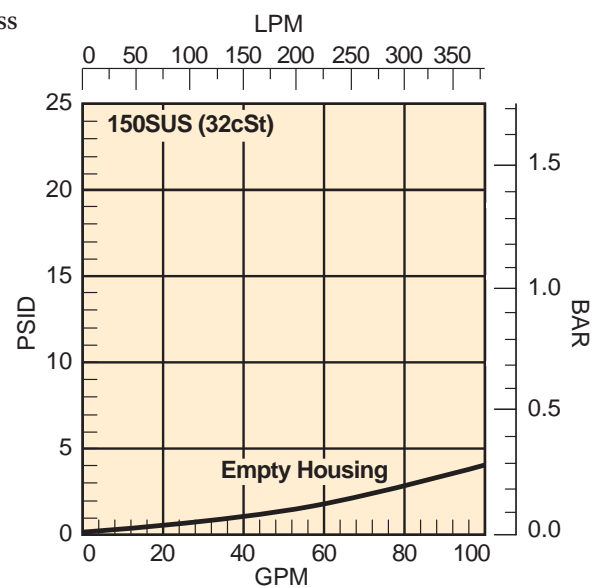
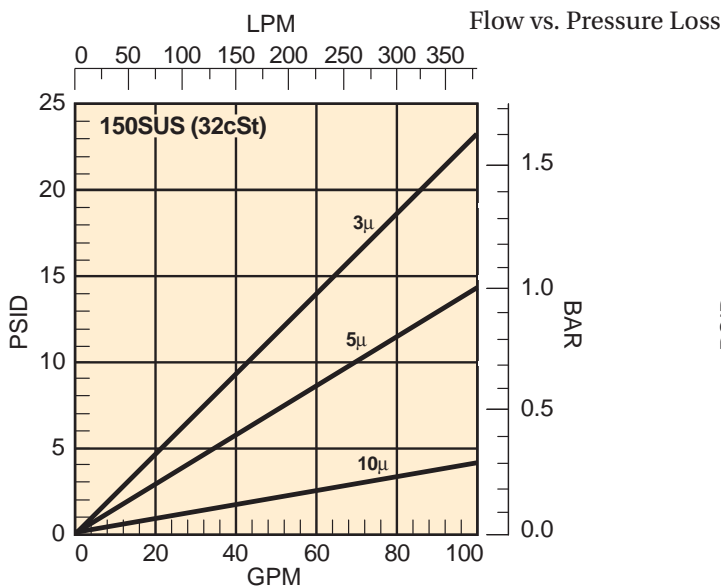

Assembly ΔP Formula

$$\Delta P_{\text{Assembly}} = \Delta P_{\text{Empty Housing}} + \Delta P_{\text{Element}} \times \frac{\text{New Viscosity}}{150} \times \frac{\text{New Specific Gravity}}{.90}$$

Note: For "H" High collapse elements use 1.4 x ΔP from curves above.

IL4/DIL4 Filter: HF4 Series

How to Order

Select the desired symbol (in the correct position) to construct a model code.

Example:

BOX 1	BOX 2	BOX 3	BOX 4	BOX 5	BOX 6	BOX 7	BOX 8	BOX 9	BOX 10
		IL4	2	L	10	E5MD	25	FM	V

BOX 1: Division Code	
Symbol	Description
None	Leave Blank
Note: Used for specific automotive program identification.	

BOX 2: Plant Code	
Symbol	Description
None	Leave Blank
Note: Used for specific automotive plant location.	

BOX 3: Configuration	
Symbol	Description
IL4	In-line Return Filter
DIL4	In-line Duplex Filter

BOX 4: Housing Bowl Length	
Symbol	Description
1	Single Length
2	Double Length

BOX 5: Element Collapse Rating	
Symbol	Description
L	150 PSI (10 bar)

BOX 6: Element Filtration Rating	
Symbol	Description
3	3 Micron Microglass
5	5 Micron Microglass
10	10 Micron Microglass

BOX 7: Indicator Type	
Symbol	Description
IR	Visual, Right Side
IL	Visual, Left Side
E3B*	Electrical/Visual
E4MB*	Electrical/Visual
E4MC*	Electrical/Visual
E5B*	Electrical/Visual
E5MD*	Electrical/Visual

*NOTE: Please refer to indicator drawings and chart on pages 53 and 54 for connector and wiring options. Located at left side of inlet — for right side, add "R" to symbol. Example: E3BR.

BOX 8: Indicator Setting	
Symbol	Description
25	25 psid (1.7 bar)

BOX 9: Port Size	
Symbol	Description
ST24	1 7/8-12 UN-2B (ISO 11926)
G24	1 1/2-11 BSPP (ISO 1179G-228)
FS	2" Flange (ISO 6162), 1/2-13 bolt holes, 3/4" deep
FM	2" Flange (ISO 6162), M12 x 1-3/4 bolt holes, 19.5 mm deep

BOX 10: Seal Compound	
Symbol	Description
V	Fluorocarbon

Replacement Elements

Media	Element Collapse Rating	Single Length (Fluorocarbon)	Double Length (Fluorocarbon)
3 Micron	150 psi (10 bar)	HF41L3VQ	HF42L3VQ
5 Micron	150 psi (10 bar)	HF41L5VQ	HF42L5VQ
10 Micron	150 psi (10 bar)	HF41L10VQ	HF42L10VQ

IL8/HDIL8 Filter

Low Pressure

IL8/HDIL8 Filter - 300 psi (20 bar) Applications

- Lube oil systems
- Power generation plants
- Test stands
- Primary metal equipment
- Pulp & paper equipment
- Offshore drilling and oil patch
- Flushing skids

IL8 series filters are excellent choices for your demanding applications whether you require simplex, duplex or quadplex assemblies.

Wherever high flow or high capacity filters are required, the IL8 series can be applied with confidence.

Filter housings have a simple yet critical job... securely contain the filter element with positive internal sealing.

The IL8 series filter housings are the result of careful engineering. High grade materials are used to provide strength at critical stress points.

The cover and base are anodized aluminum, the handle is nickel plated ductile iron and the bowl is rugged carbon steel. The result is a reliable high performance filter for an array of applications.

Cover

- Handle protects indicators from damage
- Easy on, easy off, for fast service

Indicators

- You can tell element condition at a glance
- Both visual and electrical available

Air Bleed

- Helps protect bearings and other sensitive components from trapped air

Fill Port

- Prefilter the fluid, before it gets into the machine's system
- Purge air while filling

Bowl

- Rugged cold drawn steel—excellent fatigue resistance
- Three sizes for any application: Single (8"), Double (16"), and Triple (39")

Ports

- SAE straight thread or flange face

Drain Port (not visible)

- Clean and easy servicing
- Lets you drain bowl of fluid before element changes

Bypass Valve (not visible)

- Soft seat design for zero internal leakage
- Located in cover assembly

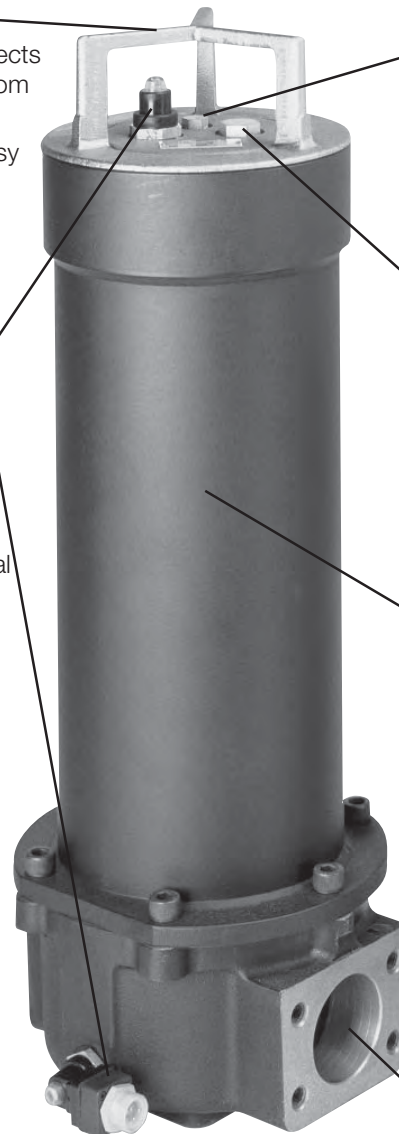

IL8/HDIL8 Filter

Low Pressure

Ecoglass III - Replacement Elements

Ecoglass III represents the merging of high performance filtration technology with environmentally conscious engineering. The Ecoglass III line of replacement elements feature 100% non-metallic construction. The design reduces solid waste and minimizes disposal costs for industry. The non-metallic construction means lightweight elements (60% less weight) for easier servicing.

The Ecoglass III elements utilizes the same proprietary media design as our Microglass III line of replacement elements.

With Ecoglass III, a reusable core is installed into the filter housing and remains in service throughout the life of the assembly.

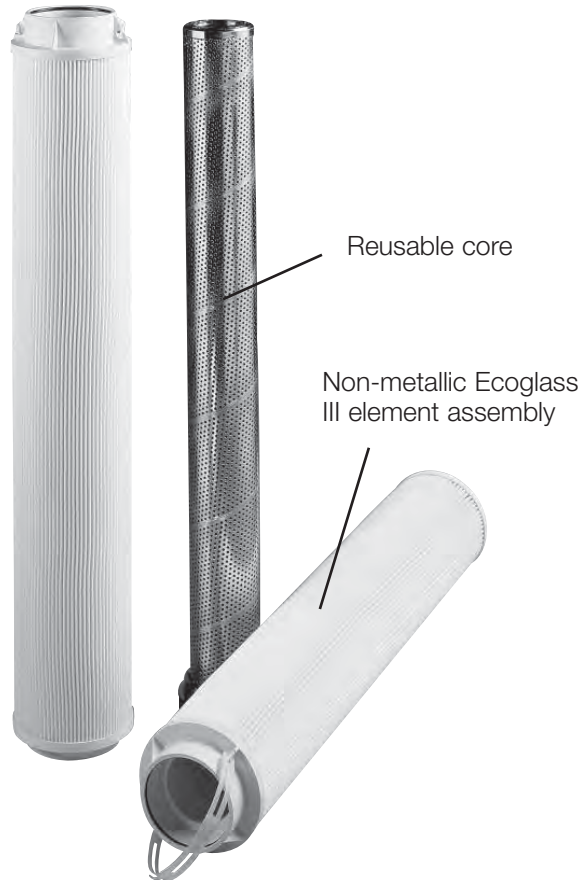

Microglass III - Replacement Elements

Microglass III represents a leap forward in the performance obtainable in hydraulic and lube filter elements.

The unique multi-layer design combines high efficiencies with exceptional dirt holding capacities for performance that is unequalled in the industry today. This performance is further

enhanced in the IL8 series with the introduction of the deep pleat design. The deep pleat element design increases the amount of media in the element and therefore capacity.

With Microglass III you do not have to make a compromise between efficiency and capacity, you can have both.

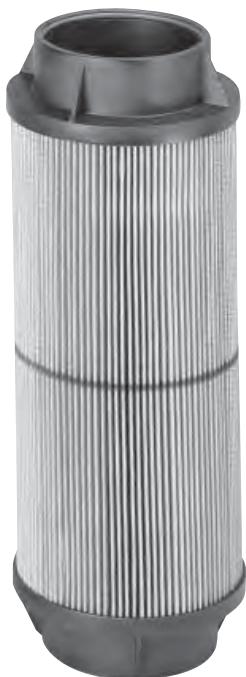

IL8/HDIL8 Filter

IL8-1 Performance

IL8-1 Element Performance

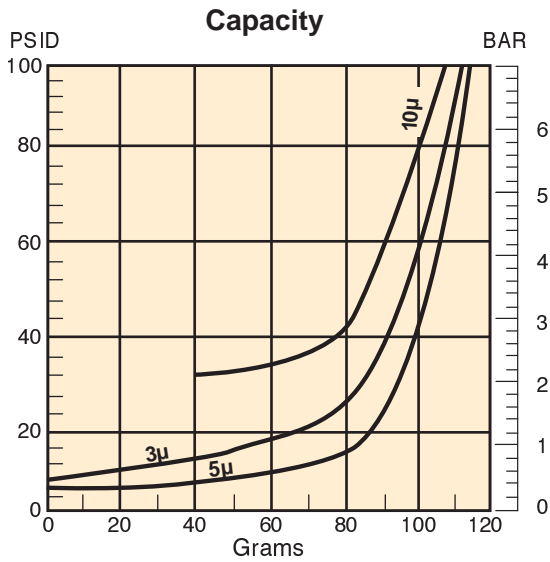

Flow vs. Pressure Loss

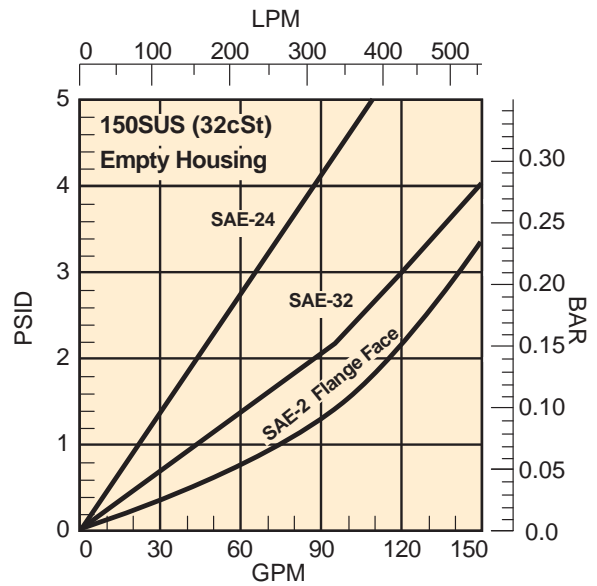
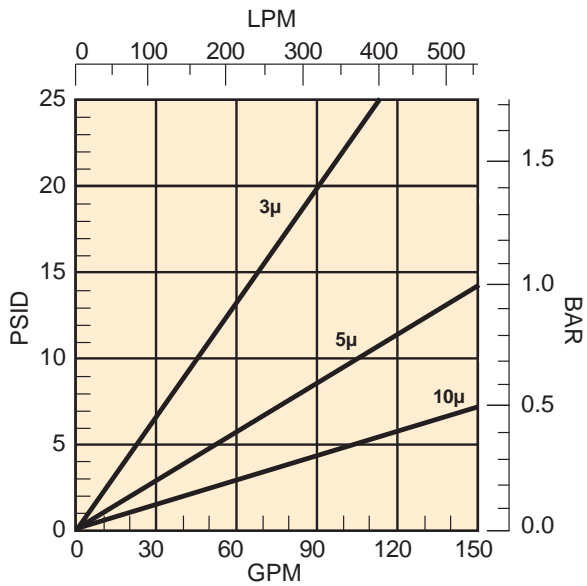

IL8/HDIL8 Filter

IL8-2 Performance

IL8-2 Element Performance

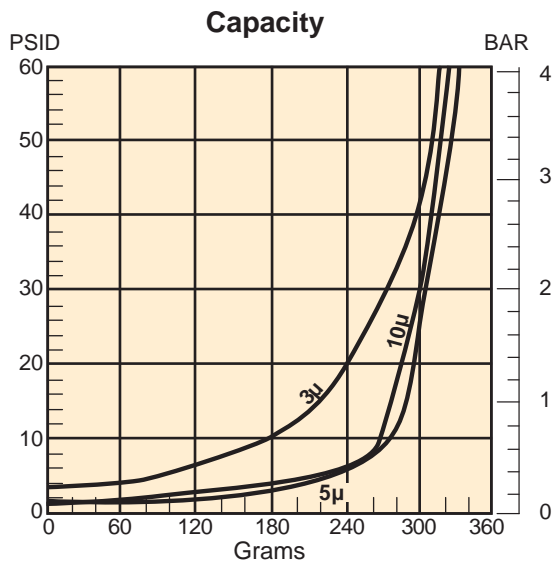

Multipass tests run @ 50 gpm to 50 psid terminal - 10mg/L BUGL

Flow vs. Pressure Loss

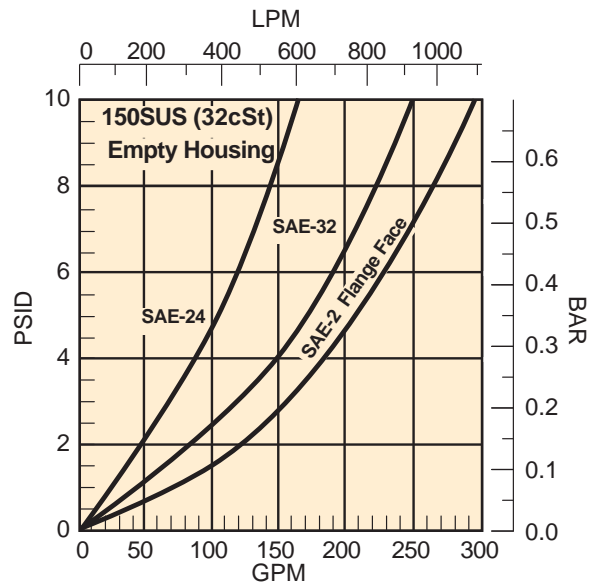
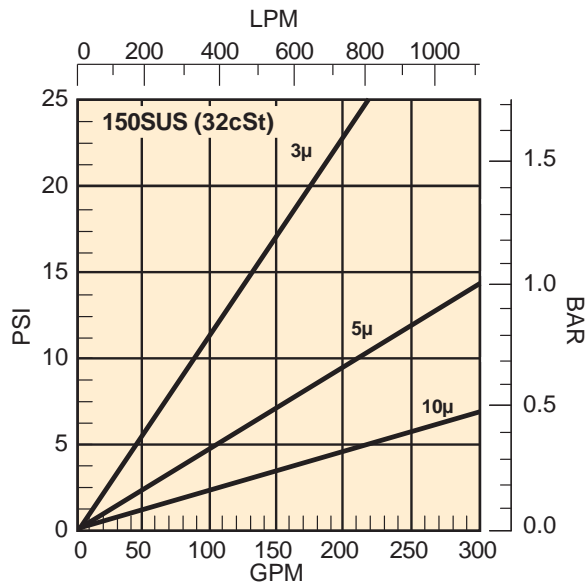

IL8/HDIL8 Filter

IL8-3 Performance

IL8-3 Element Performance

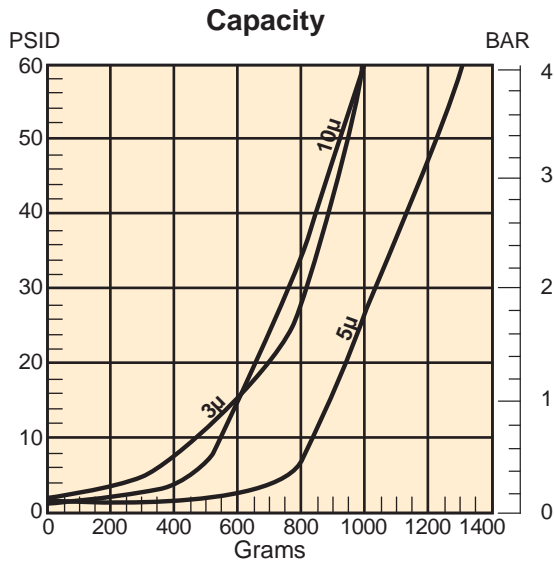

Multipass tests run @ 70 gpm to 50 psid terminal - 10mg/L BUGL

Flow vs. Pressure Loss

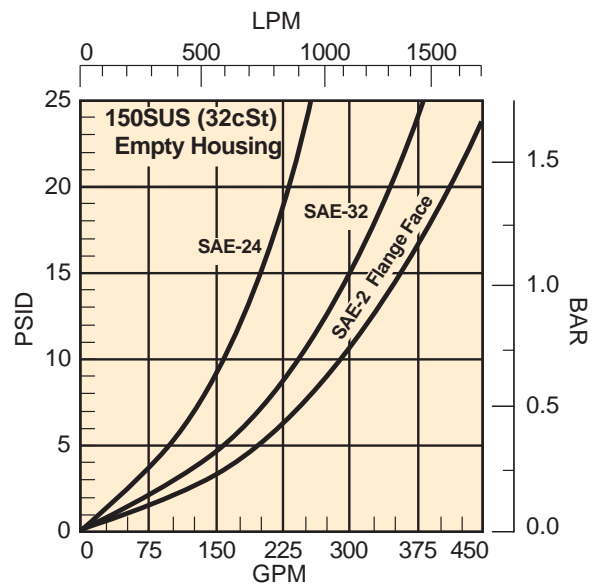
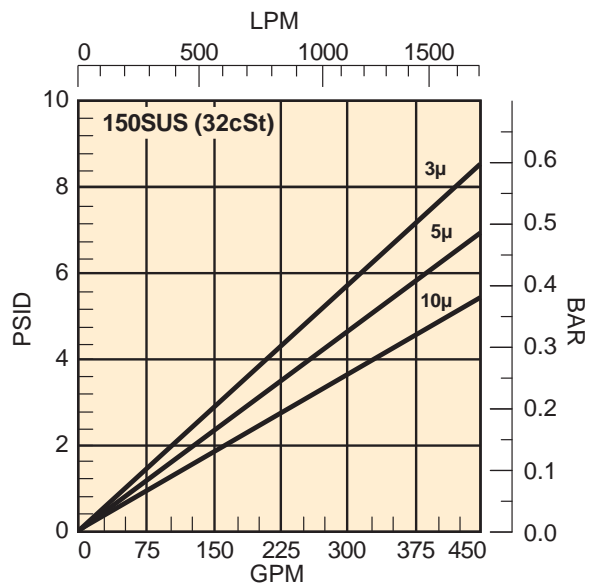

IL8 Filter

Specifications

Pressure Ratings:

Maximum Allowable Operating Pressure (MAOP): 500psi (34.5 bar)

Rated Fatigue Pressure: 330 psi (22 bar)

Design Safety Factor: 3:1

Operating Temperatures:

Buna: -40°F (-40°C) to 225°F (107°C)

Fluorocarbon: -15°F (-26°C) to 275°F (135°C)

Element Collapse Rating:

150 psid (10 bar)

Element Condition Indicators:

Visual (optional)

Electrical -heavy duty (optional)

SPDT .25 amps (resistive) MAX 5 watts 12 to 28 VDC & 110 to 175 VAC

Note: Product of switching voltage and current must not exceed wattage rating

Materials:

Bowl: low carbon steel

Cover: anodized aluminum

Handle: nickel plated ductile iron

Base: anodized aluminum

Shipping Weights

(approximate):

Single: 40 lbs. (18.1 kg)

Double: 50 lbs. (22.7 kg)

Triple: 75 lbs. (34 kg)

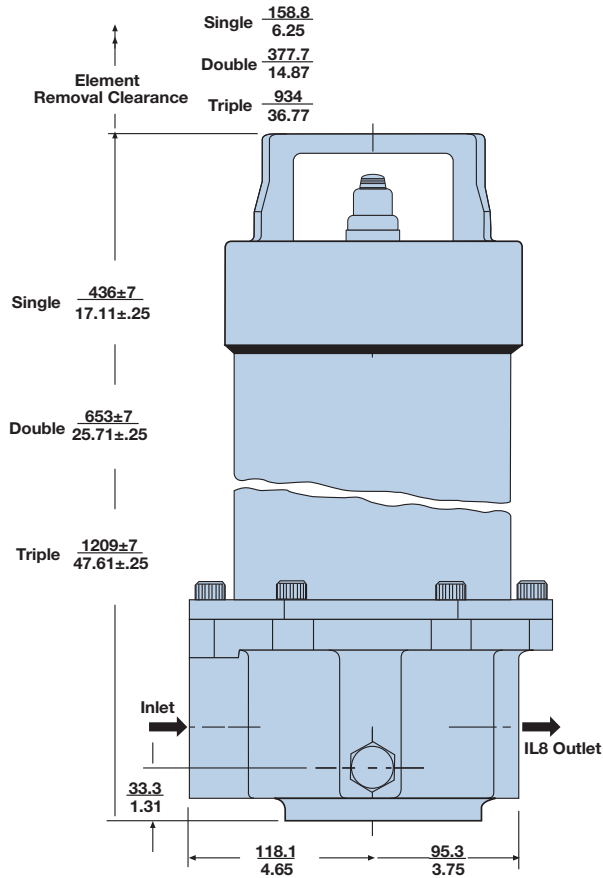

Linear Measure:
 $\frac{\text{millimeter}}{\text{inch}}$

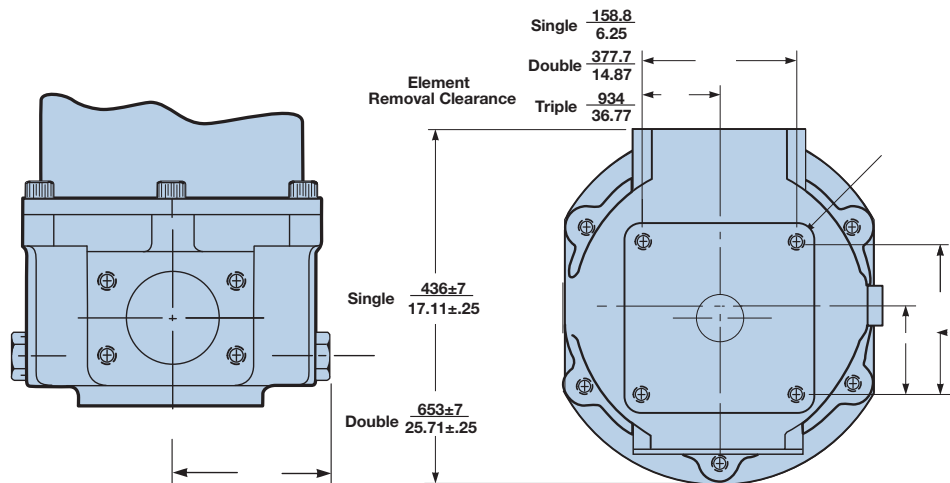

HDIL8/HQIL8 Filter

Specifications

Pressure Ratings:

Maximum Allowable Operating Pressure (MAOP): 400psi (27 bar)
 Rated Fatigue Pressure: 330psi (22 bar)
 Design Safety Factor: 2.5:1

Shipping Weights (approximate):

HDIL8-2	320 lbs. (145 kg)
HDIL8-3	375 lbs. (170 kg)
HQIL8-2	525 lbs. (238 kg)
HQIL8-3	650 lbs. (295 kg)

Operating Temperatures:

-15°F (-26°C) to 200°F (93°C)

Element Collapse Rating:

150 psid (10 bar)

Materials:

Changeover valve: steel
 Bowl: low carbon steel
 Cover: anodized aluminum
 Cover handle: nickel plated ductile iron
 Base: steel

Changeover Valve Flow vs. Pressure Loss

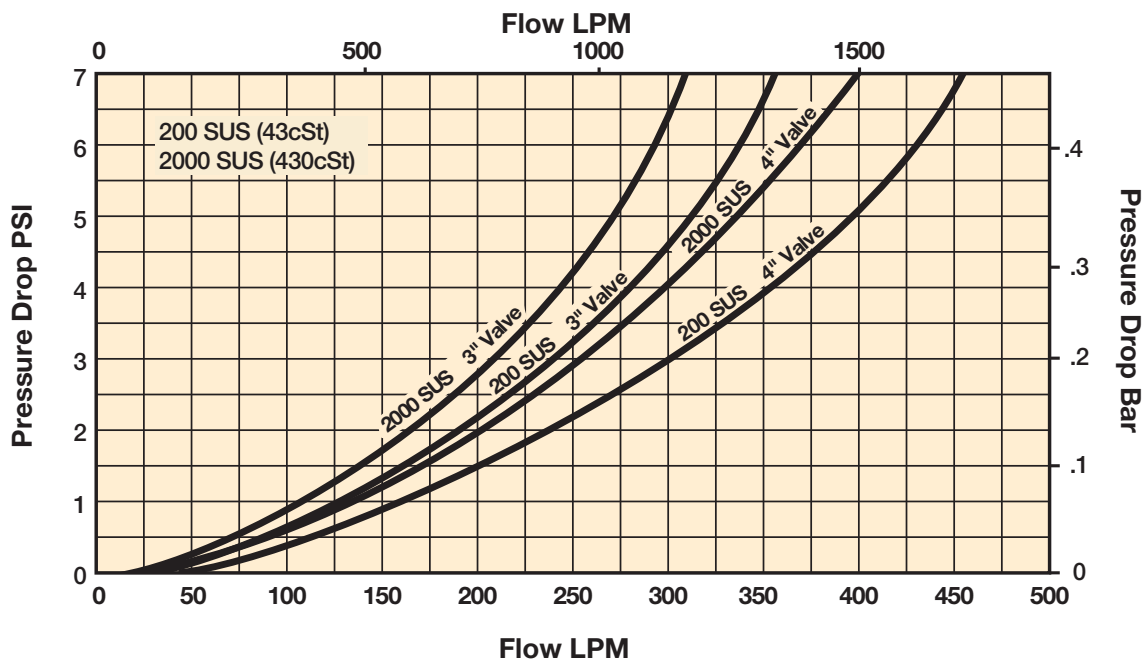

HDIL8/HQIL8 Filter

Specifications

Linear Measure: millimeter
inch

HDIL8 Top View

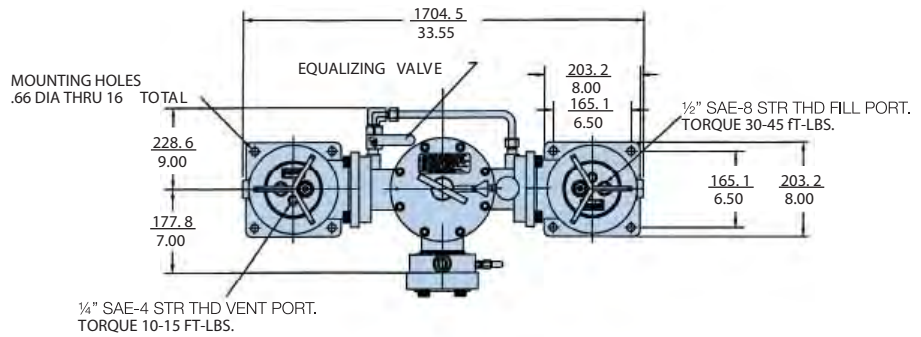

HDIL8/HQIL8 Side View

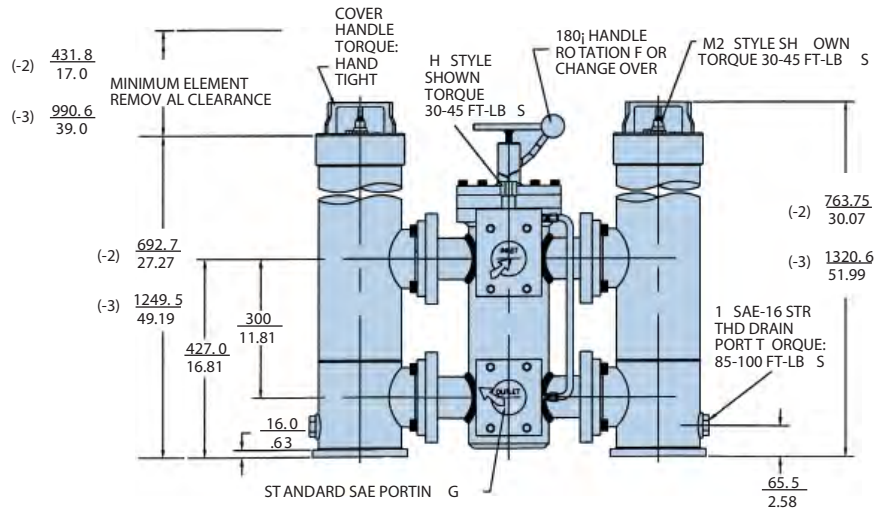

HQIL8 Top View

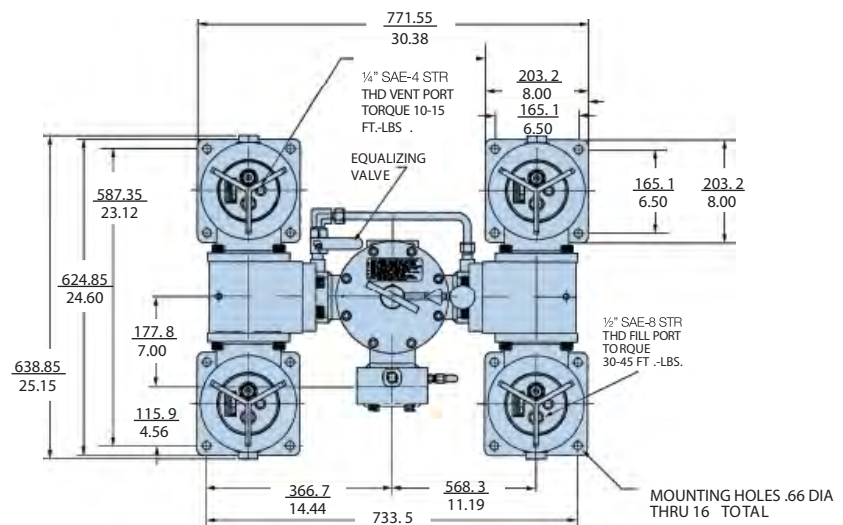

IL8/HDIL8/HQIL8 Filter

How to Order

Select the desired symbol (in the correct position) to construct a model code.

Example:

BOX 1	BOX 2	BOX 3	BOX 4	BOX 5	BOX 6	BOX 7	BOX 8	BOX 9	BOX 10	BOX 11
		IL8	3	R	10QE	E3BP	50	ST24	1	V

BOX 1: Division Code	
Symbol	Description
None	Leave Blank
Note: Used for specific automotive program identification.	

BOX 2: Plant Code	
Symbol	Description
None	Leave Blank
Note: Used for specific automotive plant location.	

BOX 3: Configuration	
Symbol	Description
IL8	In-line Hydraulic Filter
HDIL8	In-line Duplex Filter
HQIL8	In-line Quadplex Filter

BOX 4: Housing Bowl Length	
Symbol	Description
1*	Single Length
2	Double Length
3	Triple Length
*NOTE: Not available for HDIL8 or HQIL8.	

BOX 5: Core	
Symbol	Description
None	Disposable Core
R	Reusable Core

BOX 6: Element Filtration Rating	
Symbol	Description
3	3 Micron Microglass
5	5 Micron Microglass
10	10 Micron Microglass
02QE	Ecoglass III
05QE	Ecoglass III
10QE	Ecoglass III
NOTE: Ecoglass III elements must utilize -R option in Box 4.	

BOX 7: Indicator Type	
Symbol	Description
P	Port Plugged
M2	Visual Auto Reset
IR	Visual, Right Side
IL	Visual, Left Side
E3B*	Electrical/Visual
E4MB*	Electrical/Visual
E4MC*	Electrical/Visual
E5B*	Electrical/Visual
E5MD*	Electrical/Visual
F4MS	Standard Dual output electrical indicator
F4MN	Device Net Dual output electronic indicator
NOTE: Two symbols required. First is for housing, second is for the cover(s). Electrical indicators only available on the housing.	
*Please refer to indicator drawings and chart on pages 53 and 54 for connector and wiring options.	

BOX 8: Indicator Setting	
Symbol	Description
25	25 psid (1.7 bar)
50	50 psid (3.5 bar)
125	125 psid (8.6 bar) F4M indicator w/ option -11 only.

BOX 9: Port Size	
Symbol	Description
	IL8
FS	SAE 2" Flange Face (code 61)
	HDIL8/HQIL8
FS3	3" SAE Flange Face (code 61)
FS4	4" SAE Flange Face (code 61)

BOX 10: Options	
Symbol	Description
1	None
11	Blocked bypass

BOX 11: Seal Compound	
Symbol	Description
V	Fluorocarbon

Replacement Elements

Microglass III (Fluorocarbon)				Ecoglass III (Fluorocarbon)			
Media	Single	Double	Triple	Media	Single	Double	Triple
3	927663Q	933044Q	932872Q	02QE	NA	933834Q	933734Q
5	927861Q	933045Q	932873Q	05QE	NA	933835Q	933612Q
10	927661Q	933046Q	932874Q	10QE	NA	933836Q	933735Q
				Reusable Core	NA	933838	933636

Splash Lube Filter

Special Applications Filters

Splash Lube Filters - 150 psi Application

Non-Bypass Design

10 and 25 Micron Cellulose

Electrical or Gauge Indicator

With 25 psi (1.7 bar) ΔP setting.
For electrical indicator options
and factory pin wiring,
see pages 53-54.

Prevention Feature

Prevents filter operation without
element in place.

Mounting Provisions

Located on top of filter.

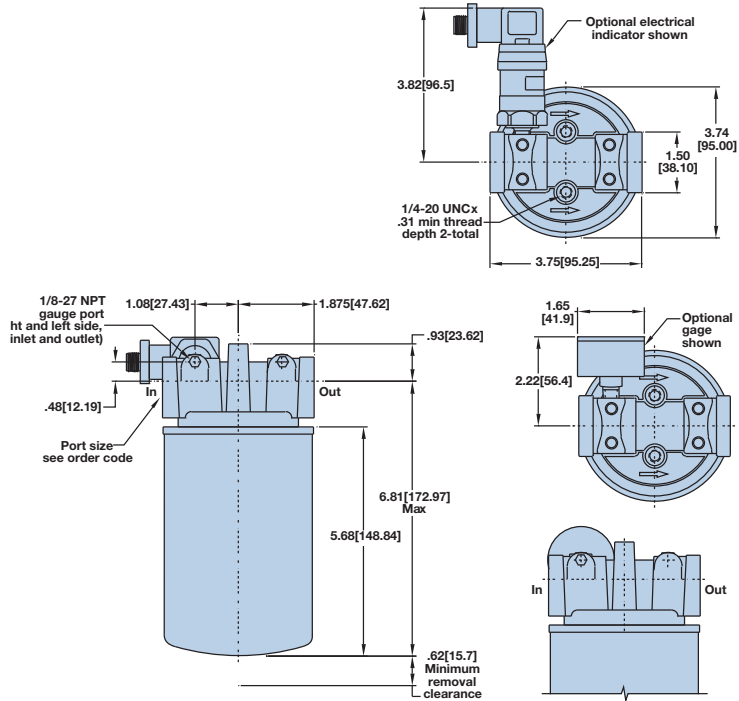
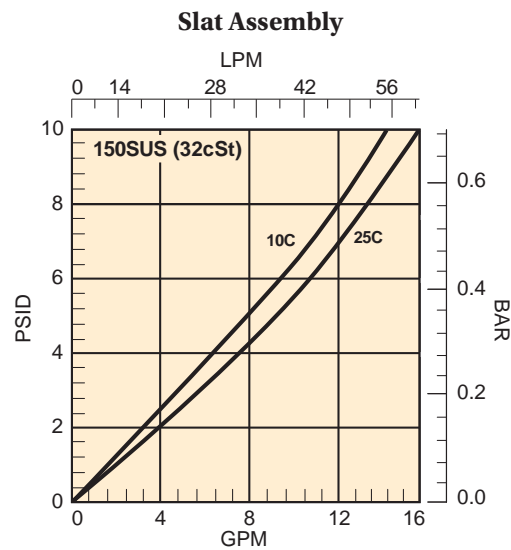

Assembly ΔP Formula						
ΔP	=	ΔP Empty Housing+	x	$\frac{\text{New Viscosity}}{150}$	x	$\frac{\text{New Specific Gravity}}{.90}$
Assembly		Element ΔP				

Note: For "H" High collapse elements use 1.4 x ΔP from curves above.

Splash Lube Filter

How to Order

Select the desired symbol (in the correct position) to construct a model code.

Example:

BOX 1	BOX 2	BOX 3	BOX 4	BOX 5	BOX 6	BOX 7	BOX 8
		SLAT	10C	G	25	ST12	N

BOX 1: Division Code	
Symbol	Description
None	Leave Blank
Note: Used for specific automotive program identification.	

BOX 2: Plant Code	
Symbol	Description
None	Leave Blank
Note: Used for specific automotive plant location.	

BOX 3: Configuration	
Symbol	Description
SLAT	Splash Lube 12AT

BOX 4: Canister Media	
Symbol	Description
10C	10 Micron Cellulose
25C	25 Micron Cellulose

BOX 5: Indicator Type	
Symbol	Description
G	Gauge, Left Side
PS3*	Pressure switch, left side with 3-pin Brad Harrison style connection
PS4*	Pressure switch, left side with 4-pin Brad Harrison style connection
PS5*	Pressure switch, left side with 5-pin Brad Harrison style connection
*Please refer to indicator drawings and chart on pages 53 and 54 for connector and wiring options. Example: PS4MD. Located at left side of inlet, for right side add -R to symbol. Example: PS4MDR.	

BOX 6: Indicator Setting	
Symbol	Description
25	25 psid (1.7 bar)

BOX 9: Port Size	
Symbol	Description
P12	3/4-14 NPT
ST12	1 1/16-12 UN-2B (ISO 11926)
M27	M27 x 2 (ISO 6149)
G12	3/4-14 BSPP (ISO 1179 G228)

BOX 8: Seal Compound	
Symbol	Description
N	Nitrile

Replacement Canisters

Symbol	Part Number
10C	921999
25C	925023

Electrical Information

Pictorial Guide and Specifications



HF2, HF3, HF4
Type E Electrical Indicator



DC3 Pressure Switch
Type SE Electrical Housing



SLAT
Type PS Electrical Indicator

F4M Electronic Indicator

	Part Number	Indication Pressure
PNP N/C Standard	937037	8.5 bar (125 psi)
PNP N/C Device Net	937409	8.5 bar (125 psi)



937037: 4-pin Micro Receptacle
Standard Factory Wiring

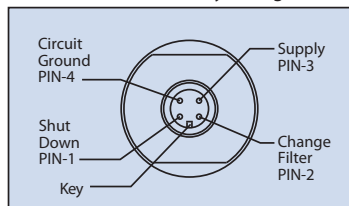

937409: 4-pin Micro Receptacle
Device Net Compatible

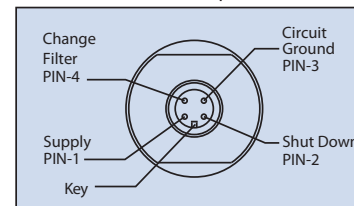

CONTACT CONFIGURATION

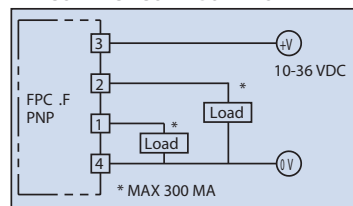

Ind. press	LED status	Output2	Output1
Power on	⊗	Active	Active
50%	⊗ ⊗	Active	Active
75%	⊗ ⊗ ⊗	Inactive	Active
100%	⊗ ⊗ ⊗ ⊗	Inactive	Inactive

SAE Series Filters

Electrical Information

Pictorial Guide and Specifications

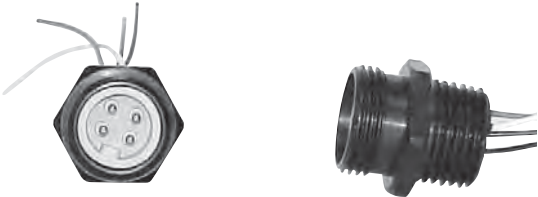

Mini Connector

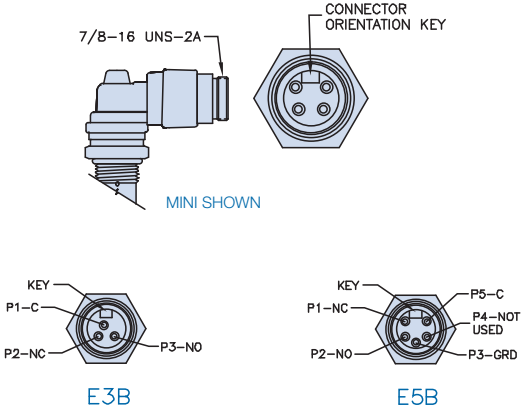

Micro Connector

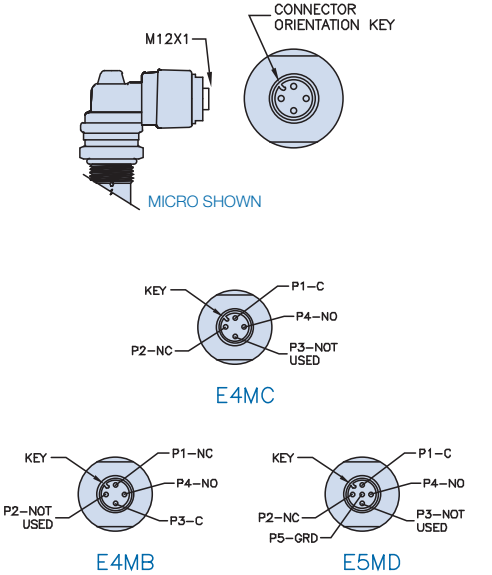

Connector and Wiring Options

PINS	TYPE	WIRING TYPE	PIN 1	PIN 2	PIN 3	PIN 4	PIN 5	E TYPE INDICATORS IND. SWITCH SETTING	
								25 PSI	50 PSI
3	MINI	E3B	C	NC	NO			935952	*
4	MICRO	E4MB	NC	NOT USED	C	NO		935325	934912
4	MICRO	E4MC	C	NC	NOT USED	NO		935722	935723
5	MINI	E5B	NC	NO	GRD	NOT USED	C	934928	934930
5	MICRO	E5MD	C	NC	NOT USED	NO	GRD	934601	934595

*Consult factory



aerospace
 climate control
 electromechanical
filtration
 fluid & gas handling
 hydraulics
 pneumatics
 process control
 sealing & shielding



SMR Series

Submicronic Removal
 Fluid Purification Systems



ENGINEERING YOUR SUCCESS.

SMR Series

Applications

The SMR Series is the smart purification solution for fluid flow in the 2-10 GPM (8 - 38 LPM) range. The SMR contains patented Balanced Charge Agglomeration (BCA™) technology, which maintains hydraulic and lubricating fluids in optimum condition while preventing/removing the build-up of sludge and varnish. The system is available in a PLC or simplified control version.

Balanced Charge Agglomeration (BCA™) technology does not remove water, however with the removal of thousands of sub-micron particles, the majority of sites where water can readily attach are mitigated. Water is more easily separated and removed, improving demulsibility.

- **Power Generation**

- Steam & Gas Turbine
- hydraulics & lubrication

- **Oil & Gas**

- Compressor/Turbine hydraulics & lubrication

- **Pulp & Paper**

- Lube oil
- Hydraulics

- **Manufacturing**

- Hydraulics
- Lubrication
- EDM
- Injection molders

- **Others**

- Cooking oil
- Gear oil
- Fuels
- Bio fuels
- Steel
- Military



SMR Series

Balanced Charge Agglomeration (BCA™) - How the Technology Works

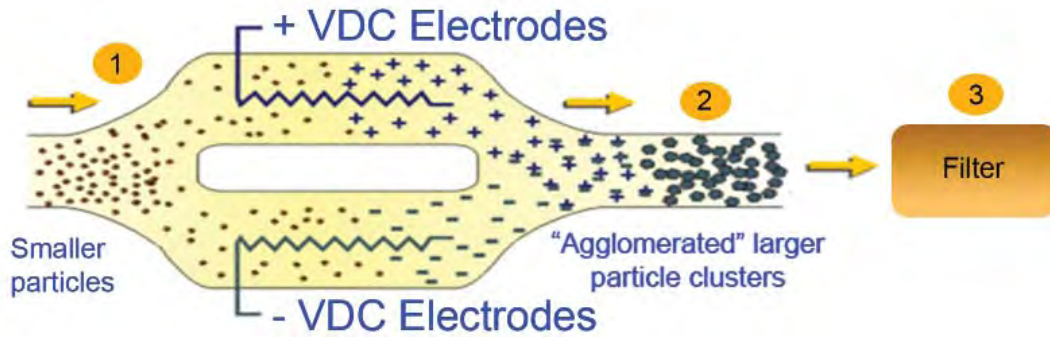

- 1** Particles are passed across high-voltage electrodes, inducing a charge on the particles (+) and (-) in separate paths.
- 2** Oppositely charged particles are mixed and are attracted to each other, forming larger particle clusters.
- 3** Particle clusters are more efficiently filtered.

Evaluation of the SMR Process - Actual Test Results

- Varnish is stripped from the hydraulic or lubrication system as fluid is processed through the SMR.
- The varnish is suspended in the hydraulic fluid as sub-micron particulate.
- BCA™ develops larger particles (see graphic above).
- The particulate is effectively removed from the hydraulic or lubrication fluid by high efficiency filters.



Result 1



Result 2



Result 3



Result 4



Result 5



Result 6



Result 7



Result 8



Result 9



Result 10

Results from a 10 month field trial

SMR Series

Features and Benefits

- Contaminant Removal to the Sub-Micron Level
- Prevention and Removal of Sludge and Varnish
- Removal of Oxidation Byproducts and Biological Contamination
- Removal of Ferrous and Non-Ferrous Contaminants

The Parker SMR Benefit

- Unmatched Fluid Purification & System Polishing
- Proven Varnish Removal
- PLC Control & Data Tracking
- OEM Approvals



SMR2

Element Performance

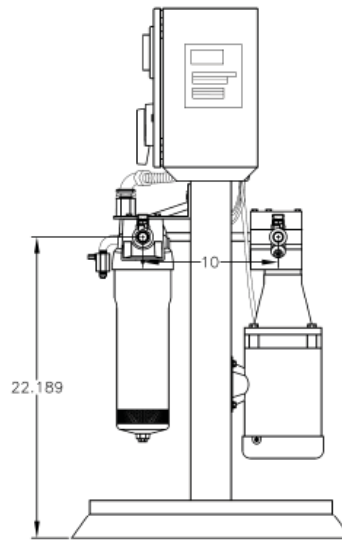
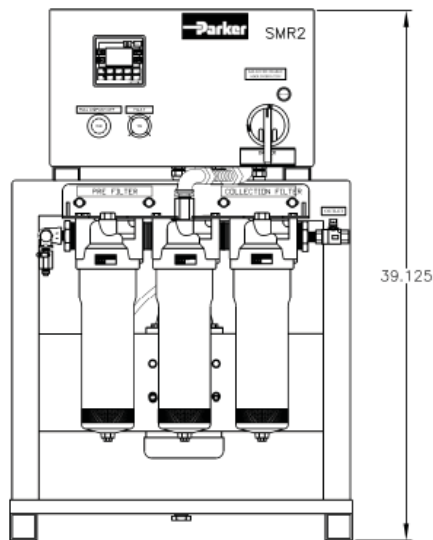
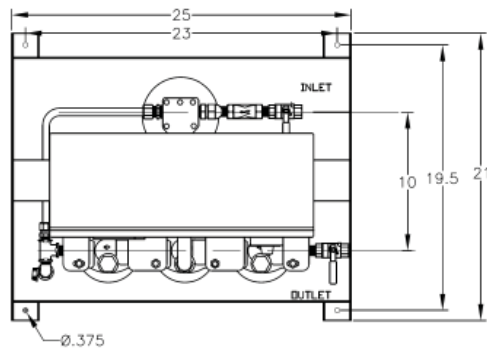
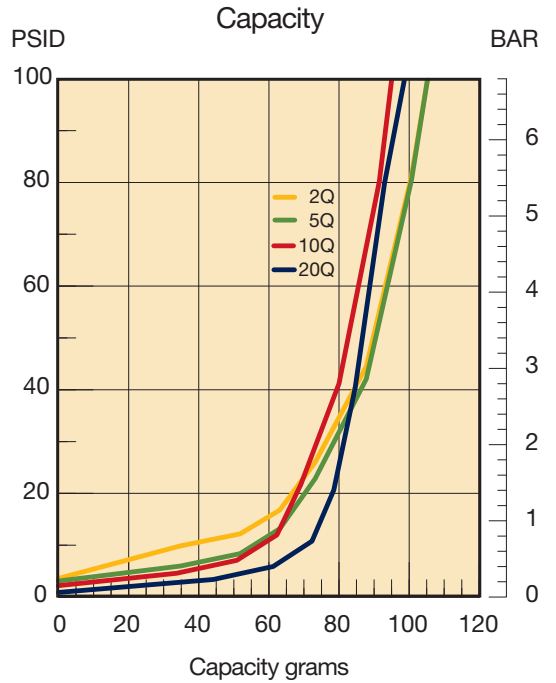
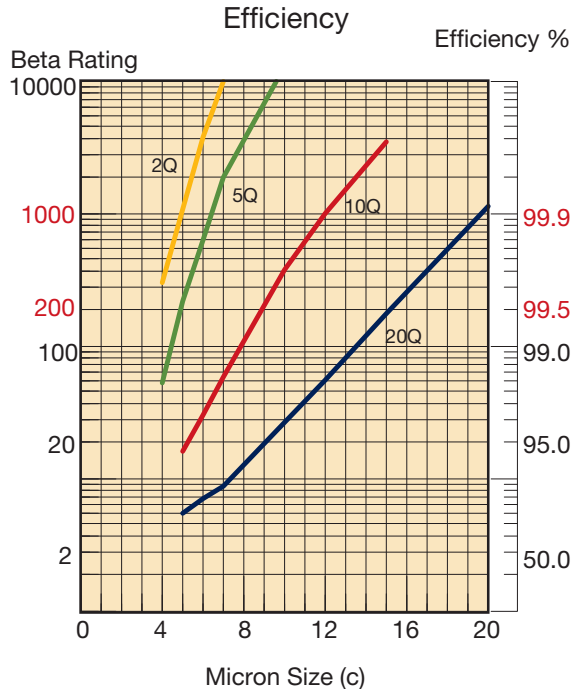

Dimensions are in inches.

Drawings are for reference only. Contact factory for current version.

SMR2

Specifications

Fluid

Viscosity: 1,020 SUS (220 cSt) maximum
Maximum Pressure: 50/80 PSI (operating/static)
Minimum Fluid Temperature: 65° F (18° C)
Maximum Fluid Temperature: 200° F (93° C)
Minimum Fluid Flash Point: >140° F (60° C)

Power

Customer Provided
Voltage: 110VAC/1Ph/60Hz, 230VAC/3Ph/60Hz, 460VAC/3Ph/60Hz
Phase: 1/3
Frequency 60Hz

Motor

Power: 0.5 HP
Voltage/Ph/Freq: 0-230/460/3/variable
RPM: 0 to 2000

Pump

Positive Displacement - Variable Frequency Drive (VFD)
Design Flow Rate: 0.5 - 2.5 GPM

Parameter Settings			
Parameter	Default	Minimum	Maximum
Flow	2 GPM [7.58 LPM]	0.5 GPM [1.9 LPM]	2.5 GPM [9.45 LPM]
Shutdown Pressure	70 psi [4.82 bar]	0 psi/bar	75 psi [5.17 bar]
Max Operating Pressure	50 psi [3.4 bar]	0 psi/bar	60 psi [4.13 bar]
Min Operating Pressure	0 psi [0.0 bar]	0 psi/bar	5 psi [0.34 bar]
Maximum Temperature	200° F [93.3°C]	35° F [1.6°C]	200° F [93.3°C]
Minimum Temperature	35° F [1.5°C]	35° F [1.6°C]	200° F [93.3°C]
Upstream Filter Delta-P	15 psi [1.0 bar]	5 psi [0.34 bar]	25 psi [1.7 bar]
Downstream Filter Delta-P	10 psi [0.67 bar]	5 psi [0.34 bar]	25 psi [1.7 bar]
Auto-Restart after power loss	OFF	n/a	n/a
Auto-Restart after temperature shutdown	OFF	n/a	n/a
US or Metric units	US		

SMR2

Parts List

Quantity	Parker Part #	Description
1	165-00002	Drive, AC, A/B .5 HP 240V 1 PH
	165-00001	Drive, AC, A/B .5 HP 480V 3 PH
	165-00011	Drive, Line Filter, .5 HP 120V & 240V 1 PH
	165-00014	Drive, Line Filter, .5 HP 460V 3 PH
1	270-00006	PLC/HMI
1	275-00007	Power Supply, H.V.
1	275-00002	Power Supply, A/B 24V 110-240V
1	275-00006	Power Supply, C/H 24V 380-480V
1	290-00001	Relay, H.V., A/B
1	245-00006	Light Module, A/B, Green
1	245-00005	Light Module, A/B, Yellow
1	250-00005	Motor, .5 HP, 230-380 STD
1	280-00014	Pump/Bypass, 2 GPM, STD
1	255-00016	O-Ring, vessel 1, 2 or 3
1	936623Q	5 Micron Filter, Upstream
1	936622Q	2 Micron Filter, Downstream
1	195-00003	Feedthru, H.V.
4	350-00001	Transducer, pressure



SMR10

Element Performance

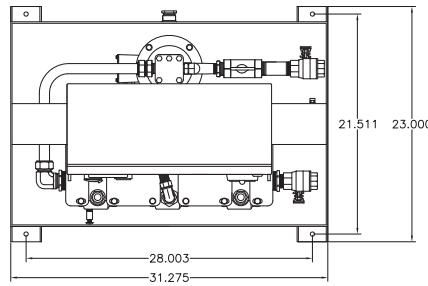
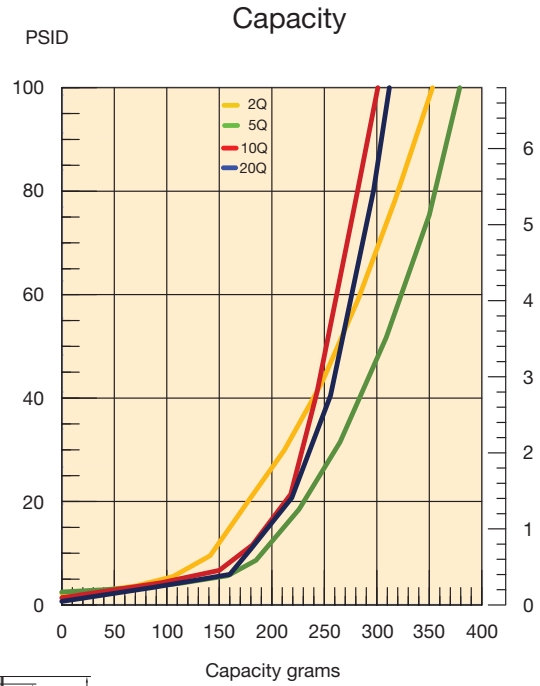
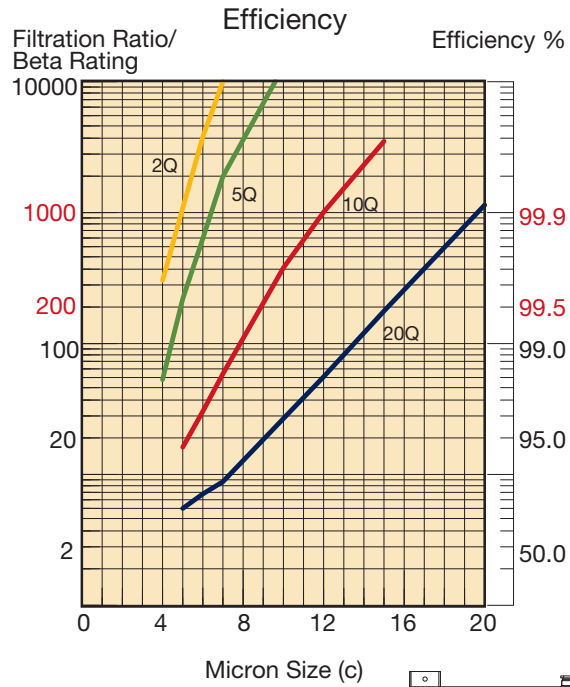

Dimensions are in inches.

Drawings are for reference only.
Contact factory for current version.

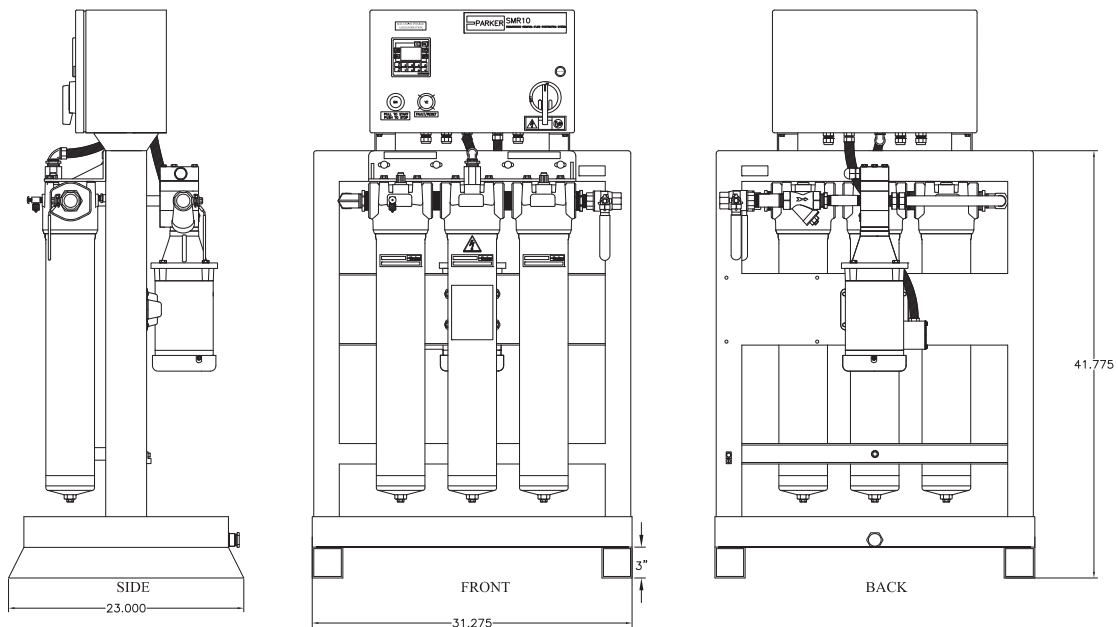

SMR10

Specifications

Fluid

Viscosity: 1,020 SUS (220 cSt) maximum
Maximum Pressure: 50/80 PSI (operating/static)
Minimum Fluid Temperature: 65° F (18° C)
Maximum Fluid Temperature: 200° F (93° C)
Minimum Fluid Flash Point: >140° F (60° C)

Power

Customer Provided
Voltage: 110VAC/1Ph/60Hz, 230VAC/3Ph/60Hz,
460VAC/3Ph/60Hz
Phase: 1/3
Frequency 60Hz

Motor

Power: 0.5 HP
Voltage/Ph/Freq: 0-230/460/3/variable
RPM: 0 to 2000

Pump

Positive Displacement - Variable Frequency Drive (VFD)
Design Flow Rate: 2.5 - 10 GPM

Parameter Settings			
Parameter	Default	Minimum	Maximum
Flow	10 GPM [37.9 LPM]	2.5 GPM [9.45 LPM]	10 GPM [37.85 LPM]
Shutdown Pressure	70 psi [4.82 bar]	0 psi/bar	75 psi [5.17 bar]
Max Operating Pressure	50 psi [3.4 bar]	0 psi/bar	60 psi [4.13 bar]
Min Operating Pressure	0 psi [0.0 bar]	0 psi/bar	5 psi [0.34 bar]
Maximum Temperature	200°F [93.3°C]	35°F [1.6°C]	200°F [93.3°C]
Minimum Temperature	35°F [1.5°C]	35°F [1.6°C]	200°F [93.3°C]
Upstream Filter Delta-P	15 psi [1.0 bar]	5 psi [0.34 bar]	25 psi [1.7 bar]
Downstream Filter Delta-P	10 psi [0.67 bar]	5 psi [0.34 bar]	25 psi [1.7 bar]
Auto-Restart after power loss	OFF	n/a	n/a
Auto-Restart after temperature shutdown	OFF	n/a	n/a
US or Metric units	US		

SMR10

Parts List

Quantity	Parker Part #	Description
1	165-00002	Drive, AC, A/B .5 HP 240V 1 PH
	165-00001	Drive, AC, A/B .5 HP 480V 3 PH
	165-00011	Drive, Line Filter, .5 HP 120V & 240V 1 PH
	165-00014	Drive, Line Filter, .5 HP 460V 3 PH
1	270-00006	PLC/HMI
1	275-00007	Power Supply, H.V.
1	275-00002	Power Supply, A/B 24V 110-240V
1	275-00006	Power Supply, C/H 24V 380-480V
1	290-00001	Relay, H.V., A/B
1	245-00006	Light Module, A/B, Green
1	245-00005	Light Module, A/B, Yellow
1	250-00005	Motor, .5 HP, 230-380 STD
1	280-00014	Pump/Bypass, 2 GPM, STD
1	255-00016	O-Ring, vessel 1, 2 or 3
1	933219Q	5 Micron Filter, Upstream
1	933218Q	2 Micron Filter, Downstream
1	195-00003	Feedthru, H.V.
4	350-00001	Transducer, pressure

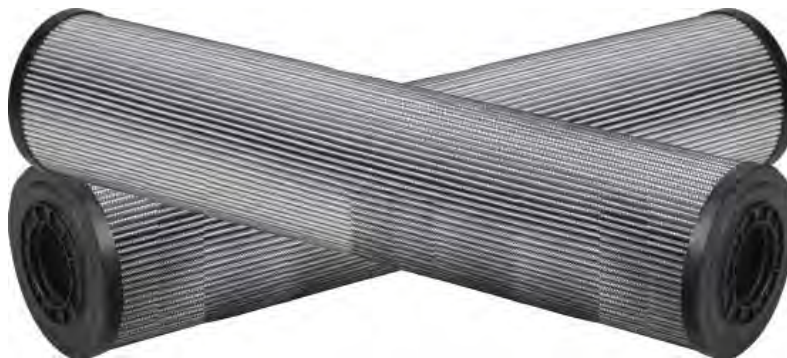

SMR Series

How to Order

Select the desired symbol (in the correct position) to construct a model code.

Example:

BOX 1	BOX 2	BOX 3	BOX 4	BOX 5	BOX 6	BOX 7	BOX 8	BOX 9
SMR	2	460	20QE	V	M2	X	N08	MS

BOX 1: Basic Assembly	
Symbol	Description
SMR	Submicronic Filtration System

BOX 2: Flow Rate	
Symbol	Description
2	2 GPM (7.6 LPM)
10	10 GPM (38 LPM)

BOX 3: Power	
Symbol	Description
120	120VAC, 1Ph, 60Hz
230	230VAC, 3Ph, 60Hz
380	380VAC, 3Ph, 50Hz
460	460VAC, 3Ph, 60Hz
575	575VAC, 3Ph, 60Hz

BOX 4: Element Media ¹	
Symbol	Description
SMR2	
02QE	Ecoglass III, 2 micron
05QE	Ecoglass III, 5 micron
10QE	Ecoglass III, 10 micron
20QE	Ecoglass III, 20 micron
SMR10	
02Q	Microglass III, 2 micron
05Q	Microglass III, 5 micron
10Q	Microglass III, 10 micron
20Q	Microglass III, 20 micron

BOX 5: Seals	
Symbol	Description
V	Fluorocarbon (FKM)
E	Ethylene Propylene (EPR)

BOX 6: Indicator	
Symbol	Description
P	No Indicator
M2	Analog Visual Indicator

BOX 7: Bypass	
Symbol	Description
X	No Bypass

BOX 8: Ports	
Symbol	Description
SMR2	
N08	½" NPT threaded ports
SMR10	
N16	1" NPT threaded ports

BOX 9: Options	
Symbol	Description
SS	Stainless steel wetted parts
EXP	Explosion proof (Class 1, Div. 2, Gp. C & D)
MS	Moisture Sensor
PD ²	Particle Detector
PDM ²	Particle Detector with Moisture Sensor

Note:

1. Outlet polishing filter is always fitted with 02QE/02Q element.

2. icountPD not available when EXP option is selected.

Replacement Elements

Note: "CF" = Consult Factory

SMR2			SMR10		
Ecoglass III Media	Fluorocarbon	Ethylene Propylene	Microglass III Media	Fluorocarbon	Ethylene Propylene
02QE	936622Q	940848Q	02Q	933218Q	CF
05QE	936623Q	940847Q	05Q	933219Q	CF
10QE	936720Q	940846Q	10Q	933220Q	CF
20QE	936721Q	940845Q	20Q	933221Q	CF

PVS Portable Purification System

Fluid Condition Monitoring Offline System

Principles of Operation

Contaminated oil is drawn into the Parker Portable Purification System by a vacuum of 25 In/Hg. The oil passes through the in-line low watt density heater where the oil is heated to an optimum temperature of 150°F (66°C).

The oil then enters the distillation column where it is exposed to the vacuum through the use of special dispersal elements. This increases the exposed surface area of the oil and converts the water to vapor form, which is then drawn through the condenser by the vacuum pump.

The water-free oil falls to the bottom of the column and is removed by a heavy duty lube oil pump. This pump forces the dry oil through a final particulate

removal filter. Clean oil passes out of the unit, back to the reservoir — and into the system.

Effects of Water Contamination

Water is one of the most common contaminants in a fluid system and one of the most damaging. When water contaminates a system, it can cause serious problems such as:

- Corrosion by etching metal
- Fluid breakdown, reduction of lubricating properties, additive precipitation, and oil oxidation
- Reduced dielectric strength
- Abrasive wear in hydraulic components

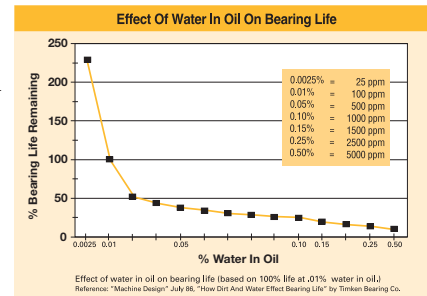

Features	Advantages	Benefits
Variable flow circuit	Allows oil to heat more quickly	Starts to remove water more quickly
Moisture sensor	Real-time water content indication in % saturation	At-a-glance visual confirmation
Automatic operation	Unattended use Designed for 24/7 operation	Reduces labor costs Increases operation time
Stainless steel used for all wetted surfaces	No corrosion	Product reliability
Compact size	Smallest envelope in the industry Ease of portability	Fits in tight areas Encourages use
Clear plexiglass covers on the condensate tank and vacuum chamber	See the vacuum dehydration process work	Visual verification of water removal
Desiccant breather	Insures dry, clean intake air	More efficient operation
Reverse phase switch	Enables easy changing of motor rotation if out-of-phase	Ease of maintenance Prevents incorrect rotation
Condensate holding tank with optional auto drain	Large volume for infrequent servicing intervals	Reduces maintenance costs
Programmable thermostat	Maintains oil within 1°F Prevents overheating the oil	Unattended operation
Forklift guides and lifting eyes	Provides safe and secure method of lifting the unit	Employee safety
Coalescing or packed tower dispersal elements	Flexibility with various fluid viscosities	Greater efficiency in removing moisture

PVS Portable Purification System

How to Order

Product configurator

Select the desired symbol (in the correct position) to construct a model code.

Box 1	Box 2	Box 3	Box 4	Box 5	Box 6	Box 7	Box 8	Box 9	Box 10	Box 11
-	PVS	600	460	DS	D	5Q	-	12	AC	DFL

Box 1

Seals	
Description	Code
Fluorocarbon	None
EPR	E8

Box 2

Basic assembly	
Description	Code
Portable Purification System	PVS

Box 3

Flow rate	
Description	Code
19 lpm (4.2 gpm)	185
38 lpm (8.3 gpm)	600
76 lpm (16.7 gpm)	1200
114 lpm (25.0 gpm)	1800
170 lpm (37.4 gpm)	2700

Box 4

Power supply		
Model	Description	Code
185	380VAC, 3P, 50HZ	380
	460VAC, 3P, 60HZ	460
	575VAC, 3P, 60HZ	550
600	380VAC, 3P, 50HZ	380
	460VAC, 3P, 60HZ	460
	550VAC, 3P, 60HZ	550
1200	380VAC, 3P, 50HZ	380
	460VAC, 3P, 60HZ	460
	550VAC, 3P, 60HZ	550
1800	380VAC, 3P, 50HZ	380
	460VAC, 3P, 60HZ	460
	550VAC, 3P, 60HZ	550
2700	380VAC, 3P, 50HZ	380
	460VAC, 3P, 60HZ	460
	550VAC, 3P, 60HZ	550

Box 5

Vacuum pump	
Pressure setting	Code
Dry sealed	DS
Liquid ring	LR

Box 6

Dispersal element	
Description	Code
Disposable (coalescing)	D
Packed tower (cleanable – for use with viscous or highly contaminated fluids)	P

Box 7

Particulate element µm (c)	
Description	Code
4 micron Microglass III	2Q
6 micron Microglass III	5Q
10 micron Microglass III	10Q
20 micron Microglass III	20Q

Note: Above elements are rated for Beta 200+ (99.5% efficiency)

Box 8

Filter housing	
Description	Code
80CN-2	None
IL8 (39") Ecoglass III upgrade	E

Note: IL8 option is available on 600 models, and is standard on 1200 models and larger

Box 9

Heater		
Model	Description	Code
185	12 KW (3 phase)	12
600	12 KW	12
	24 KW	24
1200	24 KW	24
1800	36 KW	36
2700	48 KW	48

Box 10

Condenser	
Description	Code
Air cooled	AC
Liquid cooled	LC

Box 11

Options	
Description	Code
Pneumatic wheels	PW
Auto condensate drain	ACD
Dirty filter light	DFL
Resetable hour meter	RHM
Sight flow indicator	SFI
Inlet control valve	ICV
CE marked	CE
CSA marked	CSA
Explosion proof	EXP

(Class I, Division II, Zone I and II)



Environmental Air Filters Reservoir Equipment

Automotive Filter Catalog



ENGINEERING YOUR SUCCESS.

EAB Series

Reservoir Equipment

Typical Applications

- Agricultural machines
- Articulated dump trucks
- Forestry equipment
- Wheeled loaders
- Lubricating systems
- Excavators
- Mobile cranes
- Industrial power units

Technical Data

The filter has been designed to achieve a low pressure drop and high dirt holding capacity with airflows up to 1500 l/min (400 gpm). A compact EAB10 with airflows up to 1000 l/min (260 gpm) is also available.

Construction:

Glass reinforced composite housing with Eco-element.

Filter media options:

P020: High quality polyester media. 2µm (abs).

C015: Polyester media with water-resistant layer. 1.5µm (abs)

Q010: Glass fibre media. 1.0µm (abs)

Mounting options:

With 6 screws. Includes machine and plate screws, a strainer and gaskets.

External threads G3/4", G1"

Internal thread G3/4"

Options:

Visual gauge type vacuum/pressure indicator.

Overpressure valve, pressure setting 0.2 bar (2.9 psi). (available for EAB20 only)

EAB10 cannot be specified with an overpressure valve and vacuum/pressure gauge at the same time.

Advantages of the EAB filters:

Easy maintenance.

Indicator states the need for element change.

Quick and easy element change (no tools required).

Environmentally friendly:

EAB elements contains no metal parts: therefore it can be crushed and burned minimising the volume of waste material.

Other features:

The optional indicator is located in a safe place inside the housing. Housing includes mounting holes for a padlock, which allows you to increase the security against theft and vandalism.

Pressure Drop Curves

$\Delta P_{total} = \Delta P_{housing} + \Delta P_{element}$

The recommended level of the initial pressure drop for this filter is max 0.02 bar/2.0kPa (0.29 psi).

EAB10 Housing Only

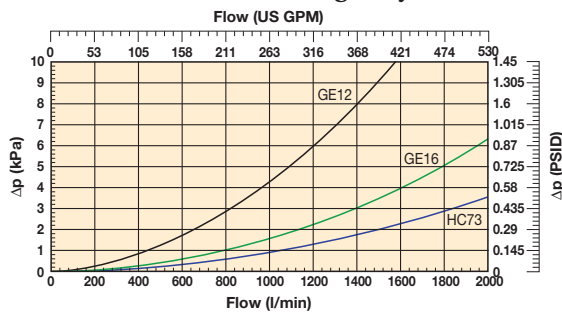

EAB10 Elements

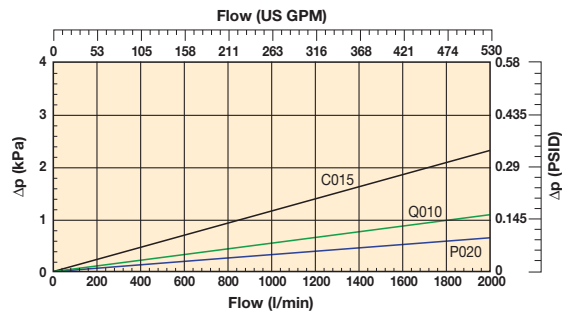

EAB20 Housing Only

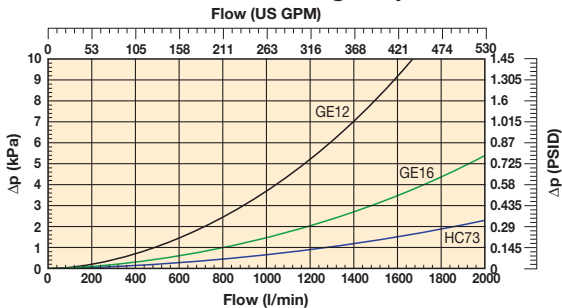

EAB20 Elements

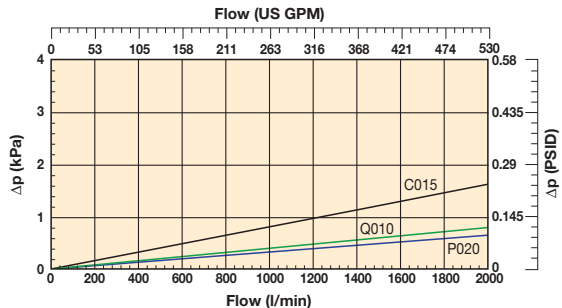

EAB Series

Specifications

EAB10

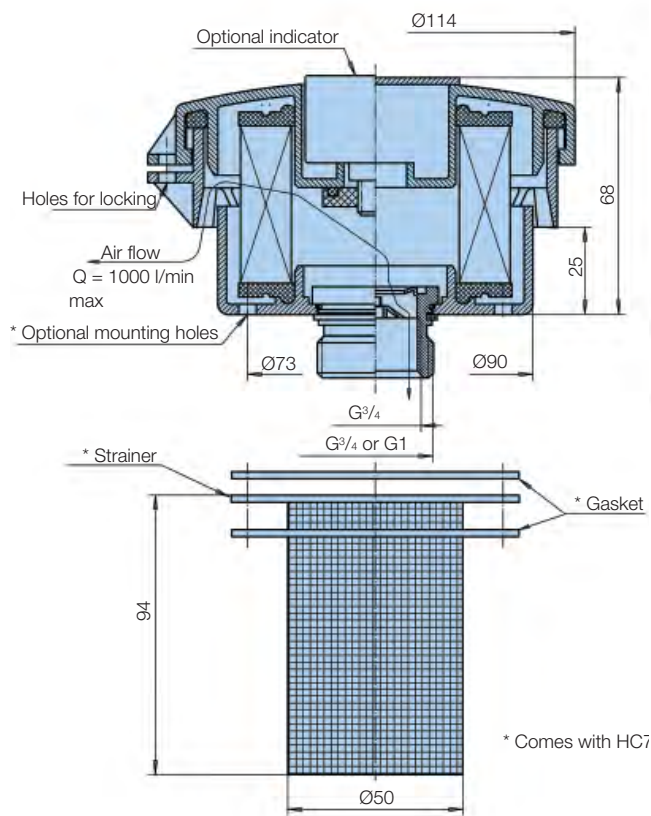

EAB20

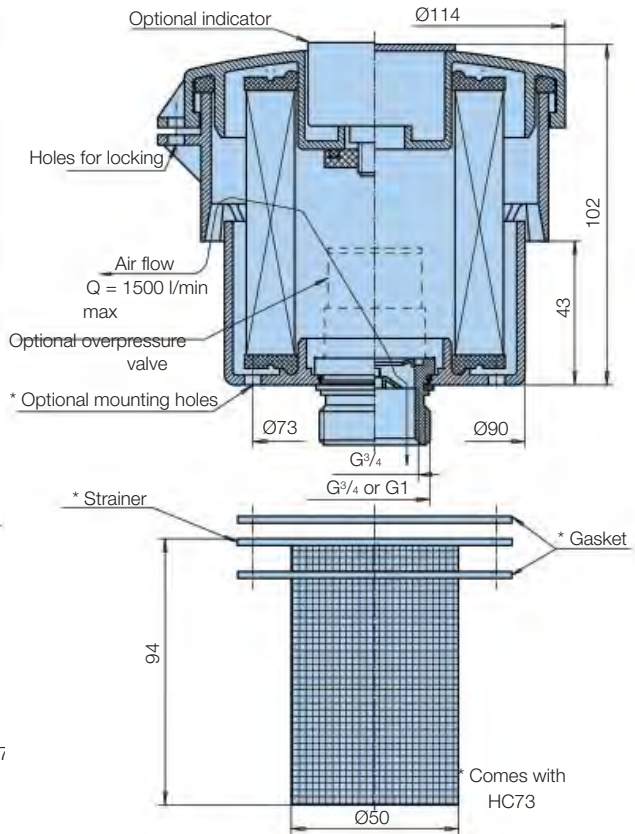

NOTICE!
Air filters are an essential part of the system and the element needs to be replaced regularly.

Mounting	Code
6 mounting holes	HC73
G1 external	GE16
G3/4 external	GE12
G3/4 internal	GS12

6 hole fixing mounting dimensions

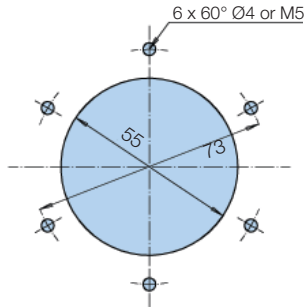

EAB Series

How to Order

Standard products table

Part number	Supersedes	Model	Media	Mounting	Overpressure valve	Indicator	Replacement elements
EAB20P020GE16A	N/A	EAB20	P020	GE16	V2	A	EAC20P020

Product configurator

Product number	Media options		Mounting options		Overpressure valve options		Indicator options	
EAB20	P020	2µ abs polyester	HC73	6 hole fixing		No overpressure valve		No indicator
EAB10	C015	1.5µ abs water resistant	GE12	G ³ / ₄ external thread	V2	0.2 bar	A	Vacuum/pressure gauge
	Q010	1.0µ abs glass fibre	GE16	G1 external thread G ³ / ₄ internal				
			GS12	thread M33 x 2 external				
			ME33	thread				

Replacement elements

Product number	Media options	
EAC20	P020	2µ abs polyester
EAC10	C015	1.5µ abs water resistant
	Q010	1.0µ abs glass fibre

Note 1: Part numbers featured with bold highlighted codes will ensure a 'standard' product selection.

Note 2: For alternative part number options, consult Parker Filtration.

ABL Series

Reservoir Equipment

Typical Applications

The Parker Filtration ABL-2 Series Air Filters.

- Saw mills
- Agricultural machines
- Articulated dump trucks
- Forestry equipment
- Wheeled loaders
- Lubricating systems
- Excavators
- Industrial power units
- Mobile cranes



Technical Data

Assembly:

Tank top mounted.

Connections:

Threads G1¹/₄ (ISO 228), 1¹/₂" (UN-16-2B).

Seal material:

Seals integrated in LEIF[®] element.

Operating temperature range:

-20°C (-4F), +80°C (176F)

Filtration media:

3 micron.

Flow fatigue characteristics:

Filter media is supported so that the optimal fatigue life is achieved.

Vacuum indicator:

ABL-2 0.04 bar. Visual with latch out memory.

Breather housing:

High impact strength composite.

Filter element:

LEIF[®] element.

Options:

- Adaptor with filter connection.
- Single adaptor.
- Breather with integrated pressure relieve valve for pressurised tank on request only.

LEIF[®] elements can be used for hydraulic fluids only. For other fluids contact Parker Filtration.

Pressure Drop Curves

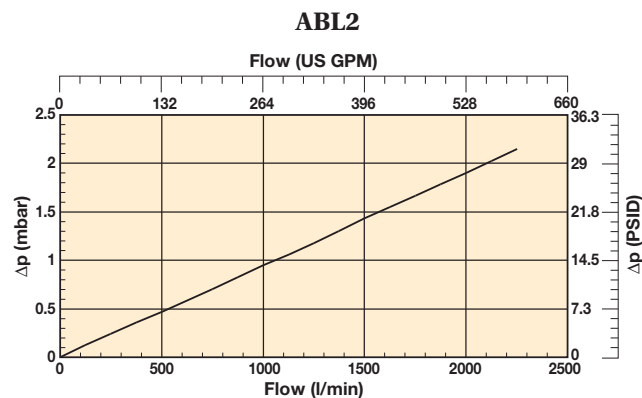

ABL Series

Specifications

ABL-2

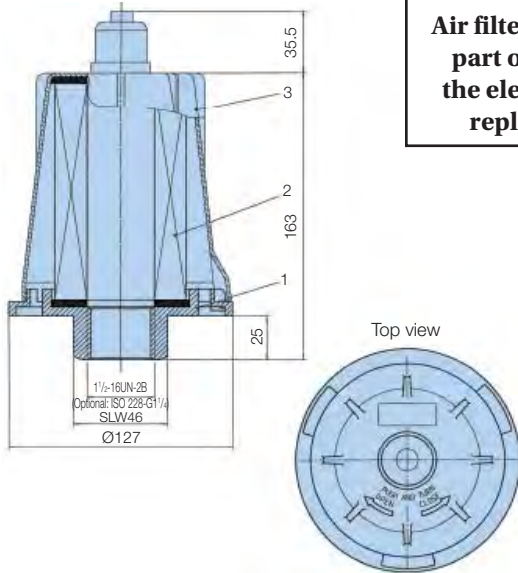

NOTICE!
Air filters are an essential part of the system and the element needs to be replaced regularly.

Extensions and filling mounting adaptors

Adaptor single

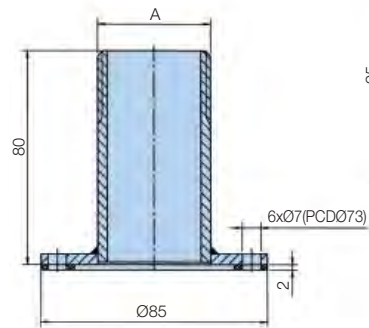

Adaptor with filler connection

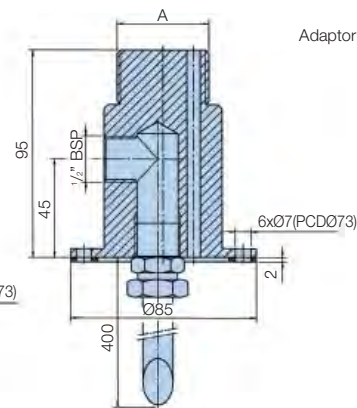

ABL Series

How to Order

Standard products table

Part number	Supersedes	Replacement elements
ABL2G114QXWL13V	ABL2-G1¼-QXWL-1-3-V	QXWL13
ABL2U112QXWL13V	ABL2-U1½-QXWL-1-3-V	QXWL13
ADAPTORABLG114FP	ADAPTOR-ABL-G1¼-FP	-

Product configurator

Product number		Mounting options		Filtration (3µm)		Indicators		Options	
		S11U							
ABL2	2000 l/min		1½ UN-16-2B	QXWL13	ABL2 Only	V	Visual	SNG	Vacuum/Pressure Gauge
								FP	Adaptor With Filler Connection

Product configurator

Product number	Mounting options		Options	
Adaptor ABL	G114	ISO 228 - G1¼ (BSP)	SNG	Single Adaptor
	U112	1½ UN-16-2B	FP	Adaptor With Filler Connection

Replacement elements

Part number	Supersedes	Description
QXWL13	QXWL1-3	3µ

Note 1: Part numbers featured with bold highlighted codes will ensure a 'standard' product selection.

Note 2: Alternate displayed part number selection will require you to contact Parker Filtration for availability.

AB Series

Reservoir Equipment

AB Series - Reservoir Breathers

- High Efficiency Air Breather
- Indicator Notes Replacement Condition



Air Breather With Memory Indicator



Flow Rate Curves

- Determine maximum exchange flow of reservoir in GPM.
- Divide GPM by 7.4 to get SCFM.
- Select Air Filtration Required (in Microns). (Air filtration level should be the same or finer than the filtration level of your Hydraulic system.)
- Select proper can size from the graph below. (Initial clean pressure drop should not exceed 6 inches of water.)

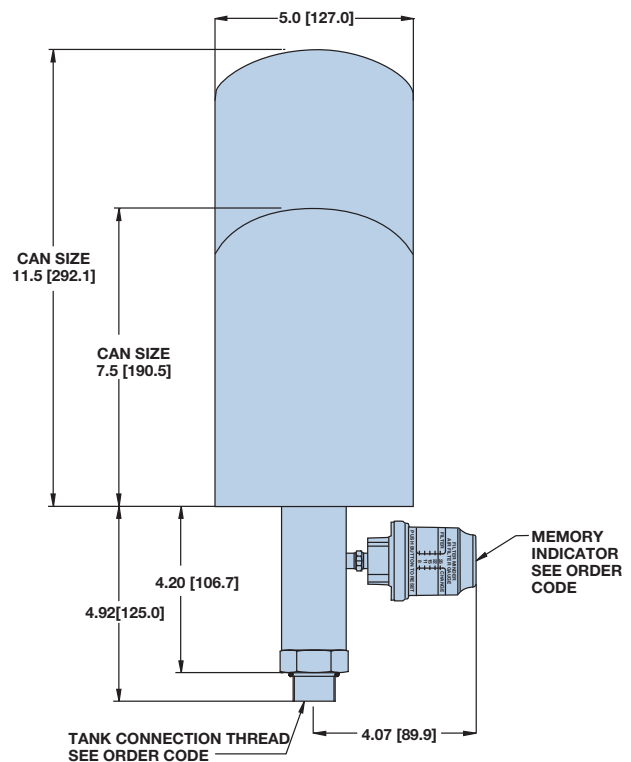
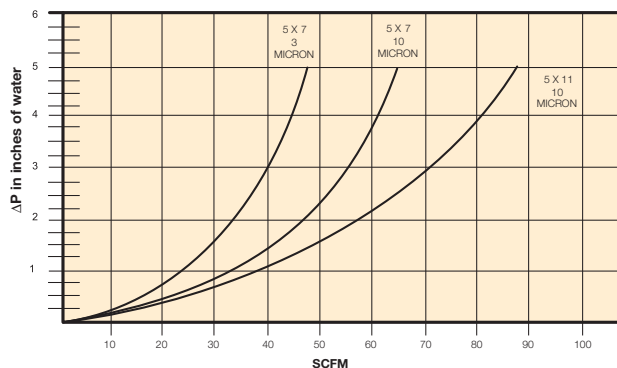

AB Series

How to Order

Select the desired symbol (in the correct position) to construct a model code.

Example:

BOX 1	BOX 2	BOX 3	BOX 4	BOX 5	BOX 6	BOX 7
		AB	3	ST16	10	MI

BOX 1: Division Code	
Symbol	Description
None	Leave Blank
Note: Used for specific automotive program identification.	

BOX 2: Plant Code	
Symbol	Description
None	Leave Blank
Note: Used for specific automotive plant location.	

BOX 3: Configuration	
Symbol	Description
AB	Air Breather

BOX 4: Can Size	
Symbol	Description
2	3.5" x 5"
3	5" x 7.5"
4	5" x 11"

BOX 5: Tank Connection Thread	
Symbol	Description
P12	3/4" NPT male *Only available with option -2, Box 4
G12	G 3/4"-14 BSPP thread (ISO 1179-1) *Only available with option -2, Box 4
ST16	1 5/16-12 SAE straight thd. (ISO 11926) *Only available with options -3 & -4, Box 4
M27	M27 x 2 metric thread (ISO 6149)
G16	G 1"-11 BSPP thread (ISO 1179-1) *Only available with options -3 & -4, Box 4

BOX 6: Air Filtration	
Symbol	Description
3*	3 micron Cellulose
10	10 micron Cellulose
*Note: 3 micron Cellulose is not available in can size 4 (5" x 11").	

BOX 7: Indicator	
Symbol	Description
MI	Memory Indicator
Note: Not available for option -2, Box 4.	

Replacement Breather Cans

Media	Designate Size 3.5" x 5"	Designate Size 5" x 7.5"	Designate Size 5" x 11"
3 Micron	926543	926541	NA
5 Micron	921999	926169	927136



LaserCM Portable Particle Counter

Fluid Condition Monitoring



ENGINEERING YOUR SUCCESS.

LaserCM

Portable Particle Counter

Typical Applications

- Construction machinery
- Industrial plant
- Hydraulic equipment & system manufacturers
- Research & testing institutes
- Offshore & power generation
- Marine
- Military equipment applications



Parker LaserCM Portable Particle Counter.

With 15 years experience in manufacturing the world's best selling 'white light' portable particle counter - CM20, the progression to the LaserCM with its opto-mechanical, continuous wave single point source laser (SPSL) is both a natural and customer driven development.

Features & Benefits

Test time: 2 minutes

Particle counts:

>2 μ , >5 μ , >15 μ , >25 μ , >50 μ and >100 μ microns

>4 μ , >6 μ , >14 μ , >21 μ , >38 μ and >70 μ microns(c)

International codes:

ISO 7-22, NAS 0-12, SAE 0-12

Data retrieval:

Memory access gives test search facility

Max. working pressure:

420 bar (100 USgpm)

Max. flow rate:

400 I/min (6000 psi) when used with system 20 Sensors. Higher with single point sampler (consult Parker)

Working conditions:

LaserCM will operate with the system working normally

Computer compatibility:

Interface via RS232 connection @ 9600 baud rate.

- Special 'diagnostics' are incorporated into the LaserCM microprocessor control to ensure effective testing.
- Routine contamination monitoring of oil systems with LaserCM saves time and saves money.
- Contamination monitoring is now possible while machinery is working - LaserCM saves on production downtime.
- Data entry allows individual equipment test log details to be recorded.
- Data retrieval of test results from memory via hand set display.
- Automatic test cycle logging of up to 300 tests can be selected via hand set display.
- Totally portable, can be used as easily in the field as in the laboratory.
- Automatic calibration reminder.
- Instant, accurate results achieved with a 2 minute test cycle.
- Data entry allows individual equipment footprint record.
- Data graphing selectable via the integral printer.
- Auto 300-test cycle logging via LCD handset input.
- RS232 serial port computer interface.
- Limit level output to control peripheral equipment such as off-line filtration via internal relay limit switches.
- Auto-testing allows for the conducting of automatic sequencing tests on flushing systems for example.
- Optional bar code swipe wand to allow handset data loading.
- Worldwide service and technical support.
- Re-calibration - Annual certification by an approved Parker Service Center.

LaserCM

Specifications

Automatic Particle Counters (APC's), have been widely used for many years in condition monitoring of hydraulic fluids. However, it is only recently that APC's have become flexible enough to enable the instruments to be taken out of the laboratory and used on-line in order to obtain the most credible form of results.

Unusually, the move from fixed laboratory use, to portable field use has not been at the expense of accuracy or user flexibility, but has actually enabled the instruments to be used over a wider range of applications and situations.

The most common monitoring technique used in APC's is that of light obscuration or light blockage. Here, a focused light source is projected through a moving column of oil, (in which the contaminants being measured are contained), causing an image of the contaminant to be projected on to a photo diode cell, (changing light intensity to an electrical output).

The electrical output of the photo diode cell will vary in accordance with the size of the particles contained in the column of oil; the larger the particle, the bigger the change in the photo diode electrical output.

On-line APC's must be able to test the oil sample at whatever cleanliness it is delivered to the machine. Parker therefore had to develop technology to ensure the on-line APC was able to test a sample without the conventional laboratory technique which requires dilution - a practice

that would have been simply impossible with a portable unit.

By careful design and window sizing, gravimetric levels as high as 310mg of dirt per litre, (equivalent to up to 4 million particles >5 micron per 100 ml), can be achieved without making the instrument susceptible to counter saturation.

These high saturation point on-line APC's, whilst losing none of the accuracy of their laboratory counterparts, enable particle counting to be carried out quickly and accurately.

Core technology that proves itself in LaserCM

The LaserCM portable particle counter features microprocessor controlled optical scanning for accurate contaminant measurement with a calibration range from ISO 7 to ISO 22 (NAS 0-12) with no counter saturation.

How does LaserCM work?

- The particles are measured by a photo diode that converts light intensity to a voltage output which is recorded against time.
- As the particle moves across the window the amount of light lost is proportional to the size of the particle. This reduction in voltage is measured and recorded.
- This "voltage" lost relates directly to the area of the particle measured, is changed into a "positive" voltage and then in turn changed into a capacitance value.
- This value is counted and stored in the LaserCM computer in one of 6 channels, >2, >5, >15, >25, >50 and >100 μ according to particle size.
- Readouts are displayed on the hand-held LCD in the accepted ISO and NAS standards ready for hard copy printing or RS232 computer download.
- The on-board computer allows storage of up to 300 test results.



A focused light source is projected through a moving column of oil.

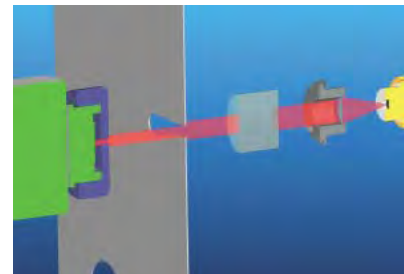

Laser Optical Sensing

LaserCM

Specifications

Description	LaserCM (LCM20.2021)	LaserCM (LCM20.2061)
Lexan, structural foam and ABS case	•	•
ABS handheld display	•	•
Mechanical composition – Brass, plated steel, stainless steel and aluminum	•	•
Fluorocarbon seals	•	•
Perfluoroelastomer seals	•	•
Nylon hoses (kevlar braided microbore)	•	•
Stainless steel armoured hose ends	•	•
1.2m (4ft) fluid connection hose	•	•
System 20 sensors. Higher with single point sampler	•	•
Rechargeable battery pack	•	•
12Vdc power supply	•	•
Fast blow fuse	•	•
Unique optical scanning system	•	•
Bonded glass optical window enclosed in SS plate	•	•
Micron channels analysis (2µ,5µ,15µ,25µ,50µ & 100µ)	•	•
Analysis range ISO 7 to 22 incl. (NAS 0 to 12)	•	•
32 character dot matrix LCD. Alpha numeric keypad	•	•
Data retrieval	•	•
Calibration to ISO standards*	•	•
Viscosity range 2 to 100 cSt. 500 cSt.with SPS	•	•
Operating temp.+5 to +80°C (+41 to +176°C)	•	•
Ambient temp.+5 to +40°C (+41 to +104°C)	•	•
2 minute test completion time	•	•
Memory store – 300 test memory	•	•
12Vdc regulated power supply input	•	•
Battery operated 6 x 1.5 D cells	•	•
Phosphate Ester group compatibility	•	•
Mineral oil & petroleum based fluid compatibility	•	•
Up to 420 bar (6000 psi)	•	•
Integral 16 column printer	•	•
RS232 computer interface	•	•
Astra board case weight – Kg (lbs)	5 (11lbs)	5 (11lbs)
Unit weight – Kg (lbs)	8 (17.6lbs)	8 (17.6lbs)
DATUM software and cable link pack	•	•
Weather protector cover	•	•
CE certified	•	•
Auto logging	•	•

*Note: In compliance with international standards, all Parker portable particle counters can meet the ISO Medium test dust standards. The LaserCM's, in addition to the complete range of Condition Monitoring products, are capable of achieving certification to ISO 4406:1999 and with traceability to ISO 11171 for SRM 2806, via ISO 11943.

Dimensions in mm (ins)

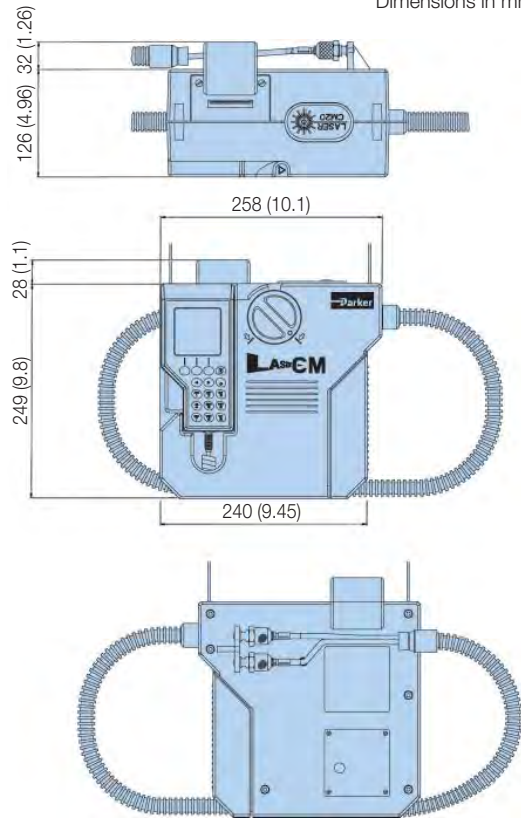

Commissioning Kit

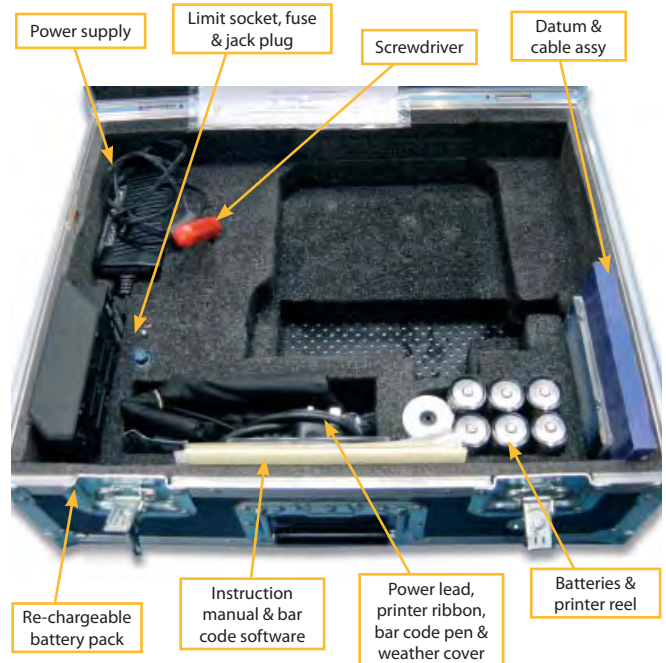

LaserCM

Operation



Operating the Parker LaserCM is as simple as pressing the start button and turning the dial. The test procedure is automatic and in the case of the LaserCM takes no more than 2 minutes to complete.

LaserCM makes the difference in industry

Fully accredited to BS EN 60825:1992 and IEC 60825-1 (safety of laser products) Standards, accredited to USA Standards and achieving full ISO certification. LaserCM offers users advanced laser technology, a fast, dynamic and on-line 2 minute system test cycle. A LaserCM Aggressive Fluids model is also available, suitable for monitoring corrosive fluids such as phosphate ester based lubricants used in commercial aviation.

MTD calibration

Laser CM20 MTD Calibration variants are certified via a primary ISO 11171 calibrated automatic particle counter. All MTD Laser CM20's achieve ISO 4406:1999 criteria, via ISO 11943.

Understanding MTD

ACFTD (Air Cleaner Fine Test Dust) was formatted in the 1960's, but is no longer being produced. The obsolescence of this dust has led to the adoption of a new dust MTD.

MTD (Medium Test Dust) having a particle size distribution close to ACFTD was selected as a replacement. However, MTD produced results somewhat different to ACFTD, so the NIST (National Institute of Standards & Technology) undertook a project to certify the particle size distribution of ISO MTD.

The result was particle sizes below 10µm were greater than previously measured.

Particles sizes reported based on NIST would be represented as µm (c), with "c" referring to "certified". Therefore the CM20 reported sizes are as follows:

ACFTD MTD

2µ	4µ (c)
5µ	6µ (c)
15µ	14µ (c)
25µ	21µ (c)
50µ	38µ (c)
100µ	70µ (c)

MTD offers true traceability, improved particle size accuracy and better batch to batch reproduction.



LaserCM

Portable Particle Counter

Why On-Site Fluid Contamination Monitoring

- Certification of fluid cleanliness levels.
- Early warning instrument to help prevent catastrophic failure in critical systems.
- Immediate results with laboratory accuracy.
- To comply with customer cleanliness requirements and specifications.
- New equipment warranty compliance.
- New oil cleanliness testing.



Datum Data Management



Datum, dedicated software, provides the link between a Laser CM20, System 20 EM20 or the H2Oil - Water in Oil and your computer management system.

Features:

- Windows based, Icon driven program
- Full graphic output
- Tables/results download
- Trend analysis and predictive maintenance
- Auto test communication allows Datum to control particle counter testing and water in oil monitoring
- Certification creator using downloaded data
- Customer customized fields

Laser CM Test	
ON LINE TEST	
TEST NUMBER 022	
Date	D M Y
Time	04-03-06
NAS CLASS:	15-52
	7
Count / 100ml	
4/6µ (c)	789157
6/14µ (c)	31250
NAS CLASS	7
14/21µ (c)	250
NAS CLASS	3
21/38µ (c)	50
NAS CLASS	3
38/70µ (c)	14
NAS CLASS	4
>70µ (c)	0
NAS CLASS	0
NOTES	

Laser CM Test	
ON LINE TEST	
TEST NUMBER 022	
Date	D M Y
Time	04-03-06
ISO:	15-52
	20/15/09
Count / 100ml	
>4µ (c)	820721
>6µ (c)	31564
>14µ (c)	314
>21µ (c)	64
>38µ (c)	14
>70µ (c)	0
NOTES	

ISO 4406 - 1996
(MTD calibration comes under ISO 4406 - 1999 revised standards)

Correlation to NAS 1638

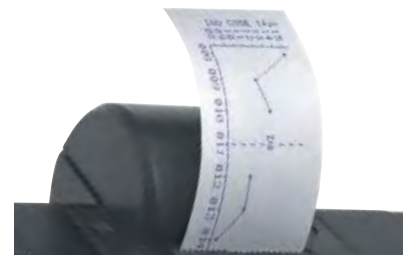

16-column printer for hard copy data. A feature of the LaserCM is the on-board printout data graphing option developed to support predictive maintenance procedures.

LaserCM

Portable Particle Counter

Introducing the new LCM 'Classic'

There is a new addition to the proven range – the LCM 'Classic'. Only available from Parker, the 'Classic' retains all the technology that made the LaserCM one of the most accurate, reliable and popular portable particle counters available.

Our design engineers have re-configured the LaserCM specification in a way that has reduced our manufacturing costs. These savings have been passed onto LCM 'Classic' customers.

How have we done this?

First we talked to our existing customers and then to the engineers and maintenance operatives to find out the features that make the LaserCM a unique predictive maintenance instrument.

Then, we removed peripheral items such as the aluminum case and all the accessories, so a customer receives the monitor, with a CD user guide, professionally and securely boxed. One thing that has not altered is laser accuracy and laser reliability. Our in-house software engineers have re-configured the EPROM, removing Data programming, User ID, Automatic Testing, Data retrieval, Alarm level settings, the barcode pen and Graph printing functions to reduce costs still further without in any way reducing the efficiency of the monitor. The LCM 'Classic' is an instrument to be proud of.



Ordering Information (LaserCM and 'Classic' LaserCM)

Standard products table

Part number	Supersedes	Description
LCM202022	N/A	MTD calibrated
LCM202026	N/A	Classic unit - MTD calibrated
B84702	B.84.702	Printer paper (5 rolls)
P843702	N/A	Printer ribbon
B84729	B.84.729	12Vdc power supply
B84609	B.84.609	Re-chargeable battery pack
P849613	N/A	Weather protector cover
B84779	B.84.779	Datum software pack
B84708	B.84.708	Cable and adaptor

Note 1: Part numbers featured with bold highlighted codes will ensure a 'standard' product selection.

Note 2: Alternate displayed part number selection will require you to contact Parker Filtration for availability.

Product configurator

Model	Fluid type		Options	
LCM2020	2	Hydraulic mineral	1	ACFTD calibrated
LCM2020	6	Skydrol	2	MTD calibrated
			3	ACFTD calibrated + bar code pen
			4	MTD calibrated + bar code pen
			5	Classic unit - ACFTD calibrated
			6	Classic unit - MTD calibrated

Note 1: Part numbers featured with bold highlighted codes will ensure a 'standard' product selection.

Note 2: Alternate displayed part number selection will require you to contact Parker Filtration for availability.



SPS Single Point Sampler

Fluid Condition Monitoring



ENGINEERING YOUR SUCCESS.

SPS Single Point Sampler

Features & Benefits

The Single Point Sampler provides a means to connect a CM20 or H2Oil to a single pressure test point and balance the differential pressure across the system, to provide a controlled flow of oil into the monitor and away into a waste oil receptacle.

- Lightweight, compact and easy to use design
- Fingertip operated control valve even at high pressures
- 420 bar (6000 psi) rated
- Facilitates testing from large diameter pipes
- Capability to test up to 500cSt (106 SUS) viscosity oils (pressure permitting)
- Pressure compensated flow control mechanism
- Possible to control the valve with the same level of accuracy whether the device is operating at high or low pressure
- Capable of allowing a flow rate

in excess of 10ml/min when operating at any viscosity within the product specification

- Suitable for fluid temperatures from +5°C to +80°C (+41°F to +176°F)
- High quality polished finish. (stainless steel/ aircraft grade aluminum)
- Capable of working with a CM20 or H2Oil connected into a system via the standard one meter extension hose kit
- Suitable for use with mineral and biodegradable oils, petroleum based and phosphate ester fluids
- Phosphate ester version utilises the $\frac{5}{8}$ " BSF HSP style fitting
- Designed so that it meets the lowest possible level of magnetic permeability
- Supplied with accessories kit
- It will maintain the set flow

rate between upper and lower limits within a 100 bar (1450 psi) inline pressure change

- Clear product identification to ensure that it is connected correctly. (i.e. downstream of the CM20 or H2Oil)



Connection Instructions

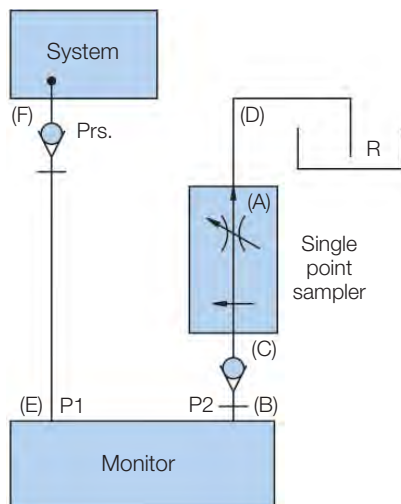

1. Ensure valve is closed (A).
2. Connect P2 on monitor (B) to P2 on Single Point Sampler (SPS) (C).
3. Connect drain line on SPS (D).
4. Connect P1 of monitor (E) to the system (F).
5. The SPS is ready to operate.
6. Open valve (A) slowly until the oil flows continuously from the drainline (D).
7. Switch on monitor and begin testing.

LCM20 Only

Carry out flow test as shown in the manual. If test is showing below Δt 3.6°C (38°F) then carry out test as normal. If, however, test is above Δt 3.6°C (38°F) then increase oil flow by turning valve (A) counterclockwise and then carry out flow test. Do this until Δt is below 3.6°C (38°F) and carry out test as normal once this is achieved.

WARNING! Ensure that SPS valve is closed and monitor is connected to the SPS BEFORE connection to system.

SPS Single Point Sampler

Specifications

Specification

Fluid compatibility:

Mineral oil and petroleum based fluids (standard version).

Aggressive fluid (dual seal version) for other fluids consult Parker Hannifin.

Seals:

Fluorocarbon or Perfluoroelastomer.

Maximum working pressure:

420 bar (6000 psi).

Weight:

500 grams (18 oz) max. (Not including hoses).

Packaging standard:

Cardboard carton (military usage - plastic carry case).

Unit size:

45mm dia x 123mm long. (1.77 dia x 4.84 long)

System connection:

Standard - minimess M16 (G¹/₄" BSP) with cap,

Aggressive - 5/8" BSF HSP.

Operating temp range:

+5°C to +80°C (+41°F to +176°F).

Storage temperature range:

-26°C to +80°C (-15°F to +176°F).

Construction:

Body: Aluminum BS 1470

- pressurized end stainless steel.

Finish: Anodized blue

(standard version). Anodized

red (dual seal version).

Ordering Information

Standard products table

Product number	Supersedes	Description
SPS2021	N/A	Mineral single point sampler
SPS2061	N/A	Aggressive single point sampler
B84784	B.84.784	Mineral or aggressive bottle assembly
B84224	B.84.224	Mineral oil extension hose/coupling
B84225	B.84.225	Aggressive oil extension hose/coupling
B84788	B.84.788	Mineral oil waste hose
B84787	B.84.787	Aggressive oil waste hose

Note 1: Part numbers featured with bold highlighted codes will ensure a 'standard' product selection.

Note 2: Alternate displayed part number selection will require you to contact Parker Filtration for availability.

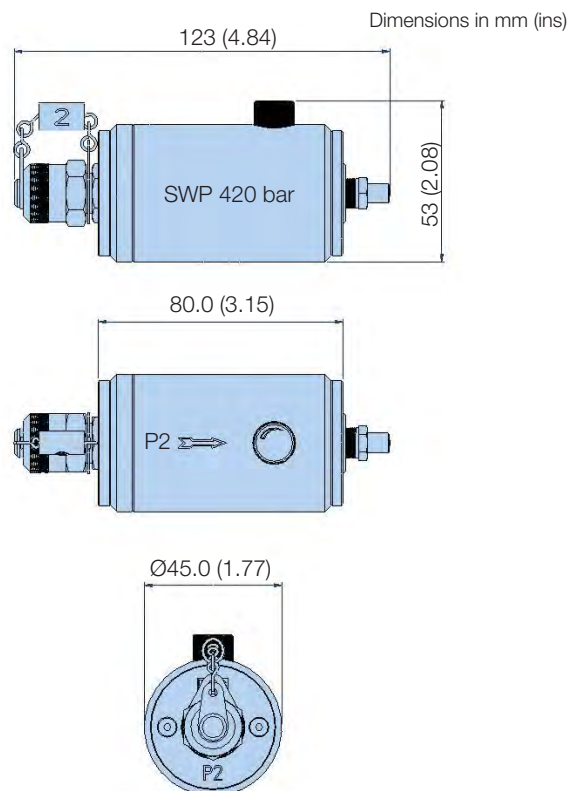

System 20

Inline Sensors & Monitors/Fluid Condition Monitoring



Specification: Sensors

Construction:

Machined steel body. Electroless nickel coating to minimum depth of 40 microns
Brass/stainless steel internal components

Flow capacities:

All suitable for use with oil, water and water/oil emulsion
Size 0 – 6-25 l/min (1.58-6.60 US GPM)
Size 1 – 20-100 l/min (5.28-26.4 US GPM)
Size 2 – 80-380 l/min (21.1-100 US GPM)

Max. working pressure:

420 bar (6000psi)

Capability:

Reverse flow

Pressure drop:

At max. rated flow, ΔP is 1.1 bar (16 psi) (mineral oil fluid at 30 cSt 140 SSU).

Ports:

Size 0 – G3/8
Size 1 – G3/4 (SAE threads also available)
Size 2 – G1 1/4

Repeatability:

$\pm 1\%$ FSD

Accuracy:

Flow $\pm 2.5\%$ full scale deflection

Weight:

Size 0 – 0.5kg (1.2lbs)
Size 1 – 3.5kg (8.4lbs)
Size 2 – 4.4kg (9lbs)

Aggressive Fluid Applications:

EPDM internal/external o-rings and seals

Installation Details

Size 0 Sensor

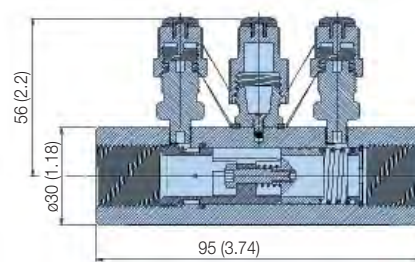

Dimensions in mm (ins)



G3/8

Size 1 Sensor

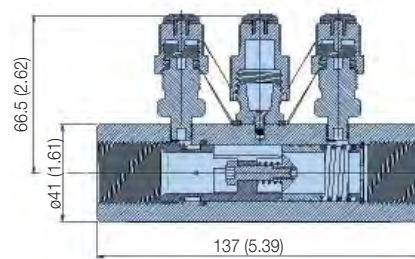

G3/4

Size 2 Sensor

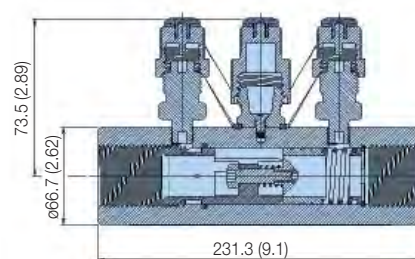

G1 1/4

Ordering Information

Standard products table

Product number	Supersedes	Size	Flow range l/min (USgpm)	Fluid type	Port threads
STI0144100	STI.0144.100	0	6-25 (1.58-6.60)	Mineral	3/8
STI1144100	STI.1144.100	1	20-100 (5.28-26.4)	Mineral	3/4
STI2144100	STI.2144.100	2	80-380 (21.1-100)	Mineral	1 1/4
STI0148100	STI.0148.100	0	6-25 (1.58-6.60)	Aggressive	3/8
STI1148100	STI.1148.100	1	20-100 (5.28-26.4)	Aggressive	3/4
STI2148100	STI.2148.100	2	80-380 (21.1-100)	Aggressive	1 1/4

Note 1: Part numbers featured with bold highlighted codes will ensure a 'standard' product selection.

Note 2: Alternate displayed part number selection will require you to contact Parker Filtration for availability.

Note 3: Mobile Sensors are also available - Contact Parker



Icount PD

Online Particle Detector



ENGINEERING YOUR SUCCESS.

Icount PD

The Icount Particle Detector from Parker represents the most up-to-date technology in solid particle detection.

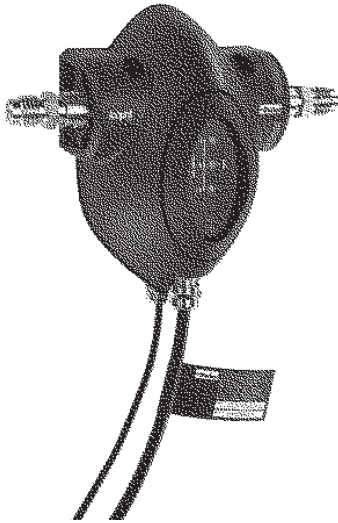

The design dynamics, attention to detail, and small size of the permanently mounted, on-line particle detector brings a truly innovative product to all industry.

The laser based, leading-edge technology is a cost effective market solution to fluid management and contamination control.

Features and benefits of the Icount PD include:

- Independent monitoring of system contamination trends.
- Early warning LED or digital display indicators for Low, Medium and High contamination levels.
- Moisture % RH LED indicator (optional).
- Cost effective solution in prolonging fluid life and reducing machine downtime.
- Visual indicators with power and alarm output warnings.
- Continuous performance for dependable analysis.
- Hydraulic, phosphate ester & fuel fluid compatible construction.
- Self diagnostic software.
- Fully PC/PLC integration technology such as:
RS232 and 0-5 Volt, 4-20mA.

Typical Applications

Mobile Equipment

- Earth Moving Machinery
- Harvesting
- Forestry
- Agriculture

Industrial Equipment

- Production Plants
- Fluid Transfers
- Pulp & Paper
- Refineries

Power Generation

- Wind Turbines
- Gearboxes
- Lubrication Systems

Maintenance

- Test Rigs
- Flushing Stands



Icount PD

Features and Benefits

Diagnostic self check start-up time	5 seconds
Measurement period	5 to 180 seconds
Reporting interval through RS232	0 to 3600 seconds
Digital LED display update time	Every second
Limit relay output	Changes occur +/- 1 ISO code at set limit (Hysteresis ON) or customer set (Hysteresis OFF)
4-20mA output signal	Continuous
Principle of operation	Laser diode optical detection of actual particulates
Reporting codes	ISO 7 – 21, NAS 0 – 12, (AS 00 – 12 contact Parker) Icount will also report less than ISO 7, subject to the statistical uncertainty defined in ISO4406:1999, which is shown in the RS232, reporting results as appropriate e.g “>6”
Calibration	By recognized on-line methods, confirmed by the relevant International Standards Organization procedures
Calibration recommendation	12 months
Performance	+/- 1 ISO Code (dependant on stability of flow)
Reproducibility / Repeatability	Better than 1 ISO Code
Power requirement	Regulated 9 to 40Vdc
Maximum current draw	150mA
Hydraulic connection	M16 x 2 hydraulic test points (5/8” BSF for aggressive version)
Flow range through the device	40 to 140 ml/min (optimum flow = 60ml/min)
Online flow range via System 20 Inline Sensors	Size 0 = 6 to 25 l/min - (optimum flow = 15 l/min) Size 1 = 24 to 100 l/min - (optimum flow = 70 l/min) Size 2 = 170 to 380 l/min - (optimum flow = 250 l/min)
Required differential pressure across Inline Sensors	5.8 psi (0.4 bar) minimum
Viscosity range	10 to 500 cSt
Temperature	Operating environment: -20°C to +60°C (-4°F to +140°F) Storage: -40°C to +80°C (-40°F to +176°F) Operating fluid: 0°C to +85°C (+32°F to +185°F)
Working pressure	2 to 420 bar (30 to 6,000 PSI)
Moisture sensor calibration	±5% RH (over compensated temperature range of +10°C to +80°C)
Operating humidity range	5% RH to 100% RH
Moisture sensor stability	±0.2% RH typical at 50% RH in one year
Certification	IP66 rated EMC/RFI – EN61000-6-2:2001 EN61000-6-3:2001
Materials	User friendly construction Stainless Steel hydraulic block Viton seals
Dimensions	7.2” x 6.1” x 3.4” (182mm x 155mm x 86mm)
Weight	2.9 lbs. (1.3 kg)

Icount PD

Dimensions / Installation Details

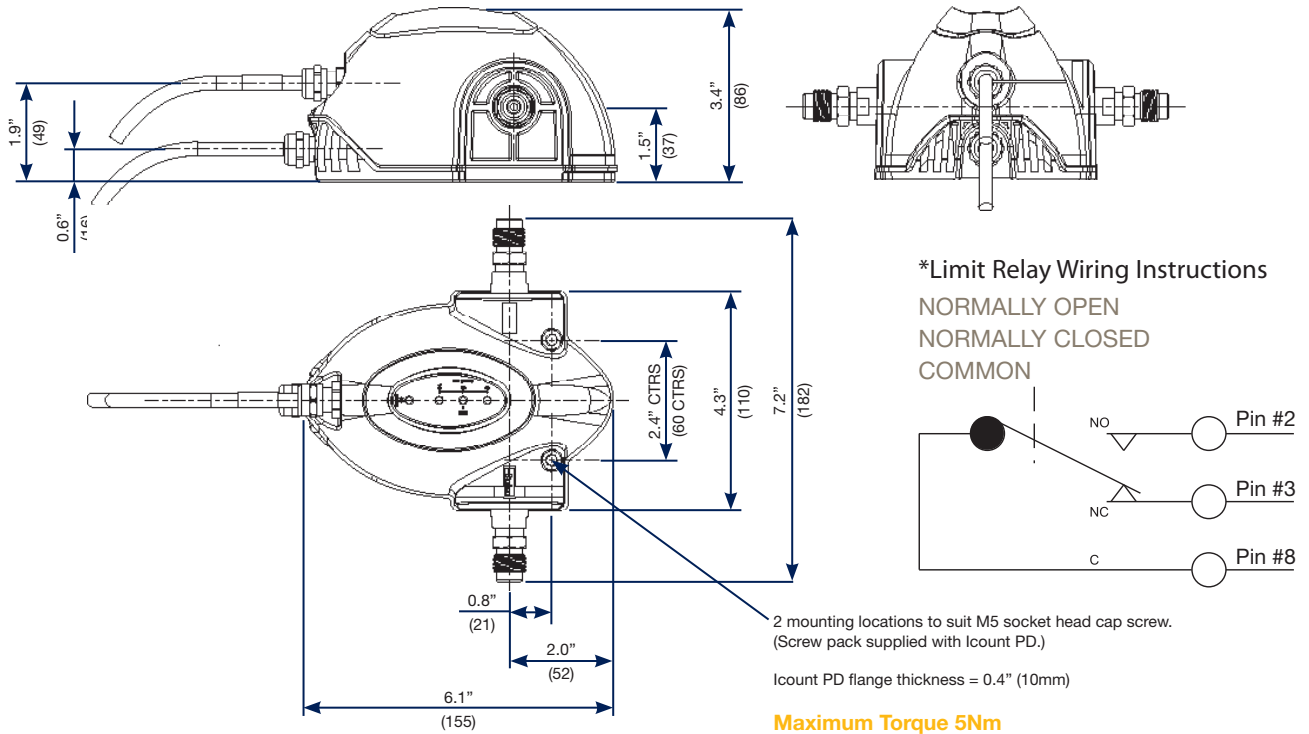

M12 Communication Cable: Wiring Configuration

Pin	4-20mA option connections	0-5V/0-3V option connections
1	NOT USED	NOT USED
2	RS232 Ground (pin 5**)	RS232 Ground (pin 5**)
3	Channel A, ISO 4µm (c)*	Channel A, ISO 4µm (c)*
4	Channel B, ISO 6µm (c)* or NAS (if selected)	Channel B, ISO 6µm (c)* or NAS (if selected)
5	RS232 Receive (Pin 3**)	RS232 Receive (Pin 3**)
6	RS232 Transmit (Pin 2**)	RS232 Transmit (Pin 2**)
7	Moisture sensor channel (if fitted)	Moisture sensor channel (if fitted)
8	Channel C, ISO 14µm (c)*	Channel C, ISO 14µm (c)*

Note: It is the responsibility of the end user to ensure that the cable's braided screen is terminated to a suitable earth bonding point.

* Optional - refer to the Icount PD part number specifier section in the manual.

** A standard USB serial adaptor can be used with the recommended 9-way D-type connector to convert RS232 to USB.

*M12 Limit Relay & Alarm Levels: Wiring Configuration

Pin	Current loop option connections	0-5V/0-3V option connections
1	Product supply 9-40Vdc	Product supply 9-40Vdc
2	4-20mA supply 12-20Vdc	0-5 / 0-3V supply 12-24Vdc
3	Relay (Normally Closed)*** (if fitted)	Relay (Normally Closed)*** (if fitted)
4	Relay (Normally Open)*** (if fitted)	Relay (Normally Open)*** (if fitted)
5	NOT USED	NOT USED
6	NOT USED	0-5 / 0-3V supply 0Vdc
7	Main supply 0Vdc	Product supply 0Vdc
8	Relay (Common)*** (if fitted)	Relay (Common)*** (if fitted)

Note: If the moisture sensor is fitted without either option, then the output is RS232.

Parker recommends that the mating M12 connector cables are screened. These cables are available from Parker through the ordering information section.

*** Optional - refer to ordering information section.

Icount PD

Variable mA output settings

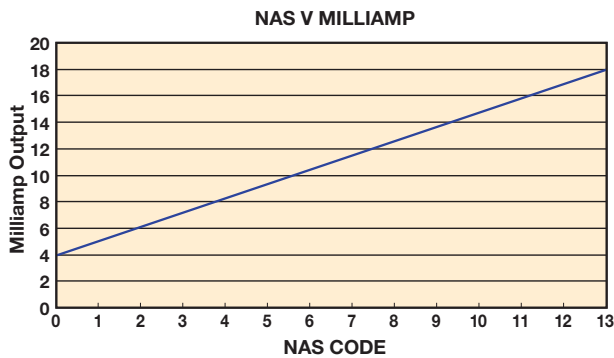
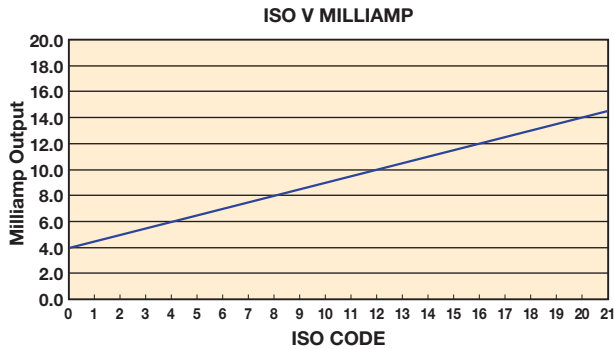

The following table can be used to equate the analogue output to an ISO or NAS Code.

Example: ISO code 12 is equal to 10mA.

mA	ISO
4.0	0
4.5	1
5.0	2
5.5	3
6.0	4
6.5	5
7.0	6
7.5	7
8.0	8
8.5	9
9.0	10
9.5	11
10.0	12
10.5	13
11.0	14
11.5	15
12.0	16
12.5	17
13.0	18
13.5	19
14.0	20
14.5	21
15.0	**
15.5	**
16.0	**
16.5	**
17.0	**
17.5	**
18.0	**
18.5	**
19.0	OVERRANGE
19.5	OVERRANGE
20.0	ERROR

mA	NAS
4	00
5	0
6	1
7	2
8	3
9	4
10	5
11	6
12	7
13	8
14	9
15	10
16	11
17	12
18	**
19	**
20	ERROR

4-20mA output settings

ISO Setting

$\text{mA current} = (\text{ISO Code} / 2) + 4$

eg. $10\text{mA} = (\text{ISO } 12 / 2) + 4$

or

$\text{ISO Code} = (\text{mA current} - 4) * 2$

eg. $\text{ISO } 12 = (10\text{mA} - 4) * 2$

NAS Setting

$\text{mA current} = \text{NAS Code} + 5$

eg. $15\text{mA} = \text{NAS } 10 + 5$

or

$\text{NAS Code} = \text{mA current} - 5$

eg. $\text{NAS } 10 = 15\text{mA} - 5$

Variable voltage output settings

The variable voltage output option has the capability of two different voltage ranges: a 0-5Vdc range as standard, and a user-selectable 0-3Vdc range. The full list of

commands on how to change the voltage output is available from Parker.

The following tables can be used to relate the analog output to an ISO or NAS code.

For example, in a 0-5Vdc range, ISO code 16 is equal to an output of 3.5Vdc. In a 0-3Vdc range, ISO code 8 is equal to an output of 1.0Vdc.

Table relating ISO codes to voltage output

ISO	Err	0	1	2	3	4	5	6	7	8	9	10	11	▶▶
0-5Vdc	<0.2	0.3	0.5	0.7	0.9	1.1	1.3	1.5	1.7	1.9	2.1	2.3	2.5	
0-3Vdc	<0.15	0.2	0.3	0.4	0.5	0.6	0.7	0.8	0.9	1.0	1.1	1.2	1.3	

▶▶

cont.

ISO	12	13	14	15	16	17	18	19	20	21	22	Err
0-5Vdc	2.7	2.9	3.1	3.3	3.5	3.7	3.9	4.1	4.3	4.5	4.7	>4.8
0-3Vdc	1.4	1.5	1.6	1.7	1.8	1.9	2.0	2.1	2.2	2.3	2.4	>2.45

Table relating NAS codes to voltage output

ISO	Err	00	0	1	2	3	4	5	6	7	8	9	10	11	12	Err
0-5Vdc	<0.4	0.6	0.9	1.2	1.5	1.8	2.1	2.4	2.7	3.0	3.3	3.6	3.9	4.2	4.5	>4.6
0-3Vdc	<0.2	N.S.	0.3	0.5	0.7	0.9	1.1	1.3	1.5	1.7	1.9	2.1	2.3	2.5	2.7	>2.8

Icount PD

Display parameters (ISO 4406/NAS 1638)

Digital display indication

The digital display will show the actual measured codes, the channel (μ) size and the user defineable limits. Note that the channel size and limits will alternate between the two.

The moisture sensor reading (%RH) will also be shown - if the moisture sensor option is fitted.

The order of trigger for both of the codes and moisture sensor option is:

- Solid digit(s) = code(s) that are at or below the set point (limit)
- Flashing digit(s) = code(s) that are above the set point (limit)

The display for ISO4406 and NAS1638 are identical. The ISO display is shown below.



LED display indication

The LED display uses 3 sets of LED for the indication of ISO 4406 and NAS1638 code figures. Individual code lights will trigger based on the customer settings.

The order of trigger will be:

- Solid green = one ISO code, or better, below the set point (limit)
- Blinking green = ISO code at the set point (limit)
- Solid red = one ISO code above the set point (limit)
- Blinking red = two ISO codes, or more, above the set point (limit)

Error detection

In the unlikely event of an error occurring, the digital display on the Icount PD will simply display the actual error code only - i.e. ERROR 13 (a full list of error codes is detailed in the Icount PD user manual).

Moisture sensor output settings

The moisture sensor is an option that can be included when specifying the Icount PD. The moisture sensor reports on the saturation levels of the fluid passing through the Icount PD sensing cell. The output is a linear scale, reporting within the range of 5% saturation to 100% saturation.

Saturation	4-20mA	0-3Vdc	0-5Vdc
5%	4.8	0.15	0.25
25%	8	0.75	1.25
50%	12	1.50	2.50
75%	16	2.25	3.75
100%	20	3.00	5.00

Icount PD

Auxilliary Flow Device

The pressure compensated, flow control device (Part Number S840074) has been developed to give the Icount PD user greater flexibility. The flow control device will enable testing where flow ranges are outside the Icount PD specifications (40 - 140 ml/min), or where pipe diameters do not allow the Icount PD to be installed.

The flow control device fits onto the downstream (outlet) side of the Icount PD, connecting through a manifold block, via a self-sealing quick connection test point and is fitted with a differential pressure valve.

This flow control device automatically compensates for pressure and viscosity changes, while maintaining its setting even as the workload changes.

Simply position the valve to match the viscosity of the oil you are testing.

The chart below can be used to determine the valve position:

Valve Position	cSt Range
3	up to 100
3.8	90 - 200
4.2	190 - 320
5	310 - 500

Example:

If the fluid you wish to analyse has a viscosity of 50cSt under normal operating conditions then the control knob on the Flow Control Device should be set to valve position '3'.

The flow device will now automatically control the flow rate through the IcountPD to within its working range of 40-140ml/min.

Note: The flow control device will still operate correctly even with the high pressure side at 200bar and the return back to an open system of 0 bar (DP = 200bar).

Hydraulic Connection Diagram

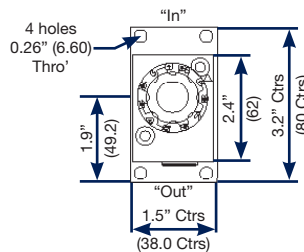
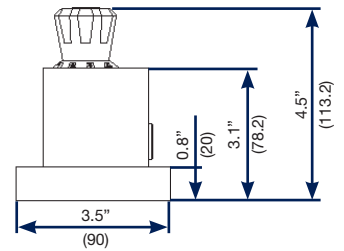
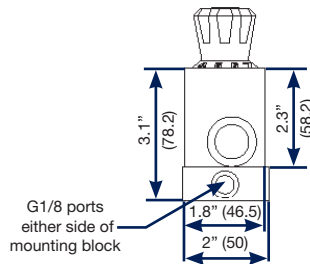
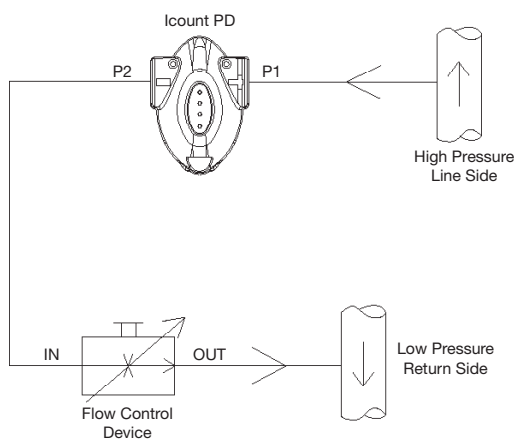

Actuator	Manual flow rate adjustable via control knob
Mounting type	4 off mounting holes to suit M6 screws (not supplied)
Mounting position	Any
Weight	3.7 lb. (1.7 kg)
Fluid temperature	+41°F to +176°F (+5°C to +80°C)
Ambient storage temperature	-4°F to +104°F (-20°C to +40°C)
Viscosity range	20cSt to 500cSt (if lower than 20cSt, contact Parker)
Differential pressure range	5 to 315 bar
Maximum pressure	315 bar
Flow direction	IN to OUT flow control function
Port thread detail	1/8" BSPP (test points not supplied)
Internal seals	Viton

Icount PD

Communication Options

The IcountPD may be configured using the Icount PD Setup Utility. For more direct control of the device using its communications protocol, you may also use the Microsoft Windows® HyperTerminal program (this program is not currently supplied with the Windows Vista™ operating system).

Communication protocol

The communication protocol for the serial communication link is to be used with Microsoft Windows HyperTerminal. The settings are as follows:

Baud rate 9600
 Data bits 8
 Parity None
 Stop bits 1
 Flow control None

The commands used with this product are made up of Set, Read and Start/Stop commands.

- **Set commands allow the value or values of parameters to be set**
- **Read commands allow the value or values of parameters to be read**
- **Start/Stop allows the user to start and stop tests**

All commands are sent in ASCII characters, and the protocol accepts both upper and lower case characters as the examples below:

SDF
 SdF

Note: A full list of commands is detailed in the user manual.

Ordering Information

Key	Fluid Type	Calibration	Display	Limit Relay	Communication	Moisture Sensor	Cable Connector Kit
IPD	1 Mineral	1 ACFTD	2 LED	2 Yes	2 RS232/4-20mA	1 No	10 Deutsch DT series connector
	2 Aggressive	2 MTD	3 LCD		3 RS232/0-5V	2 Yes	30 M12, 8-pin plug connector*
	3 Aviation fuel Hazardous areas	3 AS4059					
	4 Aviation fuel Non Hazardous areas						

Accessories	Part Number	
	Mineral	Aggressive
1 Meter Hose Length	B.84.224	B.84.827
2 Meter Hose Length	B.94.802	B.94.801
5 Meter Hose Length	B.84.730	B.84.828
1/4" BSP Test point	P.653109 (M16)	P.843081 (5/8 BSF)
1/8" BSP Test point	P.653110 (M16)	P.853008 (5/8 BSF)
1/8" NPT Test point	P.653512 (M16)	P.853005 (5/8 BSF)
Single Point Sampler	SPS2021	SPS2026
External Flow Device	S840074	Contact Factory
Power Supply	B.84.829	B.84.829
5 meter, M12, 8-pin plug and socket cable kit*	Contact Factory	Contact Factory

*M12 Cable kit consists of two 5 meter cables to enable all output options (Communications cable and Relay/Power Supply cable)

Parker Hannifin Corporation
Filtration Group
Global Headquarters
 6035 Parkland Boulevard
 Cleveland, OH 44124-4141
 T 216 896 3000, F 216 896 4021
www.parker.com

North America

Compressed Air Treatment
Filtration & Separation/Balston
 242 Neck Road
 Haverhill, MA 01835-0723
 T 978 858 0505, F 978 858 0625
www.parker.com/balston

Filtration & Separation/Finite
 500 Glaspie Street, PO. Box 599
 Oxford, MI 48371-5132
 T 248 628 6400, F 248 628 1850
www.parker.com/finitefilter

Purification, Dehydration and
Filtration Division
 4087 Walden Avenue
 Lancaster, NY 14086
 T 716 685 4040, F 716 685 1010
www.airtek.com
 Sales Office
 5900-B Northwoods Parkway
 Charlotte, NC 28269
 T 704 921 9303, F 704 921 1960
www.domnickhunter.com

Engine Filtration & Water Purification

Racor
 3400 Finch Road, PO Box 3208
 Modesto, CA 95353
 T 209 521 7860, F 209 529 3278
www.parker.com/racor

Racor
 850 North West St., PO Box 6030
 Holly Springs, MS 38635
 T 662 252 2656, F 662 274 2118
www.parker.com/racor

Racor
 302 Parker Drive
 Beaufort, SC 29906
 T 843 846 3200, F 843 846 3230
www.parker.com/racor

Racor -- Village Marine Tec.
 2000 West 135th Street
 Gardena, CA 90249
 T 310 516 9911, F 310 538 3048
www.villagemarine.com

Hydraulic Filtration

Hydraulic Filter
 16810 Fulton County Road #2
 Metamora, OH 43540-9714
 T 419 644 4311, F 419 644 6205
www.parker.com/hydraulicfilter

Process Filtration

Process Advanced Filtration
 2340 Eastman Avenue
 Oxnard, CA 93030
 T 805 604 3400, F 805 604 3401
www.parker.com/processfiltration

Europe

Compressed Air Treatment
domnick hunter Industrial
 Dukesway, Team Valley Trading Estate
 Gateshead, Tyne & Wear
 England NE11 OPZ
 T +44 (0) 191 402 9000,
 F +44 (0) 191 482 6296
www.domnickhunter.com

Hiross Zander
Padova Business Unit
 Strada Zona Industriale 4
 35020 S. Angelo di Piove Padova, Italy
 T +39 049 9712 111, F +39 049 9701 911
www.dh-hiross.com

Hiross Zander
Essen Business Unit
 Zander Aufbereitungstechnik GmbH
 Im Teelbruch 118
 D-45219 Essen, Germany
 T +49 2054 9340, F +49 2054 934164
www.zander.de

Parker Gas Separations
 Oude Kerkstraat 4
 P O Box 258
 4870 AG Etten- Leur, Netherlands
 T +31 76 508 5300, F +31 76 508 5333

Engine Filtration & Water Purification

Racor
 Shaw Cross Business Park
 Churwell Vale Dewsbury,
 WF12 7RD England
 T +44 (0) 1924 487000,
 F +44 (0) 1924 487038
www.parker.com/rfde

Racor Research & Development
 Parker Hannifin GmbH & Co KG
 Inselstrasse 3 - 5
 70327 Stuttgart Germany
 T +49 (0)711 7071 290-0,
 F +49 (0)711 7071 290 -70
www.parker.com/racor

Hydraulic Filtration

Hydraulic Filter
 Stieltjesweg 8, 6827 BV
 P.O. Box 5008 6802 EA
 Arnhem, Holland
 T +31 26 3760376, F +31 26 3643620
www.parker.com/eurofilt

Ujala Operation
 Salmentie 260
 31700 Ujala as Finland
 T +358 20 753 2500, F +358 20 753 2501
www.parker.com/fi

Condition Monitoring Center
 Brunel Way Thetford,
 Norfolk IP 24 1HP England
 T +44 1842 763299, F +44 1842 756300
www.parker.com/cmcc

Process Filtration

domnick hunter Process
 Durham Road, Birtley Co. Durham,
 DH3 2SF England
 T +44 (0) 191 410 5121,
 F +44 (0) 191 410 5312
www.domnickhunter.com

Asia Pacific

Australia
 9 Carrington Road, Castle Hill
 NSW 2154, Australia
 T +61 2 9634 777, F +61 2 9899 6184
www.parker.com/australia

China
 280 YunQiao Road
 JinQiao Export Processing Zone
 Shanghai 101206 China
 T +86 21 5031 2525, F +86 21 5834 3714
www.parker.com/china

India
 Plot EL 26, MIDC, TTC Industrial Area
 Mahape, Navi Mumbai 400 709 India
 T +91 22 5613 7081, 82, 83, 84, 85
 F +91 22 2768 6618 6841
www.parker.com/india

Japan
 626, Totsuka-cho, Totsuka-ku
 Yokohama-shi, 244-0003 Japan
 T +81 45 870 1522, F +81 45 864 5305
www.parker.com/japan

Korea
 1-C Block, Industrial Complex of Jangan,
 615-1, Geumui-Ri Jangan-Myeon,
 Hwaseong-City Gyeonggi-Do, Korea
 T +82 31 359 0771, F +82 31 359 0770
www.parker.com/korea

Singapore
 11, Fourth Chin Bee Road
 Singapore 619 702
 T +65 6887 6300, F +65 6261 4929
www.parker.com/singapore

Thailand
 1023 3rd Floor, TPS Building
 Pattanakam Road, Suanluang,
 Bangkok 10250 Thailand
 T +66 2717 8140, F +66 2717 8148
www.parker.com/thailand

Latin America

Parker Comercio Ltda.
Filtration Division
 Estrada Municipal Joel de Paula
 900 Eugenio de Melo,
 Sao Jose dos Campos
 CEP 12225-390 SP Brazil
 T +55 12 4009 3500, F +55 12 4009 3529
www.parker.com/br

Pan American Division - Miami
 7400 NW 19th Street, Suite A
 Miami, FL 33128
 T 305 470 8800 F 305 470 8808
www.parker.com/panam

Africa

Parker Hannifin Africa Pty Ltd
 Parker Place, 10 Berne Avenue,
 Aeroport Kempton Park,
 1620 South Africa
 T +27 11 9610700, F +27 11 3927213
www.parker.com/au

