



# Flow, Check, Pressure Control, and Sandwich Valves

Industrial Hydraulic Valves

Catalog HY14-2533/US

Supplement to Catalog HY14-2502/US

aerospace  
climate control  
electromechanical  
filtration  
fluid & gas handling  
**hydraulics**  
pneumatics  
process control  
sealing & shielding



ENGINEERING YOUR SUCCESS.

**WARNING – USER RESPONSIBILITY**

FAILURE OR IMPROPER SELECTION OR IMPROPER USE OF THE PRODUCTS DESCRIBED HEREIN OR RELATED ITEMS CAN CAUSE DEATH, PERSONAL INJURY AND PROPERTY DAMAGE.

- This document and other information from Parker-Hannifin Corporation, its subsidiaries and authorized distributors provide product or system options for further investigation by users having technical expertise.
- The user, through its own analysis and testing, is solely responsible for making the final selection of the system and components and assuring that all performance, endurance, maintenance, safety and warning requirements of the application are met. The user must analyze all aspects of the application, follow applicable industry standards, and follow the information concerning the product in the current product catalog and in any other materials provided from Parker or its subsidiaries or authorized distributors.
- To the extent that Parker or its subsidiaries or authorized distributors provide component or system options based upon data or specifications provided by the user, the user is responsible for determining that such data and specifications are suitable and sufficient for all applications and reasonably foreseeable uses of the components or systems.

**OFFER OF SALE**

The items described in this document are hereby offered for sale by Parker-Hannifin Corporation, its subsidiaries or its authorized distributors. This offer and its acceptance are governed by the provisions stated in the detailed "Offer of Sale" elsewhere in this document or available at [www.parker.com/hydraulicvalve](http://www.parker.com/hydraulicvalve).

**SAFETY GUIDE**

For safety information, see Safety Guide SG HY14-1000 at [www.parker.com/safety](http://www.parker.com/safety) or call 1-800-CParker.

© Copyright 2008, Parker Hannifin Corporation, All Rights Reserved

Cat HY14-2533-infrtbckvr.indd, dd



**Contents**

**Pressure Control Valves (continued)**

Series RCP ..... Pressure Relief, In-line Pipe Mounted ..... 126 - 127

Series RP ..... Pressure Relief, In-line Pipe Mounted ..... 128 - 130

Series P6701 ..... Remote Pilot, In-line Pipe Mounted ..... 131 - 132

Series PR6701 ..... Pressure Reducing, In-line Pipe Mounted ..... 133 - 134

**Sandwich Valves**

Series SPC ..... Pressure Compensator ..... 135 - 137

Series ZDR ..... Pressure Reducing, Pilot Operated ..... 138 - 142

Series ZDV ..... Pressure Relief, Pilot Operated ..... 143 - 148

Series ZRD ..... Throttle with Check ..... 149 - 154

Series ZRE ..... Check, Pilot Operated ..... 155 - 159

Series ZRV ..... Check, Direct Operated ..... 160 - 162

**Involvement Training** ..... 163 - 171

**Terms of Sale with Warranty Limitations** ..... 172

**Safety Guide** ..... 173 - 174

### General Description

Series 2F1C 2-way flow control valves provide pressure and viscosity compensated flow from port A to port B. The counter direction is blocked (standard) or can be open via an integral reverse flow check valve (optional).

### Operation

The compensator spool is located in front of the metering spool. The metering spool is closed in the neutral position to avoid undesired initial actuator motion. The oil flow to open the metering spool has to pass a needle valve (not shown in the sectional drawing). The needle valve can be adjusted from the front panel to set the response time of the 2F1C.

The metering spool is adjusted by the main control knob. The key lock has three positions:

- Lock: Adjustment is locked.
- Adjust: Full adjustment is permitted.
- Trim: Fine adjustment of  $\pm 5\%$  is possible.

### Features

- 2 way flow control valve.
- Subplate mounting according to ISO 6263.
- Excellent fine adjustment.
- Adjustable response time.
- Closed in neutral position.
- Optional reverse flow check valve.
- 2 sizes: NG10 (3/8"), NG16 (3/4").

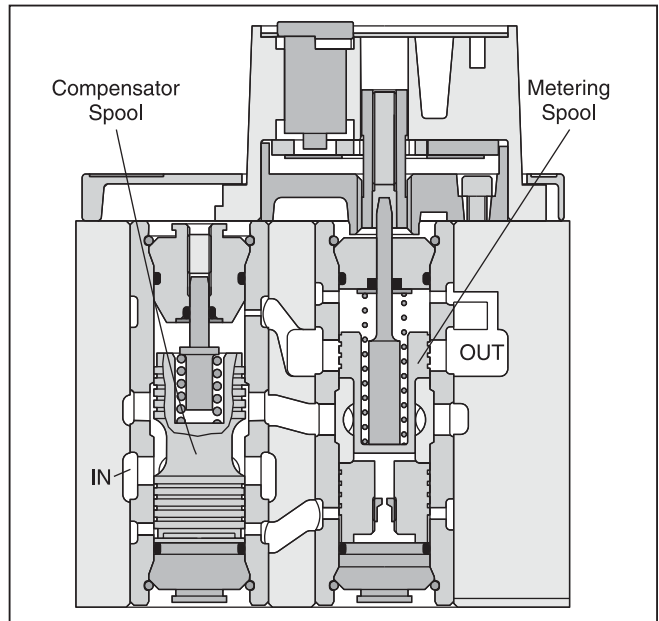
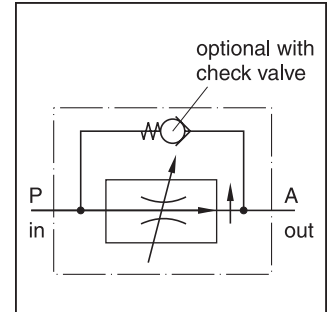

### Specifications

Size	NG10		NG16		
Actuator	Manual flow rate adjustment				
Mounting Type	ISO 6263				
Mounting Position	Unrestricted				
Fluid Temperature	+70°C (+158°F) Maximum				
Ambient Temperature	-25°C to +50°C (-13°F to +122°F)				
Viscosity Range	2.8 to 400 cSt (mm <sup>2</sup> /s)				
Filtration	15 μm				
Maximum Pressure Difference	See Diagram				
Maximum Operating Pressure	Port A	<b>2F1C02</b> 14 - 280 Bar (203 - 4060 PSI)		<b>2F1C03</b> 14 - 350 Bar (203 - 5075 PSI)	
	Port B	0 - 270 Bar (0 - 3915 PSI)		0 - 340 Bar (0 - 4930 PSI)	
Flow Direction	A-B	Flow control function			
	B-A	Blocked or free flow through check valve			



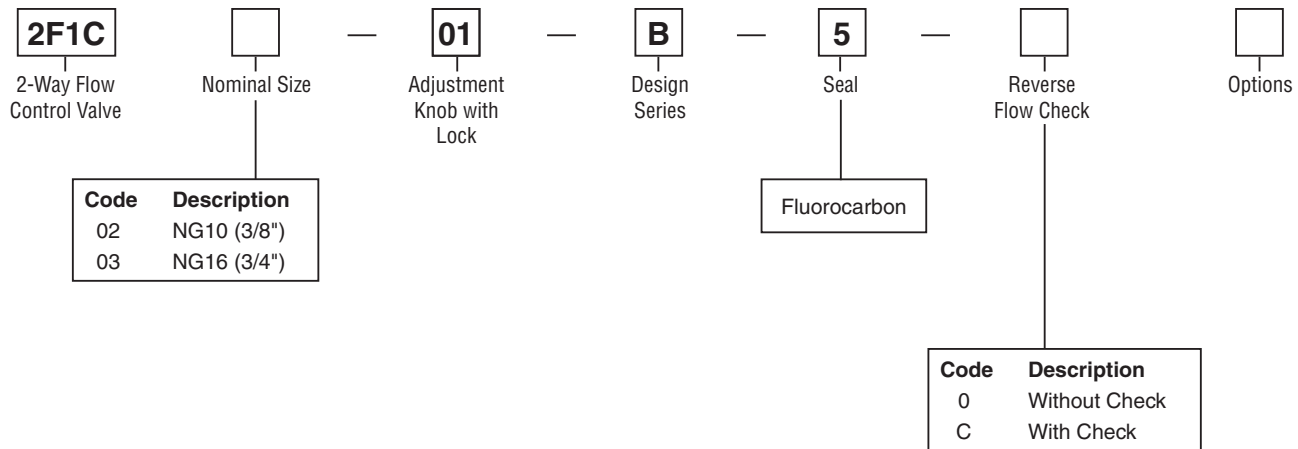

**Weight:**

- 2F1C02 6.0 kg (13.2 lbs.)
- 2F1C03 9.0 kg (19.8 lbs.)

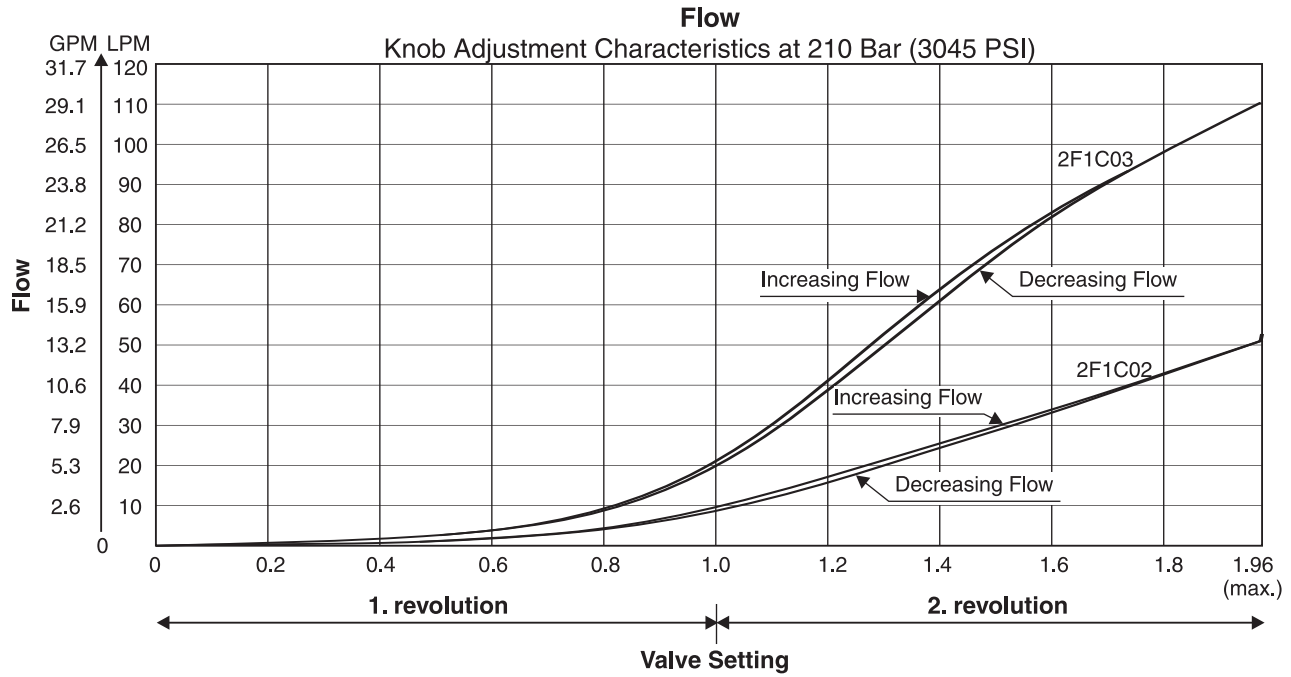

**2F1C02**

**Flow / Pressure Drop**

Constant Inlet Pressure – Variable Outlet Pressure

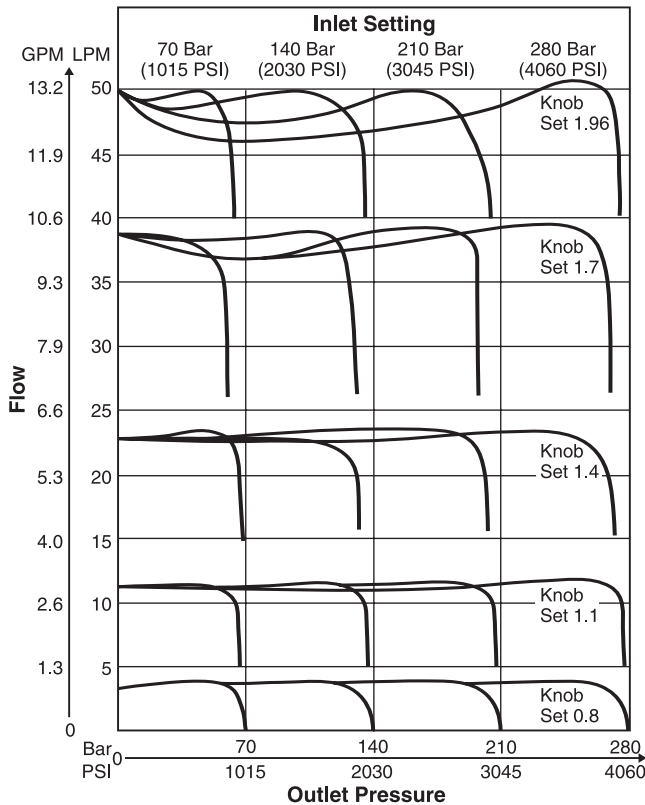

**2F1C03**

**Flow / Pressure Drop**

Constant Inlet Pressure – Variable Outlet Pressure

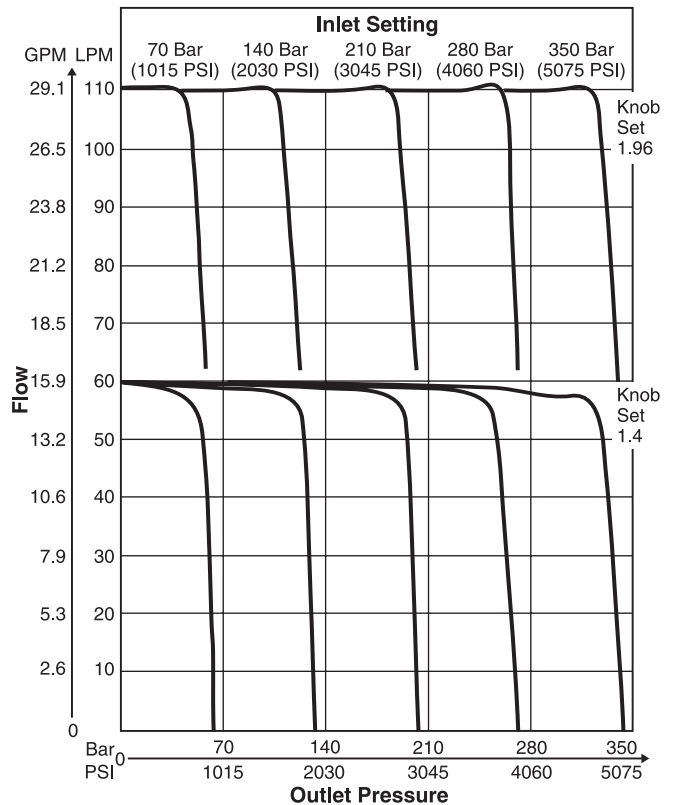

Fluid viscosity 40 cSt at 50°C (122°F)

2F1C.indd, dd

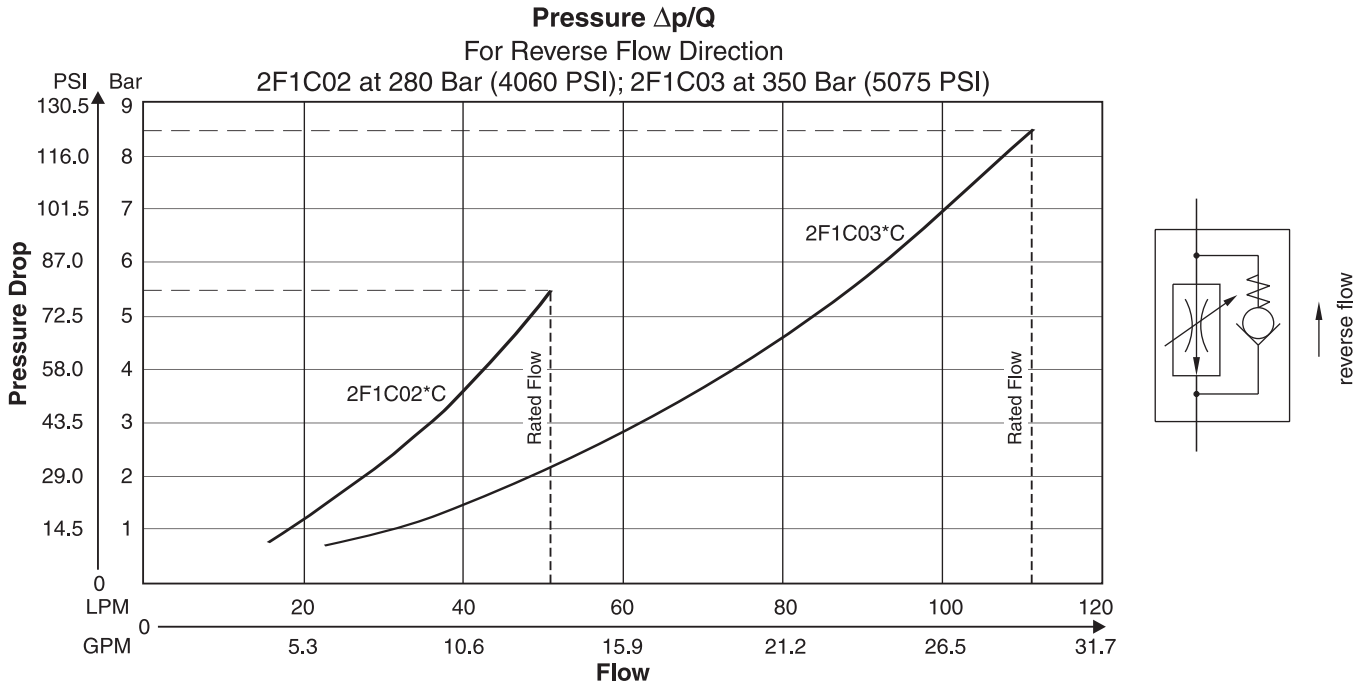

**2F1C02**

**Minimum Pressure Difference Curves**  
 Fluid Viscosity 40cSt at 50°C (°F)

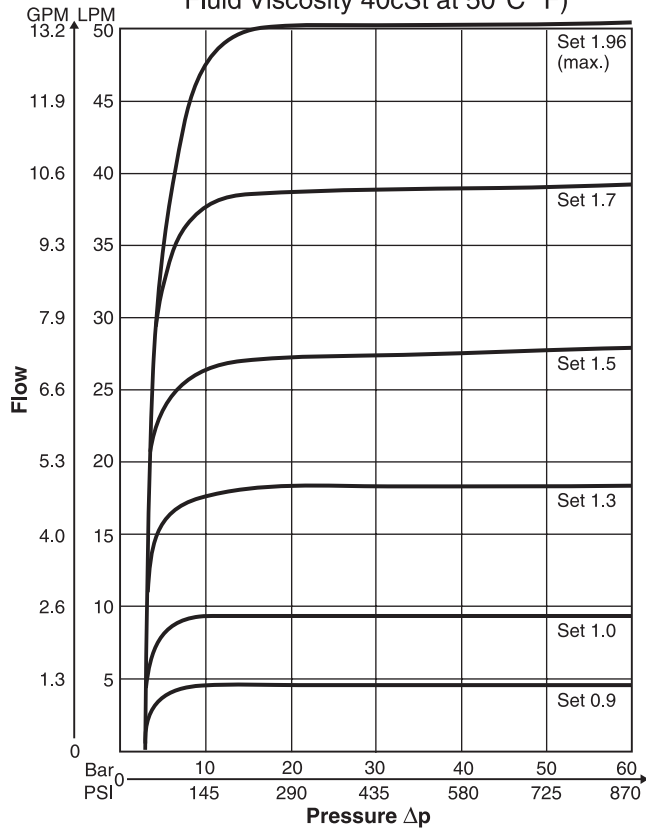

**2F1C03**

**Minimum Pressure Difference Curves**  
 Fluid Viscosity 40cSt at 50°C (°F)

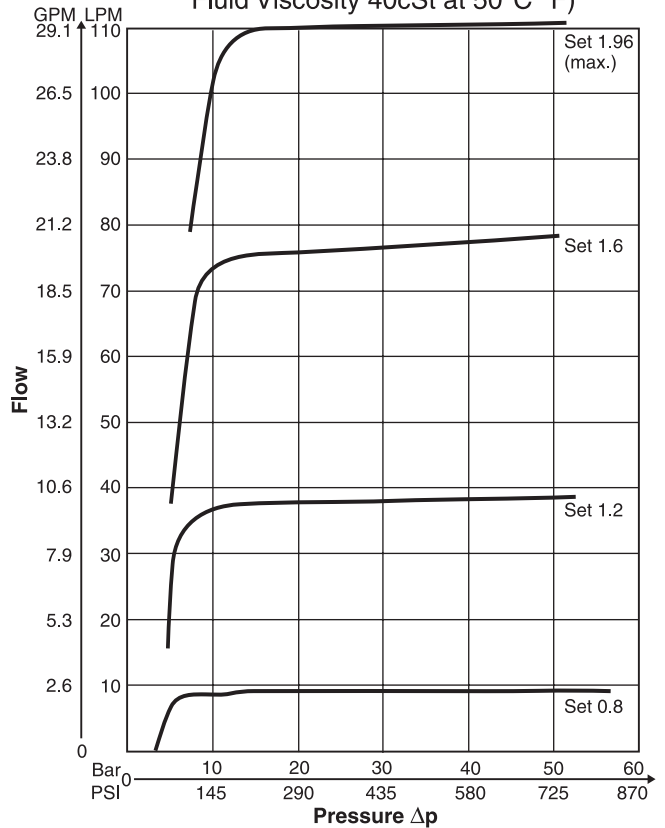

Fluid viscosity 40 cSt at 50°C (122°F)

2F1C.indd, dd

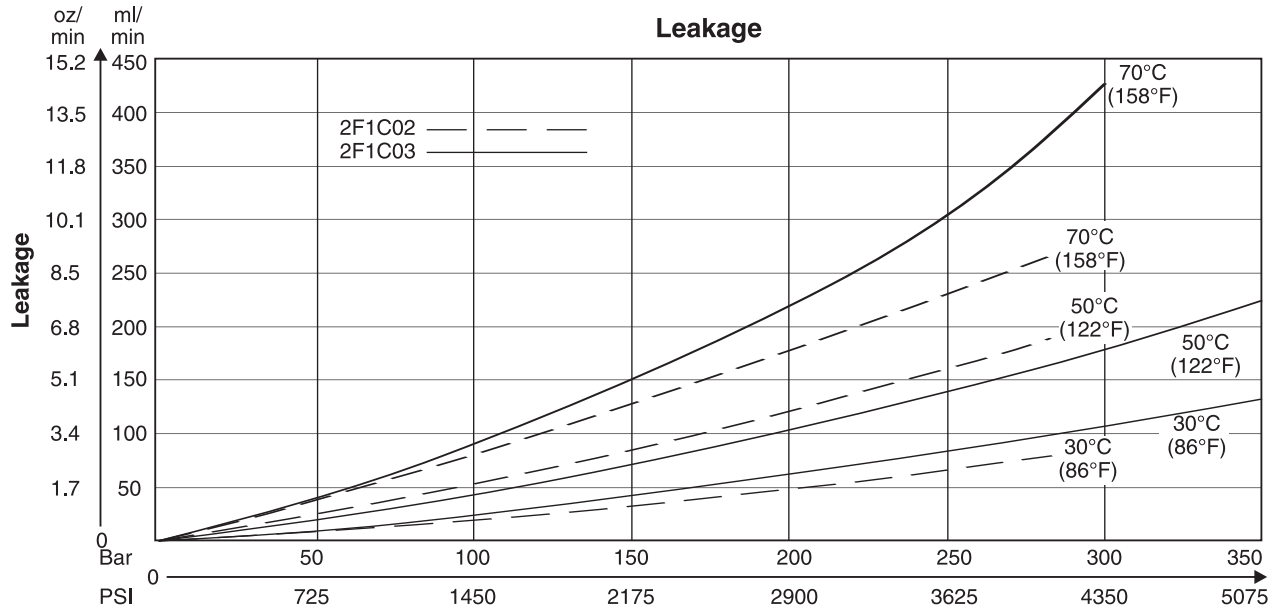

**2F1C02**

**Flow / Temperature Curves  
 at 210 Bar (3045 PSI)**

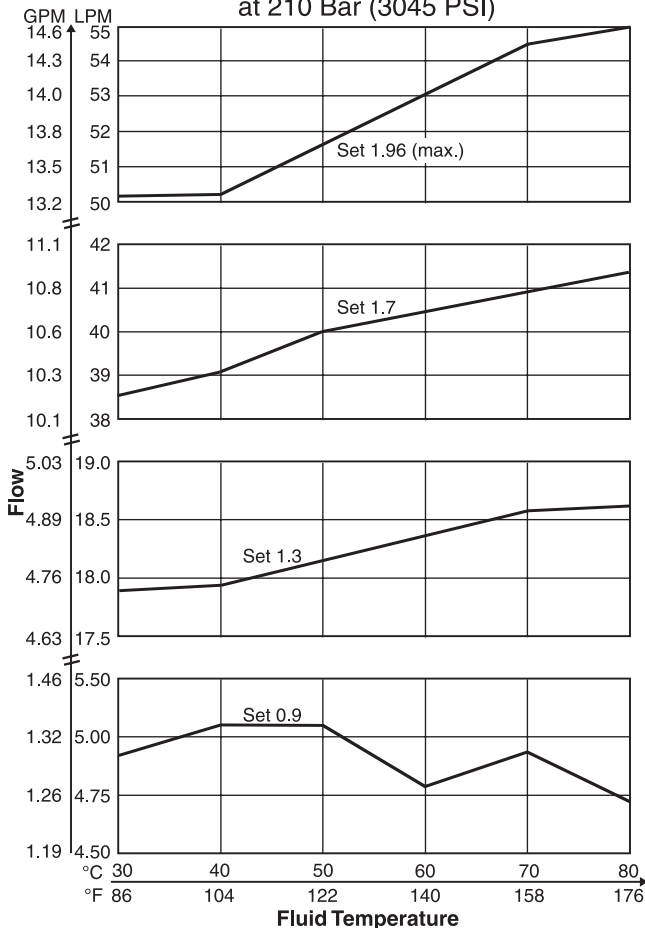

**2F1C03**

**Flow / Temperature Curves  
 at 210 Bar (3045 PSI)**

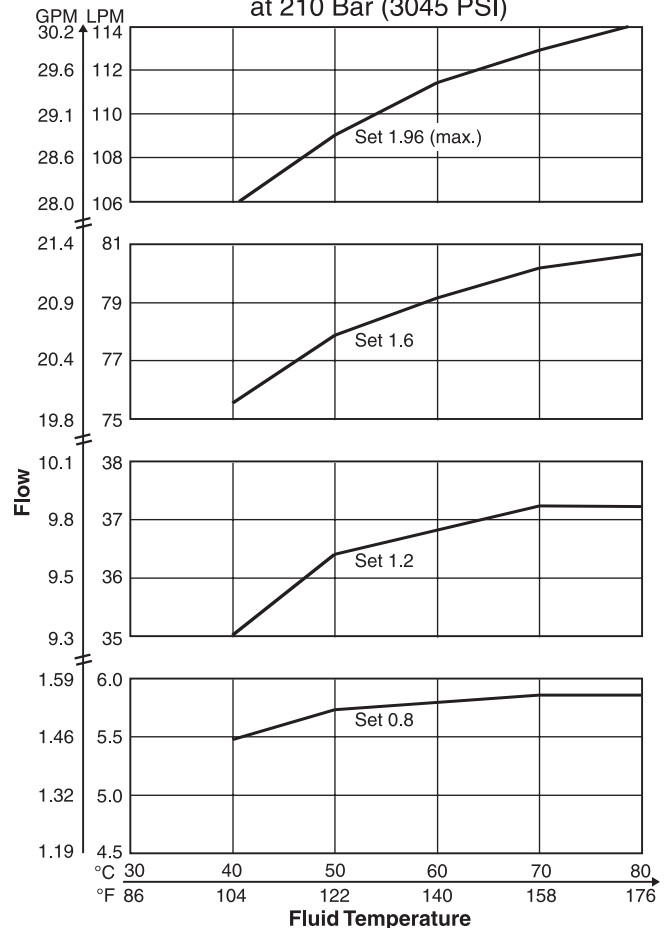

Fluid viscosity 40 cSt at 50°C (122°F)

2F1C.indd, dd



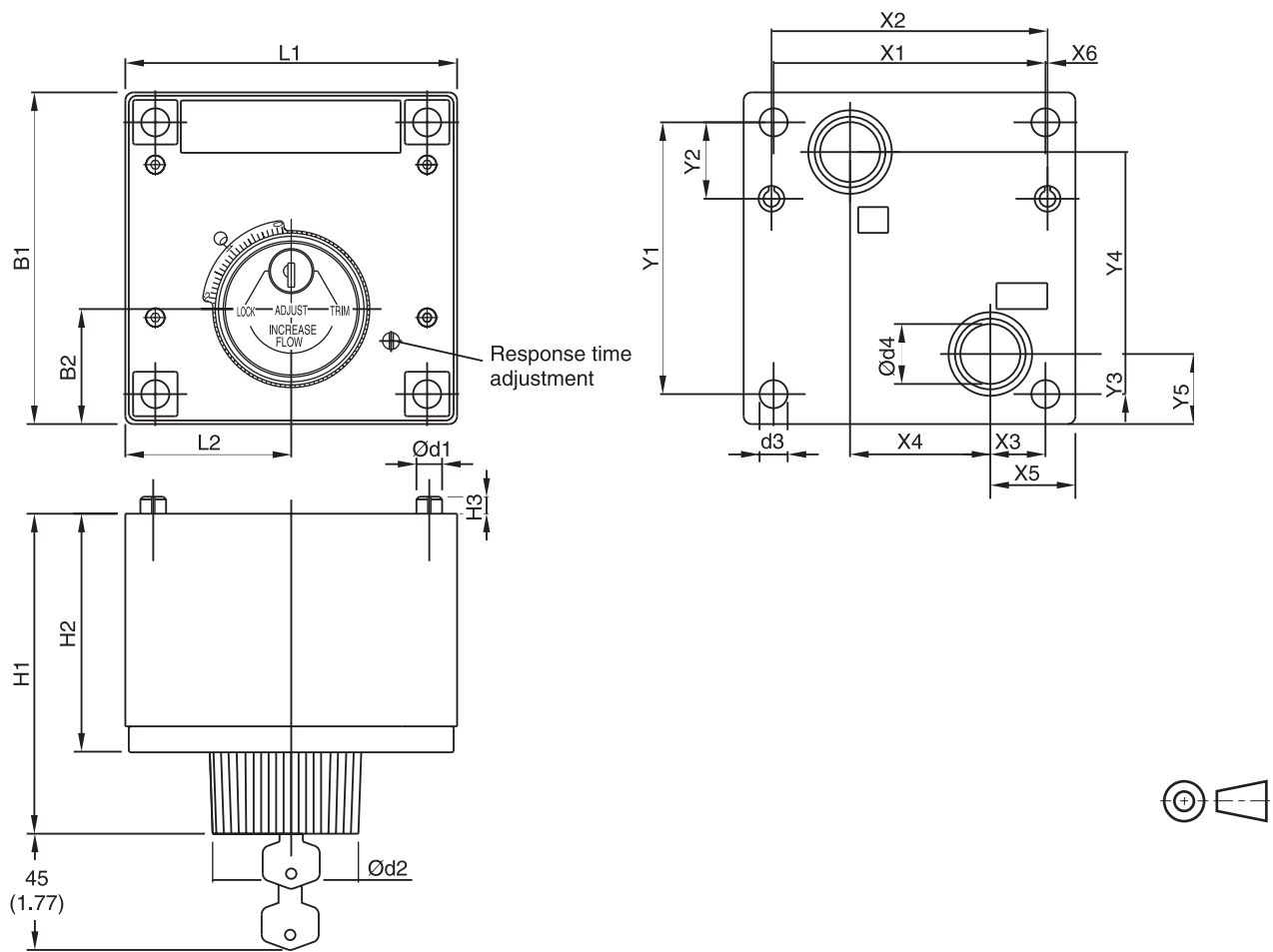

Inch equivalents for millimeter dimensions are shown in (\*\*)



Size	ISO-code	x1	x2	x3	x4	x5	x6	y1	y2	y3	y4	y5
02	6263-AM-07-2-A	76.2 (3.00)	79.4 (3.13)	9.5 (0.37)	44.5 (1.75)	19.0 (0.75)	-	82.5 (3.25)	23.8 (0.94)	30.2 (1.19)	41.3 (1.63)	39.7 (1.56)
03	6263-AK-06-2-A	101.6 (4.00)	103.2 (4.06)	20.6 (0.81)	52.4 (2.06)	31.8 (1.25)	0.8 (0.03)	101.6 (4.00)	28.6 (1.13)	15.1 (0.59)	75.4 (2.97)	26.2 (1.03)

Size	ISO-code	B1	B2	H1	H2	H3	L1	L2	d1	d2	d3	d4
02	6263-AM-07-2-A	101.6 (4.00)	38.1 (1.50)	119.6 (4.71)	87.4 (3.44)	6.4 (0.25)	95.2 (3.75)	47.6 (1.87)	6.4 (0.25)	57.2 (2.25)	8.7 (0.34)	14.2 (0.56)
03	6263-AK-06-2-A	123.8 (4.87)	42.9 (1.69)	121.4 (4.78)	89.2 (3.51)	6.4 (0.25)	123.8 (4.87)	61.9 (2.44)	9.5 (0.37)	57.2 (2.25)	10.5 (0.41)	22.4 (0.88)

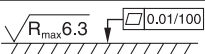
Size	ISO-Code	Bolt kit -  <b>DIN912 12.9</b>		 Kit	Surface Finish
02	6263-AM-07-2-A	BK-700-70842-8 4xM8x100	31.8 Nm (23.5 lb.-ft.) ±15%	on request	
03	6263-AK-06-2-A	BK395 4xM10x100	63 Nm (46.5 lb.-ft.) ±15%	on request	

### General Description

Series C5P pilot operated check valves have a similar design to the subplate mounted SVL series. The SAE flanges allow to mount directly on the flanges of actuators to achieve a very compact design.

### Operation

When no pressure is applied to the X-port, the flow from B to A is blocked, because the pressure in B is also in effect on top of the poppet.

Pressurizing the X port relieves the area on top of the poppet to the drain port and allows flow from B to A.

The seat design of the C5P valve series provides leak-free separation of port A and B in the closed position.

### Features

- Pilot operated check valve.
- 2-port body with SAE 61 flange.
- 3 sizes (SAE 3/4", 1", 1 1/4").
- 4 opening ratios.

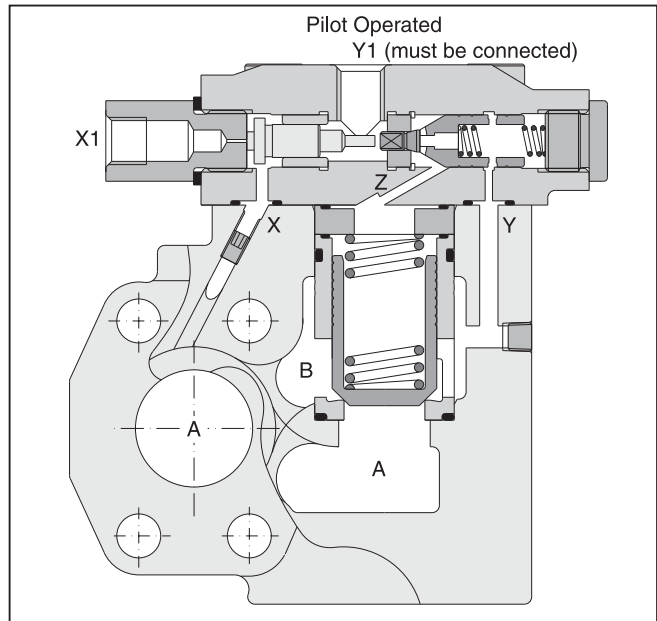
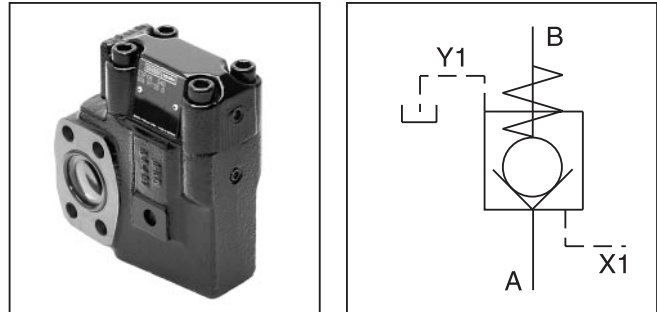

### Specifications

General				
Size		06	08	10
Mounting		2-port in-line flange SAE 61		
Mounting Position		Unrestricted		
Ambient Temperature		-20°C to +50°C (-4°F to +122°F)		
Hydraulic				
Maximum Operating Pressure	Ports A, B Port Y1	350 Bar (5075 PSI) 30 Bar (435 PSI)	350 Bar (5075 PSI) 30 Bar (435 PSI)	280 Bar (4060 PSI) 30 Bar (435 PSI)
Nominal Flow		180 LPM (47.6 GPM)	360 LPM (95.2 GPM)	600 LPM (158.7 GPM)
Fluid		Hydraulic oil in accordance with DIN 51524...51525		
Fluid Temperature		-20°C to +80°C (-4°F to +176°F)		
Viscosity Permitted		10 to 650 cSt (mm <sup>2</sup> /s)		
Viscosity Recommended		30 cSt (mm <sup>2</sup> /s)		
Filtration		ISO 4406 (1999) 18/16/13 (acc. NAS 1638: 7)		

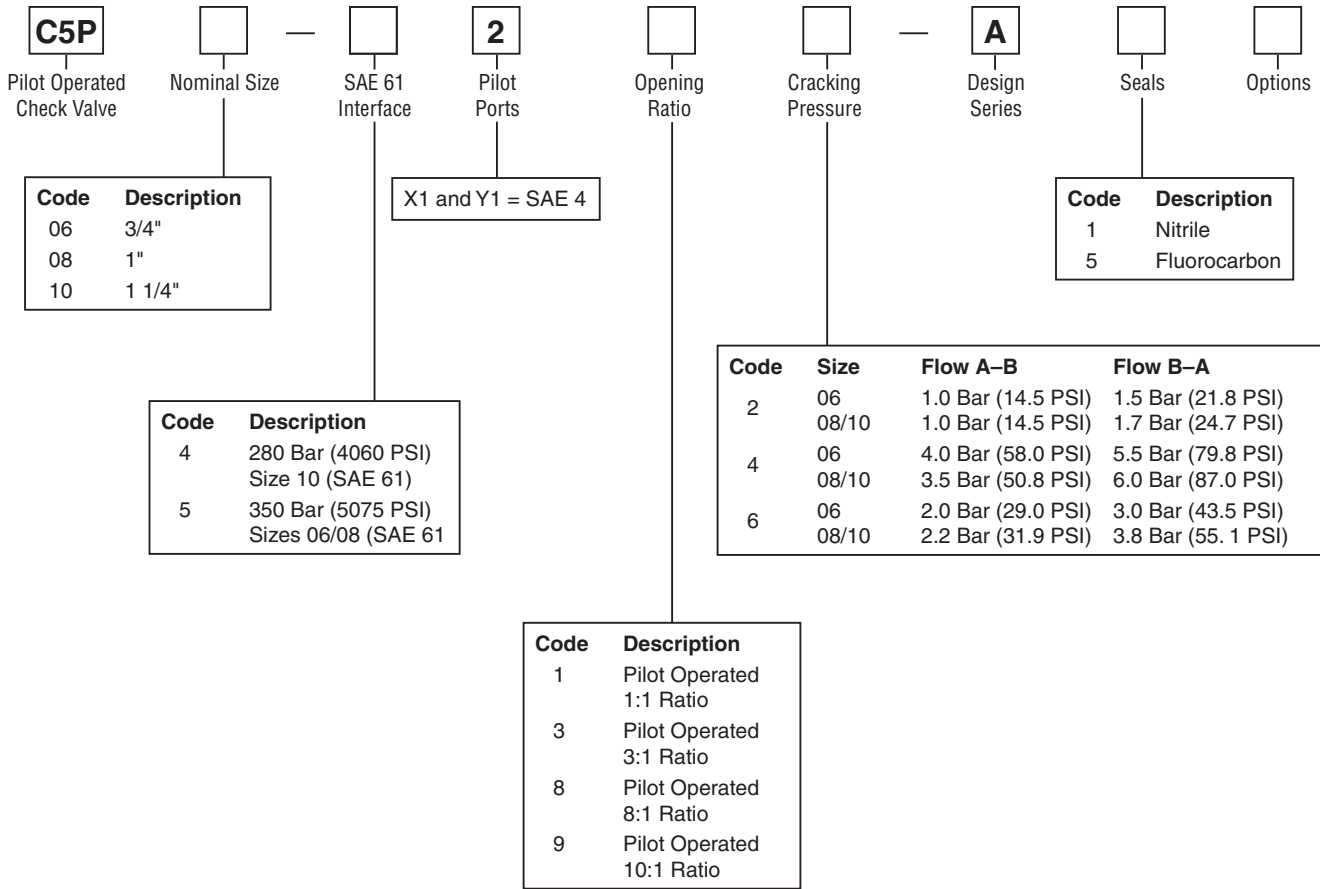

**Weight:**

- C5P06 3.9 kg (8.6 lbs.)
- C5P08 4.4 kg (9.7 lbs.)
- C5P10 5.7 kg (12.6 lbs.)



**C5P06**

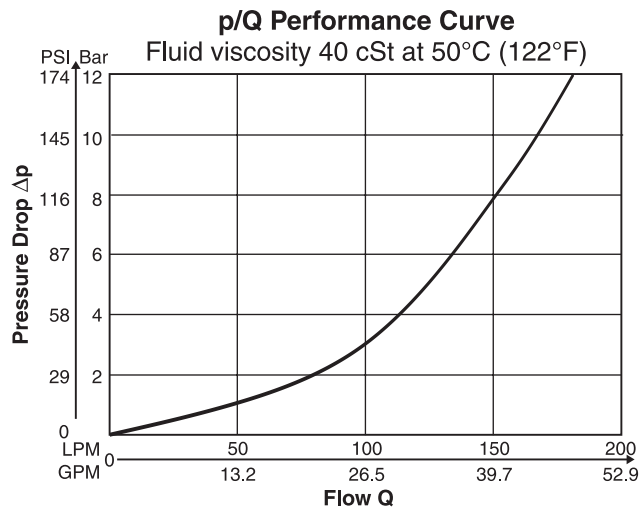

**C5P08**

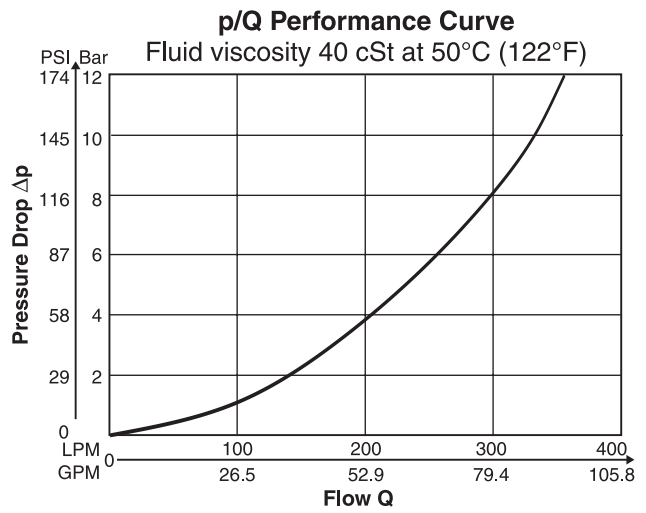

**C5P10**

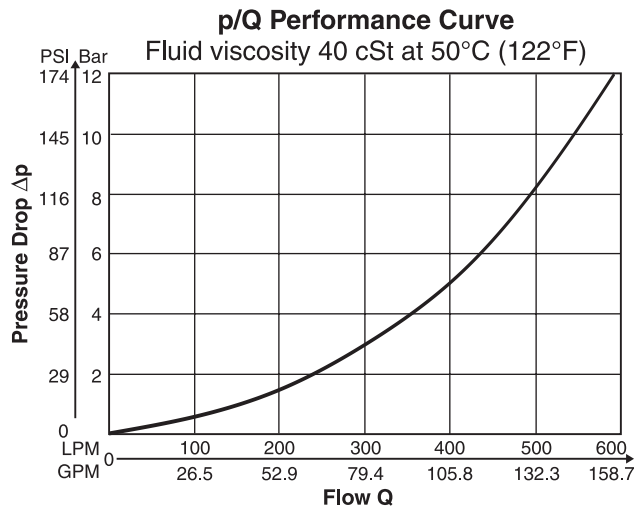

Inch equivalents for millimeter dimensions are shown in (\*\*)

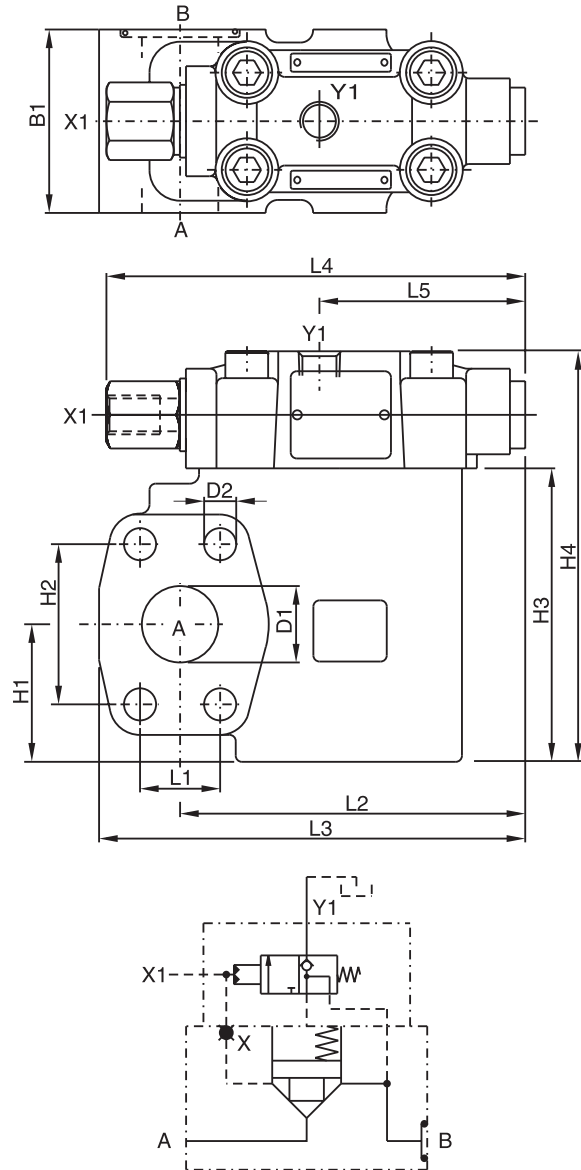

**Dimensions**

Series	L1	L2	L3	L4	L5	B1	H1	H2	H3	H4	D1	D2
C5P06	22.2 (0.87)	95.8 (3.77)	119.8 (4.72)	137.0 (5.39)	67.3 (2.65)	60.0 (2.36)	37.0 (1.46)	47.6 (1.87)	90.0 (3.54)	128.0 (5.04)	19.0 (0.75)	10.5 (0.41)
C5P08	26.2 (1.03)	112.9 (4.44)	139.4 (5.49)	137.0 (5.39)	67.3 (2.65)	60.0 (2.36)	45.0 (1.77)	52.4 (2.06)	96.0 (3.78)	134.0 (5.28)	25.0 (0.93)	10.5 (0.41)
C5P10	30.2 (1.19)	112.9 (4.44)	146.9 (5.78)	137.0 (5.39)	67.3 (2.65)	75.0 (2.95)	48.0 (1.39)	58.7 (2.31)	109.0 (4.29)	147.0 (5.79)	32.0 (1.26)	12.5 (0.49)

**Ports**

Port	Function	Port Size		
		C5P06	C5P08	C5P10
A	Inlet or Outlet	3/4" SAE 61	1" SAE 61	1 1/4" SAE 61
B	Outlet or Inlet	3/4" SAE 61	1" SAE 61	1 1/4" SAE 61
X1	External Pilot Port	SAE 4		
Y1	External Pilot Drain	SAE 4		

C5Pindd, dd



### General Description

Series C5V direct operated check valves provide free flow in one direction and block the flow in the counter direction.

The SAE flanges allow to mount the C5V directly on the pressure port of pumps for protection against pressure shocks from the system.

### Operation

The ball is held on its seat by a spring under zero pressure condition. When flow is increased to the cracking pressure, free flow is allowed from port A to port B. Blocked flow is created when operating pressure and spring on Port B exceed pressure on port A.

### Features

- Direct operated check valve.
- SAE 61 and SAE 62 flanges.
- 4 sizes (SAE 3/4", 1", 1 1/4", 1 1/2").
- 3 springs.
- 2 different seal configurations.

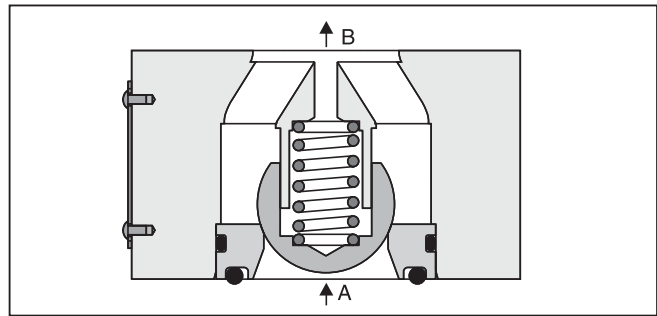
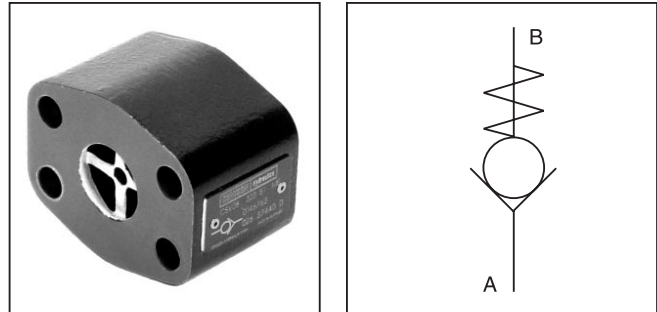

### Specifications

General				
Size	06	08	10	12
<b>Mounting</b>	2-port in-line flange SAE 61 and SAE 62			
<b>Mounting Position</b>	Unrestricted			
<b>Ambient Temperature</b>	-20°C to +50°C (-4°F to +122°F)			
Hydraulic				
<b>Maximum Operating Pressure</b>				
<b>SAE 61</b>	350 Bar (5075 PSI)	350 Bar (5075 PSI)	280 Bar (4060 PSI)	210 Bar (3045 PSI)
<b>SAE 62</b>	420 Bar (6090 PSI)	420 Bar (6090 PSI)	420 Bar (6090 PSI)	—
<b>Nominal Flow</b>	100 LPM (26.5 GPM)	200 LPM (52.9 GPM)	400 LPM (105.8 GPM)	750 LPM (198.4 GPM)
<b>Fluid</b>	Hydraulic oil in accordance with DIN 51524...51525			
<b>Fluid Temperature</b>	-20°C to +80°C (-4°F to +176°F)			
<b>Viscosity Permitted</b>	10 to 650 cSt (mm <sup>2</sup> /s)			
<b>Viscosity Recommended</b>	30 cSt (mm <sup>2</sup> /s)			
<b>Filtration</b>	ISO 4406 (1999) 18/16/13 (acc. NAS 1638: 7)			

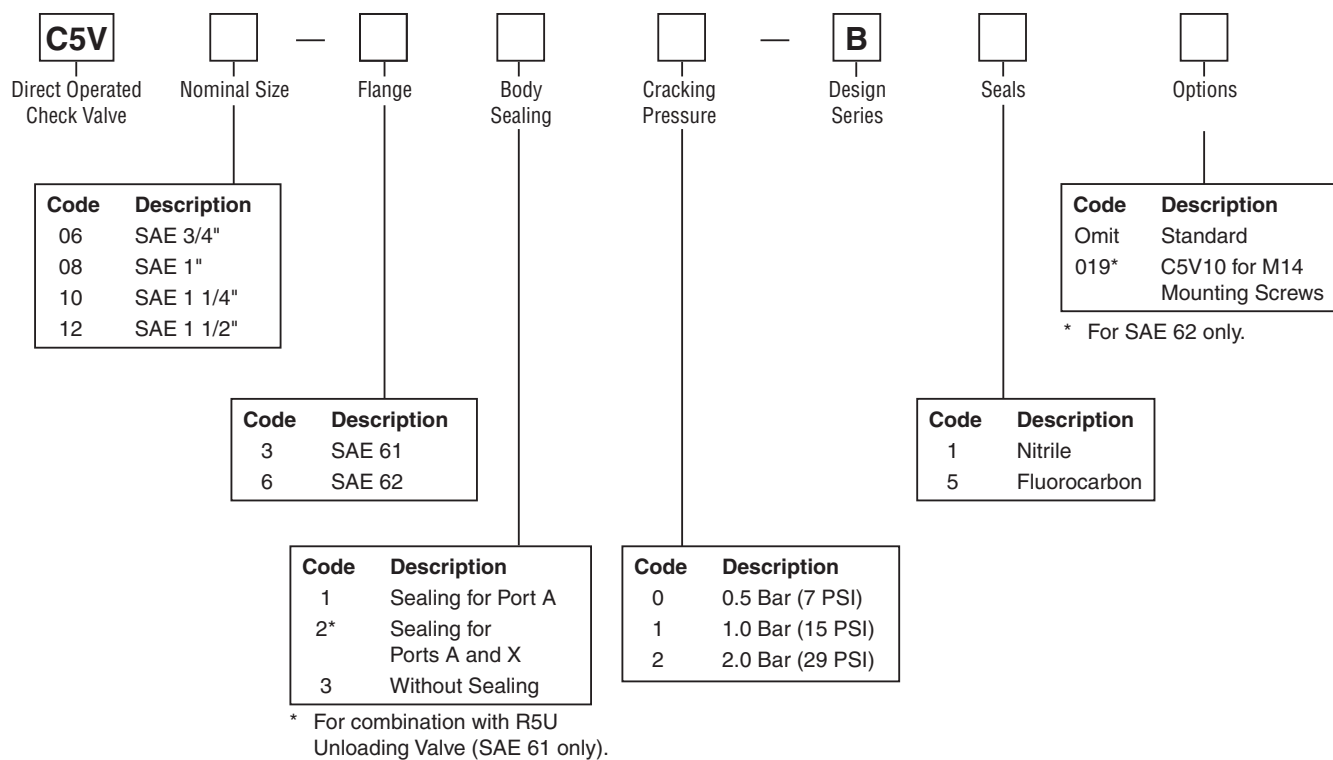

**Weight:**

C5V06	0.6 kg (1.3 lbs.)
C5V08	0.9 kg (2.0 lbs.)
C5V10	1.3 kg (2.9 lbs.)
C5V12	1.8 kg (4.0 lbs.)

**C5V06**

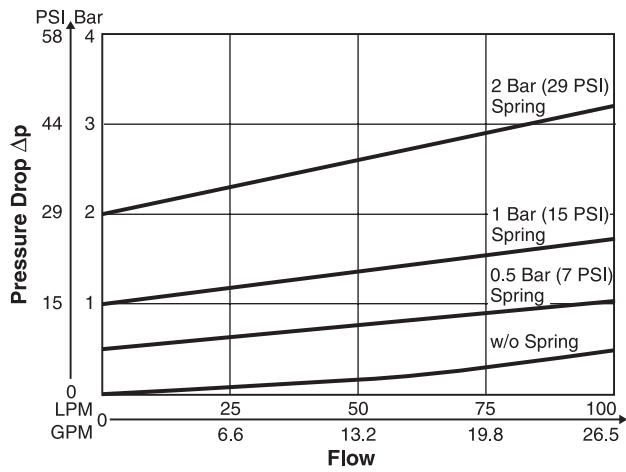

**C5V08**

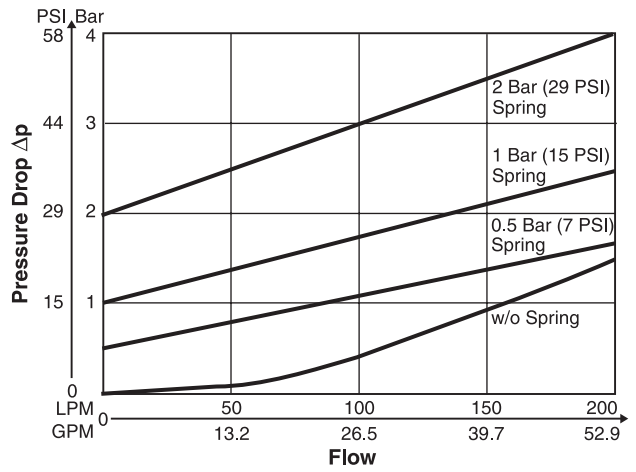

**C5V10**

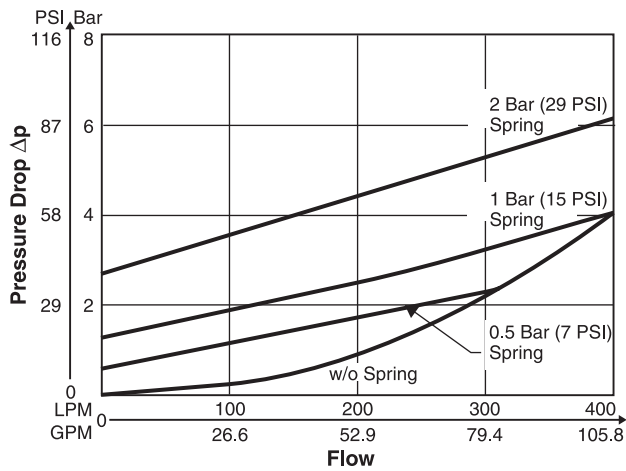

**C5V12**

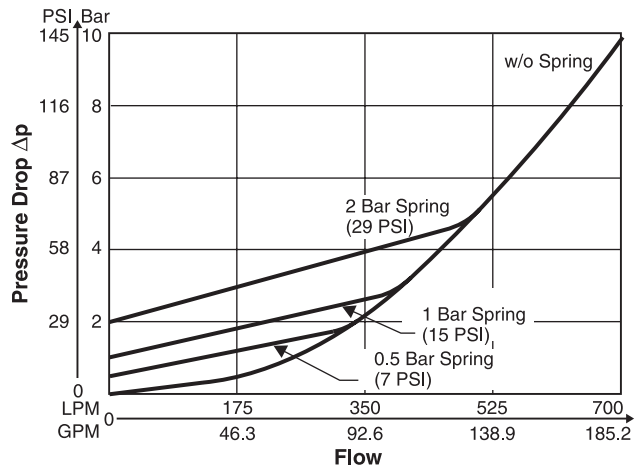

Inch equivalents for millimeter dimensions are shown in (\*\*)

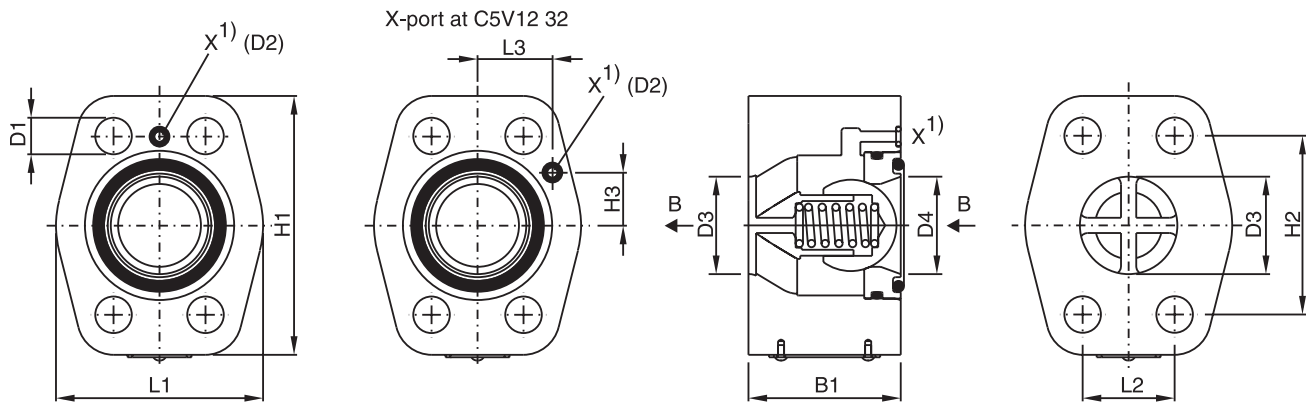

1) X1 port for C5V\*32\* (for use with Unloading Valve R5U)

Series	Nominal Size	L1	L2	L3	H1	H2	H3	B1	D1	D2	D3 + 0.8	D4	
C5V06	3/4"	SAE 61	48.0 (1.89)	22.2 (0.87)	27.2 (1.07)	64.0 (2.52)	47.6 (1.87)	22.4 (0.88)	45.0 (1.77)	10.5 (0.41)	Ø3.0 (0.12)	19.0 (0.75)	19.0 (0.75)
		SAE 62	48.0 (1.89)	23.8 (0.94)	27.2 (1.07)	64.0 (2.52)	50.8 (2.00)	22.4 (0.88)	45.0 (1.77)	10.5 (0.41)	-	19.0 (0.75)	19.0 (0.75)
C5V08	1"	SAE 61	60.0 (2.36)	26.2 (1.03)	27.2 (1.07)	74.0 (2.91)	52.4 (2.06)	22.4 (0.88)	45.0 (1.77)	10.5 (0.41)	Ø3.0 (0.12)	25.0 (0.98)	25.0 (0.98)
		SAE 62	60.0 (2.36)	27.8 (1.09)	27.2 (1.07)	74.0 (2.91)	57.2 (2.25)	22.4 (0.88)	45.0 (1.77)	12.5 (0.49)	-	25.0 (0.98)	25.0 (0.98)
C5V10	1 1/4"	SAE 61	68.0 (2.68)	30.2 (1.19)	27.2 (1.07)	85.0 (3.35)	58.7 (2.31)	22.4 (0.88)	50.0 (1.97)	12.5 (0.49)	Ø3.0 (0.12)	32.0 (1.26)	32.0 (1.26)
		SAE 62	68.0 (2.68)	31.8 (1.25)	27.2 (1.07)	85.0 (3.35)	66.7 (2.63)	22.4 (0.88)	50.0 (1.97)	13.5* (0.53)	-	32.0 (1.26)	32.0 (1.26)
C5V12	1 1/2"	SAE 61	80.0 (3.15)	35.7 (1.41)	27.2 (1.07)	104.0 (4.09)	69.8 (2.75)	22.4 (0.88)	50.0 (1.97)	13.5 (0.53)	Ø3.0 (0.12)	42.0 (1.65)	38.0 (1.50)
		SAE 62	80.0 (3.15)	36.5 (1.44)	27.2 (1.07)	104.0 (4.09)	79.4 (3.13)	22.4 (0.88)	50.0 (1.97)	17.0 (0.67)	-	42.0 (1.65)	38.0 (1.50)

\* D1 = 15 (0.59) at option code 019 for M14 mounting screws.

**General Description**

Series SPR direct operated check valves allow free flow from A to B. The counter direction is blocked. Series SPR valves are equipped with a leak-free seat type cartridge.

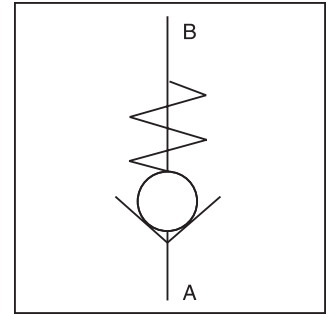

**Operation**

The pressure arising in port A lifts the poppet from the valve seat and releases the flow to B. In the counter direction, the spring and the pressure on top of the cartridge hold the poppet onto the seat and block the flow.

**Features**

- High flow, low pressure drop design.
- Minimal internal leakage.

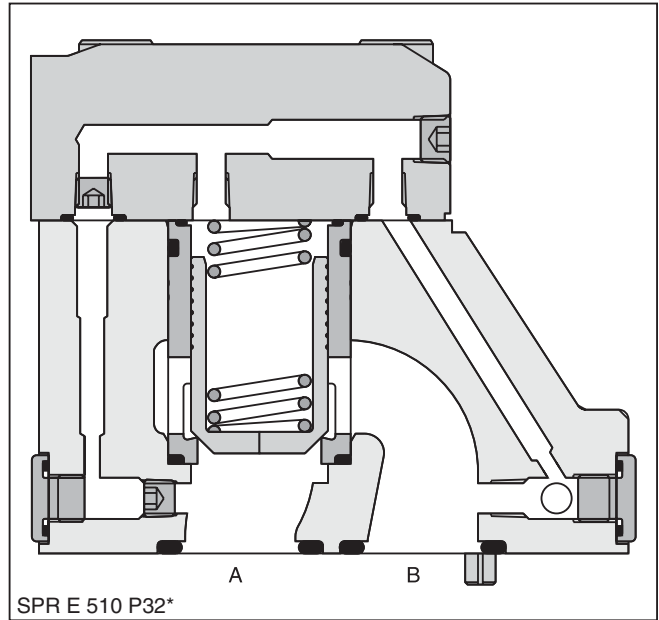

**Specifications**

General			
Size	NG10	NG25	NG32
Suplate Mounting	ISO 5781		
Mounting Position	Unrestricted		
Ambient Temperature Range	-20°C to +80°C (-4°F to +176°F)		
Hydraulic			
Maximum Operating Pressure	350 Bar (5075 PSI)		
Pressure Stages	105 Bar (1523 PSI), 210 Bar (3045 PSI), 350 Bar (5075 PSI)		
Nominal Flow	150 LPM (39.7 GPM)	270 LPM (71.4 GPM)	450 LPM (119.0 GPM)
Fluid	Hydraulic oil to DIN 51524		
Viscosity	Recommended	30 to 50 cSt (mm <sup>2</sup> /s)	
	Permitted	20 to 380 cSt (mm <sup>2</sup> /s)	
Fluid Temperature	Recommended	+30°C to +50°C (86°F to +122°F)	
	Permitted	-20°C to +70°C (-4°F to +158°F)	
Filtration	ISO Class 4406 (1999) 18/16/13		



**Ordering Information**

<input type="checkbox"/>	<b>SPR</b>	<b>E</b>	<b>510</b>	<input type="checkbox"/>	<input type="checkbox"/>	<input type="checkbox"/>														
Seals	Check Valve	Design Series	Series	Valve Size	Opening Pressure	Design Series														
<table border="1" style="width: 100%; border-collapse: collapse;"> <thead> <tr> <th>Code</th> <th>Description</th> </tr> </thead> <tbody> <tr> <td>Omit</td> <td>Nitrile</td> </tr> <tr> <td>V</td> <td>Fluorocarbon</td> </tr> </tbody> </table>		Code	Description	Omit	Nitrile	V	Fluorocarbon			<table border="1" style="width: 100%; border-collapse: collapse;"> <thead> <tr> <th>Code</th> <th>Description</th> </tr> </thead> <tbody> <tr> <td>P15</td> <td>NG10</td> </tr> <tr> <td>P20</td> <td>NG25</td> </tr> <tr> <td>P32</td> <td>NG32</td> </tr> </tbody> </table>		Code	Description	P15	NG10	P20	NG25	P32	NG32	NOTE: Not required when ordering
Code	Description																			
Omit	Nitrile																			
V	Fluorocarbon																			
Code	Description																			
P15	NG10																			
P20	NG25																			
P32	NG32																			
<p><b>Weight:</b></p> <p>*SPR*P15 2.8 kg (6.2 lbs.)</p> <p>*SPR*P20 4.6 kg (10.1 lbs.)</p> <p>*SPR*P32 6.1 kg (13.5 lbs.)</p>				<table border="1" style="width: 100%; border-collapse: collapse;"> <thead> <tr> <th>Code</th> <th>Description</th> </tr> </thead> <tbody> <tr> <td>N</td> <td>0.5 Bar (7.3 PSI)</td> </tr> <tr> <td>R</td> <td>1.0 Bar (14.5 PSI)</td> </tr> <tr> <td>T</td> <td>2.0 Bar (29 PSI)</td> </tr> <tr> <td>U</td> <td>4.0 Bar (58 PSI)</td> </tr> </tbody> </table>		Code	Description	N	0.5 Bar (7.3 PSI)	R	1.0 Bar (14.5 PSI)	T	2.0 Bar (29 PSI)	U	4.0 Bar (58 PSI)					
Code	Description																			
N	0.5 Bar (7.3 PSI)																			
R	1.0 Bar (14.5 PSI)																			
T	2.0 Bar (29 PSI)																			
U	4.0 Bar (58 PSI)																			

**Performance Curve**

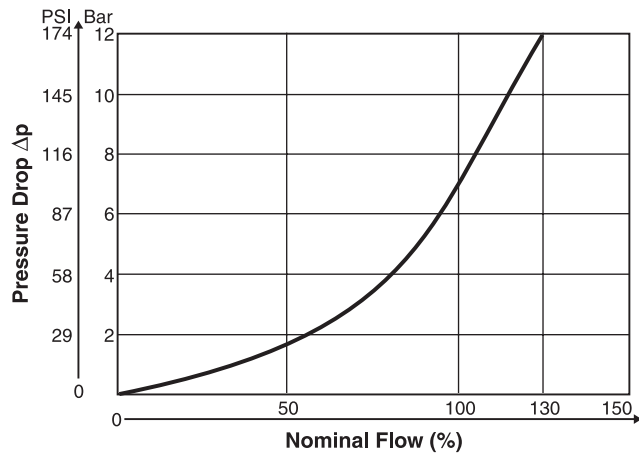

**Dimensions**

**Direct Operated Check Valve  
Series SPR**

Inch equivalents for millimeter dimensions are shown in (\*\*)

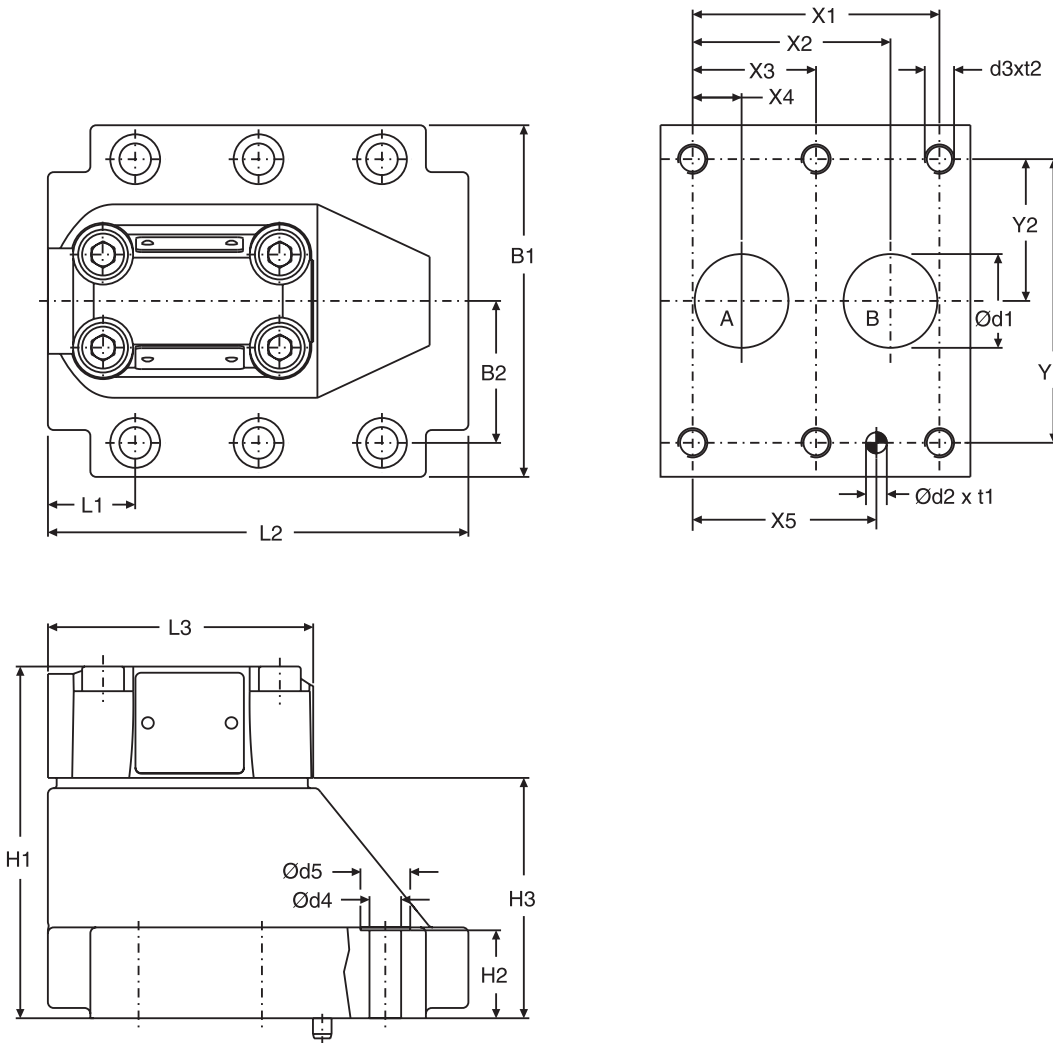

NG	ISO-code	x1	x2	x3	x4	x5	y1	y2	B1	B2	H1	H2	H3	L1	L2
10	5781-06-07-0-00	42.9 (1.69)	35.8 (1.41)	-	7.2 (0.28)	31.8 (1.25)	66.7 (2.63)	33.4 (1.31)	87.3 (3.44)	33.4 (1.31)	83.0 (3.27)	21.0 (0.83)	45.0 (1.77)	29.0 (1.14)	94.8 (3.73)
25	5781-08-10-0-00	60.3 (2.37)	49.2 (1.94)	-	11.1 (0.44)	44.5 (1.75)	79.4 (3.13)	39.7 (1.56)	105.0 (4.13)	39.7 (1.56)	109.5 (4.31)	29.0 (1.14)	71.5 (2.81)	34.7 (1.37)	126.8 (4.99)
32	5781-10-13-0-00	84.2 (3.31)	67.5 (2.66)	42.1 (1.66)	16.7 (0.66)	62.7 (2.47)	96.8 (3.81)	48.4 (1.91)	120.0 (4.72)	48.4 (1.91)	120.0 (4.72)	29.0 (1.14)	82.0 (3.23)	30.6 (1.20)	144.3 (5.68)

Tolerance for all dimensions ±0.2 mm (0.01 inches)

NG	ISO-code	d1max	d2	t1	d3	t2	d4	d5
10	5781-06-07-0-00	15.0 (0.59)	7.1 (0.28)	8.0 (0.31)	M10	16.0 (0.63)	10.8 (0.43)	17.0 (0.67)
25	5781-08-10-0-00	23.4 (0.92)	7.1 (0.28)	8.0 (0.31)	M10	18.0 (0.71)	10.8 (0.43)	17.0 (0.67)
32	5781-10-13-0-00	32.0 (1.26)	7.1 (0.28)	8.0 (0.31)	M10	20.0 (0.79)	10.8 (0.43)	17.0 (0.67)

NG	ISO-code	Kit		Kit		Surface finish
10	5781-06-07-0-00	BK-M10 x 35-4pcs	68 Nm (50.2 lb-ft)	SK-SVLE5P10	SK-SVLE5P10V	
25	5781-08-10-0-00	BK-M10 x 45-4pcs	68 Nm (50.2 lb-ft)	SK-SVLE5P25	SK-SVLE5P25V	
32	5781-10-13-0-00	BK-M10 x 45-6pcs	68 Nm (50.2 lb-ft)	SK-SVLE5P32	SK-SVLE5P32V	

SPR.indd, dd

### General Description

Series SVLE hydraulically pilot operated check valves allow free flow from A to B. The counter-flow direction is blocked.

When pressure is applied to control port X, the ring chamber flow from B to A is released.

Up to four different pilot control ratios are available (see Ordering Information).

Check valves allow free flow from A to B. The counter direction is blocked. The SPR series are equipped with a leak-free seat type cartridge.

### Operation

When no pressure is applied to the X-port, the flow from B to A is blocked, because the pressure in B is also in effect on top of the poppet.

Pressurizing the X port relieves the area on top of the poppet to the drain port and allows flow from B to A.

The seat design of the SVL valve series provides leak-free separation of port A and B in the closed position.

### Features

- High flow, low pressure drop design.
- Minimal internal leakage.

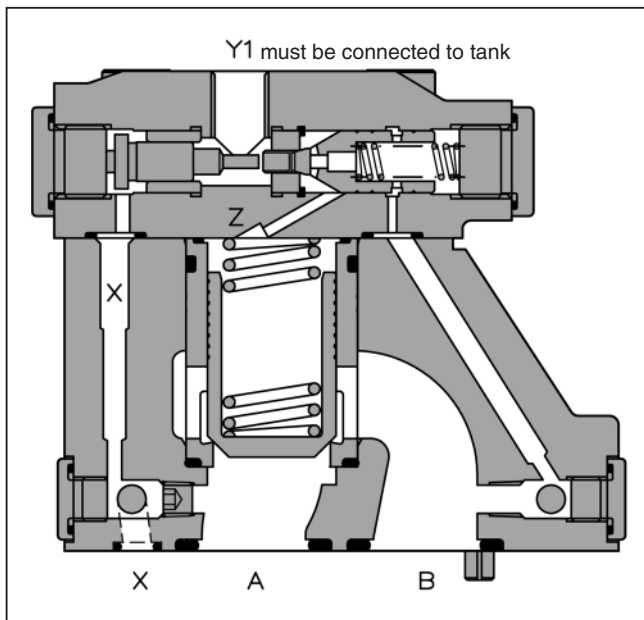
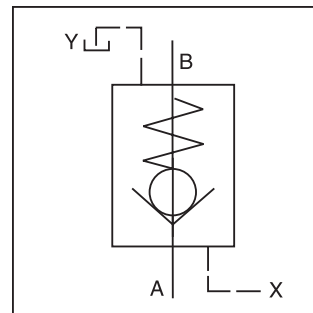

### Specifications

General			
Size	NG10	NG25	NG32
Suplute Mounting	ISO 5781		
Mounting Position	Unrestricted		
Ambient Temperature Range	-20°C to +80°C (-4°F to +176°F)		
Hydraulic			
Maximum Operating Pressure	350 Bar (5075 PSI)		
Nominal Flow	150 LPM (39.7 GPM)	270 LPM (71.4 GPM)	450 LPM (119.0 GPM)
Fluid	Hydraulic oil to DIN 51524		
Viscosity	Recommended	30 to 50 cSt (mm <sup>2</sup> /s)	
	Permitted	20 to 380 cSt (mm <sup>2</sup> /s)	
Fluid Temperature	Recommended	+30°C to +50°C (86°F to +122°F)	
	Permitted	-20°C to +70°C (-4°F to +158°F)	
Filtration	ISO Class 4406 (1999) 18/16/13		

**Ordering Information**

<div style="border: 1px solid black; width: 30px; height: 30px; margin: 0 auto;"></div> <p>Seals</p>	<div style="border: 1px solid black; padding: 2px; width: 50px; margin: 0 auto;"><b>SVL</b></div> <p>Hydr. Pilot Operated Check Valve</p>	<div style="border: 1px solid black; width: 30px; height: 30px; margin: 0 auto;"></div> <p><b>E</b></p> <p>Subplate Mounting</p>	<div style="border: 1px solid black; padding: 2px; width: 50px; margin: 0 auto;"><b>LR</b></div> <p>External Drain Port Y1 (G1/4")</p>	<div style="border: 1px solid black; padding: 2px; width: 50px; margin: 0 auto;"><b>5</b></div> <p>Design Style to ISO 5781</p>	<div style="border: 1px solid black; padding: 2px; width: 50px; margin: 0 auto;"><b>4</b></div> <p>Poppet Type 04</p>	<div style="border: 1px solid black; width: 30px; height: 30px; margin: 0 auto;"></div> <p>Pilot Control Ratio</p>	<div style="border: 1px solid black; width: 30px; height: 30px; margin: 0 auto;"></div> <p>Nominal Size</p>	<div style="border: 1px solid black; width: 30px; height: 30px; margin: 0 auto;"></div> <p>Closing Spring</p>	<div style="border: 1px dashed black; width: 30px; height: 30px; margin: 0 auto;"></div> <p>Design Series</p> <p>NOTE: Not required when ordering</p>
--	---	--	--	---	---	--	---	---	---

Code	Description
Omit	Nitrile
V	Fluorocarbon

Code	Description
P10	NG10
P25	NG25
P32	NG32

Code	Description
1	1:1
3	3:1
8	8:1
9	10:1

Code	Description
N	0.5 Bar (7.25 PSI)
R	1.0 Bar (14.5 PSI)
T	2.0 Bar (29 PSI)
U	4.0 Bar (58 PSI)

**Weight:**

SVLE*P10	2.8 kg (6.2 lbs.)
SVLE*P25	4.6 kg (10.1 lbs.)
SVLE*P32	6.1 kg (13.5 lbs.)

**Performance Curve**

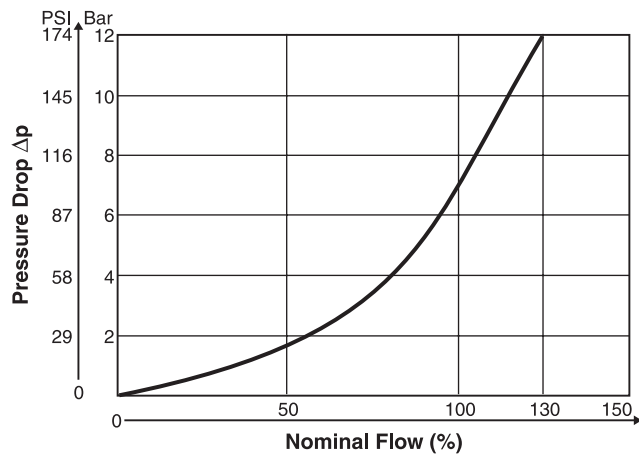

**Dimensions**

**Pilot Operated Check Valve  
Series SVLE**

Inch equivalents for millimeter dimensions are shown in (\*\*)

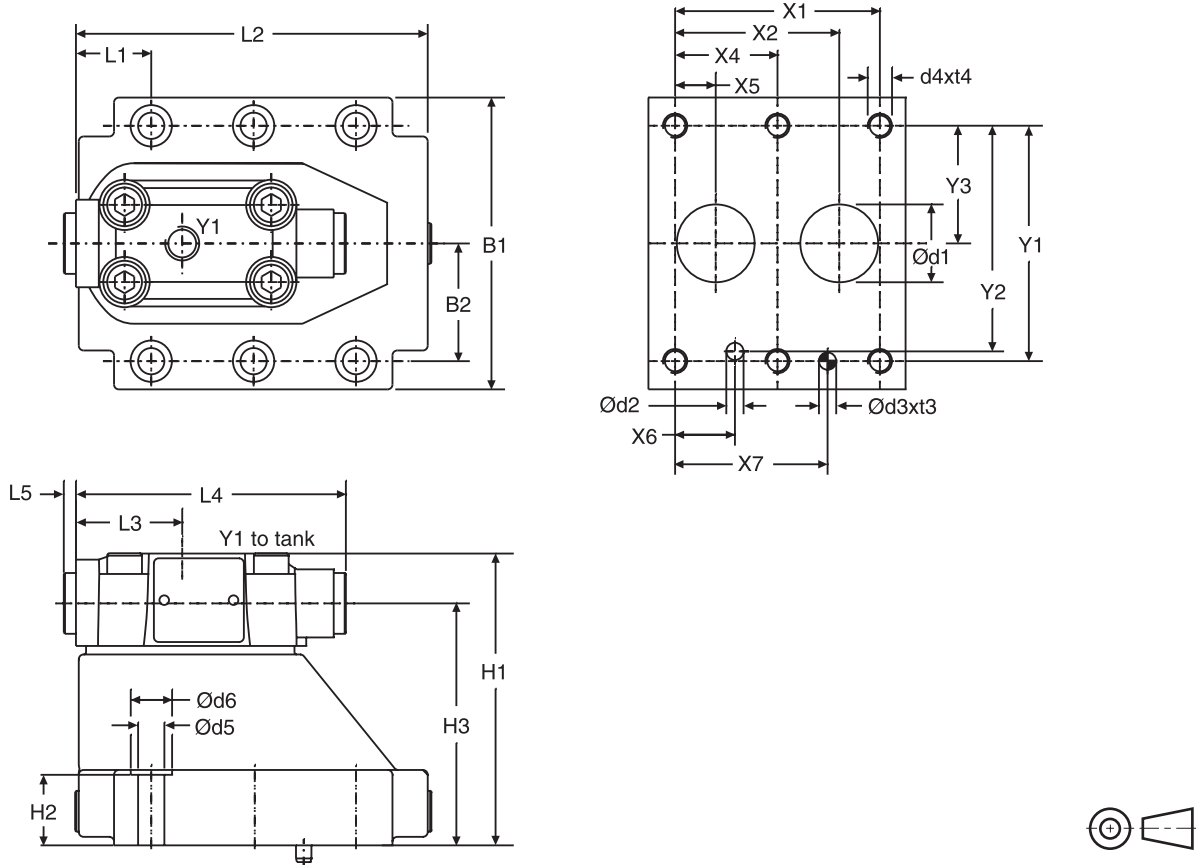

NG	ISO-code	x1	x2	x3	x4	x5	x6	x7	y1	y2	y3	y4	y5	y6
10	5781-06-07-0-00	42.9 (1.69)	35.8 (1.41)	-	-	7.2 (0.28)	21.5 (0.85)	31.8 (1.25)	66.7 (2.63)	58.8 (2.31)	33.4 (1.31)	-	-	-
25	5781-08-10-0-00	60.3 (2.37)	49.2 (1.94)	-	-	11.1 (0.44)	20.6 (0.81)	44.5 (1.75)	79.4 (3.13)	73.0 (2.87)	39.7 (1.56)	-	-	-
32	5781-10-13-0-00	84.2 (3.31)	67.5 (2.66)	-	42.1 (1.66)	16.7 (0.66)	24.6 (0.97)	62.7 (2.47)	96.8 (3.81)	92.8 (3.65)	48.4 (1.91)	-	-	-

Tolerance for all dimensions ±0.2 mm (0.01 inches)

NG	ISO-code	B1	B2	H1	H2	H3	H4	H5	H6	L1	L2	L3	L4	L5	L6
10	5781-06-07-0-00	87.3 (3.44)	33.4 (1.31)	83.0 (3.27)	21.0 (0.83)	62.5 (2.46)	-	-	-	29.4 (1.16)	95.2 (3.75)	43.7 (1.72)	111.0 (4.37)	5.0 (0.20)	-
25	5781-08-10-0-00	105 (4.13)	39.7 (1.56)	109.5 (4.31)	29.0 (1.14)	89.0 (3.50)	-	-	-	35.1 (1.38)	127.2 (5.01)	43.7 (1.72)	111.0 (4.37)	5.0 (0.20)	-
32	5781-10-13-0-00	120 (4.72)	48.4 (1.91)	120.0 (4.72)	29.0 (1.14)	99.5 (3.92)	-	-	-	31.0 (1.22)	144.7 (5.70)	43.7 (1.72)	111.0 (4.37)	5.0 (0.20)	-

NG	ISO-code	d1max	d2max	d3	t3	d4	t4	d5	d6
10	5781-06-07-0-00	15.0 (0.59)	7.0 (0.28)	7.1 (0.28)	8.0 (0.31)	M10	16.0 (0.63)	10.8 (0.43)	17.0 (0.67)
25	5781-08-10-0-00	23.4 (0.92)	7.1 (0.28)	7.1 (0.28)	8.0 (0.31)	M10	18.0 (0.71)	10.8 (0.43)	17.0 (0.67)
32	5781-10-13-0-00	32.0 (1.26)	7.1 (0.28)	7.1 (0.28)	8.0 (0.31)	M10	20.0 (0.79)	10.8 (0.43)	17.0 (0.67)

NG	ISO-code	Kit		Kit		Surface finish
10	5781-06-07-0-00	BK-M10 x 35-4pcs	68 Nm (50.2 lb-ft)	SK-SVLE5P10	SK-SVLE5P10V	
25	5781-08-10-0-00	BK-M10 x 45-4pcs	68 Nm (50.2 lb-ft)	SK-SVLE5P25	SK-SVLE5P25V	
32	5781-10-13-0-00	BK-M10 x 45-6pcs	68 Nm (50.2 lb-ft)	SK-SVLE5P32	SK-SVLE5P32V	

SVLE.indd, dd

**General Description**

Series R pressure relief valves consist of a manual adjustment pilot stage and a cartridge main stage.

Series RS pressure relief valves consist of a manual adjusted pilot stage with a directional valve for an electrically controlled vent function and a cartridge main part.

**Features**

- Pilot operated with manual adjustment.
- 3 interfaces
  - Subplate, ISO 6264 (DIN 24340 Form D + Form E)
  - Slip-in, ISO 7368
- 4 pressure ranges.
- 2 switching types (series RS).
- 3 adjustment modes
  - Screw with lock nut
  - Hand knob
  - DIN lock
- Remote control via port X.

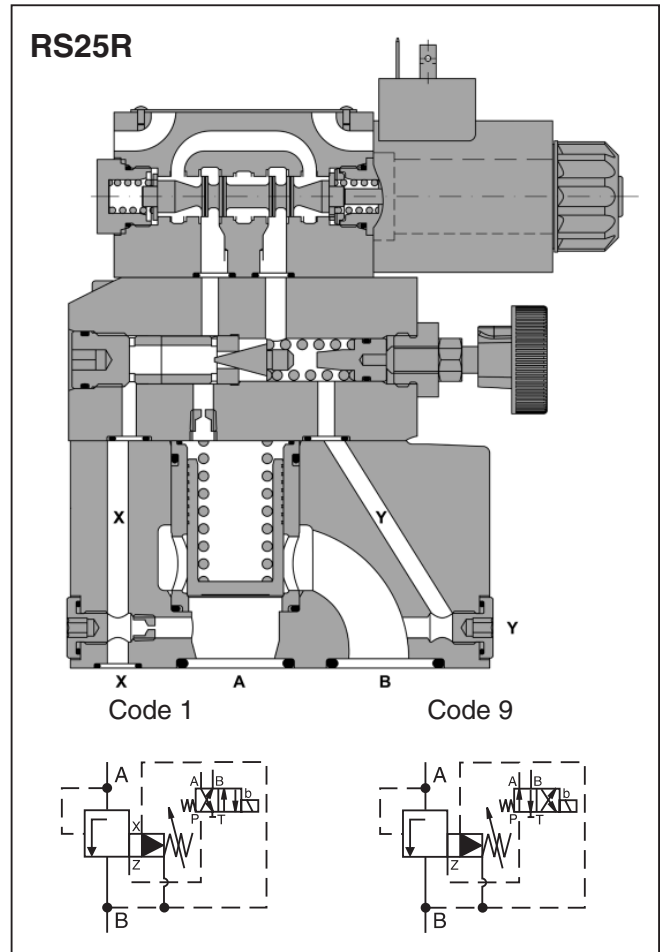
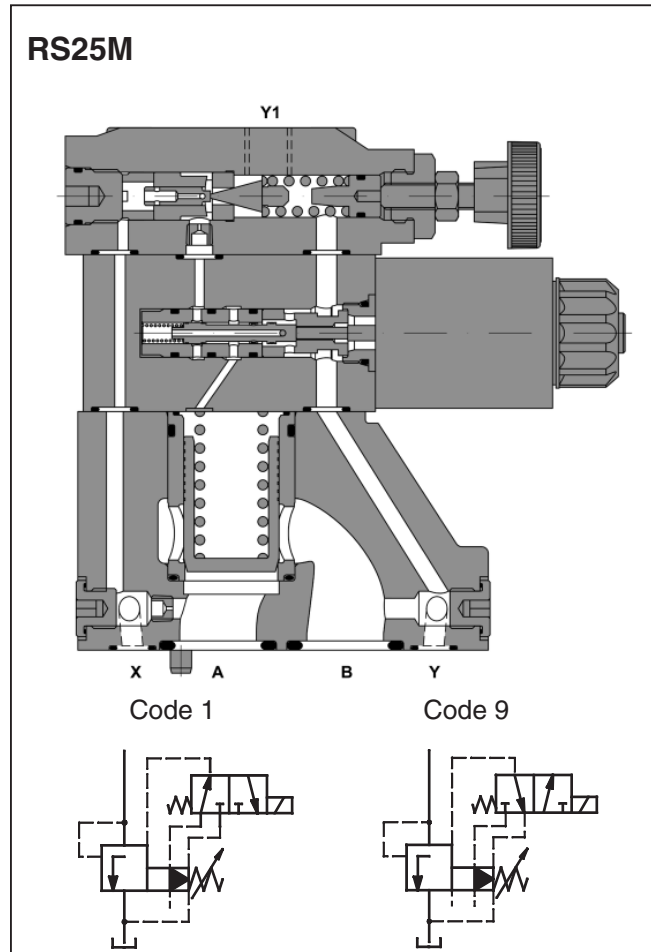
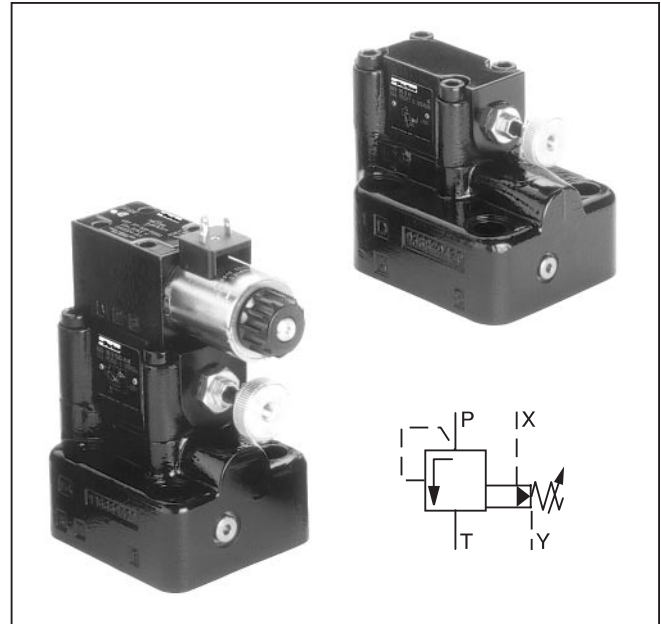

RS\_R RS\_M.indd, dd

## R\*R and R\*M

General				
Size		NG10	NG25	NG32
Interface	Subplate mounting acc. ISO 6264			
Mounting Position	As desired, horizontal mounting preferred			
Ambient Temperature	-20°C to +80°C (-4°F to +176°F)			
Hydraulic				
Operating Pressure	Ports P or A and X up to 350 Bar (5075 PSI), connection T or B and Y depressurized			
Pressure Range	75, 175, 250, 350 Bar (1088, 2538, 3625, 5075 PSI)			
Nominal Flow	Series R*R LPM (GPM)	250 (66.1)	500 (132.3)	650 (172.0)
	Series R*M LPM (GPM)	150 (39.7)	350 (92.6)	650 (172.0)
Pressure Fluid	Hydraulic oil according to DIN 51524 ... 525			
Viscosity	Recommended Maximum	30 to 50 cSt (mm <sup>2</sup> /s) 20 to 380 cSt (mm <sup>2</sup> /s)		
Pressure Fluid Temperature	Recommended Maximum	+30°C to +50°C (+86°F to +122°F) -20°C to +70° (-4°F to +158°F)		
Filtration	ISO 4406 (1999), 18/16/13			

## RS\*R and RS\*M

General				
Size		NG10	NG25	NG32
Interface	Subplate mounting acc. ISO 6264			
Mounting Position	As desired, horizontal mounting preferred			
Ambient Temperature	-20°C to +80°C (-4°F to +176°F)			
Hydraulic				
Operating Pressure	Ports P or A and X up to 350 Bar (5075 PSI), connection T or B and Y depressurized			
Pressure Range	75, 175, 250, 350 Bar (1088, 2538, 3625, 5075 PSI)			
Nominal Flow	Series RS*R LPM (GPM)	250 (66.1)	500 (132.3)	650 (172.0)
	Series RS*M LPM (GPM)	150 (39.7)	350 (92.6)	650 (172.0)
Pressure Fluid	Hydraulic oil according to DIN 51524 ... 525			
Viscosity	Recommended Maximum	30 to 50 cSt (mm <sup>2</sup> /s) 20 to 380 cSt (mm <sup>2</sup> /s)		
Pressure Fluid Temperature	Recommended Maximum	+30°C to +50°C (+86°F to +122°F) -20°C to +70° (-4°F to +158°F)		
Filtration	ISO 4406 (1999), 18/16/13			
Electrical (solenoid)				
Duty Cycle	100% ED			
Plug Connectors	2pole + PE / connector acc. to EN 175301-803			
Protection Class	IP54 at DIN 40050 (plugged and mounted)			
Supply Voltage	Volt	Code	Power (W)	Current (A)
	12	K	31	2.5
	24	J		1.25
	98	U		0.31
	198	G		0.15
Response Time	Energized / de-energized 32/40 ms			
Switching Frequency	Max. 15,000 switchings/hour			



<div style="border: 1px solid black; padding: 2px; width: 20px; margin: 0 auto;">R</div> Pressure Relief Valve	<div style="border: 1px solid black; width: 20px; height: 20px; margin: 0 auto;"></div> Size	<div style="border: 1px solid black; width: 20px; height: 20px; margin: 0 auto;"></div> Interface	<div style="border: 1px solid black; width: 20px; height: 20px; margin: 0 auto;"></div> Pressure Range	<div style="border: 1px solid black; width: 20px; height: 20px; margin: 0 auto;"></div> Adjustment	<div style="border: 1px solid black; width: 20px; height: 20px; margin: 0 auto;"></div> Pilot Oil	<div style="border: 1px solid black; padding: 2px; width: 20px; margin: 0 auto;">S</div> Poppet Spring	<div style="border: 1px solid black; width: 20px; height: 20px; margin: 0 auto;"></div> Seals	<div style="border: 1px dashed black; width: 20px; height: 20px; margin: 0 auto;"></div> Design Series NOTE: Not required when ordering.
--	--	---	--	--	---	--	---	--

Code	Description
07	70 Bar (1015 PSI)
17	175 Bar (2538 PSI)
25	250 Bar (3625 PSI)
35	350 Bar (5075 PSI)

Code	Description
N	Nitrile
V	Fluorocarbon

Code	Pilot	Drain
1	Internal	External
4	Internal	Internal

Code	Size	Mounting
10	NG10	Subplate mounting
25	NG25	mounting
32	NG32	

Code	Description
L	DIN lock
S	Hand knob

Code	Interface
R <sup>1)</sup>	Subplate mounting ISO 6264
M	NG 10; 25; 32 NG 10 and 25 NG 32

<sup>1)</sup> external drain with pipe only

**Weight:**

R10R	4.5 kg	(9.9 lbs.)
R25R	5.8 kg	(12.8 lbs.)
R32R	7.8 kg	(17.2 lbs.)
R10M	2.7 kg	(6.0 lbs.)
R25M	4.5 kg	(9.9 lbs.)
R32M	6.0 kg	(13.2 lbs.)

<b>RS</b>	□	□	□	□	□	<b>S</b>	□	□	□	<b>W</b>	□
Pressure Relief Valve with Unloading	Size	Interface	Pressure Range	Adjustment	Pilot Oil	Poppet Spring	Seals	Switching Type	Solenoid	Without Plug	Options

Code	Description
07	70 Bar (1015 PSI)
17	175 Bar (2538 PSI)
25	250 Bar (3625 PSI)
35	350 Bar (5075 PSI)

Code	Description
Omit	Standard
S	With slow unloading

Code	Description
N	Nitrile
V	Fluorocarbon

Code	Description *
K	12V
J	24V
U	102V
G	105V

\* Use plug with rectifier at AC

Code	Description
1 *	Solenoid not activated unpress. circulation
9 *	Solenoid activated unpress. circulation

\* Detailed symbols see page 21

  

Code	Pilot	Drain
1	Internal	External
4	Internal	Internal

Code	Description
L	DIN lock
S	Hand knob

Code	Interface
R <sup>1)</sup>	Subplate mounting ISO 6264 
M	

<sup>1)</sup> external drain with pipe only

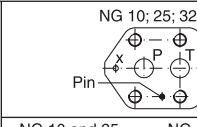
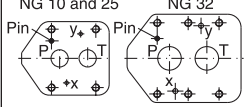

Code	Size	Mounting
10	NG10	Subplate mounting
25	NG25	mounting
32	NG32	

**Weight:**

RS10R	5.9 kg	(13.0 lbs.)
RS25R	7.2 kg	(15.9 lbs.)
RS32R	9.2 kg	(20.3 lbs.)
RS10M	4.4 kg	(9.7 lbs.)
RS25M	6.2 kg	(13.7 lbs.)
RS32M	7.7 kg	(17.0 lbs.)

**R\*R and RS\*R <sup>1)</sup>**

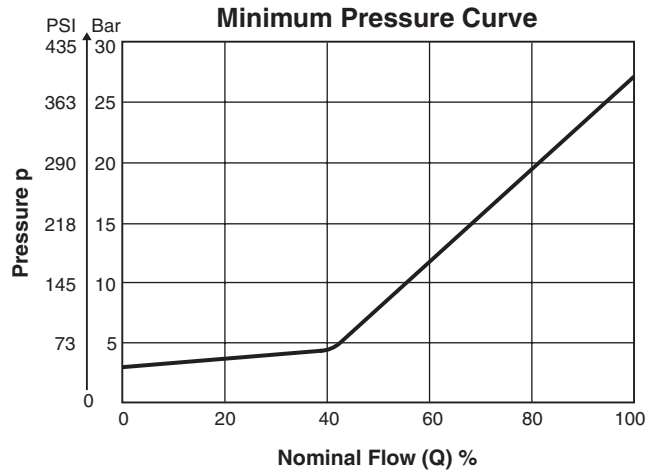
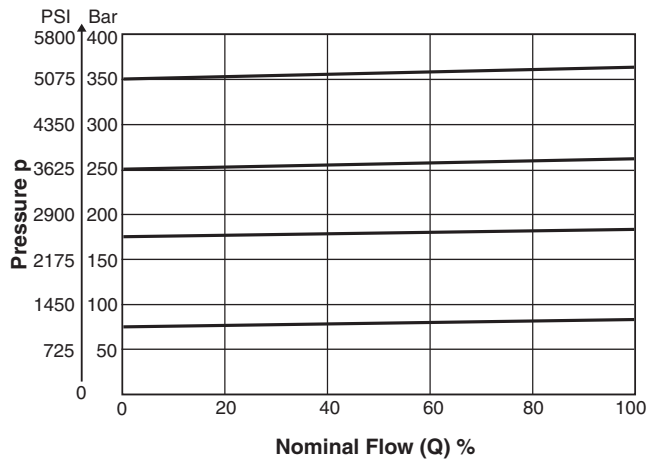

**R\*M and RS\*M <sup>1)</sup>**

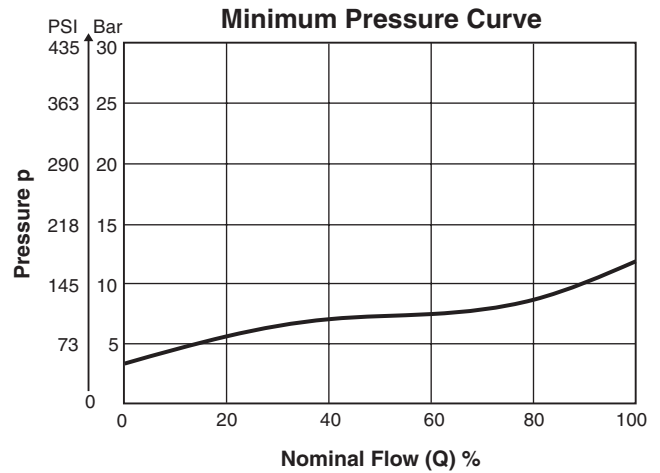
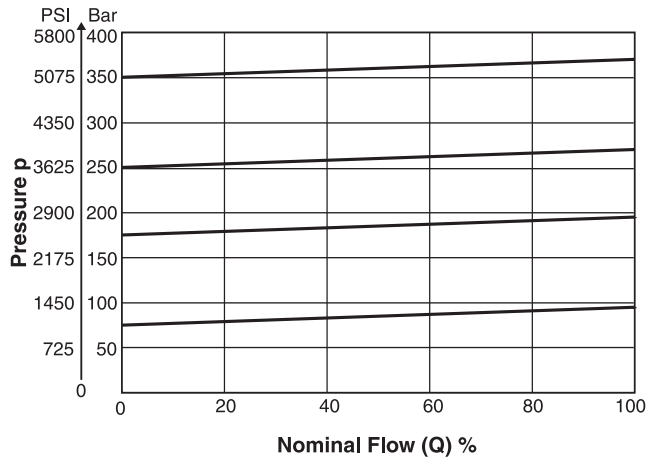

<sup>1)</sup> The performance curves are measured with external drain.  
 For internal drain the tank pressure has to be added to curve.

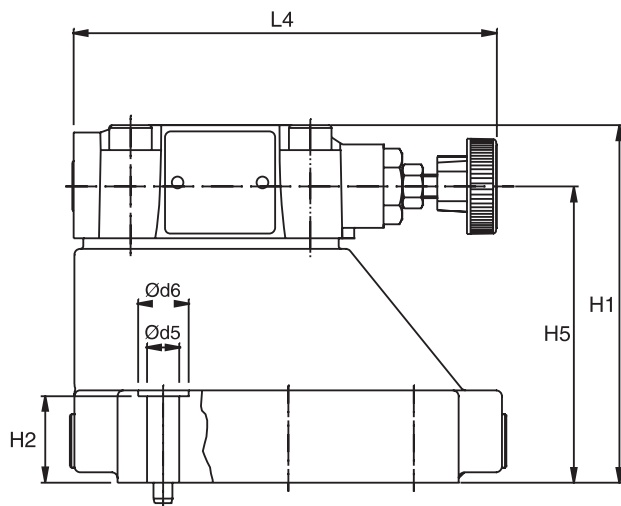
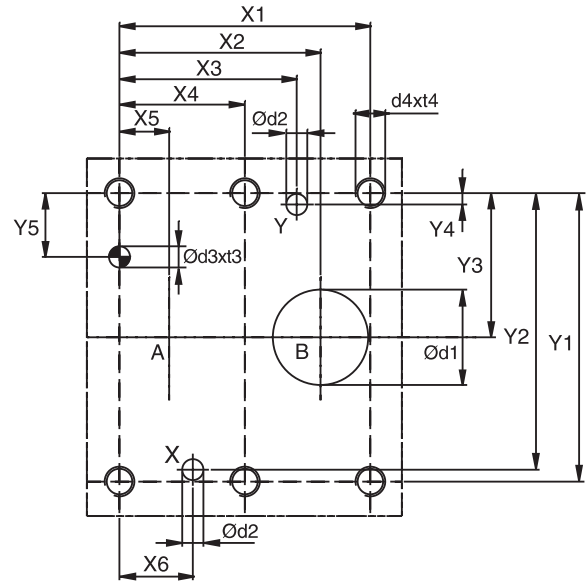
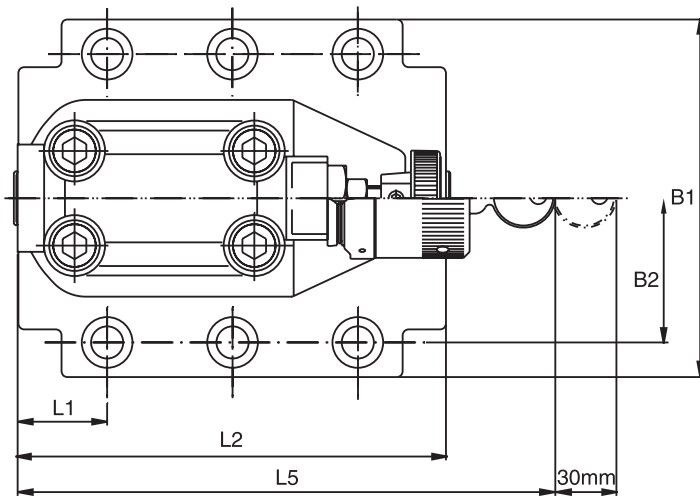

**Dimensions**

**Pilot Operated Pressure Relief Valve  
Series R\*M**



Inch equivalents for millimeter dimensions are shown in (\*\*)

NG	ISO-code	x1	x2	x3	x4	x5	x6	x7	y1	y2	y3	y4	y5	y6
10	6264-06-09-* <sup>-97</sup>	42.9 (1.69)	35.8 (1.41)	21.5 (0.85)	– –	7.2 (0.28)	21.5 (0.85)	0.0 (0.00)	66.7 (2.63)	58.8 (2.31)	33.4 (1.31)	7.9 (0.31)	14.3 (0.56)	– –
25	6264-08-13-* <sup>-97</sup>	60.3 (2.37)	49.2 (1.94)	39.7 (1.56)	– –	11.1 (0.44)	20.6 (0.81)	0.0 (0.00)	79.4 (3.13)	73.0 (2.87)	39.7 (1.56)	6.4 (0.25)	15.9 (0.63)	– –
32	6264-10-17-* <sup>-97</sup>	84.2 (3.31)	67.5 (2.66)	59.5 (2.34)	42.1 (1.66)	16.7 (0.66)	24.6 (0.97)	0.0 (0.00)	96.8 (3.81)	92.8 (3.65)	48.4 (1.91)	3.8 (0.15)	21.4 (0.84)	– –

Tolerance at X and Y pin holes and screw holes ±0.1, at port holes ±0.2.

NG	ISO-code	B1	B2	H1	H2	H3	H4	H5	H6	L1	L2	L3	L4	L5	L6
10	6264-06-09-* <sup>-97</sup>	87.3 (3.44)	33.4 (1.31)	83.0 (3.27)	21.0 (0.83)	– –	– –	62.5 (2.46)	– –	29.0 (1.14)	94.8 (3.73)	– –	141.0 (5.55)	181.0 (7.13)	– –
25	6264-08-13-* <sup>-97</sup>	105.0 (4.13)	39.7 (1.56)	109.5 (4.31)	29.0 (1.14)	– –	– –	89.0 (3.50)	– –	34.7 (1.37)	126.8 (4.99)	– –	141.0 (5.55)	181.0 (7.13)	– –
32	6264-10-17-* <sup>-97</sup>	120.0 (4.72)	48.4 (1.91)	120.0 (4.72)	29.0 (1.14)	– –	– –	99.5 (3.92)	– –	30.6 (1.20)	144.3 (5.68)	– –	141.0 (5.55)	181.0 (7.13)	– –

NG	ISO-code	d1max	d2max	d3	t3	d4	t4	d5	d6
10	6264-06-09-* <sup>-97</sup>	15.0 (0.59)	7.0 (0.28)	7.1 (0.28)	8.0 (0.31)	M10	16.0 (0.63)	10.8 (0.43)	17.0 (0.67)
25	6264-08-13-* <sup>-97</sup>	23.4 (0.92)	7.1 (0.28)	7.1 (0.28)	8.0 (0.31)	M10	18.0 (0.71)	10.8 (0.43)	17.0 (0.67)
32	6264-10-17-* <sup>-97</sup>	32.0 (1.26)	7.1 (0.28)	7.1 (0.28)	8.0 (0.31)	M10	20.0 (0.79)	10.8 (0.43)	17.0 (0.67)

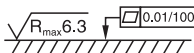
NG	ISO-code	Bolt kit -  DIN912 12.9		NBR  Kit	FPM	Surface finish
10	6264-06-09-* <sup>-97</sup>	BK-M10 x 35-4pcs	63 Nm (46.5 lb.-ft.)	SK-R10MN50	SK-R10MV50	
25	6264-08-13-* <sup>-97</sup>	BK-M10 x 45-4pcs	63 Nm (46.5 lb.-ft.)	SK-R25MN50	SK-R25MV50	
32	6264-10-17-* <sup>-97</sup>	BK-M10 x 45-6pcs	63 Nm (46.5 lb.-ft.)	SK-R32MN50	SK-R32MV50	

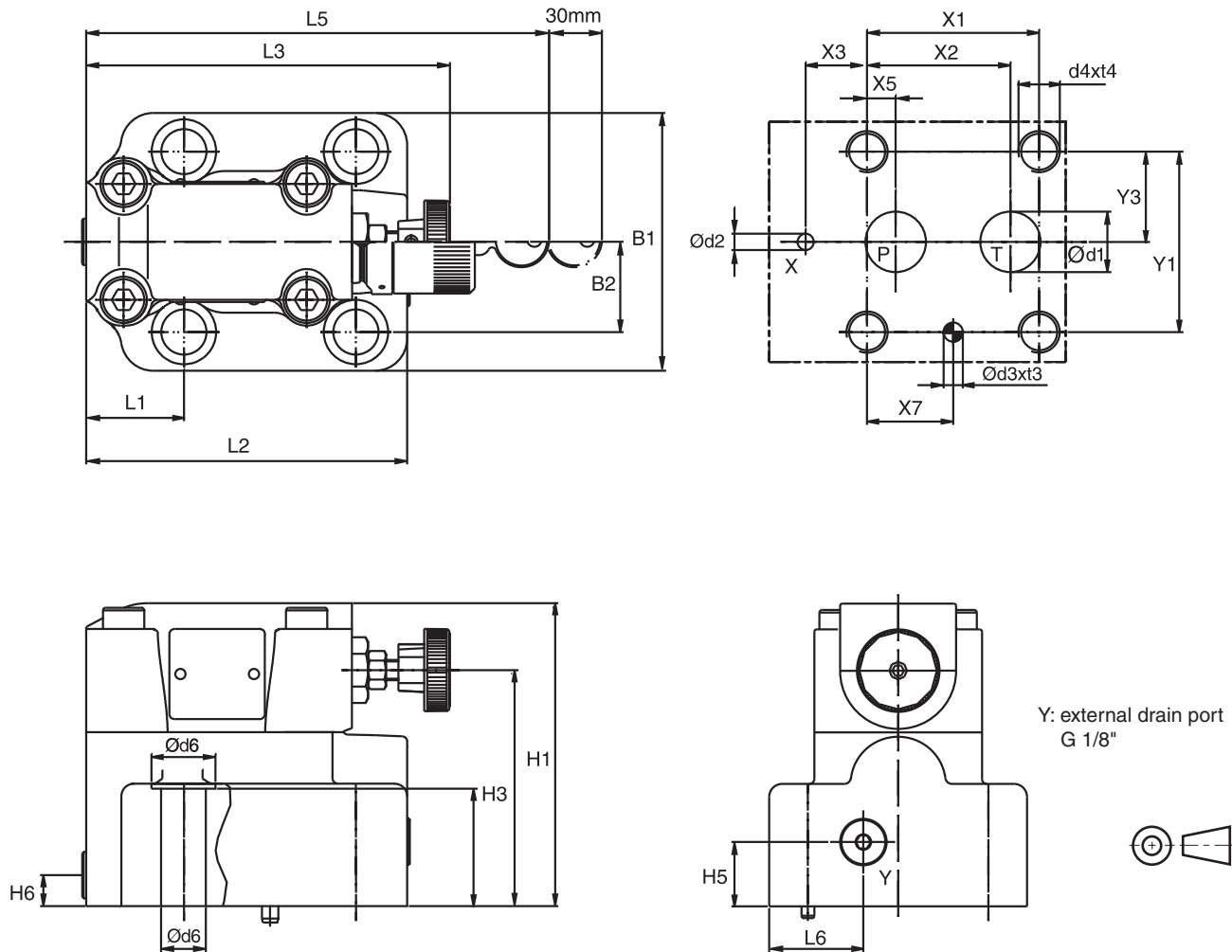

**Dimensions**

**Pilot Operated Pressure Relief Valve  
Series R\*R**



Inch equivalents for millimeter dimensions are shown in (\*\*)

NG	ISO-code	x1	x2	x3	x4	x5	x6	x7	y1	y2	y3	y4	y5	y6
10	6264-06-09-*-97	53.8 (2.12)	47.5 (1.87)	0.0 (0.00)	–	22.1 (0.87)	–	22.1 (0.87)	53.8 (2.12)	–	26.9 (1.06)	–	–	–
25	6264-08-13-*-97	66.7 (2.63)	55.6 (2.19)	23.8 (0.94)	–	11.1 (0.44)	–	33.4 (1.31)	70.0 (2.76)	–	35.0 (1.38)	–	–	–
32	6264-10-17-*-97	88.9 (3.50)	76.2 (3.00)	31.8 (1.25)	–	12.7 (0.50)	–	44.5 (1.75)	82.6 (3.25)	–	41.3 (1.63)	–	–	–

Tolerance at X and Y pin holes and screw holes ±0.1, at port holes ±0.2.

NG	ISO-code	B1	B2	H1	H2	H3	H4	H5	H6	L1	L2	L3	L4	L5	L6
10	6264-06-09-*-97	80.0 (3.15)	26.9 (1.06)	114.0 (4.49)	27.0 (1.06)	88.0 (3.46)	–	25.0 (0.98)	12.0 (0.47)	52.5 (2.07)	118.5 (4.67)	141.0 (5.55)	–	180.0 (7.09)	36.5 (1.44)
25	6264-08-13-*-97	100.0 (3.94)	35.0 (1.38)	117.5 (4.63)	45.5 (1.79)	91.5 (3.60)	–	25.0 (0.98)	12.0 (0.47)	37.9 (1.49)	124.5 (4.90)	141.0 (5.55)	–	180.0 (7.09)	36.5 (1.44)
32	6264-10-17-*-97	120.0 (4.72)	41.3 (1.63)	123.0 (4.83)	52.0 (2.05)	97.0 (3.82)	–	25.0 (0.98)	12.0 (0.47)	45.0 (1.77)	153.0 (6.02)	141.0 (5.55)	–	180.0 (7.09)	36.5 (1.44)

NG	ISO-code	d1max	d2max	d3	t3	d4	t4	d5	d6
10	6264-06-09-*-97	14.7 (0.58)	4.8 (0.19)	7.5 (0.30)	10.0 (0.39)	M12	20.0 (0.79)	13.5 (0.53)	20.0 (0.79)
25	6264-08-13-*-97	23.4 (0.92)	6.3 (0.25)	7.5 (0.30)	10.0 (0.39)	M16	27.0 (1.06)	17.5 (0.69)	25.0 (0.98)
32	6264-10-17-*-97	32.0 (1.26)	6.3 (0.25)	7.5 (0.30)	10.0 (0.39)	M18	28.0 (1.10)	20.0 (0.79)	30.0 (1.18)

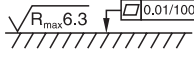
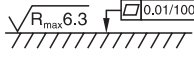
NG	ISO-code	Bolt kit -  DIN912 12.9		NBR  Kit	FPM	Surface finish 
10	6264-06-09-*-97	BK-M12 x 45-4pcs	108 Nm ±15% (79.6 lb.-ft.)	SK-R10RN50	SK-R10RV50	
25	6264-08-13-*-97	BK-M16 x 70-4pcs	264 Nm ±15% (194.7 lb.-ft.)	SK-R25RN50	SK-R25RV50	
32	6264-10-17-*-97	BK-M18 x 75-4pcs	398 Nm ±15% (293.5 lb.-ft.)	SK-R32RN50	SK-R32RV50	



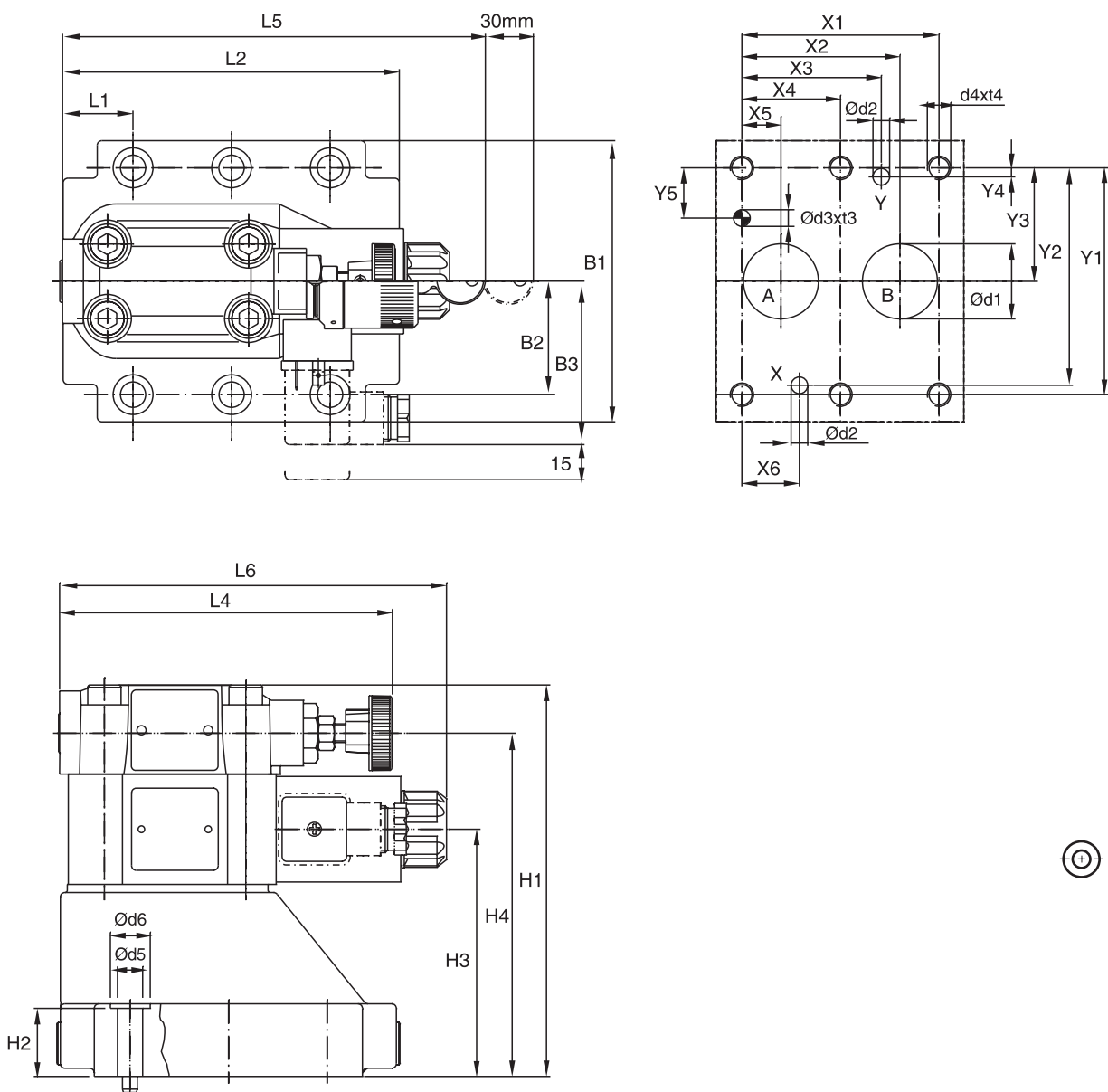

**Dimensions**

**Pilot Operated Pressure Relief Valve  
Series RS\*M**



Inch equivalents for millimeter dimensions are shown in (\*\*)

NG	ISO-code	x1	x2	x3	x4	x5	x6	x7	y1	y2	y3	y4	y5	y6
10	6264-06-09-*-97	42.9 (1.69)	35.8 (1.41)	21.5 (0.85)	– –	7.2 (0.28)	21.5 (0.85)	0.0 (0.00)	66.7 (2.63)	58.8 (2.31)	33.4 (1.31)	7.9 (0.31)	14.3 (0.56)	– –
25	6264-08-13-*-97	60.3 (2.37)	49.2 (1.94)	39.7 (1.56)	– –	11.1 (0.44)	20.6 (0.81)	0.0 (0.00)	79.4 (3.13)	73.0 (2.87)	39.7 (1.56)	6.4 (0.25)	15.9 (0.63)	– –
32	6264-10-17-*-97	84.2 (3.31)	67.5 (2.66)	59.5 (2.34)	42.1 (1.66)	16.7 (0.66)	24.6 (0.97)	0.0 (0.00)	96.8 (3.81)	92.8 (3.65)	48.4 (1.91)	3.8 (0.15)	21.4 (0.84)	– –

Tolerance at X and Y pin holes and screw holes ±0.1, at port holes ±0.2.

NG	ISO-code	B1	B2	B3	H1	H2	H3	H4	H6	L1	L2	L3	L4	L5	L6
10	6264-06-09-*-97	87.3 (3.44)	33.4 (1.31)	70.0 (2.76)	130.0 (5.12)	21.0 (0.83)	68.5 (2.70)	109.5 (4.31)	– –	29.0 (1.14)	94.8 (3.73)	– –	141.0 (5.55)	181.0 (7.13)	165.6 (6.52)
25	6264-08-13-*-97	105.0 (4.13)	39.7 (1.59)	70.0 (2.76)	156.5 (6.16)	29.0 (1.14)	95.0 (3.74)	136.0 (5.35)	– –	34.7 (1.37)	126.8 (4.99)	– –	141.0 (5.55)	181.0 (7.13)	165.6 (6.52)
32	6264-10-17-*-97	120.0 (4.72)	48.4 (1.91)	70.0 (2.76)	167.0 (6.57)	29.0 (1.14)	105.5 (4.15)	146.5 (5.77)	– –	30.6 (1.20)	144.3 (5.68)	– –	141.0 (5.55)	181.0 (7.13)	165.6 (6.52)

NG	ISO-code	d1max	d2max	d3	t3	d4	t4	d5	d6
10	6264-06-09-*-97	15.0 (0.59)	7.0 (0.28)	7.1 (0.28)	8.0 (0.31)	M10	16.0 (0.63)	10.8 (0.43)	17.0 (0.67)
25	6264-08-13-*-97	23.4 (0.92)	7.1 (0.28)	7.1 (0.28)	8.0 (0.31)	M10	18.0 (0.71)	10.8 (0.43)	17.0 (0.67)
32	6264-10-17-*-97	32.0 (1.26)	7.1 (0.28)	7.1 (0.28)	8.0 (0.31)	M10	20.0 (0.79)	10.8 (0.43)	17.0 (0.67)

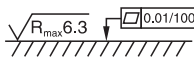
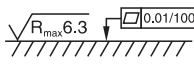
NG	ISO-code	Bolt kit -  DIN912 12.9		NBR  Kit FPM	Surface finish 
10	6264-06-09-*-97	BK-M10 x 35-4pcs	63 Nm (46.5 lb.-ft.)	SK-RS10MN50   SK-RS10MV50	
25	6264-08-13-*-97	BK-M10 x 45-4pcs	63 Nm (46.5 lb.-ft.)	SK-RS25MN50   SK-RS25MV50	
32	6264-10-17-*-97	BK-M10 x 45-6pcs	63 Nm (46.5 lb.-ft.)	SK-RS32MN50   SK-RS32MV50	

**Dimensions**

**Pilot Operated Pressure Relief Valve  
Series RS\*R**

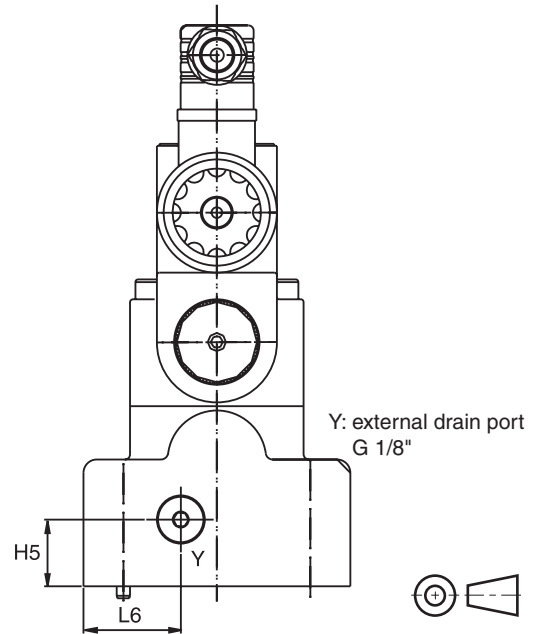
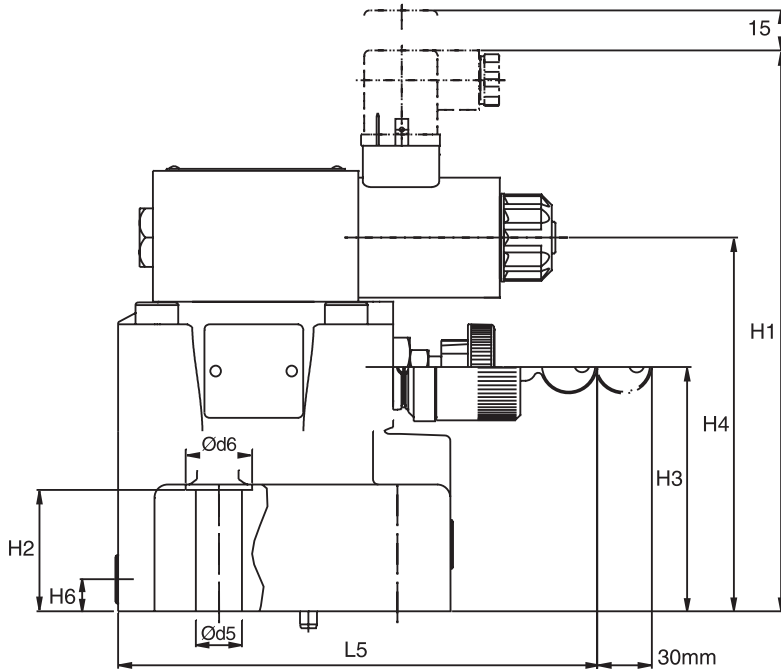
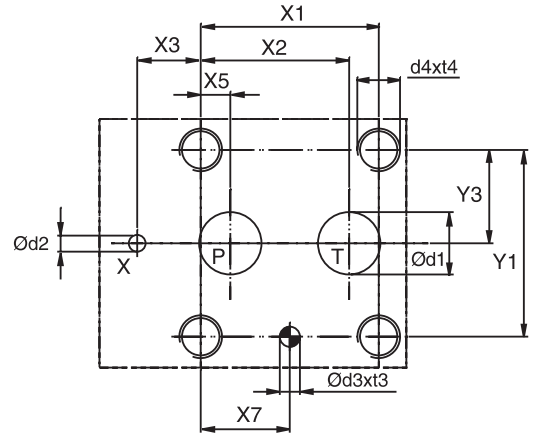
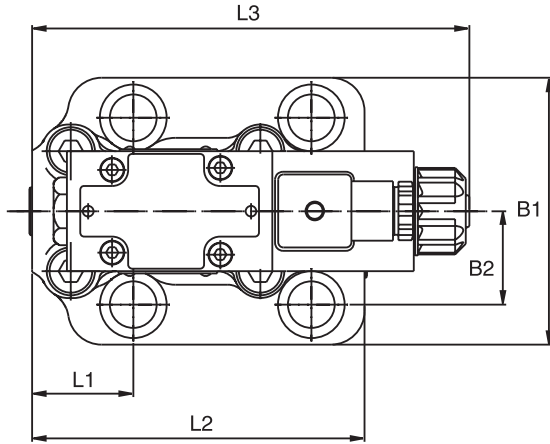

**Dimensions**

**Pilot Operated Pressure Relief Valve  
Series RS\*R**



Inch equivalents for millimeter dimensions are shown in (\*\*)

NG	ISO-code	x1	x2	x3	x4	x5	x6	x7	y1	y2	y3	y4	y5	y6
10	6264-06-09-* <sup>-97</sup>	53.8 (2.12)	47.5 (1.87)	0.0 (0.00)	– –	22.1 (0.87)	– –	22.1 (0.87)	53.8 (2.12)	– –	26.9 (1.06)	– –	– –	– –
25	6264-08-13-* <sup>-97</sup>	66.7 (2.63)	55.6 (2.19)	23.8 (0.91)	– –	11.1 (0.44)	– –	33.4 (1.31)	70.0 (2.76)	– –	35.0 (1.38)	– –	– –	– –
32	6264-10-17-* <sup>-97</sup>	88.9 (3.50)	76.2 (3.00)	31.8 (1.25)	– –	12.7 (0.50)	– –	44.5 (1.75)	82.6 (3.25)	– –	41.3 (1.63)	– –	– –	– –

Tolerance at X and Y pin holes and screw holes ±0.1, at port holes ±0.2.

NG	ISO-code	B1	B2	H1	H2	H3	H4	H5	H6	L1	L2	L3	L4	L5	L6
10	6264-06-09-* <sup>-97</sup>	80.0 (3.15)	26.9 (1.06)	206.0 (8.11)	27.0 (1.06)	88.0 (3.46)	136.5 (5.37)	25.0 (0.98)	12.0 (0.47)	52.5 (2.07)	118.5 (4.67)	163.8 (6.45)		180.0 (7.09)	36.5 (1.44)
25	6264-08-13-* <sup>-97</sup>	100.0 (3.94)	35.0 (1.38)	210.0 (8.27)	45.5 (1.79)	91.5 (3.60)	140.0 (5.51)	25.0 (0.98)	12.0 (0.47)	37.9 (1.49)	124.5 (4.90)	163.8 (6.45)	–	180.0 (7.09)	36.5 (1.44)
32	6264-10-17-* <sup>-97</sup>	120.0 (4.72)	41.3 (1.63)	215.5 (8.48)	52.0 (2.05)	97.0 (3.82)	145.5 (5.73)	25.0 (0.98)	12.0 (0.47)	45.0 (1.77)	153 (6.02)	163.8 (6.45)		180.0 (7.09)	36.5 (1.44)

NG	ISO-code	d1max	d2max	d3	t3	d4	t4	d5	d6
10	6264-06-09-* <sup>-97</sup>	14.7 (0.58)	4.8 (0.19)	7.5 (0.30)	10.0 (0.39)	M12	20.0 (0.79)	13.5 (0.53)	20.0 (0.79)
25	6264-08-13-* <sup>-97</sup>	23.4 (0.92)	6.3 (0.25)	7.5 (0.30)	10.0 (0.39)	M16	27.0 (1.06)	17.5 (0.69)	25.0 (0.98)
32	6264-10-17-* <sup>-97</sup>	32.0 (1.26)	6.3 (0.25)	7.5 (0.30)	10.0 (0.39)	M18	28.0 (1.10)	20.0 (0.79)	30.0 (1.18)

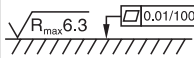
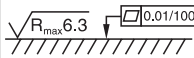
NG	ISO-code	Bolt kit -  DIN912 12.9		NBR  Kit FPM	Surface finish 
10	6264-06-09-* <sup>-97</sup>	BK-M12 x 45-4pcs	108 Nm ±15% (79.6 lb.-ft.)	SK-RS10RN50   SK-RS10RV50	
25	6264-08-13-* <sup>-97</sup>	BK-M16 x 70-4pcs	264 Nm ±15% (194.7 lb.-ft.)	SK-RS25RN50   SK-RS25RV50	
32	6264-10-17-* <sup>-97</sup>	BK-M18 x 75-4pcs	398 Nm ±15% (293.5 lb.-ft.)	SK-RS32RN50   SK-RS32RV50	

**General Description**

Series VS\*06 pressure relief valve is a direct operated spool valve for subplate mounting with internal drain to port T. The connection and function is according to ISO 6264.

**Specifiactions**

<b>Size</b>	NG6
<b>Mounting Interface</b>	ISO 6264
<b>Mounting Position</b>	Unrestricted
<b>Ambient Temperature Range</b>	-20°C to +70°C (-4°F to +158°F)
<b>Working Pressure</b>	Port P: 350 Bar (5075 PSI) Port T: depressurized
<b>Pressure Range</b>	25 Bar (363 PSI) 64 Bar (928 PSI) 160 Bar (2320 PSI) 210 Bar (3045 PSI) 350 Bar (5075 PSI)
<b>Nominal Flow</b>	25 LPM (6.6 GPM)
<b>Pressure Fluid</b>	Hydraulic oil as per DIN 51524 ... 525
<b>Fluid Temperature Recommended Permitted</b>	+30°C to +50°C (+86°F to +122°F) -20°C to +70°C (-4°F to +158°F)
<b>Viscosity Recommended Permitted</b>	30 to 50 cSt (mm <sup>2</sup> /s) 20 to 380 cSt (mm <sup>2</sup> /s )
<b>Filtration</b>	ISO 4406 (1999), 18/16/13

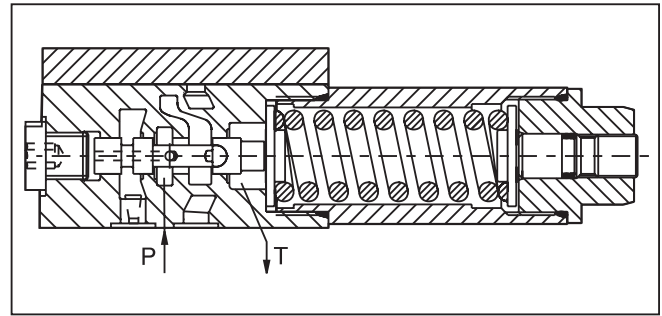
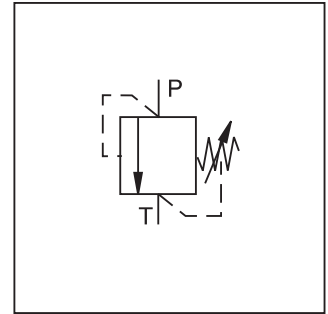

**Features**

- Spool type valve.
- Manifold mounting.
- 5 pressure ranges.
- 2 adjustment modes.

**Ordering Information**

<div style="border: 1px solid black; padding: 2px; width: 30px; margin: 0 auto;">VS</div> <p>Pressure Relief Valve</p>	<div style="border: 1px solid black; width: 30px; height: 30px; margin: 0 auto;"></div> <p>Pressure Range</p>	<div style="border: 1px solid black; padding: 2px; width: 30px; margin: 0 auto;">A</div> <p>Adjustment Screw with Hexagon Socket</p>	<div style="border: 1px solid black; padding: 2px; width: 30px; margin: 0 auto;">06</div> <p>Valve Size</p>	<div style="border: 1px solid black; padding: 2px; width: 30px; margin: 0 auto;">V</div> <p>Seal</p>	<div style="border: 1px solid black; width: 30px; height: 30px; margin: 0 auto;"></div> <p>Gage Port</p>	<div style="border: 1px solid black; width: 30px; height: 30px; margin: 0 auto;"></div> <p>Lock</p>																																	
	<table border="0"> <thead> <tr> <th>Code</th> <th>Description</th> </tr> </thead> <tbody> <tr><td>025</td><td>25 Bar (363 PSI)</td></tr> <tr><td>064</td><td>64 Bar (928 PSI)</td></tr> <tr><td>160</td><td>160 Bar (2320 PSI)</td></tr> <tr><td>210</td><td>210 Bar (3045 PSI)</td></tr> <tr><td>350</td><td>350 Bar (5075 PSI)</td></tr> </tbody> </table>	Code	Description	025	25 Bar (363 PSI)	064	64 Bar (928 PSI)	160	160 Bar (2320 PSI)	210	210 Bar (3045 PSI)	350	350 Bar (5075 PSI)	<table border="0"> <thead> <tr> <th>Code</th> <th>Description</th> </tr> </thead> <tbody> <tr><td>06</td><td>NG6</td></tr> </tbody> </table>	Code	Description	06	NG6	<table border="0"> <thead> <tr> <th>Code</th> <th>Description</th> </tr> </thead> <tbody> <tr><td>V</td><td>Fluorocarbon</td></tr> </tbody> </table>	Code	Description	V	Fluorocarbon	<table border="0"> <thead> <tr> <th>Code</th> <th>Description</th> </tr> </thead> <tbody> <tr><td>G</td><td>G 1/4"</td></tr> <tr><td>M</td><td>M 12x1.5</td></tr> <tr><td>C</td><td>Coupling M16</td></tr> </tbody> </table>	Code	Description	G	G 1/4"	M	M 12x1.5	C	Coupling M16	<table border="0"> <thead> <tr> <th>Code</th> <th>Description</th> </tr> </thead> <tbody> <tr><td>Omit</td><td>Normal</td></tr> <tr><td>Z</td><td>Cylinder Lock</td></tr> </tbody> </table>	Code	Description	Omit	Normal	Z	Cylinder Lock
Code	Description																																						
025	25 Bar (363 PSI)																																						
064	64 Bar (928 PSI)																																						
160	160 Bar (2320 PSI)																																						
210	210 Bar (3045 PSI)																																						
350	350 Bar (5075 PSI)																																						
Code	Description																																						
06	NG6																																						
Code	Description																																						
V	Fluorocarbon																																						
Code	Description																																						
G	G 1/4"																																						
M	M 12x1.5																																						
C	Coupling M16																																						
Code	Description																																						
Omit	Normal																																						
Z	Cylinder Lock																																						

**Weight:**  
1.3 kg (2.9 lbs.)

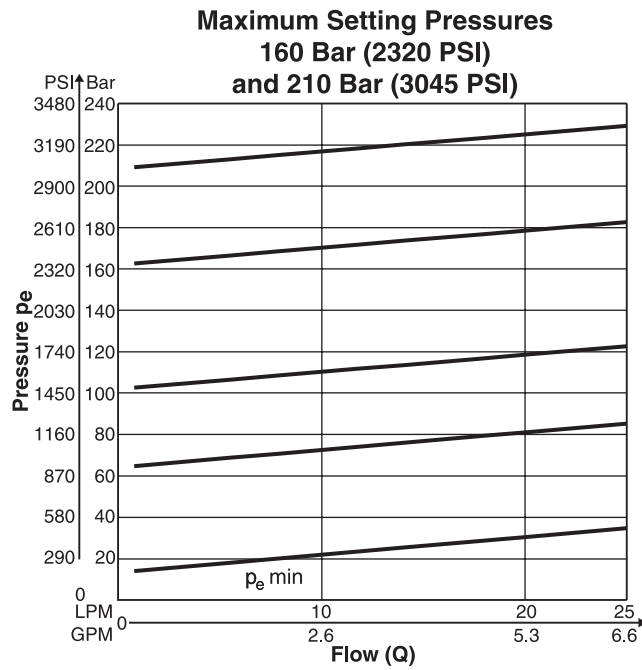
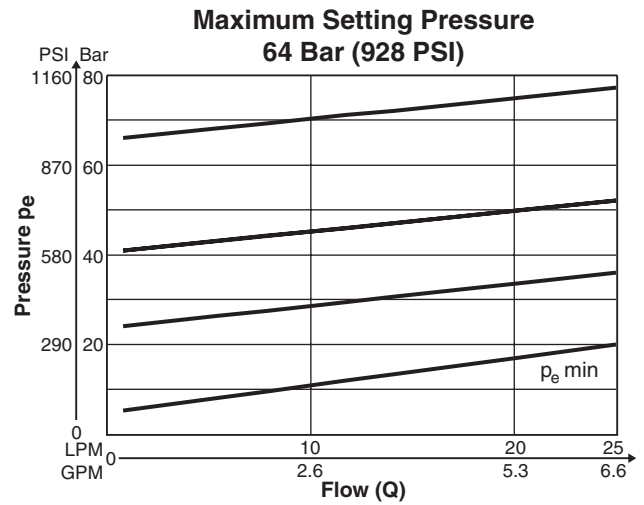
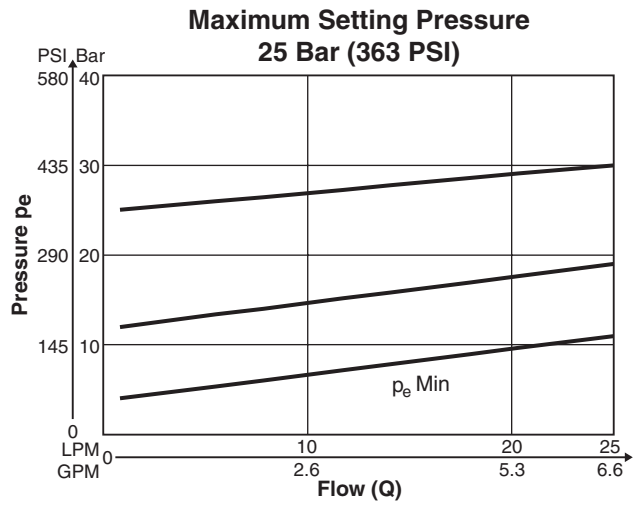

Inch equivalents for millimeter dimensions are shown in (\*\*)

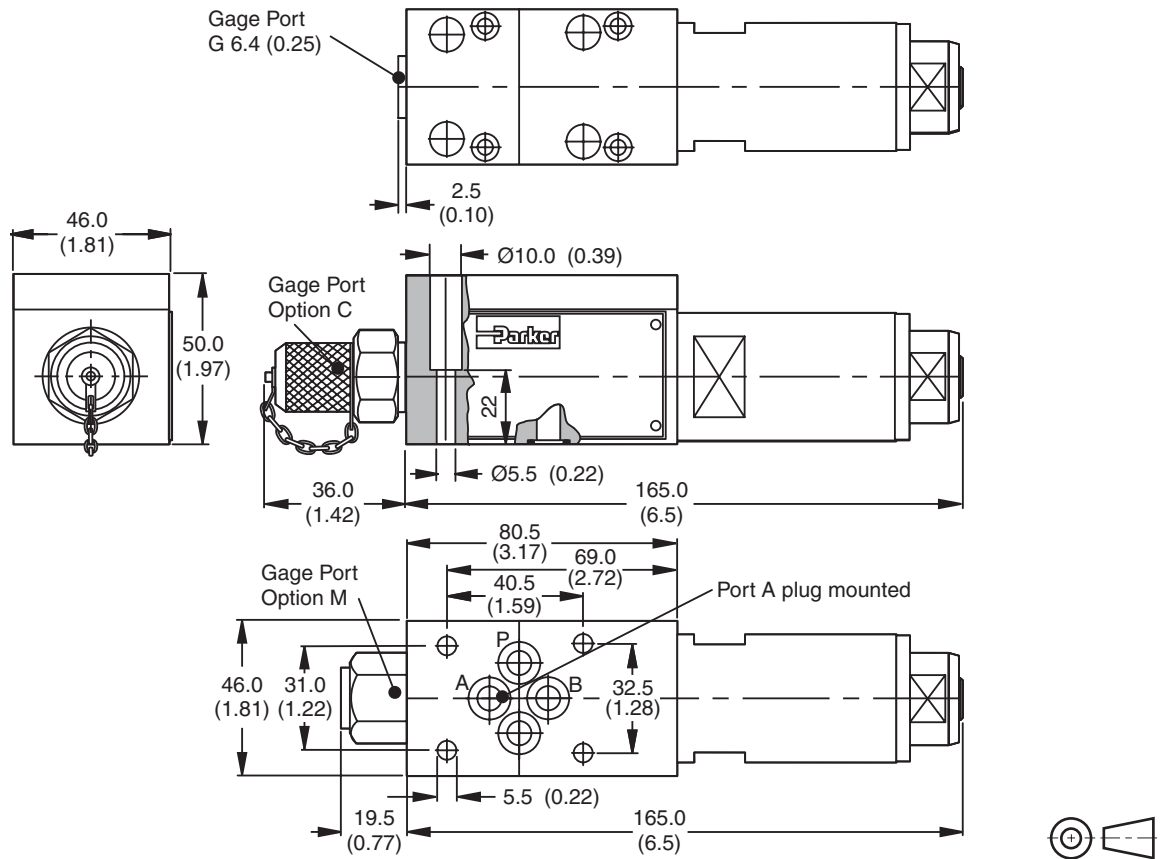

<b>Surface finish</b>	<b>Bolt kit</b>  <b>DIN912 12.9</b>		 <b>Kit FPM</b>
	SK-M5x30-4pcs	8.1Nm (6.0 lb.-ft.)	SK-VB/VM/VS-A06V

**Mounting Pattern ISO 6264-03-04-\*-97**

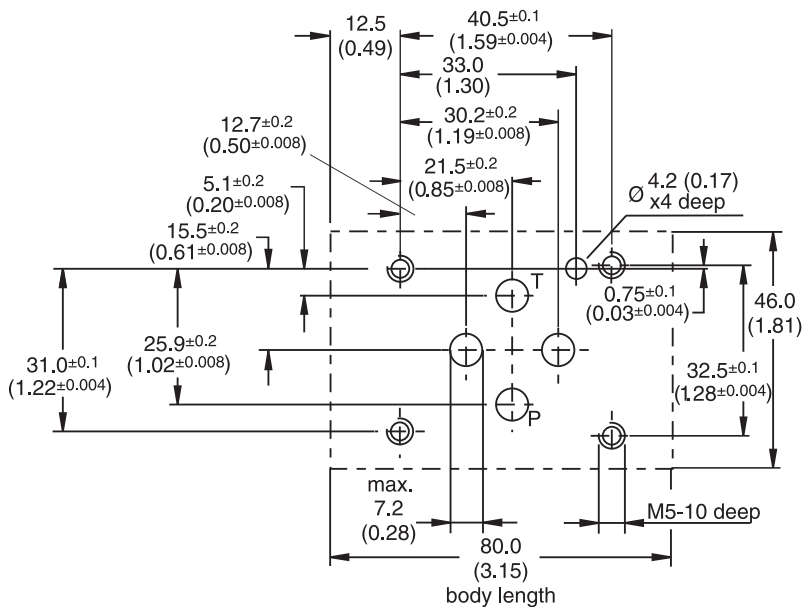

VS.indd, dd

**General Description**

Series UR\*M and US\*M are used to unload a circuit at low pressure. The mechanically adjustable pressure signal to unload the main stage has to be applied to port X. The pressure differential between opening and closing is nominal 15 or 28% of the setting pressure: 15% for pressure ranges 70 Bar (1015 PSI) and 175 Bar (2538 PSI), 28% for 250 Bar (3625 PSI) and 350 Bar (5075 PSI).

Typical applications are to unload the pumps in an accumulator circuit and to unload the low pressure stage of a double pump.

In addition, the US\*M series is vented by electrical operation.

**Features**

- Pilot operated unloading valve.
- 2 interfaces
  - Subplate interfaces to ISO 5781
  - Slip-in mounting according to ISO 7368
- 4 pressure ranges.
- 2 switching types (series US\*M).
- 3 adjustment modes
  - Hand knob
  - Screw with locknut
  - DIN lock

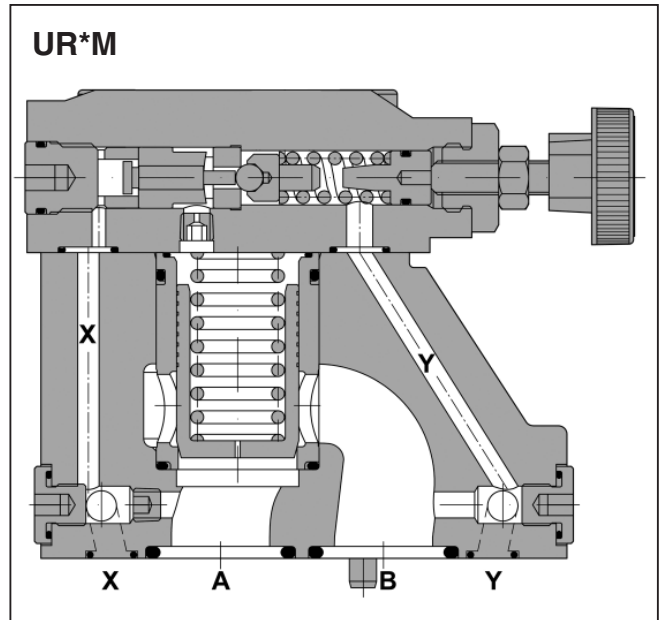
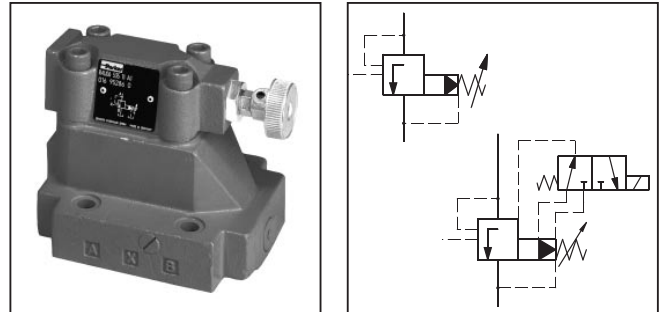

**Performance Curves**

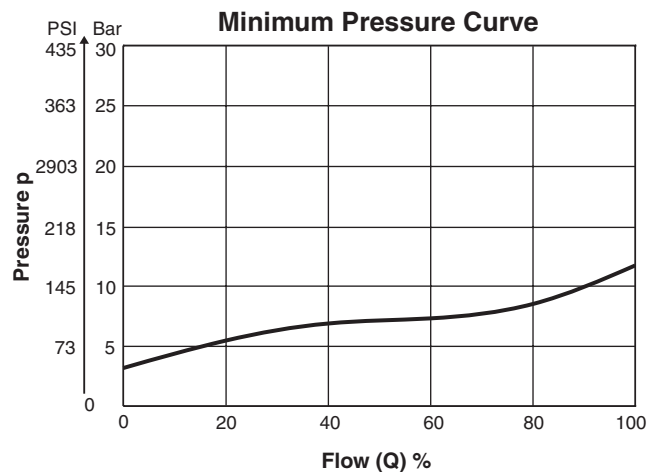
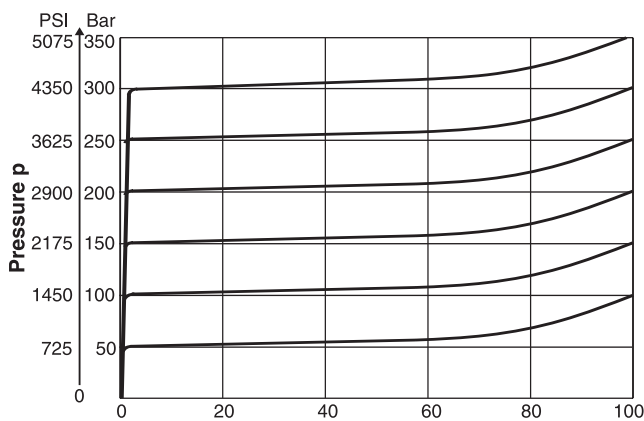

The performance curves are measured with external drain. For internal drain the tank pressure has to be added to curve.



**UR\*M**

General		NG10	NG25	NG32
<b>Size</b>				
<b>Interface</b>	Subplate mounting acc. ISO 5781			
<b>Mounting Position</b>	As desired, horizontal mounting preferred			
<b>Ambient Temperature</b>	-20°C to +80°C (-4°F to +176°F)			
Hydraulic				
<b>Operating Pressure</b>	Ports A and X up to 350 Bar (5075 PSI), connection B and Y depressurized			
<b>Pressure Range</b>	75, 175, 250, 350 Bar (1088, 2538, 3625, 5075 PSI)			
<b>Pressure Differential</b>	15% for pressure ranges 75 Bar (1088 PSI) and 175 Bar (2538 PSI) 28% for pressure ranges 250 Bar (3625 PSI and 350 Bar (5075 PSI)			
<b>Nominal Flow</b>	150 LPM (39.7 GPM)	350 LPM (92.6 GPM)	650 LPM (172.0 GPM)	
<b>Pressure Fluid</b>	Hydraulic oil according to DIN 51524 ... 525			
<b>Viscosity Recommended Maximum</b>	30 to 50 cSt (mm <sup>2</sup> /s) 20 to 380 cSt (mm <sup>2</sup> /s)			
<b>Pressure Fluid Temperature Recommended Maximum</b>	+30°C to +50°C (+86°F to +122°F) -20°C to +70°C (-4°F to +158°F)			
<b>Filtration</b>	ISO 4406 (1999), 18/16/13			

**US\*M with Vent Function**

General		NG10	NG25	NG32
<b>Size</b>				
<b>Interface</b>	Subplate mounting acc. ISO 5781			
<b>Mounting Position</b>	As desired, horizontal mounting preferred			
<b>Ambient Temperature</b>	-20°C to +80°C (-4°F to +176°F)			
Hydraulic				
<b>Operating Pressure</b>	Ports A and X up to 350 Bar (5075 PSI), connection B and Y depressurized			
<b>Pressure Range</b>	75, 175, 250, 350 Bar (1088, 2538, 3625, 5075 PSI)			
<b>Pressure Differential</b>	15% for pressure ranges 75 Bar (1088 PSI) and 175 Bar (2538 PSI) 28% for pressure ranges 250 Bar (3625 PSI and 350 Bar (5075 PSI)			
<b>Nominal Flow</b>	150 LPM (39.7 GPM)	350 LPM (92.6 GPM)	650 LPM (172.0 GPM)	
<b>Pressure Fluid</b>	Hydraulic oil according to DIN 51524 ... 525			
<b>Viscosity Recommended Maximum</b>	30 to 50 cSt (mm <sup>2</sup> /s) 20 to 380 cSt (mm <sup>2</sup> /s)			
<b>Pressure Fluid Temperature Recommended Maximum</b>	+30°C to +50°C (+86°F to +122°F) -20°C to +70°C (-4°F to +158°F)			
<b>Filtration</b>	ISO 4406 (1999), 18/16/13			
Electrical (solenoid)				
<b>Duty Cycle</b>	100% ED			
<b>Plug Connectors</b>	2 pole + PE / connector acc. to EN 175301-803			
<b>Protection Class</b>	IP54 at DIN 40050 (plugged and mounted)			
<b>Supply Voltage</b>	<b>Volt</b>	<b>Code</b>	<b>Power (W)</b>	<b>Current (A)</b>
	12	K		2.5
	24	J	31	1.25
	98	U		0.31
	198	G		0.15
<b>Response Time</b>	Energized / de-energized 32/40 ms			
<b>Switching Frequency</b>	Max. 15,000 switchings/hour			

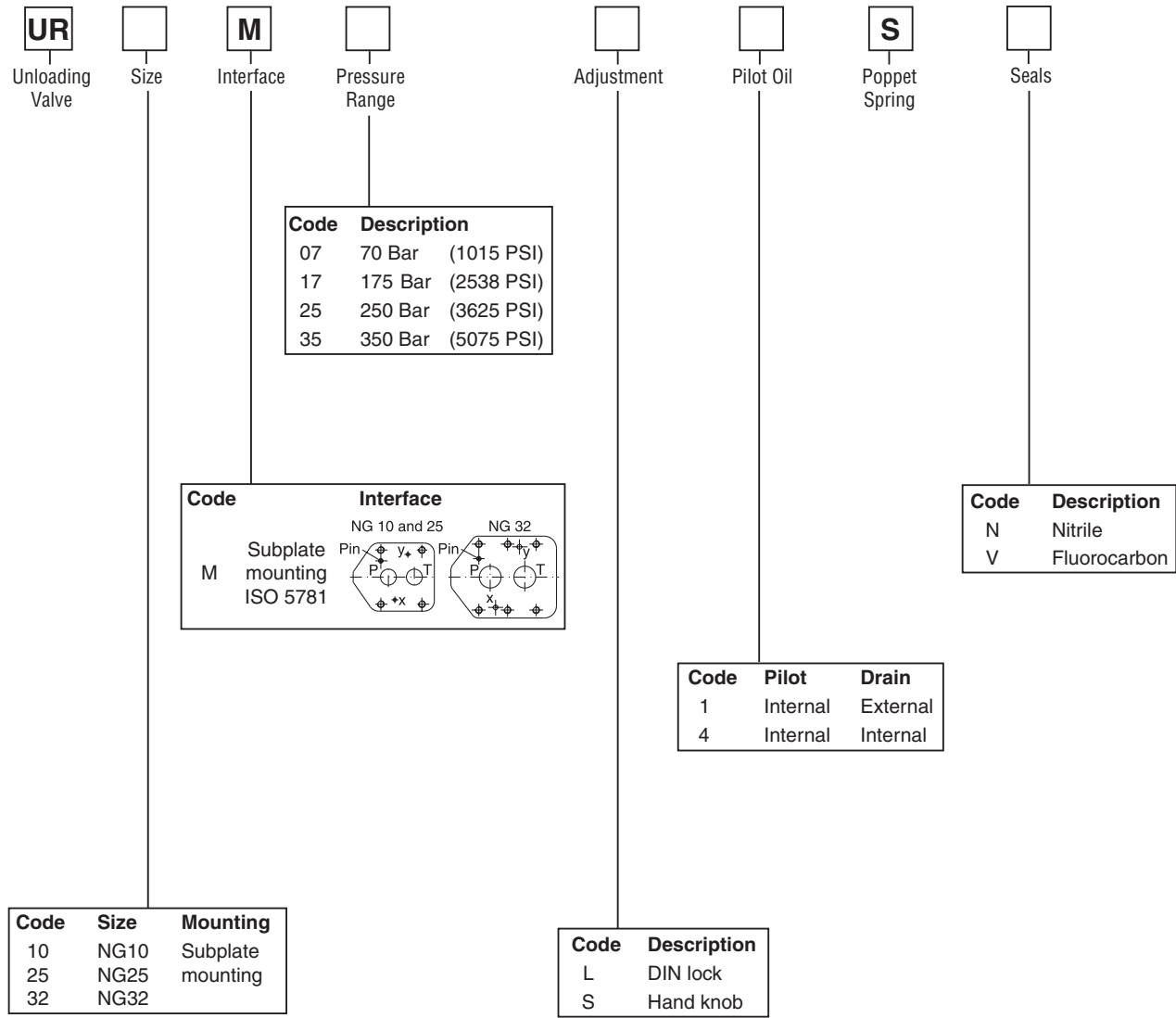

**Weight:**  
 UR10M 2.7 kg (6.0 lbs.)  
 UR25M 4.5 kg (9.9 lbs.)  
 UR32M 6.0 kg (13.2 lbs.)

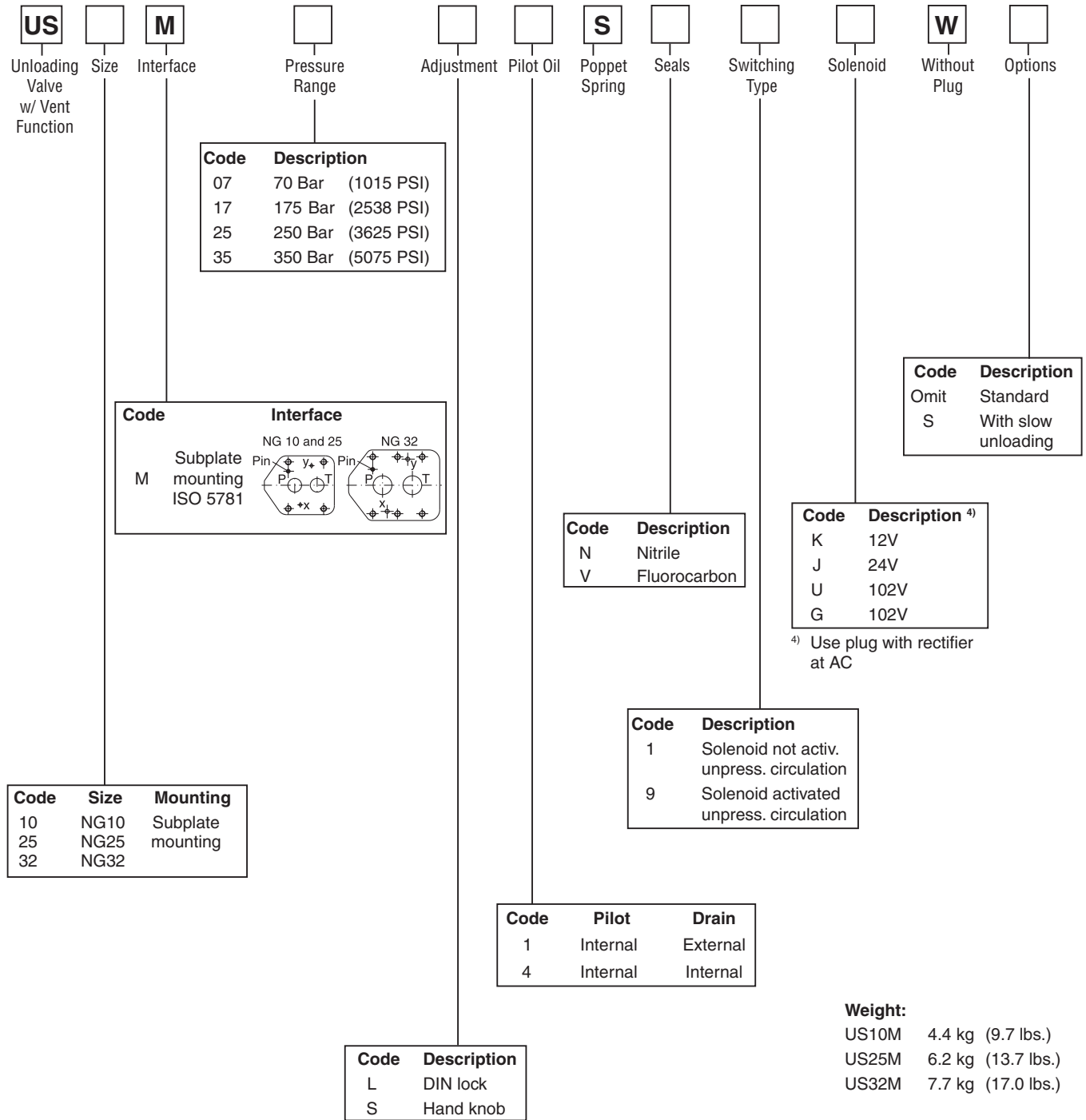

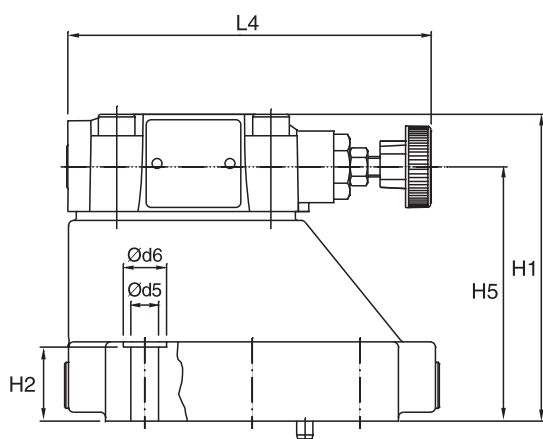
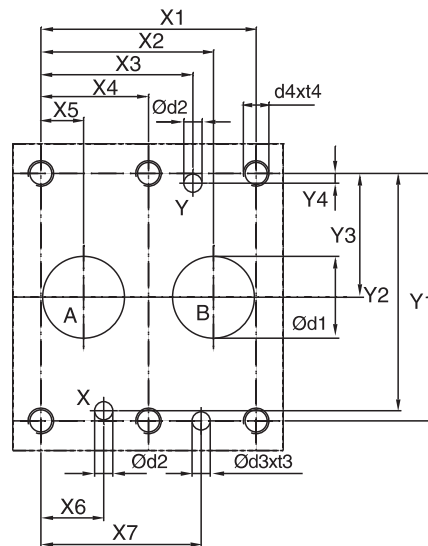
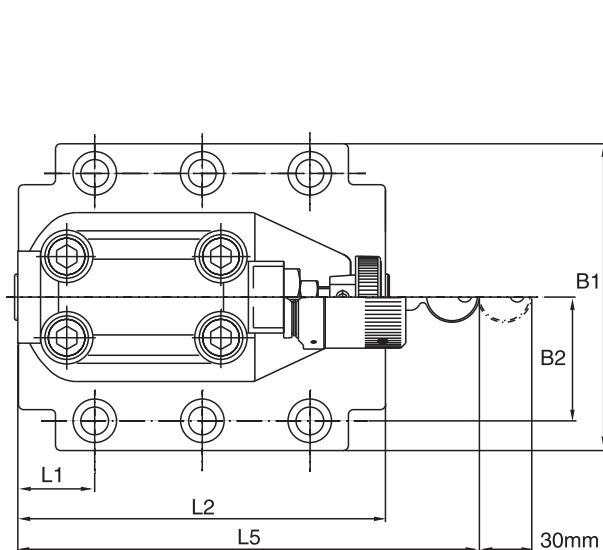

**Dimensions**

**Pressure Unloading Valve  
Series UR\*M**



Inch equivalents for millimeter dimensions are shown in (\*\*)

NG	ISO-code	x1	x2	x3	x4	x5	x6	x7	y1	y2	y3	y4	y5	y6
10	5781-06-07-0-00	42.9 (1.69)	35.8 (1.41)	21.5 (0.85)	—	7.2 (0.28)	21.5 (0.85)	31.8 (1.25)	66.7 (2.63)	58.8 (2.31)	33.4 (1.31)	7.9 (0.31)	—	—
25	5781-08-10-0-00	60.3 (2.37)	49.2 (1.94)	39.7 (1.56)	—	11.1 (0.44)	20.6 (0.81)	44.5 (1.75)	79.4 (3.13)	73.0 (2.87)	39.7 (1.56)	6.4 (0.25)	—	—
32	5781-10-13-0-00	84.2 (3.31)	67.5 (2.66)	59.5 (2.34)	42.1 (1.66)	16.7 (0.66)	24.6 (0.97)	62.7 (2.47)	96.8 (3.81)	92.8 (3.65)	48.4 (1.91)	3.8 (0.15)	—	—

Tolerance at X and Y pin holes and screw holes ±0.1, at port holes ±0.2.

NG	ISO-code	B1	B2	H1	H2	H3	H4	H5	H6	L1	L2	L3	L4	L5	L6
10	5781-06-07-0-00	87.3 (3.44)	33.4 (1.31)	83.0 (3.27)	21.0 (0.83)	62.5 (2.46)	—	—	—	29.0 (1.14)	94.8 (3.73)	—	141.0 (5.55)	181.0 (7.13)	—
25	5781-08-10-0-00	105.0 (4.13)	39.7 (1.56)	109.5 (4.31)	29.0 (1.14)	89.0 (3.50)	—	—	—	34.7 (1.37)	126.8 (4.99)	—	141.0 (5.55)	181.0 (7.13)	—
32	5781-10-13-0-00	120.0 (4.72)	48.4 (1.91)	120.0 (4.72)	29.0 (1.14)	99.5 (3.92)	—	—	—	30.6 (1.20)	144.3 (5.68)	—	141.0 (5.55)	181.0 (7.13)	—

NG	ISO-code	d1max	d2max	d3	t3	d4	t4	d5	d6
10	5781-06-07-0-00	15.0 (0.59)	7.0 (0.28)	7.1 (0.28)	8.0 (0.31)	M10	16.0 (0.63)	10.8 (0.43)	17.0 (0.67)
25	5781-08-10-0-00	23.4 (0.92)	7.1 (0.28)	7.1 (0.28)	8.0 (0.31)	M10	18.0 (0.71)	10.8 (0.43)	17.0 (0.67)
32	5781-10-13-0-00	32.0 (1.26)	7.1 (0.28)	7.1 (0.28)	8.0 (0.31)	M10	20.0 (0.79)	10.8 (0.43)	17.0 (0.67)

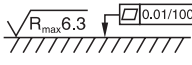
NG	ISO-code	Bolt kit  DIN912 12.9		NBR  Kit	FPM	Surface finish
10	5781-06-07-0-00	BK-M10 x 35-4pcs	63 Nm (46.5 lb.-ft.)	SK-UR10MN50	SK-UR10MV50	
25	5781-08-10-0-00	BK-M10 x 45-4pcs	63 Nm (46.5 lb.-ft.)	SK-UR25MN50	SK-UR25MV50	
32	5781-10-13-0-00	BK-M10 x 45-6pcs	63 Nm (46.5 lb.-ft.)	SK-UR32MN50	SK-UR32MV50	

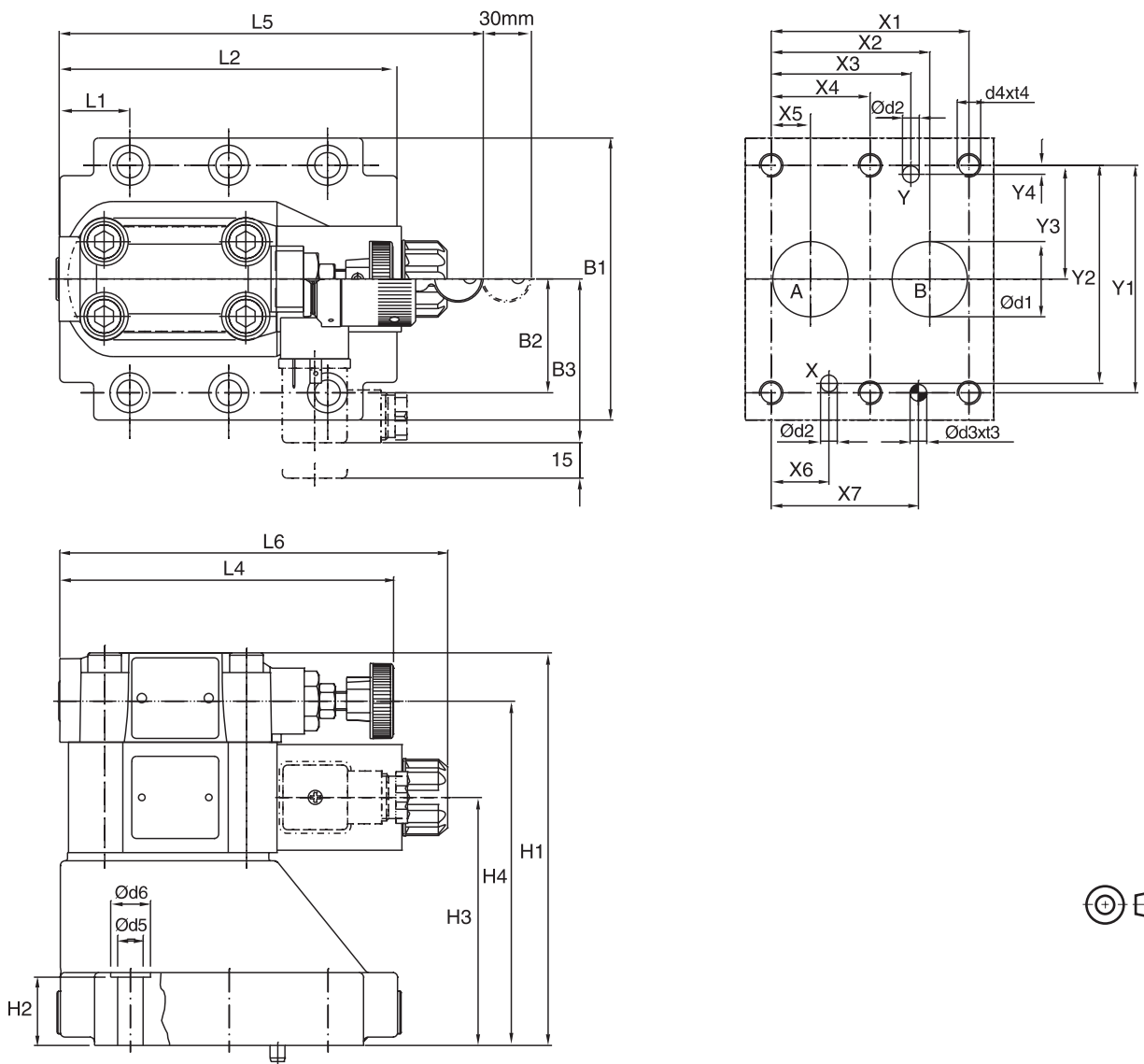

**Dimensions**

**Pressure Unloading Valve  
Series US\*M**



Inch equivalents for millimeter dimensions are shown in (\*\*)

NG	ISO-code	x1	x2	x3	x4	x5	x6	x7	y1	y2	y3	y4	y5	y6
10	5781-06-07-0-00	42.9 (1.69)	35.8 (1.41)	21.5 (0.85)	–	7.2 (0.28)	21.5 (0.85)	31.8 (1.25)	66.7 (2.63)	58.8 (2.31)	33.4 (1.31)	7.9 (0.31)	–	–
25	5781-08-10-0-00	60.3 (2.37)	49.2 (1.94)	39.7 (1.56)	–	11.1 (0.44)	20.6 (0.81)	44.5 (1.75)	79.4 (3.13)	73.0 (2.87)	39.7 (1.56)	6.4 (0.25)	–	–
32	5781-10-13-0-00	84.2 (3.31)	67.5 (2.66)	59.5 (2.34)	42.1 (1.66)	16.7 (0.66)	24.6 (0.97)	62.7 (2.47)	96.8 (3.81)	92.8 (3.65)	48.4 (1.91)	3.8 (0.15)	–	–

Tolerance at X and Y pin holes and screw holes ±0.1, at port holes ±0.2.

NG	ISO-code	B1	B2	B3	H1	H2	H3	H4	H5	H6	L1	L2	L3	L4	L5	L6
10	5781-06-07-0-00	87.3 (3.44)	33.4 (1.31)	70.0 (2.76)	130.0 (5.12)	21.0 (0.83)	68.5 (2.70)	109.5 (4.13)	–	–	29.0 (1.14)	94.8 (3.73)	–	141.0 (5.55)	181.0 (7.13)	165.6 (6.52)
25	5781-08-10-0-00	105.0 (4.13)	39.7 (1.56)	70.0 (2.76)	156.5 (6.16)	29.0 (1.14)	95.0 (3.74)	136.0 (5.35)	–	–	34.7 (1.37)	126.8 (4.99)	–	141.0 (5.55)	181.0 (7.13)	165.6 (6.52)
32	5781-10-13-0-00	120.0 (4.72)	48.4 (1.91)	70.0 (2.76)	167.0 (6.57)	29.0 (1.14)	105.5 (4.15)	146.5 (5.77)	–	–	30.6 (1.20)	144.3 (5.68)	–	141.0 (5.55)	181.0 (7.13)	165.6 (6.52)

NG	ISO-code	d1max	d2max	d3	t3	d4	t4	d5	d6
10	5781-06-07-0-00	15.0 (0.59)	7.0 (0.28)	7.1 (0.28)	8.0 (0.31)	M10	16.0 (0.63)	10.8 (0.43)	17.0 (0.67)
25	5781-08-10-0-00	23.4 (0.92)	7.1 (0.28)	7.1 (0.28)	8.0 (0.31)	M10	18.0 (0.71)	10.8 (0.43)	17.0 (0.67)
32	5781-10-13-0-00	32.0 (1.26)	7.1 (0.28)	7.1 (0.28)	8.0 (0.31)	M10	20.0 (0.79)	10.8 (0.43)	17.0 (0.67)

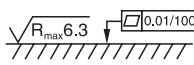
NG	ISO-code	Bolt kit  DIN912 12.9		NBR  Kit FPM	Surface finish 
10	5781-06-07-0-00	BK-M10 x 35-4pcs	63 Nm (46.5 lb.-ft.)	SK-RS10RN50   SK-RS10RV50	
25	5781-08-10-0-00	BK-M10 x 45-4pcs	63 Nm (46.5 lb.-ft.)	SK-RS25RN50   SK-RS25RV50	
32	5781-10-13-0-00	BK-M10 x 45-6pcs	63 Nm (46.5 lb.-ft.)	SK-RS32RN50   SK-RS32RV50	

**General Description**

Series UR6M unloading relief valves act to limit maximum system pressure and to unload the pump at maximum pressure allowing the accumulator to maintain system pressure until pressure drops to 85 percent of maximum.

Under minimum pressure setting conditions (see Specifications), Series UR unloading relief valves function as indicated (see Performance Curves, below).

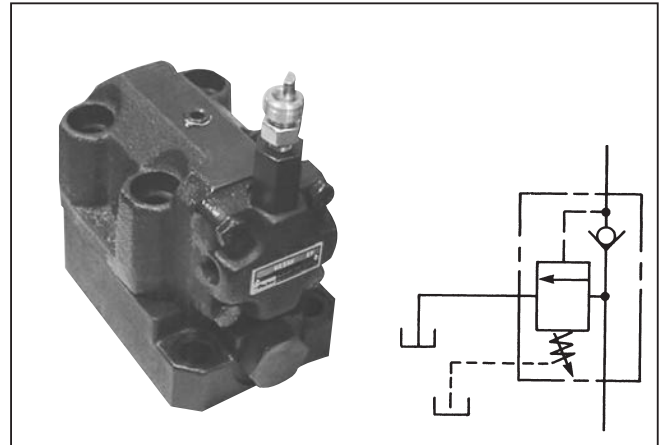

**Specifications**

<b>Pressure Adjustment Range*</b>	Code H: 55 - 205 Bar (1300 - 3000 PSI) Load/Unload PSI - 85%  Code M: 10.2 - 34 Bar (150 - 500 PSI) Load/Unload PSI - 70%
<b>Maximum Operating Pressure</b>	205 Bar (3000 PSI)
<b>Cracking Pressure</b>	0.2 Bar (3 PSI) Accumulator Check Valve
<b>Minimum Pressure Setting</b>	113.6 LPM (30 GPM) minimum 32 cSt (150 SSU) oil and fluid temperature of 38°C (100°F)  Note: Change in flow, temperature or fluid [cSt. (SSU)] rating will affect valve minimum pressure.
<b>Flow Rate</b>	7.6 LPM (2 GPM) Minimum
<b>Drain Conditions</b>	0.7 Bar (10 PSI) Maximum Pressure 1 LPM (0.3 GPM) Typical Flow
<b>Drain Line</b>	Must be run directly back to tank terminating below the oil level.

\* See Ordering Information

**Performance Curves**

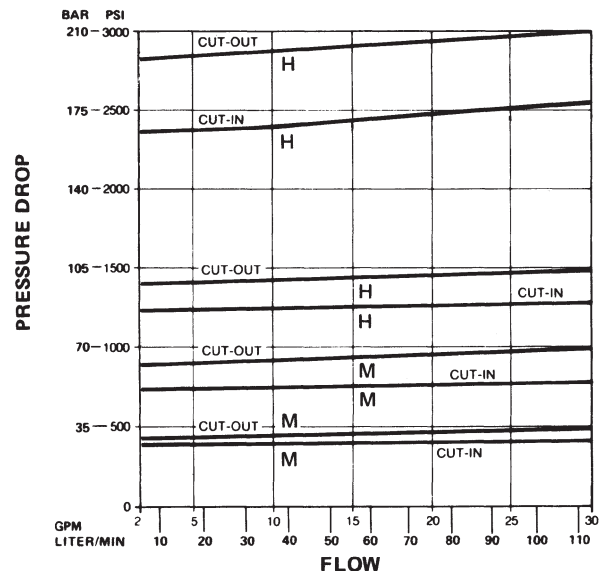

**Cut-in / Cut-out Curves**

**Flow Data**

Valve Model	Maximum Flow GPM (L/M)	Mounting Style	Port Size
UR6M	30 GPM (114 L/M)	Subplate	3/4 NPTF*

\*Refers to subplate port size.

**Ordering Information**

<div style="border: 1px solid black; padding: 2px; width: 30px; margin: 0 auto;">UR</div> <p>Unloading Relief Valve</p>	<div style="border: 1px solid black; padding: 2px; width: 30px; margin: 0 auto;">6M</div> <p>Nominal Size</p>	<div style="border: 1px solid black; padding: 2px; width: 30px; margin: 0 auto;"></div> <p>Cut-out Pressure Range</p>	<div style="border: 1px solid black; padding: 2px; width: 30px; margin: 0 auto;"></div> <p>Seals</p>	<div style="border: 1px solid black; padding: 2px; width: 30px; margin: 0 auto;"></div> <p>Design Series</p>																
<table border="0"> <tr> <th style="text-align: left;">Code</th> <th style="text-align: left;">Description</th> </tr> <tr> <td>6M</td> <td>3/4" Subplate</td> </tr> </table>	Code	Description	6M	3/4" Subplate	<table border="0"> <tr> <th style="text-align: left;">Code</th> <th style="text-align: left;">Description</th> </tr> <tr> <td>H</td> <td>89.7 to 207 Bar (1300 to 3000 PSI)</td> </tr> <tr> <td>M</td> <td>27.6 to 100.1 Bar (400 to 1500 PSI)</td> </tr> </table>	Code	Description	H	89.7 to 207 Bar (1300 to 3000 PSI)	M	27.6 to 100.1 Bar (400 to 1500 PSI)	<table border="0"> <tr> <th style="text-align: left;">Code</th> <th style="text-align: left;">Description</th> </tr> <tr> <td>Omit</td> <td>Nitrile</td> </tr> <tr> <td>V</td> <td>Fluorocarbon</td> </tr> </table>	Code	Description	Omit	Nitrile	V	Fluorocarbon	<p>This section covers Design Series 10 thru 19.</p> <p>Note: Not required when ordering.</p>	
Code	Description																			
6M	3/4" Subplate																			
Code	Description																			
H	89.7 to 207 Bar (1300 to 3000 PSI)																			
M	27.6 to 100.1 Bar (400 to 1500 PSI)																			
Code	Description																			
Omit	Nitrile																			
V	Fluorocarbon																			

**Weight:**  
 UR6M 11.3 kg (25 lbs.)



**Dimensions**

**Unloading Relief Valve  
Series UR6M**

Millimeter equivalents for inch dimensions are shown in (\*\*)

**Manifold mounted Unloading Valve**

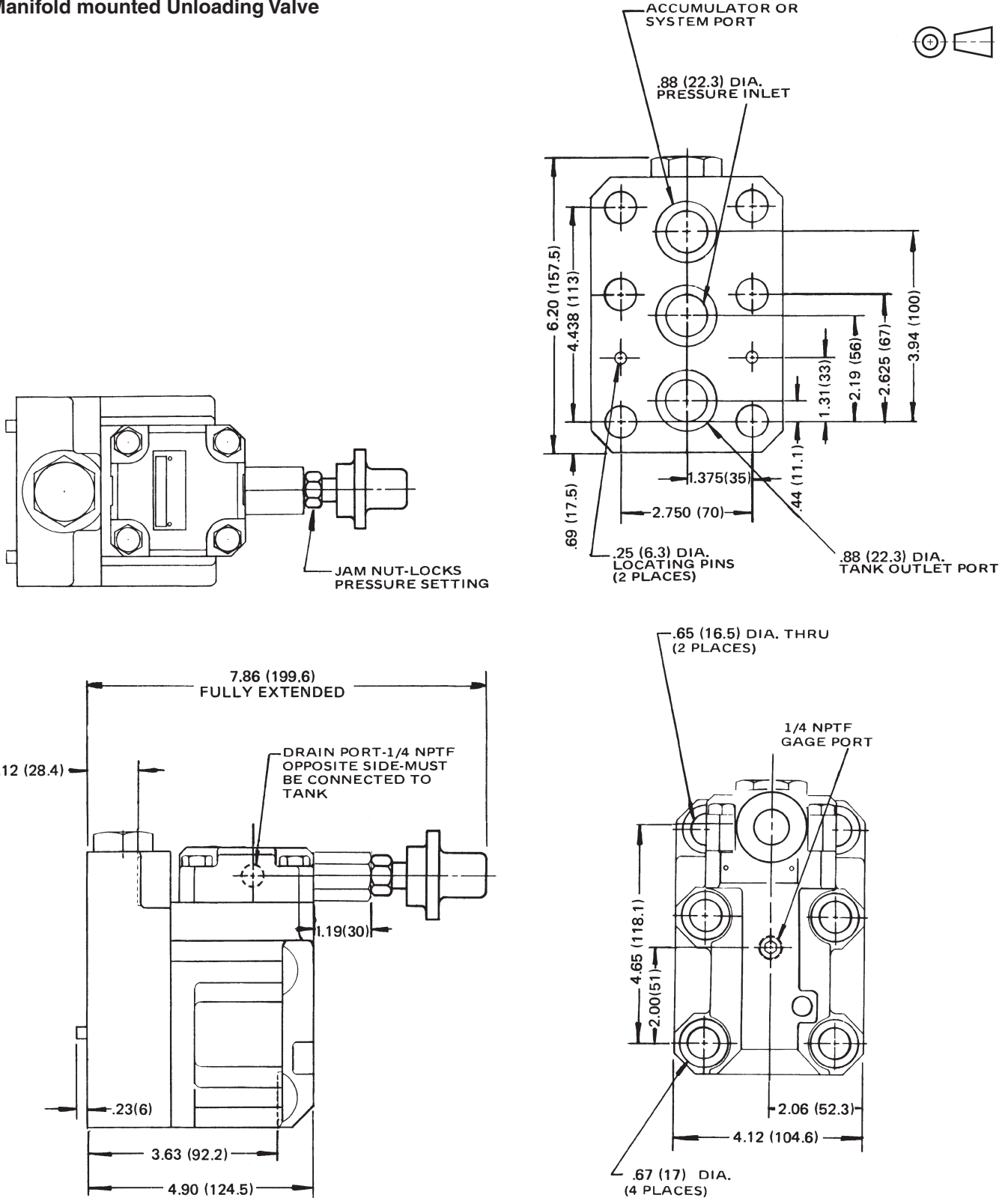

### General Description

Series PR\*S pressure reducing valves maintain an independently controlled constant outlet pressure on one leg of the hydraulic system, regardless of pressure at the valve inlet or on the main relief valve. Inlet pressure on a Series PR valve must be higher than the pressure setting on the valve.

Made from alloy steel bar stock, Series PR valves are compact and require minimum space. They can be installed in any position. They are used on installations that do not require service of equal reliability.

The one-hand adjusting knob is self-locking at desired pressure. Pull the knob and turn to adjust; release knob to lock positively.

Drain lines of Series PR valves should be connected directly to tank below fluid level. Pressure in any drain line is in addition to the valve pressure chosen.

For certain unusual installations, the drain line can be pressurized or restricted to improve valve pressure reducing performance. For example, if full pressure is applied to the drain, the Series PR valve will open, preventing pressure reduction. Pressurizing or restricting the drain will avoid this. However, be careful in using Series PR valves in other than normal applications; consult your Parker representative or the Factory.

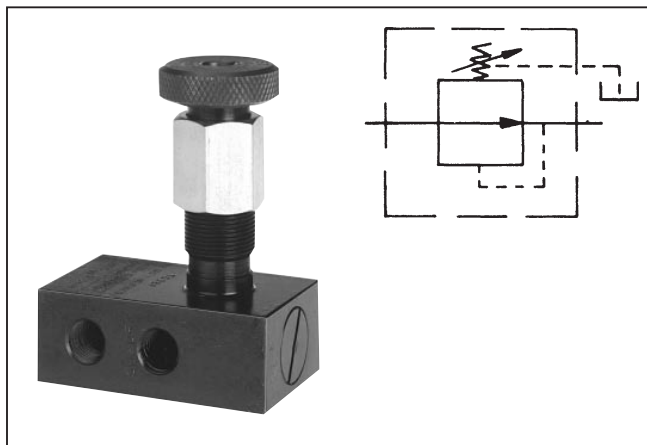

### Specifications

<b>Pressure Adjustment Ranges</b>	3.5 - 70 Bar (50 - 1000 PSI) 10.5 - 140 Bar (500 - 2000 PSI) 10.5 - 210 Bar (150 - 3000 PSI)
<b>Maximum Operating Pressure</b>	210 Bar (3000 PSI)
<b>Pressure Setting</b>	3.5 Bar (50 PSI) minimum, at rated flow  Note: Changes in flow, viscosity or temperature will affect valve minimum pressure.

### Flow Data

Valve Model	Port Size	Flow (Max)
PR400S	1/4 NPTF	6 GPM (25 L/M)
PR600S	3/8 NPTF	10 GPM (40 L/M)
PR800S	1/2 NPTF	15 GPM (60 L/M)

### Ordering Information

Example: "PR400SVF" means Series PR relief valve, 1/4" size, steel, 150-2000 PSI pressure range, optional Fluorocarbon seal.

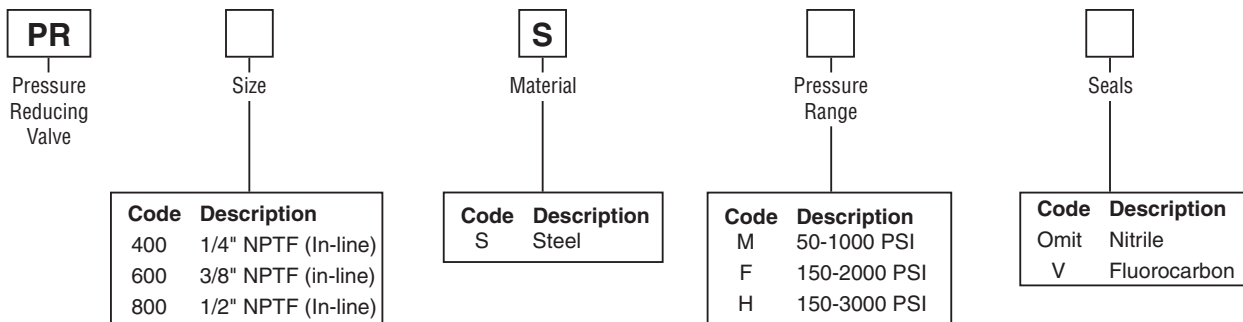

**Dimensions**

Millimeter equivalents for inch dimensions are shown in (\*\*)

In-line mounted, pilot operated  
Pressure Reducing Valves

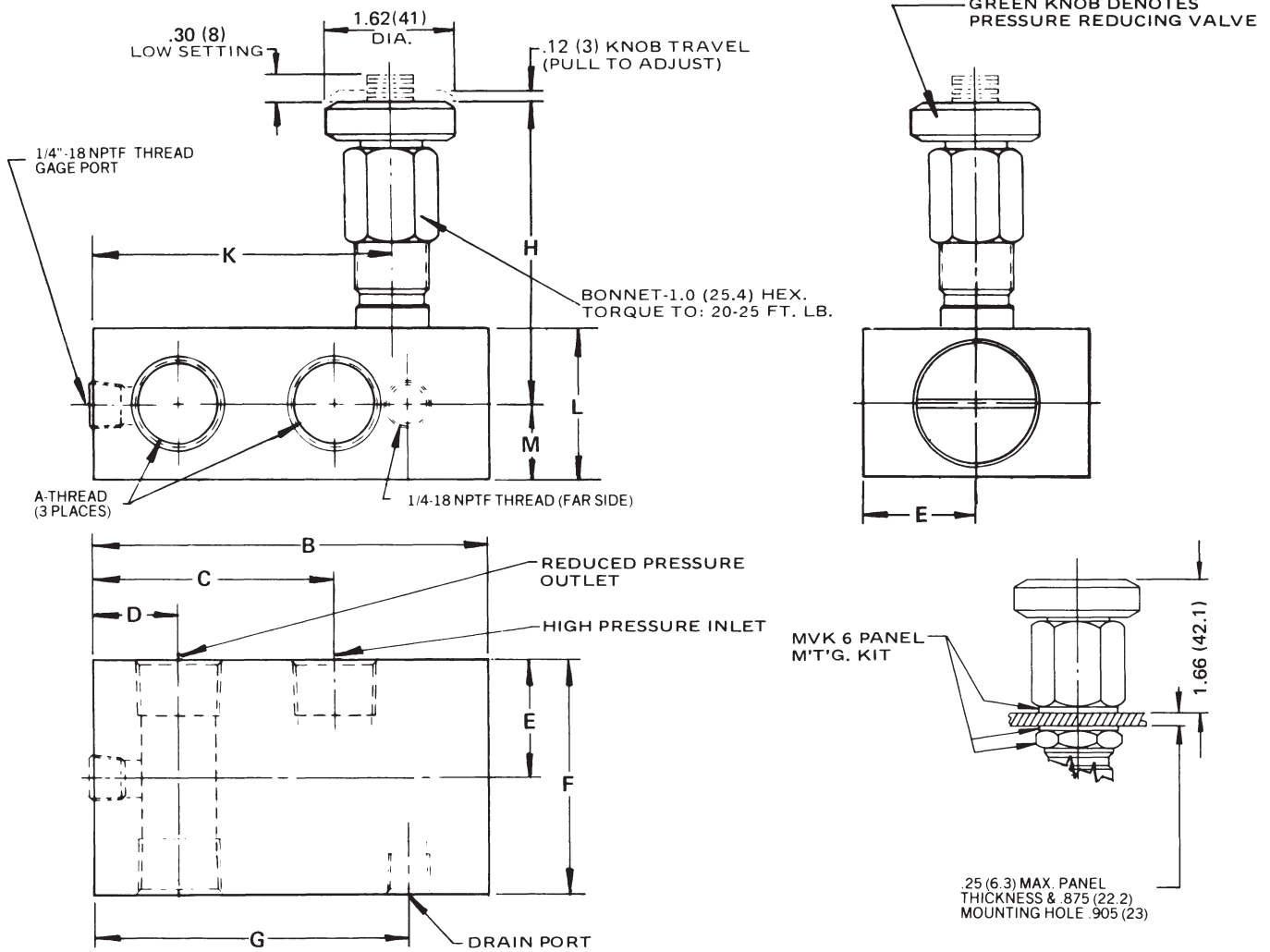

Valve Model	A-Thread	B	C	D	E	F	G	H	K	L	M	Weight Lb. (Kg.)
PR400S	1/4-18 NPTF	3.00 (76.2)	1.60 (41)	.67 (17)	.88 (22.3)	1.75 (44.4)	2.25 (57.1)	3.16 (80.2)	2.04 (52)	1.12 (28.4)	.56 (14.2)	1.9 (0.9)
PR600S	3/8-18 NPTF	3.53 (90)	2.00 (51)	.75 (19)	1.00 (25.4)	2.00 (51)	2.77 (70.3)	3.22 (82)	2.62 (66.5)	1.25 (32)	.62 (16)	2.6 (1.2)
PR800S	1/2-14 NPTF	4.10 (104.1)	2.40 (61)	.91 (23.1)	1.12 (28.4)	2.25 (57.1)	3.17 (81)	3.34 (85)	3.03 (77)	1.50 (38.1)	.75 (19)	3.7 (1.7)

### General Description

Series PR pressure reducing valves are used to control the pressure in the secondary part of the hydraulic system. Independent of the primary pressure the secondary pressure is reduced to the pressure setting. In order to avoid undesired motion the valves are normally closed.

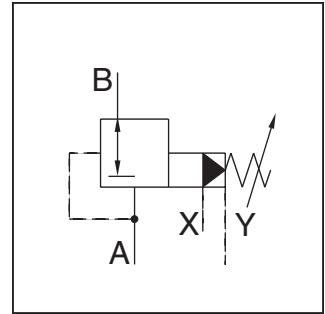

### Specifications

<b>Size</b>	NG10, NG25, NG32
<b>Interface</b>	Subplate mounting acc. ISO 5781
<b>Mounting Pos.</b>	As desired, horizontal mounting preferred
<b>Ambient Temp.</b>	-20°C to +80°C (-4°F to +176°F)
<b>Max. Oper. Pressure</b>	Ports A, B and X 350 Bar (5075 PSI), connection Y depressurized
<b>Pressure Range</b>	105, 175, 250, 350 Bar (1523, 2538, 3625, 5075 PSI)
<b>Nominal Flow</b>	<b>Size 10:</b> 150 LPM (39.7 GPM) <b>Size 25:</b> 350 LPM (92.6 GPM) <b>Size 32:</b> 650 LPM (172.0 GPM)
<b>Pressure Fluid</b>	Hydraulic oil according to DIN 51524... 525
<b>Pressure Fluid Temperature</b>	<b>Recommended:</b> +30C to +50°C (86°F to +122°F) <b>Maximum:</b> -20°C to +70°C (-4°F to +158°F)
<b>Viscosity</b>	<b>Recommended:</b> 30 to 50 mm <sup>2</sup> /s <b>Maximum:</b> 20 to 380 mm <sup>2</sup> /s
<b>Filtration</b>	ISO 4406 (1999), 18/16/13

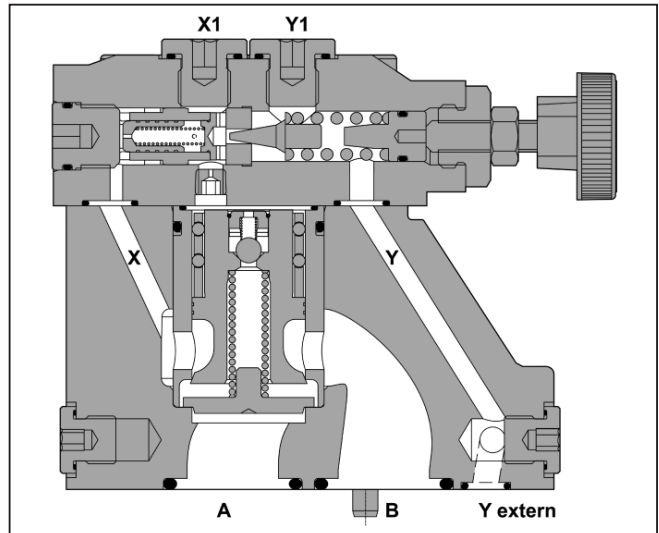

### Features

- Subplate mounting acc. to ISO 5781.
- Normally closed.
- Four pressure ranges.
- Two adjustment modes: hand knob and DIN lock.

### Ordering Information

<b>PR</b>	□	<b>M</b>	□	□	<b>1</b>	<b>P</b>	□	<b>9</b>																														
Pressure Reducing Valve	Nominal Size	Interface	Pressure Ranges	Adjustment	Pilot Oil: External Drain	Poppet Spring	Seals	Normally Closed																														
<table border="0"> <tr><th>Code</th><th>Description</th></tr> <tr><td>10</td><td>NG10</td></tr> <tr><td>25</td><td>NG25</td></tr> <tr><td>32</td><td>NG32</td></tr> </table> <p>Mounting: Subplate mounting</p>	Code	Description	10	NG10	25	NG25	32	NG32		<table border="0"> <tr><th>Code</th><th>Description</th></tr> <tr><td>10</td><td>105 Bar (1523 PSI)</td></tr> <tr><td>17</td><td>175 Bar (2538 PSI)</td></tr> <tr><td>25</td><td>250 Bar (3625 PSI)</td></tr> <tr><td>35</td><td>350 Bar (5075 PSI)</td></tr> </table>	Code	Description	10	105 Bar (1523 PSI)	17	175 Bar (2538 PSI)	25	250 Bar (3625 PSI)	35	350 Bar (5075 PSI)		<table border="0"> <tr><th>Code</th><th>Description</th></tr> <tr><td>L</td><td>DIN Lock</td></tr> <tr><td>S</td><td>Hand knob</td></tr> </table>	Code	Description	L	DIN Lock	S	Hand knob		<table border="0"> <tr><th>Code</th><th>Description</th></tr> <tr><td>N</td><td>Nitrile</td></tr> <tr><td>V</td><td>Fluorocarbon</td></tr> </table>	Code	Description	N	Nitrile	V	Fluorocarbon		
Code	Description																																					
10	NG10																																					
25	NG25																																					
32	NG32																																					
Code	Description																																					
10	105 Bar (1523 PSI)																																					
17	175 Bar (2538 PSI)																																					
25	250 Bar (3625 PSI)																																					
35	350 Bar (5075 PSI)																																					
Code	Description																																					
L	DIN Lock																																					
S	Hand knob																																					
Code	Description																																					
N	Nitrile																																					
V	Fluorocarbon																																					
<table border="0"> <tr><th>Code</th><th>Interface</th></tr> <tr><td>M</td><td>Subplate Mounting ISO 5781</td></tr> </table>	Code	Interface	M	Subplate Mounting ISO 5781																																		
Code	Interface																																					
M	Subplate Mounting ISO 5781																																					

**Weight:**

NG10:	4.8 kg (10.6 lbs.)
NG25:	7.2 kg (15.9 lbs.)
NG32:	13.5 kg (29.8 lbs.)

**PR10M\*W 1)**

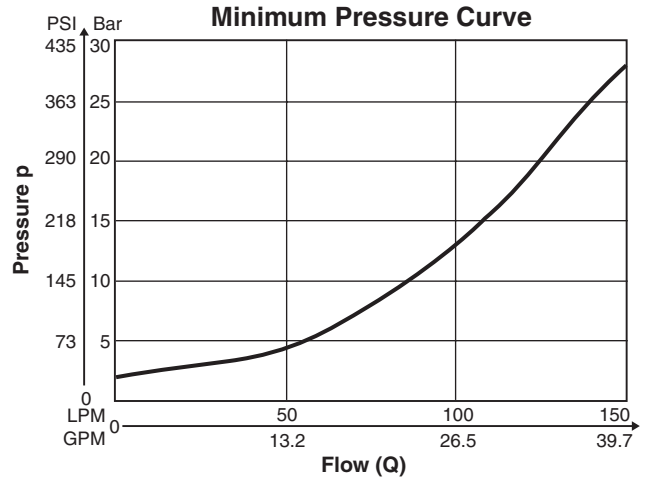
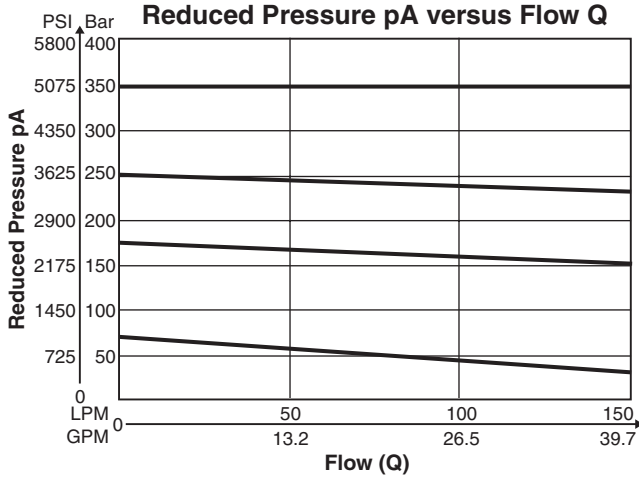

**PR25M\*W 1)**

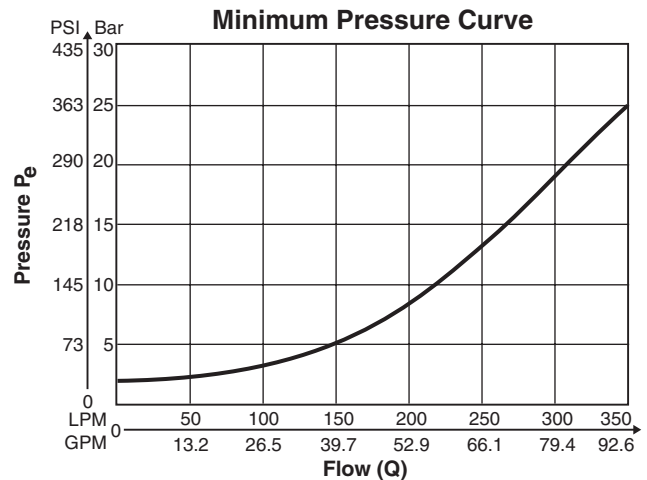
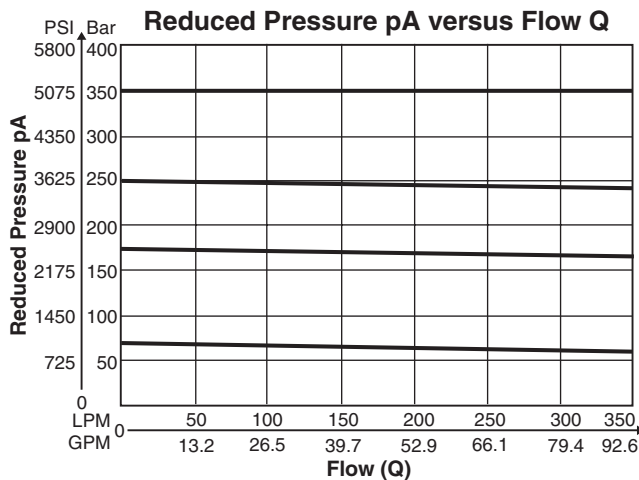

**PR32M\*W 1)**

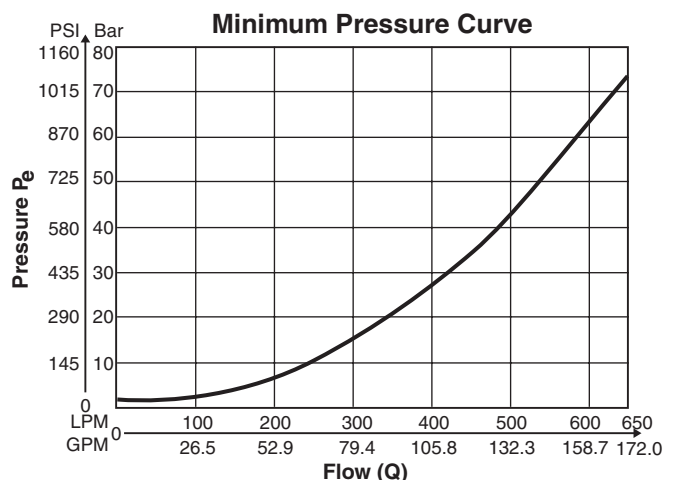
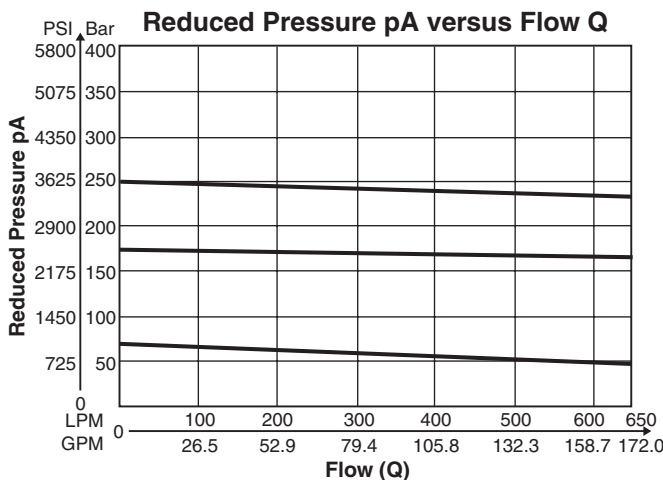

1) Measured at 350 Bar (5075 PSI) primary pressure pB.

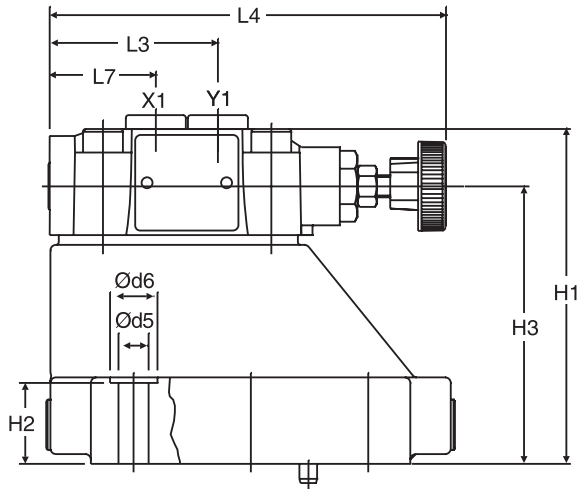
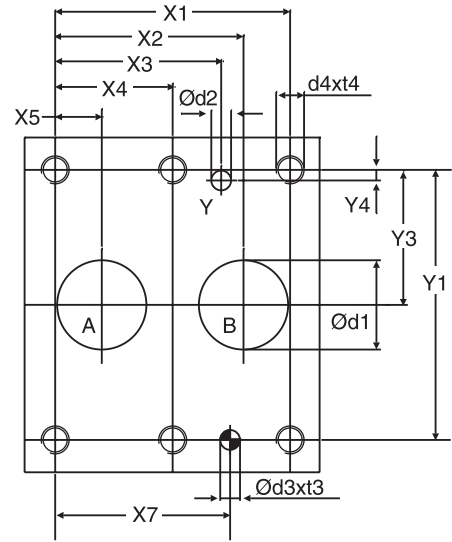
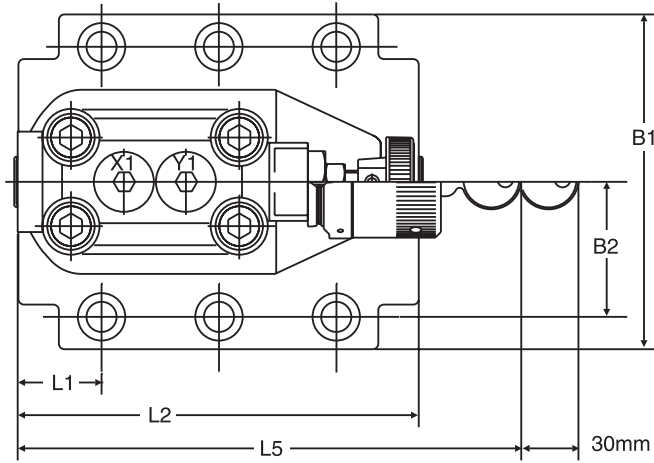

X1: G 1/4"  
Y1: G 1/4"



**Dimensions**

**Pilot Operated Pressure Reducing Valve  
Series PR\*M**





Inch equivalents for millimeter dimensions are shown in (\*\*)

NG	ISO-code	x1	x2	x3	x4	x5	x6	x7	y1	y2	y3	y4	y5	y6
10	5781-06-07-0-00	42.9 (1.69)	35.8 (1.41)	21.5 (0.85)	— —	7.2 (0.28)	— —	31.8 (1.25)	66.7 (2.63)	— —	33.4 (1.31)	7.9 (0.31)	— —	— —
25	5781-08-10-0-00	60.3 (2.37)	49.2 (1.94)	39.7 (1.56)	— —	11.1 (0.44)	— —	44.5 (1.75)	79.4 (3.13)	— —	39.7 (1.56)	6.4 (0.25)	— —	— —
32	5781-10-13-0-00	84.2 (3.31)	67.5 (2.66)	59.5 (2.34)	42.1 (1.66)	16.7 (0.66)	— —	62.7 (2.47)	96.8 (3.81)	— —	48.4 (1.92)	3.8 (0.15)	— —	— —

Tolerance for all dimensions ±0.2

NG	ISO-code	B1	B2	H1	H2	H3	H4	H5	H6	L1	L2	L3	L4	L5	L7
10	5781-06-07-0-00	87.3 (3.44)	33.4 (1.31)	83.0 (3.27)	21.0 (0.83)	62.5 (2.46)	— —	— —	— —	29.0 (1.14)	94.8 (3.73)	60.8 (2.39)	141.0 (5.55)	181.0 (7.13)	38.6 (1.52)
25	5781-08-10-0-00	105.0 (4.13)	39.7 (1.56)	109.5 (4.31)	29.0 (1.14)	89.0 (3.50)	— —	— —	— —	34.7 (1.37)	126.8 (4.99)	60.8 (2.39)	141.0 (5.55)	181.0 (7.13)	38.6 (1.52)
32	5781-10-13-0-00	120.0 (4.72)	48.4 (1.91)	120.0 (4.72)	29.0 (1.14)	99.5 (3.92)	— —	— —	— —	30.6 (1.20)	144.3 (5.68)	60.8 (2.39)	141.0 (5.55)	181.0 (7.13)	38.6 (1.52)

NG	ISO-code	d1max	d2max	d3	t3	d4	t4	d5	d6
10	5781-06-07-0-00	15.0 (0.59)	7.0 (0.28)	7.1 (0.28)	8.0 (0.31)	M10	16.0 (0.63)	10.8 (0.43)	17.0 (0.67)
25	5781-08-10-0-00	23.4 (0.92)	7.1 (0.28)	7.1 (0.28)	8.0 (0.31)	M10	18.0 (0.71)	10.8 (0.43)	17.0 (0.67)
32	5781-10-13-0-00	32.0 (1.26)	7.1 (0.28)	7.1 (0.28)	8.0 (0.31)	M10	20.0 (0.79)	10.8 (0.43)	17.0 (0.67)

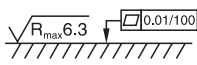
NG	ISO-code	Bolt kit  DIN912 12.9 	NBR  Kit 	Surface Finish 
10	5781-06-07-0-00	BK-M10 x 35-4pcs 63 Nm (46.5 lb.-ft.)	SK-PR10MN50 SK-PR10MV50	
25	5781-08-10-0-00	BK-M10 x 45-4pcs 63 Nm (46.5 lb.-ft.)	SK-PR25MN50 SK-PR25MV50	
32	5781-10-13-0-00	BK-M10 x 45-6pcs 63 Nm (46.5 lb.-ft.)	SK-PR32MN50 SK-PR32MV50	

### General Description

Series VM direct operated, pressure reducing valve with manual adjustment. Series VM is a direct-controlled, spring loaded 3-way pressure reducing valve, that is open in neutral position. The valve closes the connection from P to A (NG6) or B to A (NG10) when the pre-set pressure is exceeded.

If the pressure increases due to an external influence in connection A, the spool moves and opens the connection from A to T (NG6) or A to Y (NG10) until the pre-set pressure is reached.

### Features

- Spool type valve.
- Manifold mounting acc. to ISO 5871.
- 4 pressure ranges at NG6.
- 3 pressure ranges at NG10.
- 2 adjustment modes.

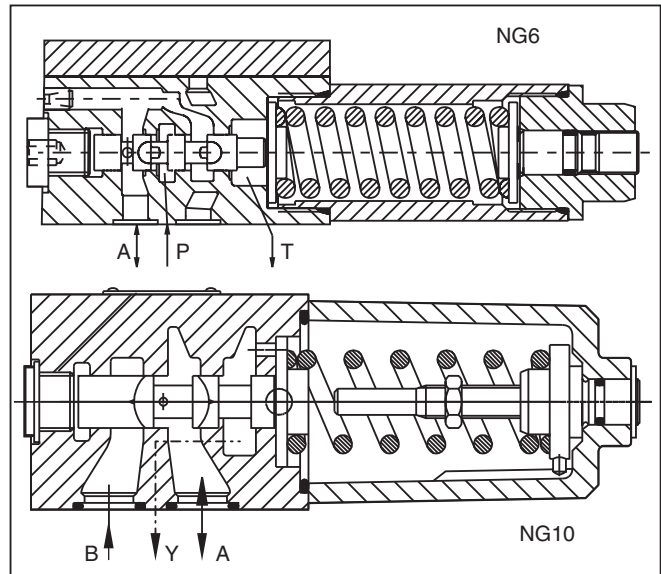
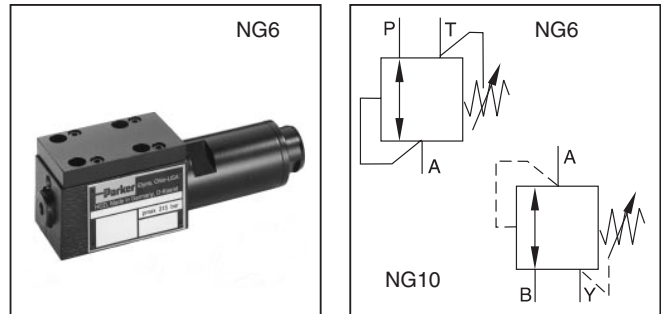

### Specifications

General		NG6	NG10
Size			
Interface		Subplate mounting acc. ISO 5781	
Mounting Position		Unrestricted	
Ambient Temperature		-20°C to +70° (-4°F to +158°F)	
Hydraulic			
Working Pressure		Ports P and A 210 Bar (3045 PSI) Port T depressurized	Ports A and B 210 Bar (3045 PSI) Port Y depressurized
Pressure Range		25, 64, 160, 210, 350 Bar (363, 928, 2320, 3045, 5075 PSI)	64, 125, 210 Bar (928, 1813, 3045 PSI)
Nominal Flow		25 LPM (6.6 GPM)	60 LPM (15.9 GPM)
Pressure Fluid		Hydraulic oil according to DIN 51524 ... 525	
Viscosity	Recommended Permitted	30 to 50 cSt (mm <sup>2</sup> /s) 20 to 380 cSt (mm <sup>2</sup> /s)	
Pressure Fluid Temperature	Recommended Permitted	+30°C to +50°C (+86°F to +122°F) -20°C to +70° (-4°F to +158°F)	
Filtration		ISO 4406 (1999), 18/16/13	



**V**

**M**

Pressure Reducing Valve

Maximum Pressure Setting

**A**

Adjustment Screw with Hexagon Socket

Size

**V**

Seal

Gage Port

Lock

Code	Description
025 <sup>1)</sup>	25 Bar (363 PSI)
064	64 Bar (928 PSI)
125 <sup>2)</sup>	125 Bar (1813 PSI)
160 <sup>1)</sup>	160 Bar (2320 PSI)
210	210 Bar (3045 PSI)
350 <sup>1)</sup>	350 Bar (5075 PSI)

- <sup>1)</sup> NG6 only
- <sup>2)</sup> NG10 only

Code	Description
V	Fluorocarbon

Code	Description
Omit	Normal
Z	Cylinder Lock

Code	Description
06	NG6
10	NG10

Code	Description
G <sup>1)</sup>	G 1/4"
M	M18x1.5 <sup>2)</sup> M12x1.5 <sup>1)</sup>
C <sup>1)</sup>	Coupling M16

- <sup>1)</sup> NG6 only

**Weight:**

VM*A06	1.3 kg (2.9 lbs.)
VM*A10	3.7 kg (8.2 lbs.)

**NG6**

**Maximum Pressure Setting  
 25 Bar (363 PSI)**

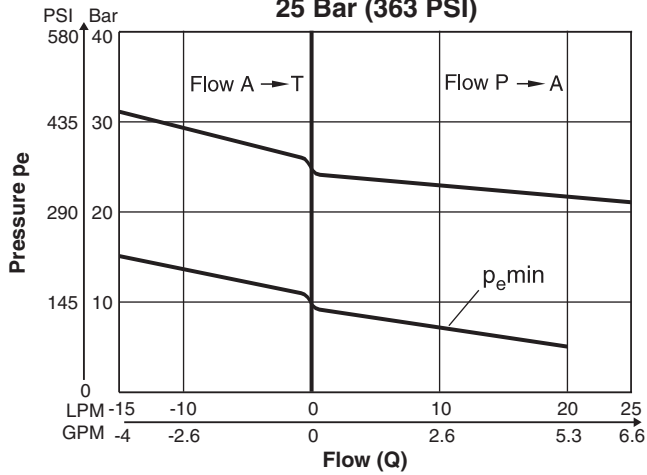

**Maximum Pressure Setting  
 64 Bar (928 PSI)**

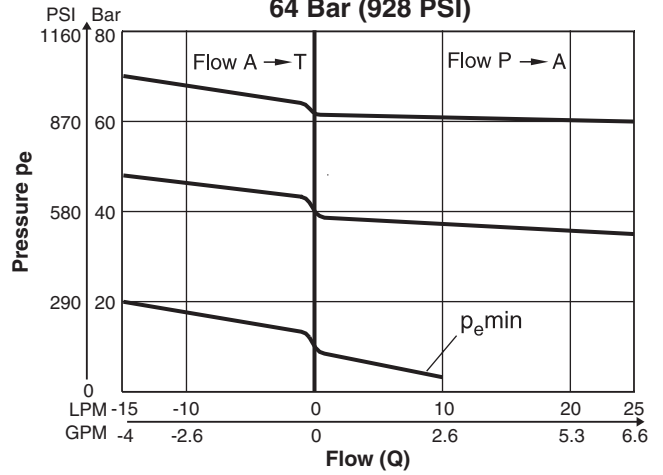

**Maximum Pressure Setting  
 160 Bar (2320 PSI) or 210 Bar (3045 PSI)**

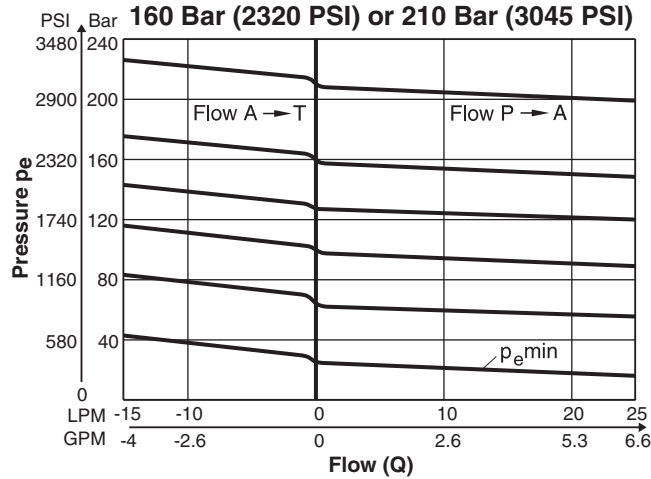

**NG10**

**Maximum Pressure Setting  
 64 Bar (928 PSI)**

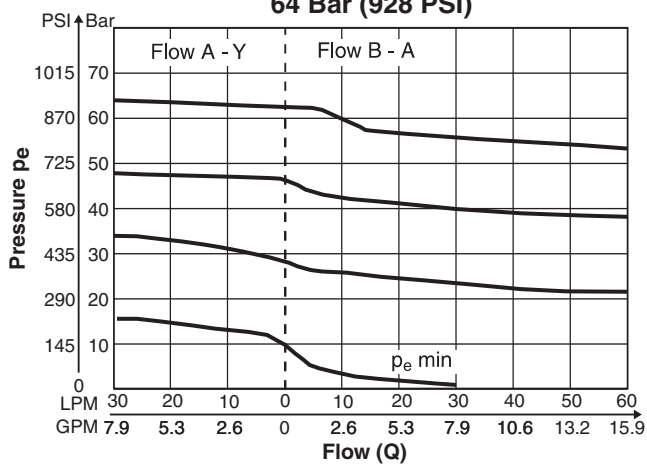

**Maximum Pressure Setting  
 210 Bar (3045 PSI)**

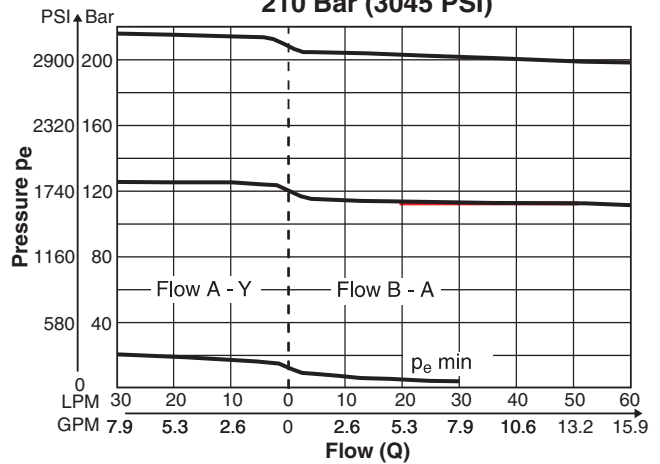

VM.indd, dd

**NG6**

Inch equivalents for millimeter dimensions are shown in (\*\*)

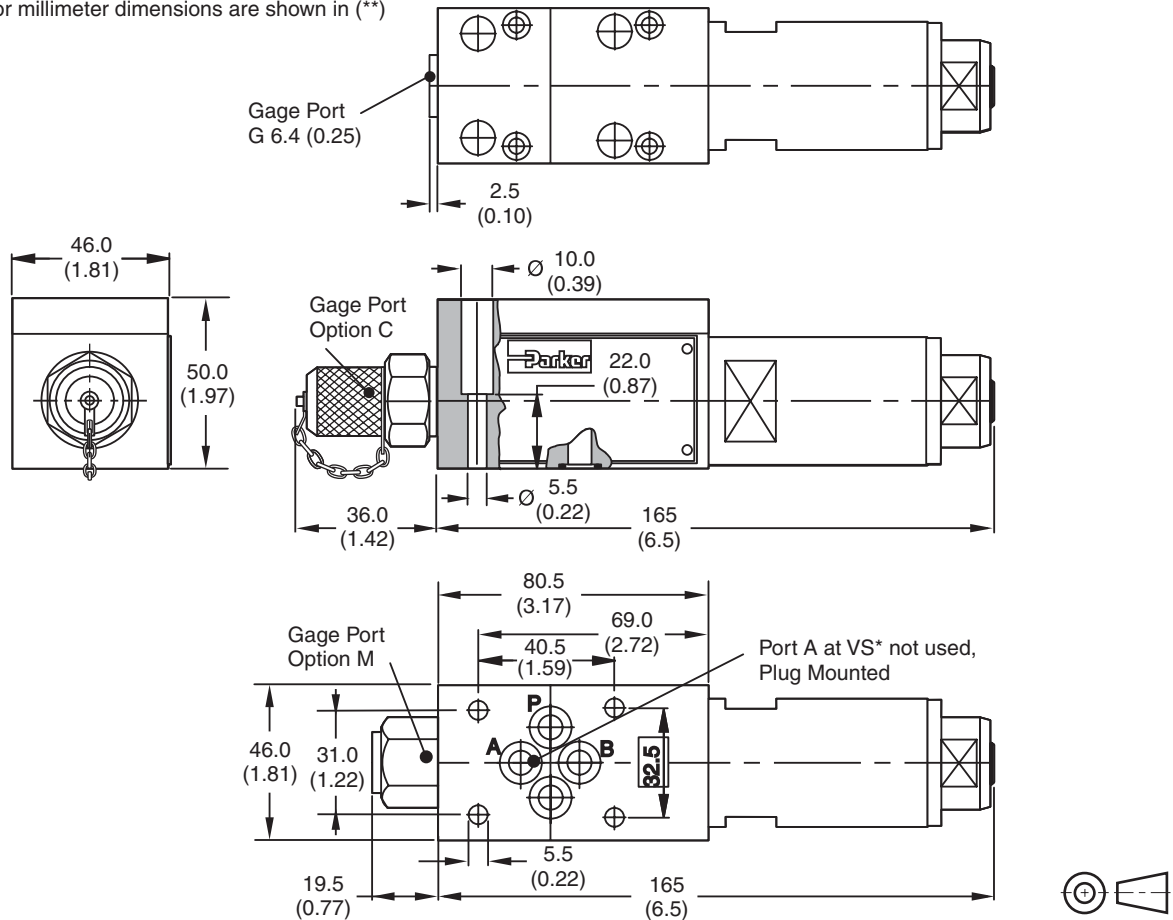

<b>Surface finish</b>	<b>Bolt kit</b> <b>DIN912 12.9</b>		<b>Kit FPM</b>
	BK-M5x30-4pcs	8.1 Nm (6.0 lb.-ft.)	SK-VB/VM/VS-A06V

**Mounting Pattern ISO 5871-03-04-0-00**

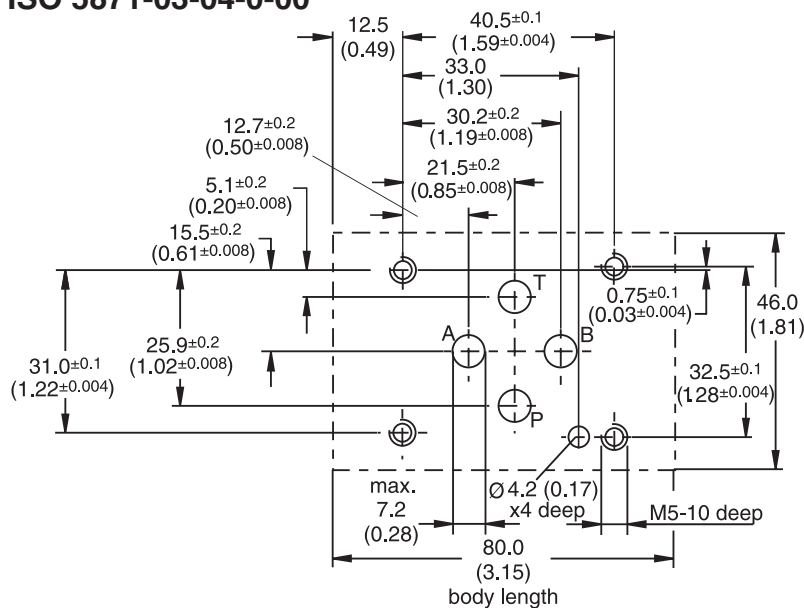



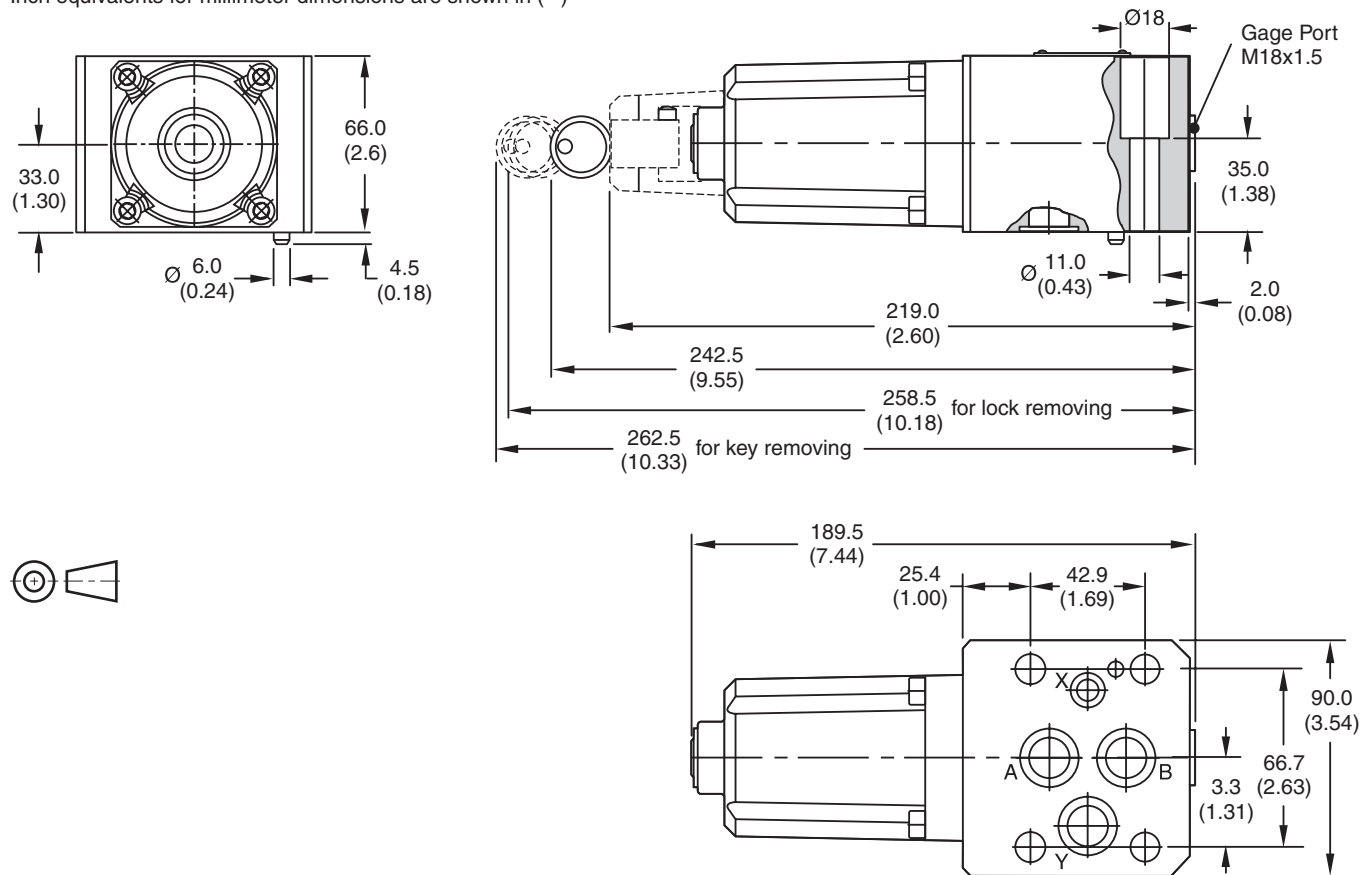

VM.indd, dd

**NG10**

Inch equivalents for millimeter dimensions are shown in (\*\*)



Surface finish	Bolt kit  DIN912 12.9		 Kit FPM
	BK-M10x50-4pcs	65 Nm (47.9 lb.-ft.)	SK-VB/VM-A10V

**Mounting Pattern ISO 5871-06-07-0-00**

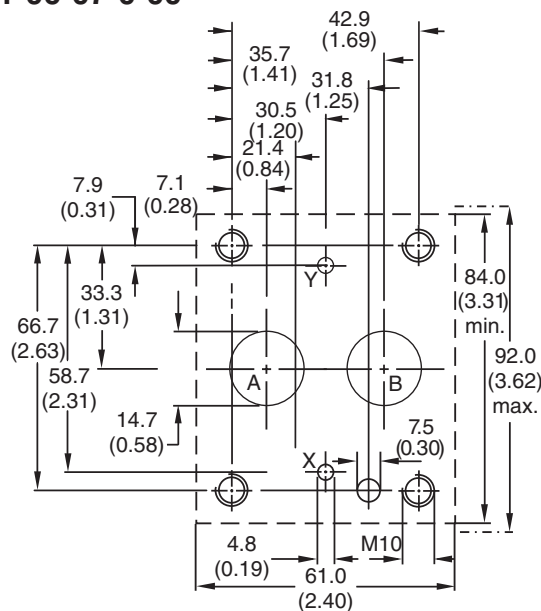

**General Description**

Series S\*M pilot operated sequence valves enable a hydraulic system to operate in a pressure sequence. When the system pressure reaches the setting pressure the valve opens and permits flow to the secondary sub-system.

**Features**

- Pilot-operated sequence valve.
- 2 interfaces
  - Subplate mounting acc. to ISO 5781
  - Slip-in mounting acc. to ISO 7368
- 4 pressure ranges.
- 3 adjustment modes.
  - Hand knob
  - Screw with hexagon socket
  - DIN knob

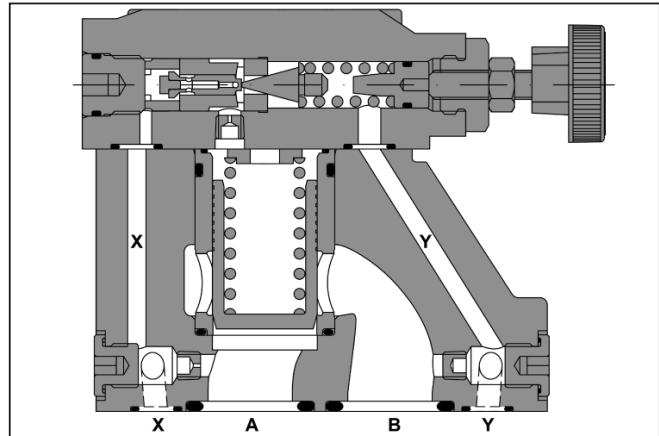
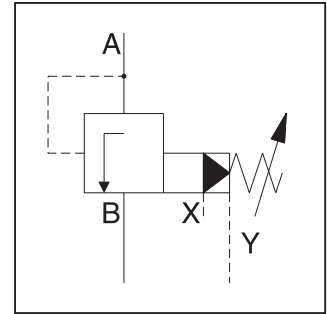
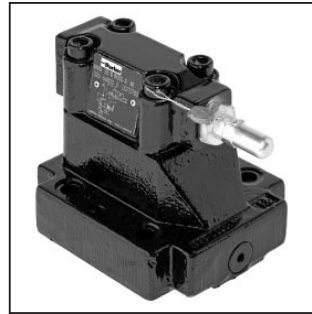

**Specifications**

General		NG10	NG25	NG32
<b>Size</b>				
<b>Interface</b>	Subplate mounting acc. ISO 5781			
<b>Mounting Position</b>	As desired, horizontal mounting preferred			
<b>Ambient Temperature</b>	-20°C to +80°C (-4°F to +176°F)			
Hydraulic				
<b>Operating Pressure</b>	Ports A and X up to 350 Bar (5075 PSI), connection B and Y depressurized			
<b>Pressure Range</b>	75, 175, 250, 350 Bar (1088, 2538, 3625, 5075 PSI)			
<b>Nominal Flow</b>	150 LPM (39.7 GPM)	350 LPM (92.6 GPM)	650 LPM (172.0 GPM)	
<b>Pressure Fluid</b>	Hydraulic oil according to DIN 51524 ... 525			
<b>Viscosity</b>	<b>Recommended</b> 30 to 50 cSt (mm <sup>2</sup> /s)	<b>Maximum</b> 20 to 380 cSt (mm <sup>2</sup> /s)		
<b>Pressure Fluid Temperature</b>	<b>Recommended</b> +30°C to +50°C (+86°F to +122°F) <b>Maximum</b> -20°C to +70° (-4°F to +158°F)			
<b>Filtration</b>	ISO 4406 (1999), 18/16/13			

**Ordering Information**

<b>S</b>	□	<b>M</b>	□	□	□	<b>U</b>	□
Sequence Valve	Size	Interface	Pressure Range	Adjustment	Pilot Oil	Poppet Spring	Seals

Code	Description
07	70 Bar (1015 PSI)
17	175 Bar (2538 PSI)
25	250 Bar (3625 PSI)
35	350 Bar (5075 PSI)

Code	Description
N	Nitrile
V	Fluorocarbon

Code	Pilot	Drain
1	Internal	External
2	External	External

Code	Description
L	DIN lock
S	Hand knob

Code	Size	Mounting
10	NG10	Subplate
25	NG25	mounting
32	NG32	

Code	Interface
M	Subplate mounting ISO 5781

**Weight:**

S10M	2.7 kg (6.0 lbs.)
S25M	4.5 kg (9.9 lbs.)
S32M	6.0 kg (13.2 lbs.)

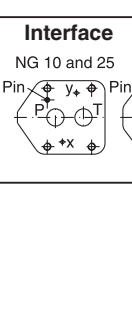
**Performance Curves**

Typical pressure curves at closing point

P1 = setting pressure

P2 = operating pressure

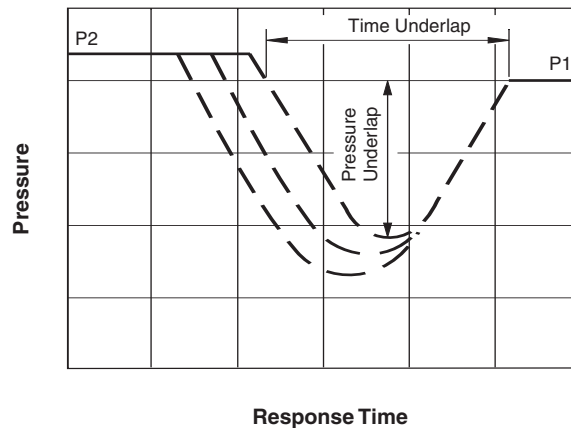

Note:  
 Time and pressure underlap depend on the characteristics of a specific system.

**Dimensions**

**Pilot Operated Sequence Valve  
Series S\*M**

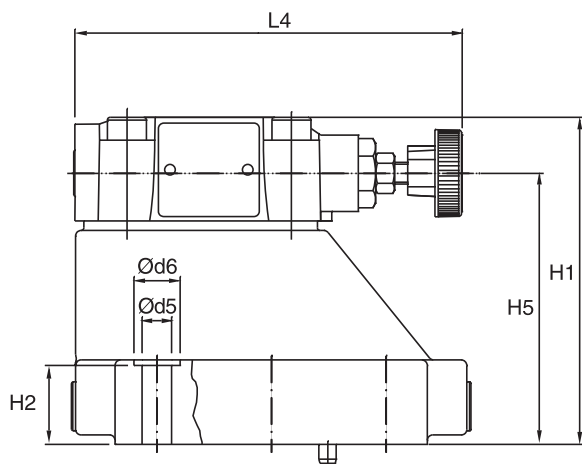
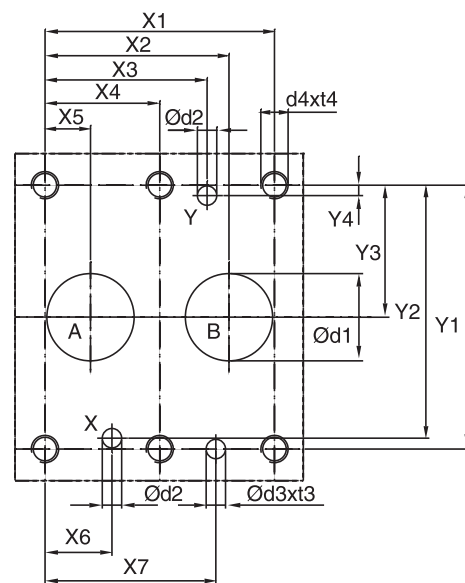
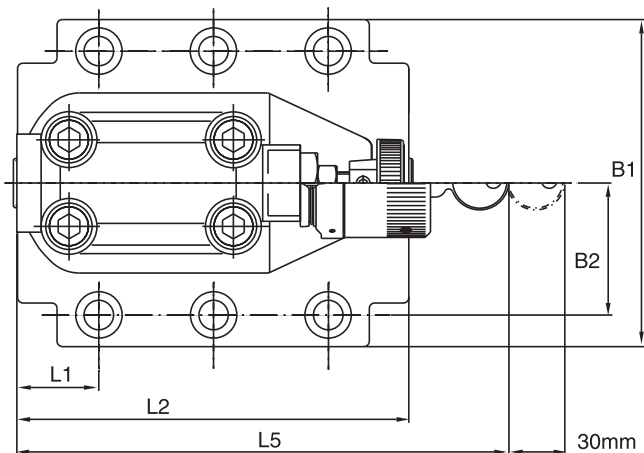

**Dimensions**

**Pilot Operated Sequence Valve  
Series S\*M**



Inch equivalents for millimeter dimensions are shown in (\*\*)

NG	ISO-code	x1	x2	x3	x4	x5	x6	x7	y1	y2	y3	y4	y5	y6
10	5781-06-07-0-00	42.9 (1.69)	35.8 (1.41)	21.5 (0.85)	–	7.2 (0.28)	21.5 (0.85)	31.8 (1.25)	66.7 (2.63)	58.8 (2.31)	33.4 (1.31)	7.9 (0.31)	–	–
25	5781-08-10-0-00	60.3 (2.37)	49.2 (1.94)	39.7 (1.56)	–	11.1 (0.44)	20.6 (0.81)	44.5 (1.75)	79.4 (3.13)	73.0 (2.87)	39.7 (1.56)	6.4 (0.25)	–	–
32	5781-10-13-0-00	84.2 (3.31)	67.5 (2.66)	59.5 (2.34)	42.1 (1.66)	16.7 (0.66)	24.6 (0.97)	62.7 (2.47)	96.8 (3.81)	92.8 (3.65)	48.4 (1.91)	3.8 (0.15)	–	–

Tolerance at X and Y pin holes and screw holes ±0.1, at port holes ±0.2.

NG	ISO-code	B1	B2	H1	H2	H3	H4	H5	H6	L1	L2	L3	L4	L5	L6
10	5781-06-07-0-00	87.3 (3.44)	33.4 (1.31)	83.0 (3.27)	21.0 (0.83)	62.5 (2.46)	–	–	–	29.0 (1.14)	94.8 (3.73)	–	141.0 (5.55)	181.0 (7.13)	–
25	5781-08-10-0-00	105.0 (4.13)	39.7 (1.56)	109.5 (4.31)	29.0 (1.14)	89.0 (3.50)	–	–	–	34.7 (1.37)	126.8 (4.99)	–	141.0 (5.55)	181.0 (7.13)	–
32	5781-10-13-0-00	120.0 (4.72)	48.4 (1.91)	120.0 (4.72)	29.0 (1.14)	99.5 (3.92)	–	–	–	30.6 (1.20)	144.3 (5.68)	–	141.0 (5.55)	181.0 (7.13)	–

NG	ISO-code	d1max	d2max	d3	t3	d4	t4	d5	d6
10	5781-06-07-0-00	15.0 (0.59)	7.0 (0.28)	7.1 (0.28)	8.0 (0.31)	M10	16.0 (0.63)	10.8 (0.43)	17.0 (0.67)
25	5781-08-10-0-00	23.4 (0.92)	7.1 (0.28)	7.1 (0.28)	8.0 (0.31)	M10	18.0 (0.71)	10.8 (0.43)	17.0 (0.67)
32	5781-10-13-0-00	32.0 (1.26)	7.1 (0.28)	7.1 (0.28)	8.0 (0.31)	M10	20.0 (0.79)	10.8 (0.43)	17.0 (0.67)

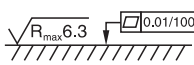
NG	ISO-code	Bolt kit  DIN912 12.9		NBR  Kit FPM	Surface finish 
10	5781-06-07-0-00	BK-M10 x 35-4pcs	63 Nm (46.5 lb.-ft.)	SK-UR10MN50 SK-UR10MV50	
25	5781-08-10-0-00	BK-M10 x 45-4pcs	63 Nm (46.5 lb.-ft.)	SK-UR25MN50 SK-UR25MV50	
32	5781-10-13-0-00	BK-M10 x 45-6pcs	63 Nm (46.5 lb.-ft.)	SK-UR32MN50 SK-UR32MV50	



**General Description**

Series VB are direct operated pressure relief valves with manual adjustment. Series VB valves can also be used as pressure sequence valves because of the high pressure capability in the outlet port and the external drain port.

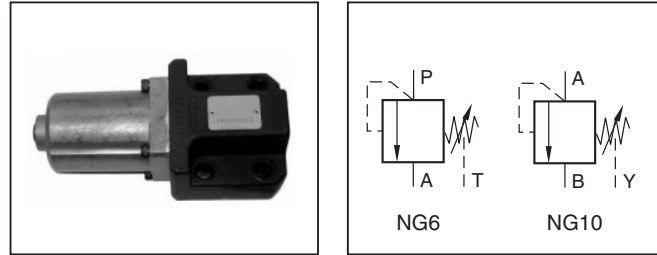

**Specifications**

<b>Size</b>	NG6, NG10
<b>Interface</b>	ISO 5791
<b>Mounting Pos.</b>	Unrestricted
<b>Ambient Temp.</b>	-20°C to +70°C (-4°F to +158°F)
<b>Max. Operating Pressure</b>	Size 6: Ports P and A 210 Bar (3045 PSI), Port T depressurized  Size 10: Ports A and B 210 Bar (3045 PSI), Port Y depressurized
<b>Pressure Range</b>	Size 6: 25, 64, 160, 210, 350 Bar (363, 928, 2320, 3045, 5075 PSI) Size 10: 64, 125, 210 Bar (928, 1813, 3045 PSI)
<b>Nominal Flow</b>	Size 6: 25 LPM (6.6 GPM) Size 10: 60 LPM (15.9 GPM)
<b>Pressure Fluid</b>	Hydraulic oil according to DIN 51524 ... 525
<b>Pressure Fluid Temperature</b>	Recommended: +30C to +50°C (+86°F to +122°F) Permitted: -20°C to +70°C (-4°F to +158°F)
<b>Viscosity</b>	Recommended: 30 to 50 cSt (mm²/s) Permitted: 20 to 380 cSt (mm²/s)
<b>Filtration</b>	ISO 4406 (1999), 18/16/13

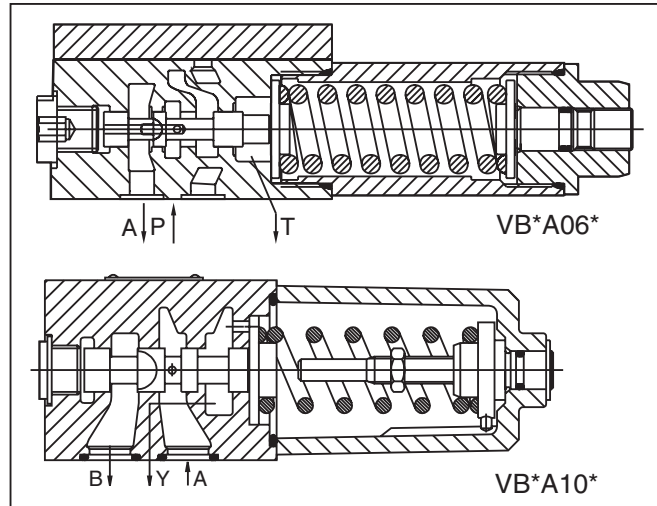

**Features**

- Spool valve.
- Manifold mounting.
- Five pressure ranges at NG06.
- Three pressure ranges at NG10.
- Two adjustment modes.

**Ordering Information**

<div style="border: 1px solid black; padding: 2px; width: 30px; margin: 0 auto;">VB</div> <p style="text-align: center; font-size: small;">Sequence Valve</p>	<div style="border: 1px solid black; width: 30px; height: 30px; margin: 0 auto;"></div> <p style="text-align: center; font-size: small;">Maximum Setting Pressure</p>	<div style="border: 1px solid black; padding: 2px; width: 30px; margin: 0 auto;">A</div> <p style="text-align: center; font-size: small;">Adjustment Screw with Hexagon Socket</p>	<div style="border: 1px solid black; width: 30px; height: 30px; margin: 0 auto;"></div> <p style="text-align: center; font-size: small;">Nominal Size</p>	<div style="border: 1px solid black; padding: 2px; width: 30px; margin: 0 auto;">V</div> <p style="text-align: center; font-size: small;">Seal</p>	<div style="border: 1px solid black; width: 30px; height: 30px; margin: 0 auto;"></div> <p style="text-align: center; font-size: small;">Gauge Port</p>	<div style="border: 1px solid black; width: 30px; height: 30px; margin: 0 auto;"></div> <p style="text-align: center; font-size: small;">Lock</p>																																					
<table border="0" style="width: 100%; font-size: x-small;"> <tr><th>Code</th><th>Description</th></tr> <tr><td>025<sup>1)</sup></td><td>25 Bar (363 PSI)</td></tr> <tr><td>064</td><td>64 Bar (938 PSI)</td></tr> <tr><td>125<sup>2)</sup></td><td>125 Bar (1813 PSI)</td></tr> <tr><td>160<sup>1)</sup></td><td>160 Bar (2320 PSI)</td></tr> <tr><td>210<sup>1)</sup></td><td>210 Bar (3045 PSI)</td></tr> <tr><td>350<sup>1)</sup></td><td>350 Bar (5075 PSI)</td></tr> </table>	Code	Description	025 <sup>1)</sup>	25 Bar (363 PSI)	064	64 Bar (938 PSI)	125 <sup>2)</sup>	125 Bar (1813 PSI)	160 <sup>1)</sup>	160 Bar (2320 PSI)	210 <sup>1)</sup>	210 Bar (3045 PSI)	350 <sup>1)</sup>	350 Bar (5075 PSI)	<table border="0" style="width: 100%;"> <tr><th>Code</th><th>Description</th></tr> <tr><td>06</td><td>NG6</td></tr> <tr><td>10</td><td>NG 10</td></tr> </table>	Code	Description	06	NG6	10	NG 10	<table border="0" style="width: 100%;"> <tr><th>Code</th><th>Description</th></tr> <tr><td>G<sup>1)</sup></td><td>G 1/4"</td></tr> <tr><td>M</td><td>M12x1.5</td></tr> <tr><td>C<sup>1)</sup></td><td>Coupling M16</td></tr> </table> <p style="font-size: x-small; margin-top: 5px;"><sup>1)</sup> only NG06</p>	Code	Description	G <sup>1)</sup>	G 1/4"	M	M12x1.5	C <sup>1)</sup>	Coupling M16	<table border="0" style="width: 100%;"> <tr><th>Code</th><th>Description</th></tr> <tr><td>Omit</td><td>Normal</td></tr> <tr><td>Z</td><td>Cylinder Lock</td></tr> </table>	Code	Description	Omit	Normal	Z	Cylinder Lock	<table border="0" style="width: 100%;"> <tr><th>Code</th><th>Description</th></tr> <tr><td>V</td><td>Fluorocarbon</td></tr> </table>	Code	Description	V	Fluorocarbon	
Code	Description																																										
025 <sup>1)</sup>	25 Bar (363 PSI)																																										
064	64 Bar (938 PSI)																																										
125 <sup>2)</sup>	125 Bar (1813 PSI)																																										
160 <sup>1)</sup>	160 Bar (2320 PSI)																																										
210 <sup>1)</sup>	210 Bar (3045 PSI)																																										
350 <sup>1)</sup>	350 Bar (5075 PSI)																																										
Code	Description																																										
06	NG6																																										
10	NG 10																																										
Code	Description																																										
G <sup>1)</sup>	G 1/4"																																										
M	M12x1.5																																										
C <sup>1)</sup>	Coupling M16																																										
Code	Description																																										
Omit	Normal																																										
Z	Cylinder Lock																																										
Code	Description																																										
V	Fluorocarbon																																										

**Weight:**  
 VB\*A06 1.3 kg (2.9 lbs.)  
 VB\*A10 3.7 kg (8.2 lbs.)

**VB\*6**

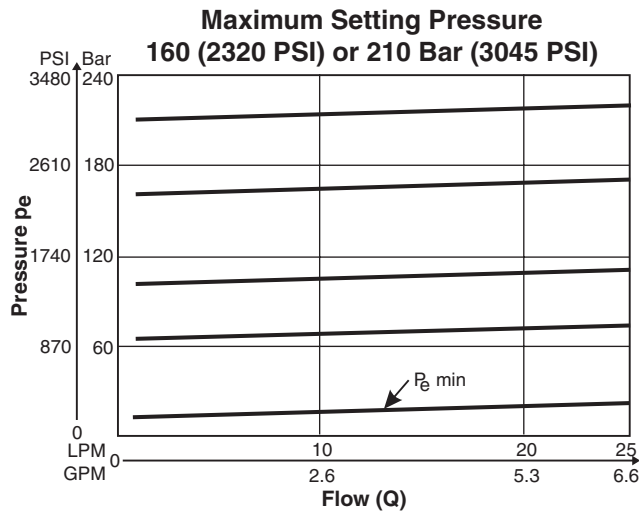
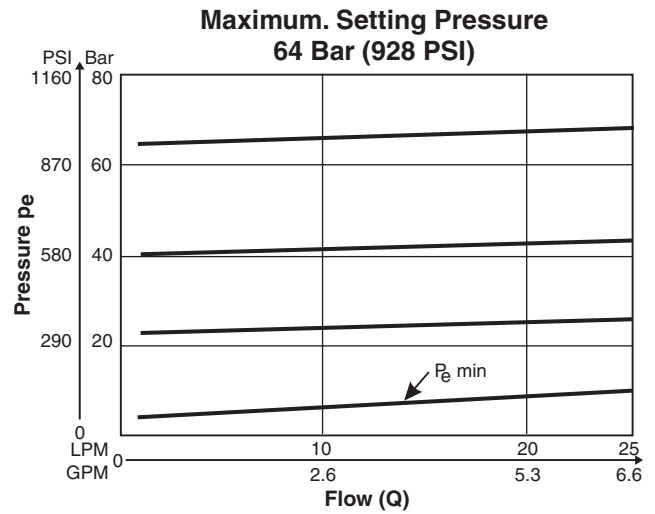
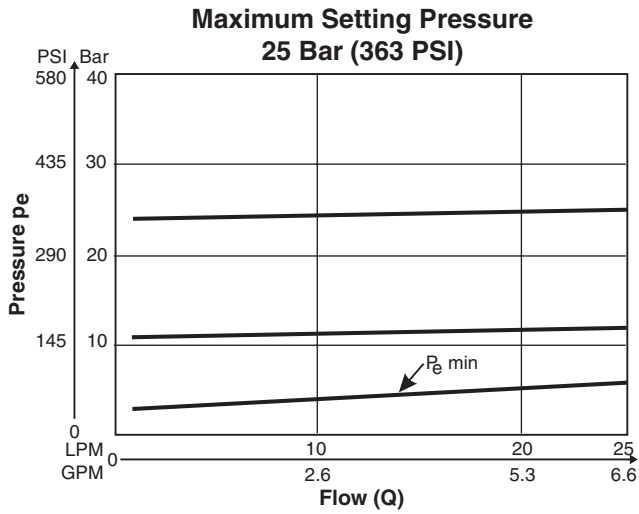

**VB\*10**

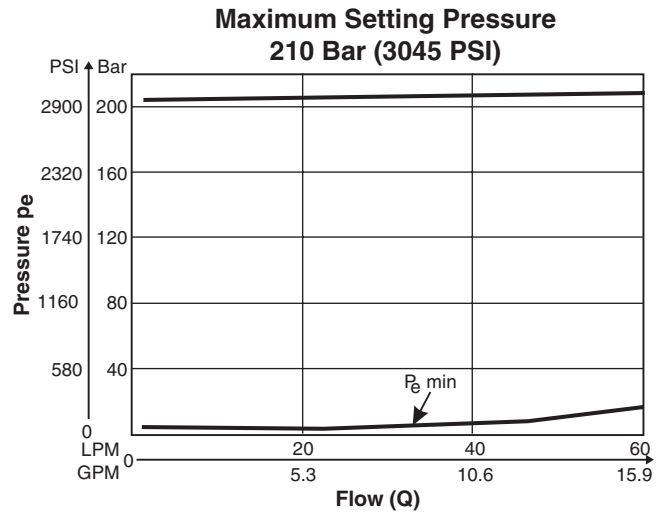
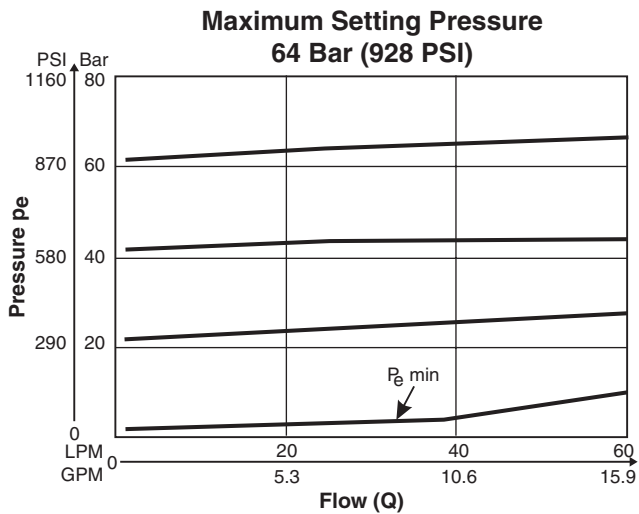

VB.indd, dd

**NG6**

Inch equivalents for millimeter dimensions are shown in (\*\*)

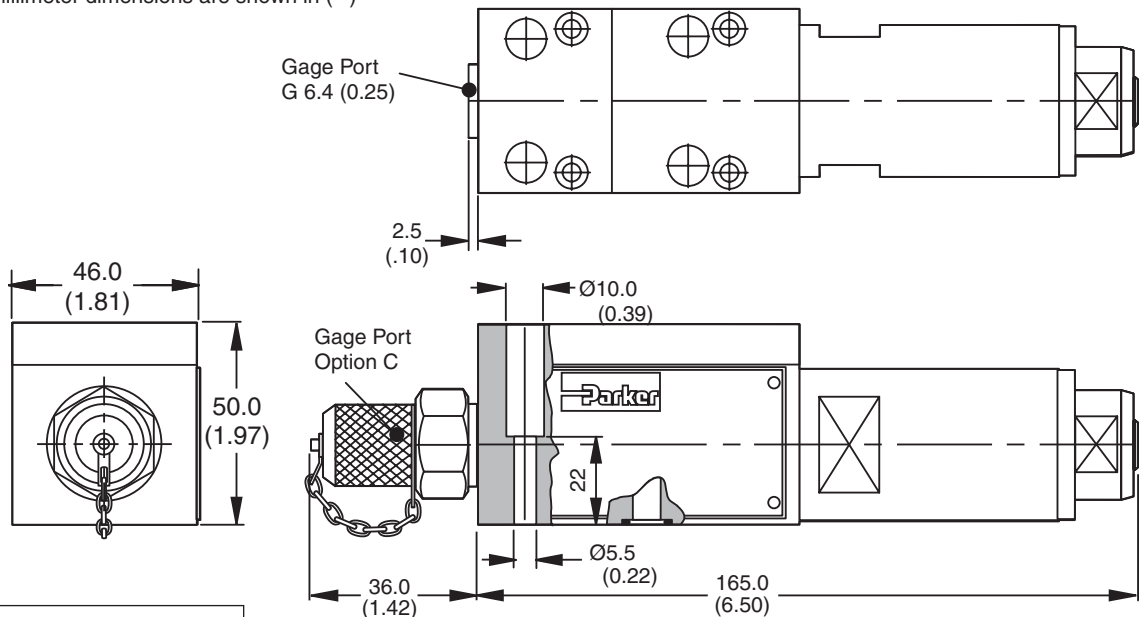

<b>Surface Finish</b>	$\sqrt{R_{max}6.3}$ $\square 0.01/100$
<b>Bolt Kit</b> DIN912 12.9	SK-M5x30-4pcs
	8.1 Nm
<b>Kit FPM</b>	SK-VB/VM/VS-A06V

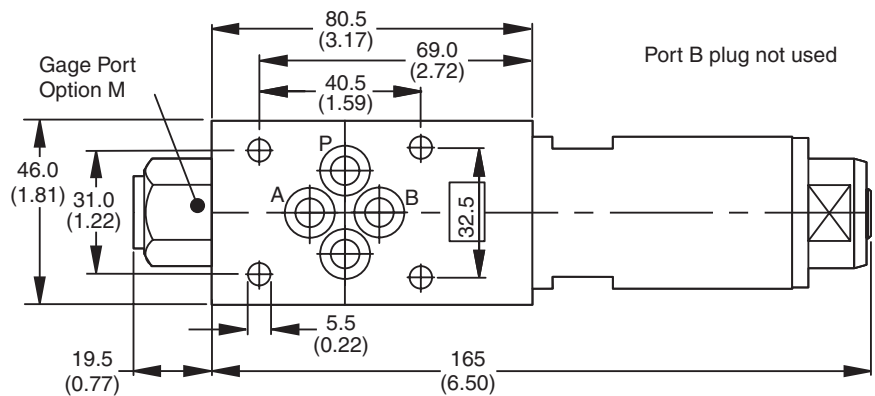

**Mounting Pattern ISO 5781-03-04-0-00**

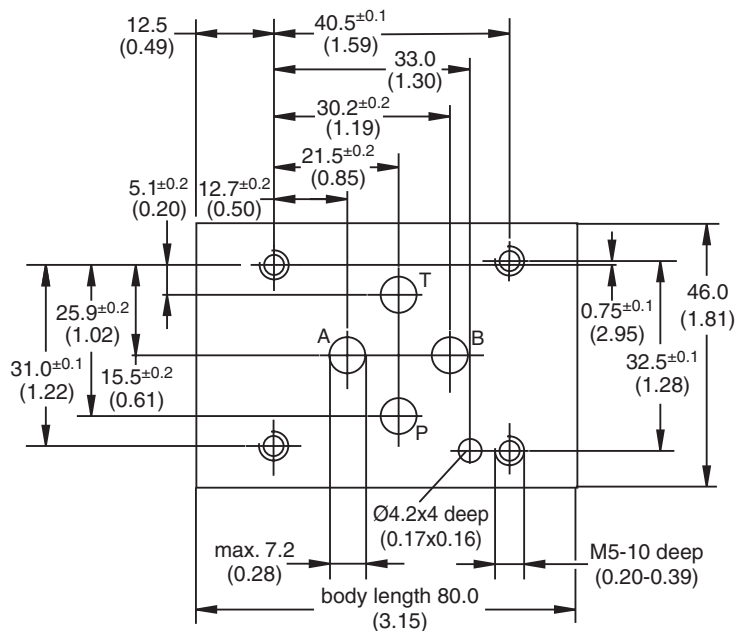

VB.indd, dd





**General Description**

Series VBY pilot operated sequence valves consist of a pilot with manual adjustment and a main part with spool execution. The valve has an external drain.

This valve can also be used as a pressure relief valve. Please observe hydraulic connection.

**Features**

- Manifold mounting acc. to ISO 5781.
- Type VBY with external drain.
- Main stage spool type valve.
- Pilot stage seated type valve.
- 4 pressure ranges.
- 2 adjustment modes
  - Screw with hexagon socket
  - DIN knob

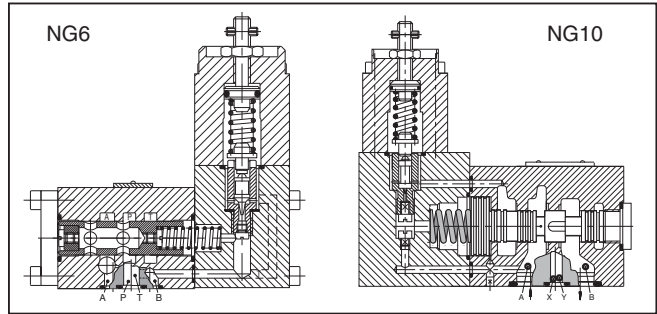
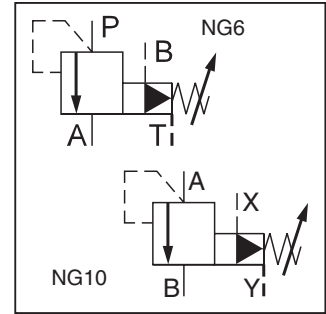

**Specifications**

Size	NG6	NG10
Mounting Pattern	ISO 5781	
Mounting Position	As desired	
Ambient Temperature	+50°C (+122°F) Maximum	
Operating Pressure, Ports External Drain Port Pressure	P, A, B up to 315 Bar (4568 PSI) T up to 100 Bar (1450 PSI)	A, B, X up to 315 Bar (4568 PSI) Y up to 100 Bar (1450 PSI)
Pressure Range	64, 160, 210, 315 Bar (928, 2320, 3045, 4568 PSI)	
Pressure Fluid Temperature	+70°C (158°F) Maximum	
Viscosity Range	30 to 230 cSt (mm <sup>2</sup> /s)	
Filtration	ISO 4406 (1999), 18/16/13	
Pilot Oil Flow	approx. 500 cm <sup>3</sup> /min	approx. 1000 cm <sup>3</sup> /min

**Ordering Information**

**VBY**

Pressure Relief Valve

□

Pressure Range

□

Operation

□

Valve Size

□

Seal

Code	Description
064	64 Bar (928 PSI)
160	160 Bar (2320 PSI)
210	210 Bar (3045 PSI)
315	315 Bar (4568 PSI)

Code	Description
A	Adjustment Screw with Hexagon Socket
H	Turning Knob with Cylinder Lock

Code	Description
06	NG6
10	NG10

Code	Description
N	Nitrile
V	Fluorocarbon

**Weight:**

- VBY\*06 2.4 kg (5.29 lbs.)
- VBY\*10 4.5 kg (9.92 lbs.)

**NG6**

p/Q measured at t = 50°C (122°F) and v = 36mm<sup>2</sup>/s

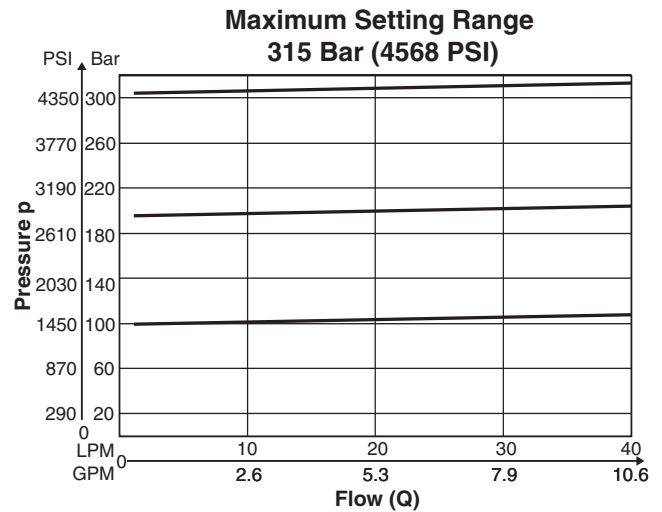
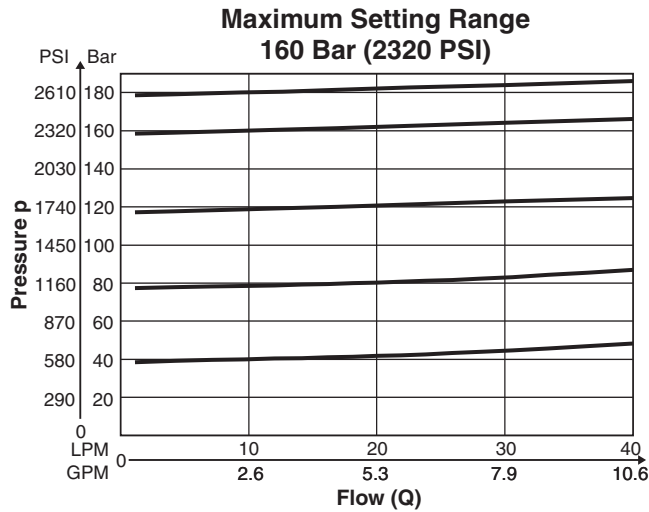
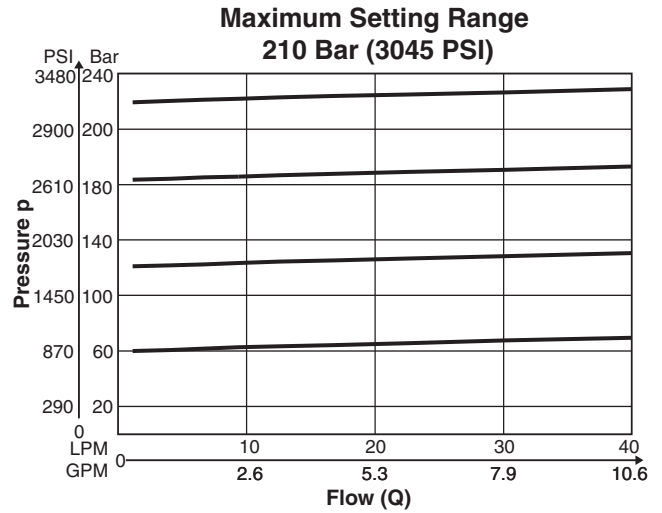
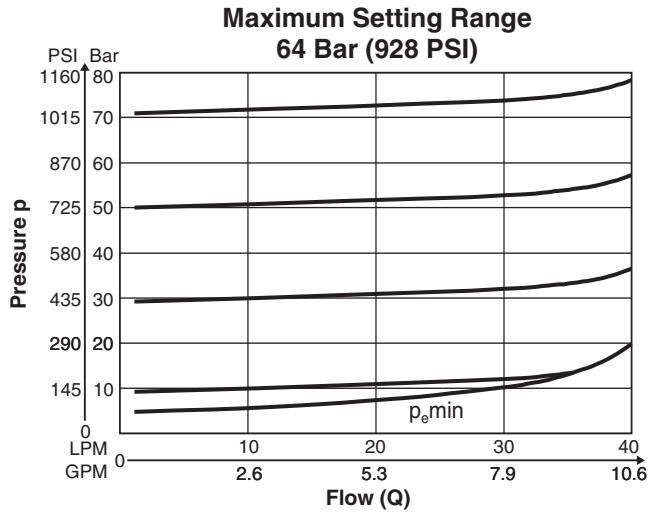

**NG10**

p/Q measured at t = 50°C (122°F) and v = 36mm<sup>2</sup>/s

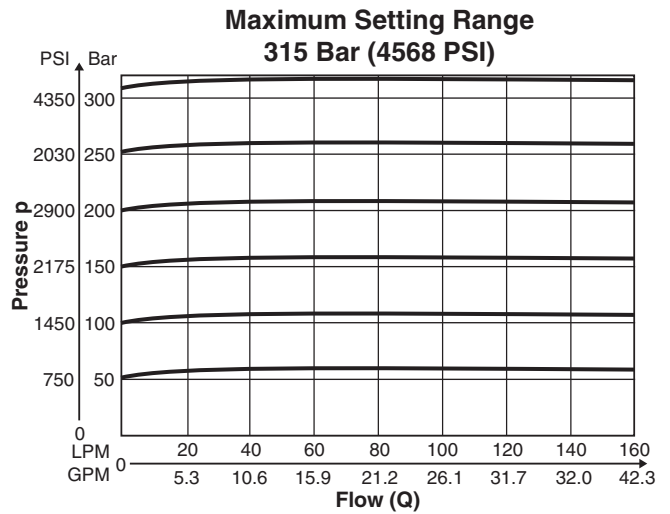
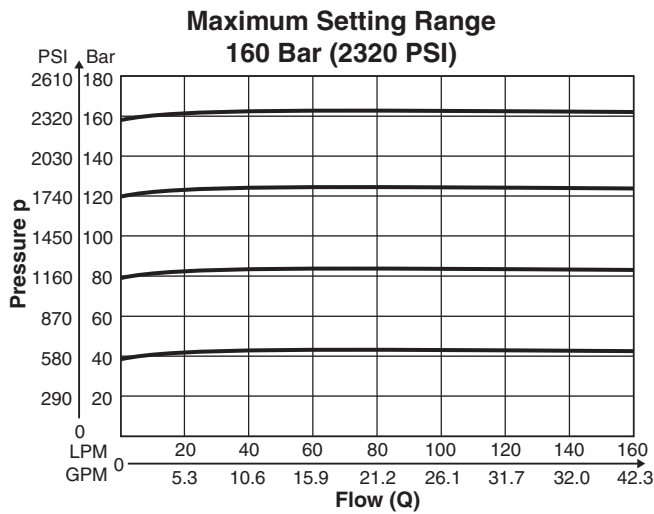
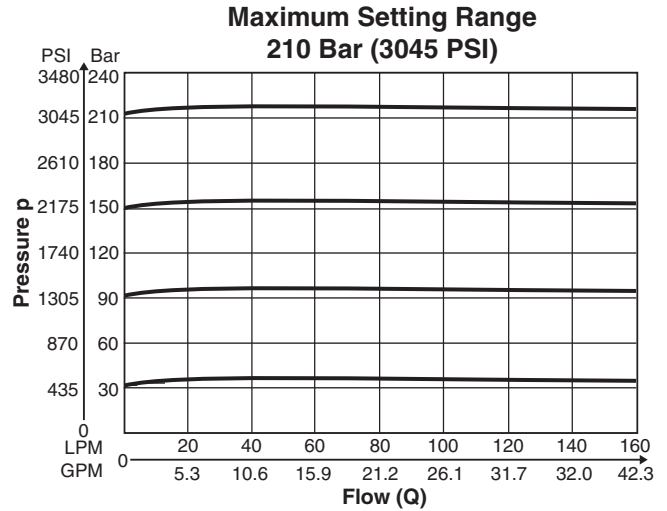
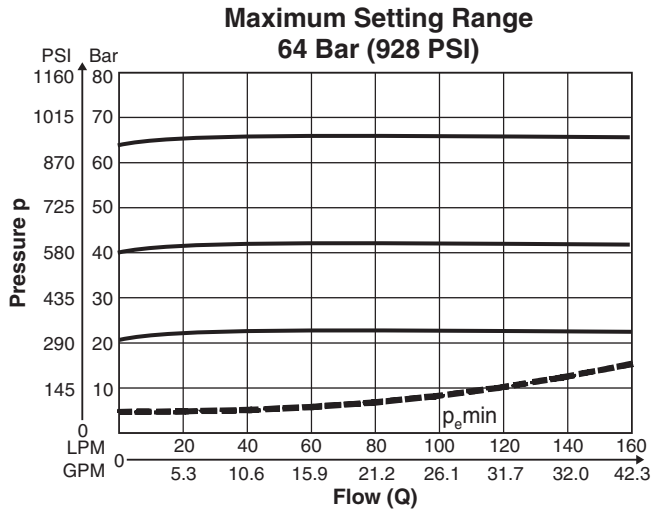

**NG6**

Inch equivalents for millimeter dimensions are shown in (\*\*)

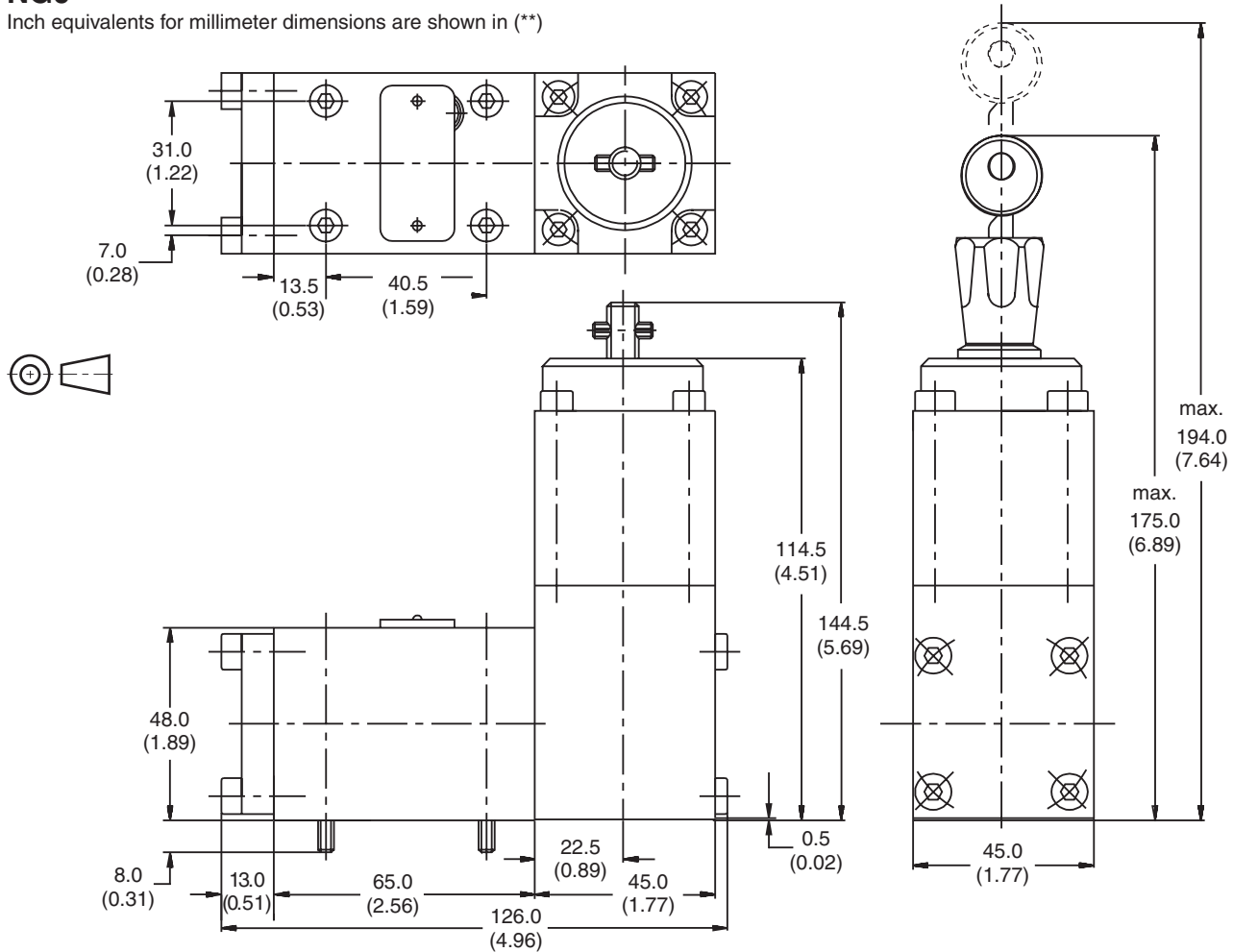

<b>Surface finish</b>	<b>Bolt kit</b> <b>DIN912 12.9</b>		<b>Kit FPM</b>
	BK-M5x30-4pcs	7.5 Nm (5.5 lb.-ft.)	SK-VBY-A06V

**Mounting Pattern ISO 5781-03-04-0-00**

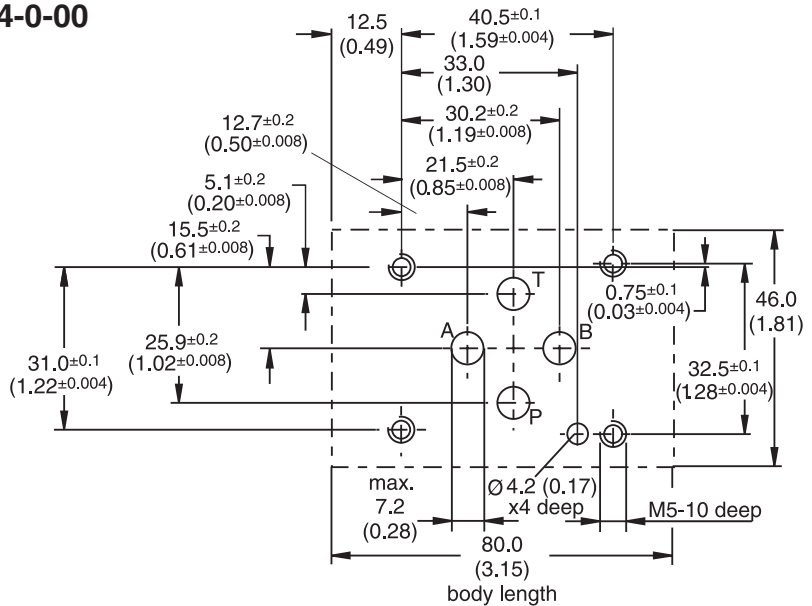





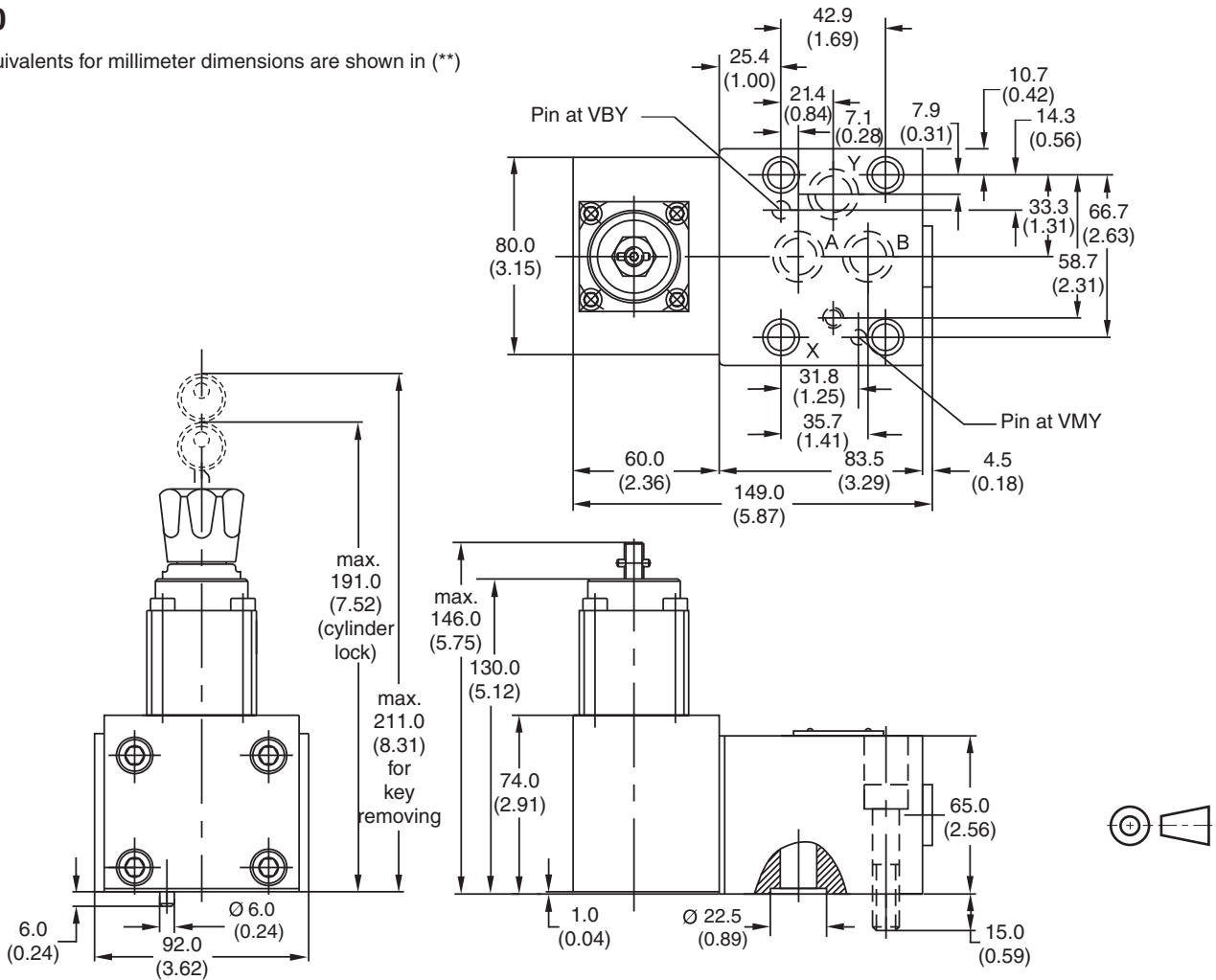

**NG10**

Inch equivalents for millimeter dimensions are shown in (\*\*)



Surface finish	Bolt kit  DIN912 12.9		 Kit FPM
	BK-M10x50-4pcs	65 Nm (47.9 lb.-ft.)	SK-VB/VM106V

**Mounting Pattern ISO 5781-06-07-0-00**

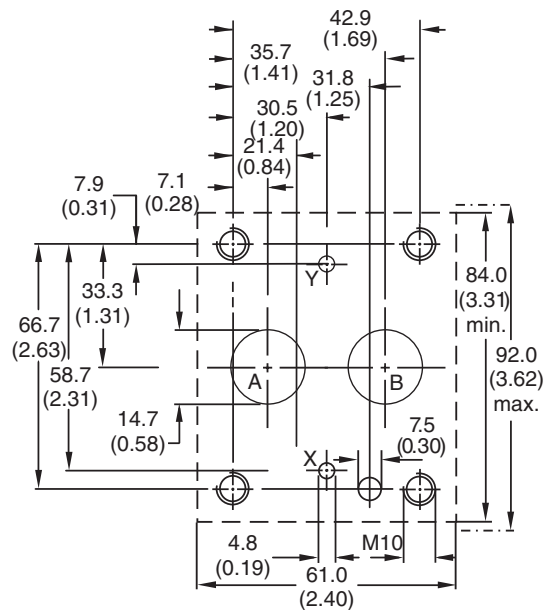

**General Description**

Series R5V pilot operated pressure relief valves have a similar design to the subplate mounted R4V series. The SAE flanges allow to mount the valves directly on the outlet flanges of pumps or inlet flanges of actuators to achieve a very compact design.

Valves with SAE flanges can also be bolted together to combine functions without the need of a manifold block.

**Operation**

The system pressure in Port A is applied to the pilot valve and to the top surface of the main poppet via an orifice in X. The hydraulically balanced main poppet is held against the seat by the main spring. In this state there is no flow through the valve. The adjusted spring force acting on the pilot cone determines the relief pressure. If the pressure in Port A exceeds the set point, the pilot cone is lifted from its seat, releasing a small pilot flow to tank. The flow through the control orifice in X creates a pressure drop which limits the pressure at the top of the main poppet to the set point. The higher system pressure in Port A now lifts the main poppet off its seat and allows flow to Port B. In the resulting float position only enough flow is passed from Port A to Port B to maintain the inlet pressure in Port A at the set point. When the pressure in Port A falls below the set point, the hydraulic balance on the main poppet is restored. The main spring then forces the main poppet to close.



R5V 2-Port

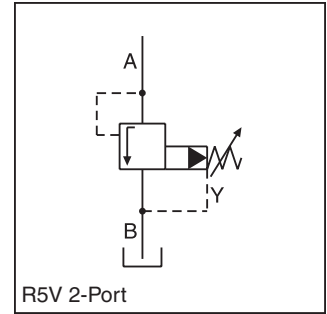

R5V 2-Port



R5V 3-Port

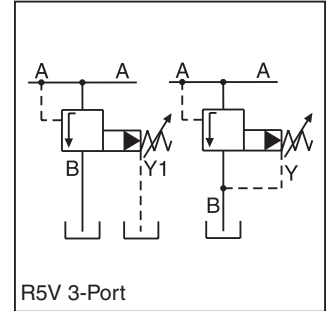

R5V 3-Port

**Features**

- Pilot operated with manual adjustment.
- R5V with 2-port body
  - 3 sizes (SAE 3/4", 1", 1-1/4")
  - SAE 61 flange
- R5V with 3-port body
  - 4 sizes (SAE 3/4", 1", 1-1/4", 1-1/2")
  - SAE 61 and SAE 62 flange
- 3 pressure stages.
- 3 adjustment modes
  - Hand knob
  - Acorn nut with lead seal
  - DIN lock
- With optional vent function.

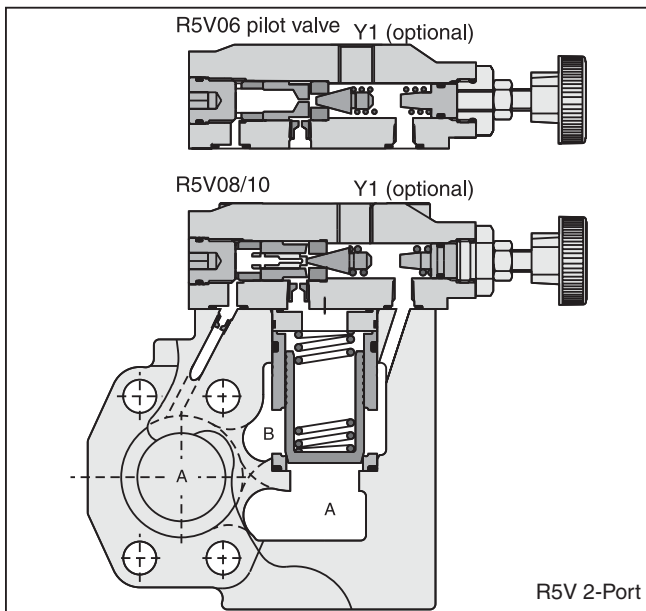

R5V 2-Port

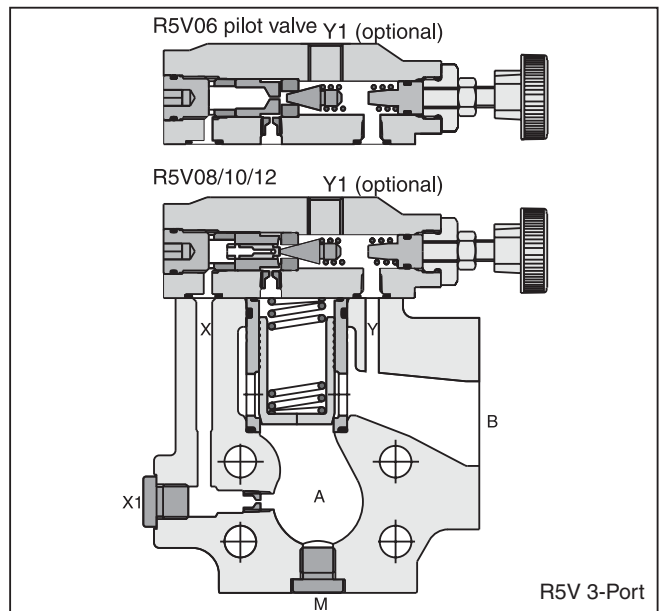

R5V 3-Port

R5V.indd, dd

**Specifications**

General							
<b>Size</b>		<b>06</b>	<b>08</b>	<b>10</b>	<b>12</b>		
<b>Mounting</b>	Flanged according to SAE 61						
<b>Mounting Position</b>	Unrestricted						
<b>Ambient Temperature Range</b>	-20°C to +50°C (-4°F to +122°F)						
Hydraulic							
<b>Maximum Operating Pressure</b>	<b>SAE 61 Ports A, B</b>	350 Bar (5075 PSI)	350 Bar (5075 PSI)	280 Bar (4060 PSI)	210 Bar (3045 PSI)		
	<b>SAE 61 Port Y1</b>	30 Bar (435 PSI)	30 Bar (435 PSI)	30 Bar (435 PSI)	30 Bar (435 PSI)		
	<b>SAE 62 Ports A, B</b>	350 Bar (5075 PSI)	350 Bar (5075 PSI)	280 Bar (4060 PSI)	210 Bar (3045 PSI)		
	<b>SAE 62 Port Y1</b>	30 Bar (435 PSI)	30 Bar (435 PSI)	30 Bar (435 PSI)	30 Bar (435 PSI)		
<b>Pressure Stages</b>	105 Bar (1523 PSI), 210 Bar (3045 PSI), 350 Bar (5075 PSI)						
<b>Nominal Flow</b>	90 LPM (23.8 GPM)	300 LPM (79.4 GPM)	600 LPM (158.7 GPM)	600 LPM (158.7 GPM)			
<b>Fluid</b>	Hydraulic oil as per DIN 51524 to 51525						
<b>Fluid Temperature</b>	-20°C to +80°C (-4°F to +176°F)						
<b>Viscosity Permitted</b>	10 to 650 cSt (mm <sup>2</sup> /s)						
<b>Viscosity Recommended</b>	30 cSt (mm <sup>2</sup> /s)						
<b>Filtration</b>	ISO Class 4406 (1999) 18/16/13 (acc. NAS 1638: 7)						
Electrical (Solenoid)							
<b>Duty Ratio</b>	100%						
<b>Solenoid Connection</b>	Connector as per EN175301-803						
<b>Protection Class</b>	IP65 in accordance with EN60529 (plugged and mounted)						
	<b>Code</b>	<b>G0R</b>	<b>G0Q</b>	<b>GAR</b>	<b>GAG</b>	<b>W30</b>	<b>W31</b>
<b>Supply Voltage</b>		12V =	24V =	98V =	205V =	110V at 50Hz/ 120V at 60Hz	220V at 50Hz/ 240V at 60Hz
<b>Tolerance Supply Voltage</b>		+5 to -10	+5 to -10	+5 to -10	+5 to -10	±5	±5
<b>Power Consumption</b>	<b>Hold</b>	31	31	31	31	64/59 [VA]	68/62 [VA]
	<b>In Rush</b>	31	31	31	31	231/240 [VA]	231/240 [VA]
<b>Response Time</b>	Energized / De-energized AC: 20/18ms, DC: 46/27 ms						
<b>Maximum Switching Frequency</b>	AC: up to 7200 switchings/hour; DC: up to 16,000 switchings/hour						
<b>Coil Insulation Class</b>	H (180°C) (356°F)						

**Performance Curves**

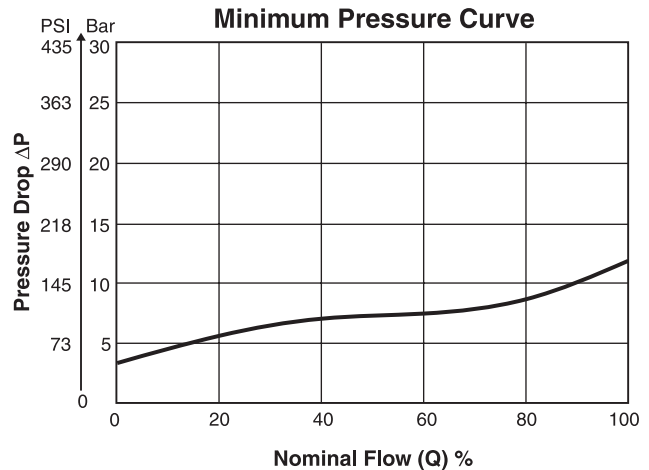
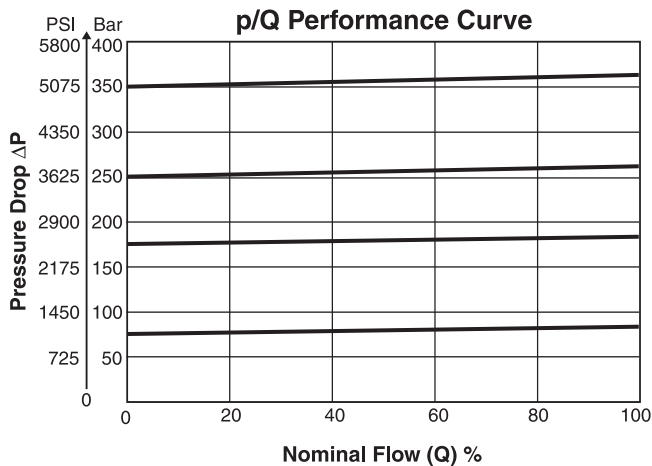

R5V.indd, dd

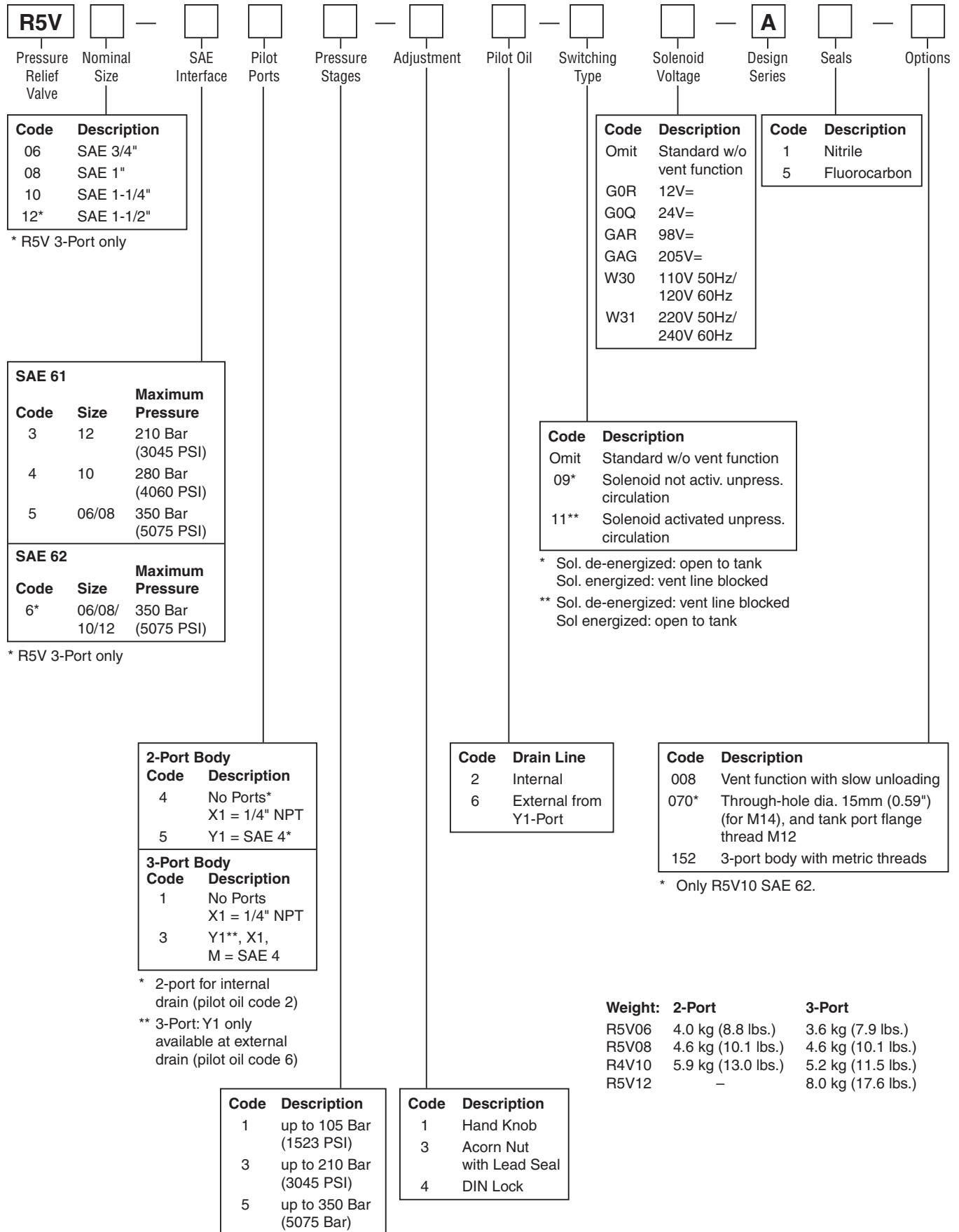

**Dimensions**

**Pilot Operated Pressure Relief Valve  
Series R5V**

Inch equivalents for millimeter dimensions are shown in (\*\*)

**2-Port**

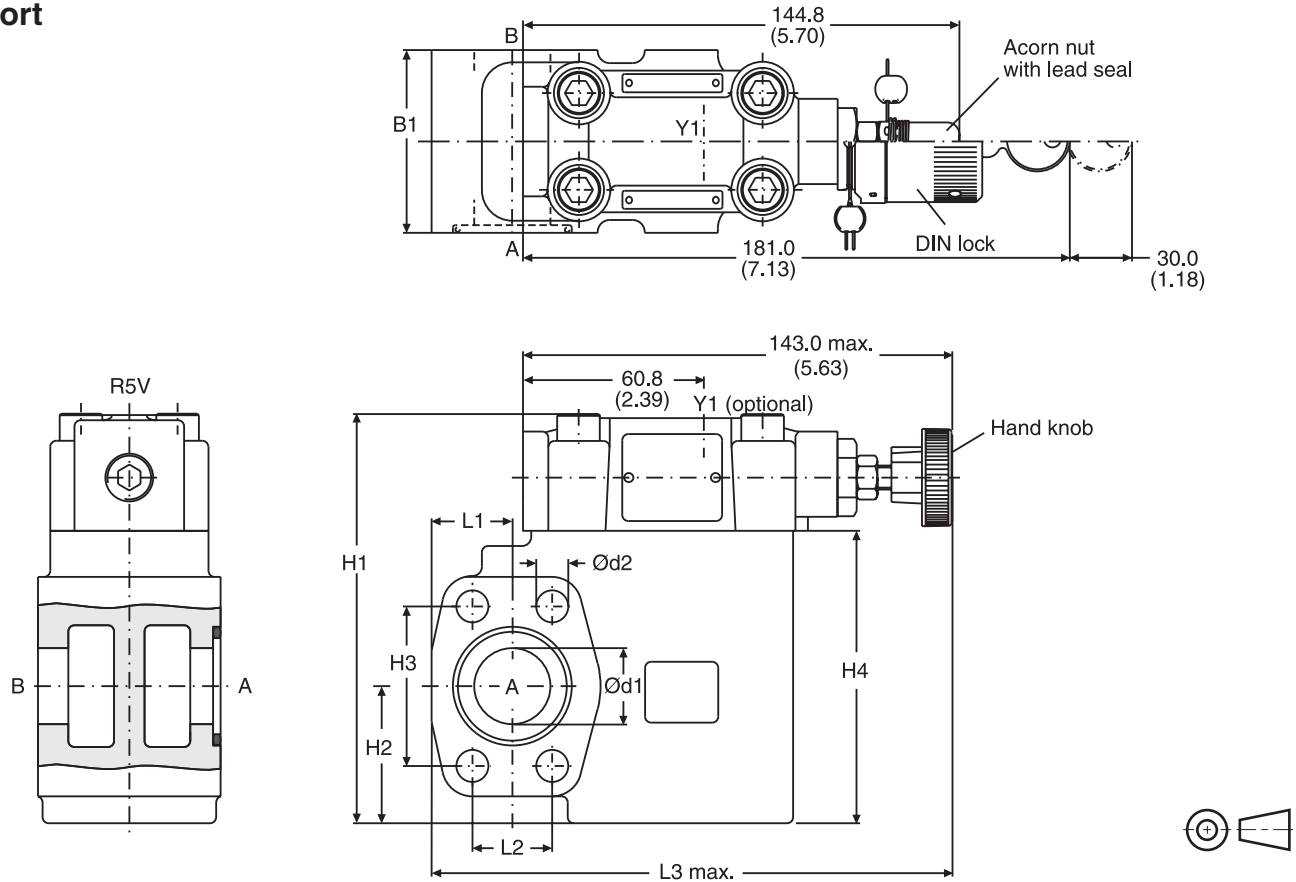

**SAE 61**

Size	B1	H1	H2	H3	H4	L1	L2	L3	d1	d2
06	60.0 (2.36)	131.6 (5.18)	37.0 (1.46)	47.6 (1.87)	90.0 (3.54)	24.6 (0.97)	22.2 (0.89)	152.0 (5.98)	19.0 (0.75)	10.5 (0.41)
08	60.0 (2.36)	137.6 (5.42)	45.0 (1.77)	52.4 (2.06)	96.0 (3.78)	26.5 (1.04)	26.2 (1.03)	171.0 (6.73)	25.0 (0.98)	10.5 (0.41)
10	75.0 (2.95)	150.6 (5.93)	48.0 (1.89)	58.7 (2.31)	109.0 (4.29)	34.0 (1.34)	30.2 (1.19)	179.0 (7.05)	32.0 (1.26)	12.5 (0.49)

Port	Function	Port Size		
		R5V06	R5V08	R5V10
A	Pressure	3/4" SAE 61	1" SAE 61	1-1/4" SAE 61
B	Tank	3/4" SAE 61	1" SAE 61	1-1/4" SAE 61
Y1	External Drain	SAE 4		

**Dimensions**

**Pilot Operated Pressure Relief Valve  
Series R5V**

Inch equivalents for millimeter dimensions are shown in (\*\*)

**3-Port**

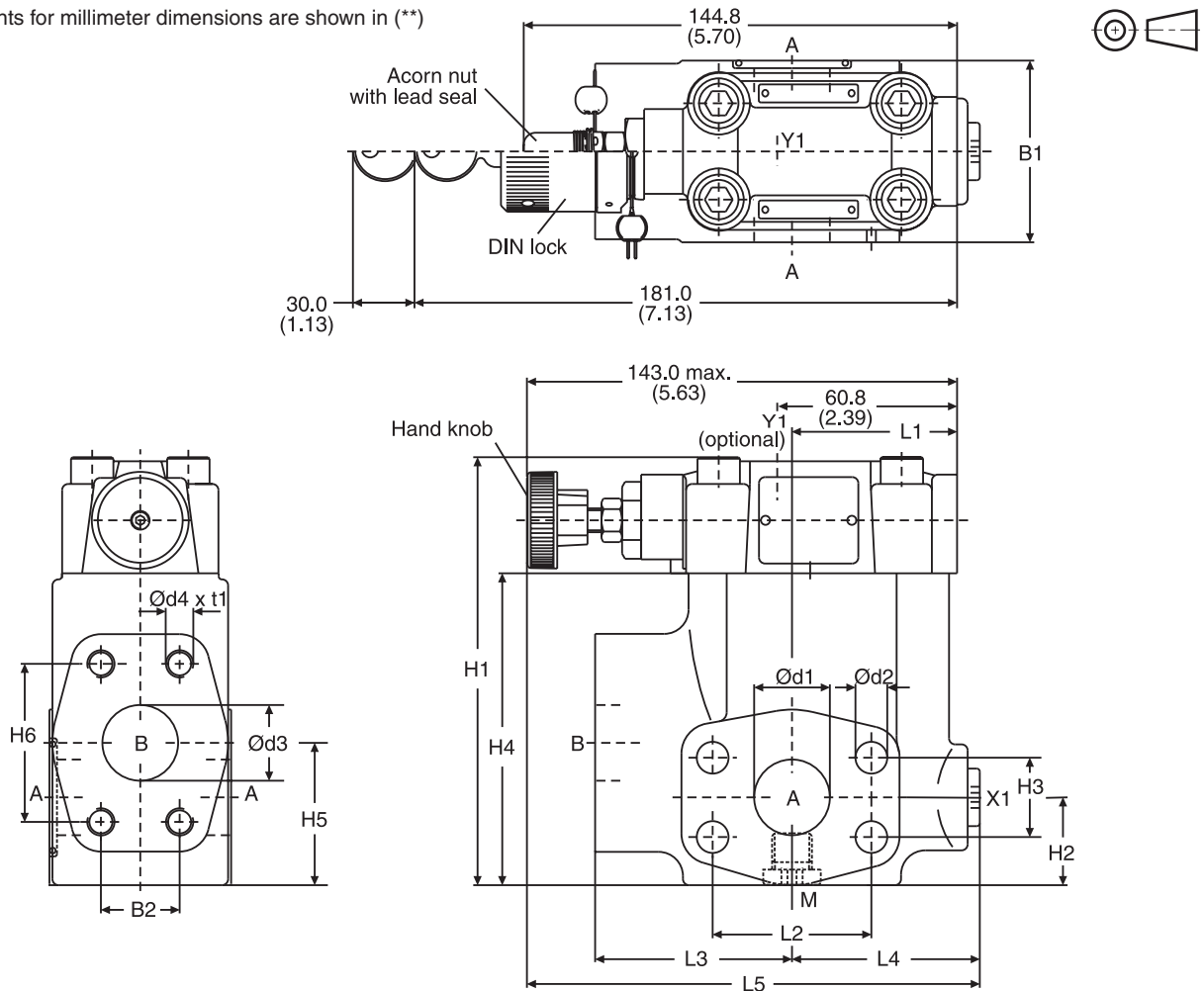

**SAE 61**

Size	B1	B2	H1	H2	H3	H4	H5	H6	L1	L2	L3	L4	L5	d1	d2	d3	d4 (option 152)	t1
06	60.0 (2.36)	22.2 (0.87)	119.0 (4.69)	28.0 (1.10)	22.2 (0.87)	81.0 (3.19)	41.6 (1.64)	47.6 (1.87)	50.3 (1.98)	47.6 (1.87)	63.0 (2.48)	56.0 (2.20)	152.0 (5.98)	19.0 (0.75)	10.5 (0.41)	19.0 (0.75)	3/8"-16 UNC (M10)	20.0 (0.79)
08	60.0 (2.36)	26.2 (1.03)	141.0 (5.55)	29.0 (1.14)	26.2 (1.03)	103.0 (4.06)	47.0 (1.85)	52.4 (2.06)	55.8 (2.20)	52.4 (2.06)	65.0 (2.56)	58.0 (2.28)	149.0 (5.87)	25.0 (0.98)	10.5 (0.41)	25.0 (0.98)	3/8"-16 UNC (M10)	23.0 (0.91)
10	75.0 (2.95)	30.2 (1.19)	151.0 (5.94)	34.5 (1.36)	30.2 (1.19)	113.0 (4.45)	64.0 (2.52)	58.7 (2.31)	57.8 (2.28)	58.7 (2.31)	61.0 (2.40)	62.0 (2.44)	150.5 (5.93)	32.0 (1.26)	12.5 (0.49)	32.0 (1.26)	7/16"-14 UNC (M12)	22.0 (0.87)
12	80.0 (3.15)	35.7 (1.41)	178.0 (7.01)	34.0 (1.34)	35.7 (1.41)	140.0 (5.51)	73.0 (2.87)	69.8 (2.75)	37.3 (1.47)	69.8 (2.75)	92.5 (3.64)	55.2 (2.17)	171.2 (6.74)	38.0 (1.50)	13.5 (0.53)	38.0 (1.50)	1/2"-13 UNC (M12)	27.0 (1.06)

**SAE 62**

Size	B1	B2	H1	H2	H3	H4	H5	H6	L1	L2	L3	L4	L5	d1	d2	d3	d4 (option 152)	t1
06	60.0 (2.36)	23.8 (0.94)	119.0 (4.69)	28.0 (1.10)	23.8 (0.94)	81.0 (3.19)	41.6 (1.64)	50.8 (2.00)	50.3 (1.98)	50.8 (2.00)	63.0 (2.48)	56.0 (2.20)	152.0 (5.98)	19.0 (0.75)	10.5 (0.41)	19.0 (0.75)	3/8"-16 UNF (M10)	20.0 (0.79)
08	60.0 (2.36)	27.8 (1.09)	141.0 (5.55)	29.0 (1.14)	27.8 (1.09)	103.0 (4.06)	47.0 (1.85)	57.2 (2.25)	55.8 (2.20)	57.2 (2.25)	65.0 (2.56)	58.0 (2.28)	149.0 (5.87)	25.0 (0.98)	12.5 (0.49)	25.0 (0.98)	7/16"-14 UNC (M12)	22.0 (0.87)
10	75.0 (2.95)	31.8 (1.25)	151.0 (5.94)	34.5 (1.36)	31.8 (1.25)	113.0 (4.45)	64.0 (2.52)	66.7 (2.63)	57.8 (2.28)	66.7 (2.63)	61.0 (2.40)	62.0 (2.44)	150.5 (5.93)	32.0 (1.26)	13.5 (0.53)	32.0 (1.26)	1/2"-13 UNC (M12)	24.0 (0.94)
12	80.0 (3.15)	36.5 (1.44)	178.0 (7.01)	34.0 (1.34)	36.5 (1.44)	140.0 (5.51)	73.0 (2.87)	79.4 (3.13)	37.3 (1.47)	79.4 (3.13)	92.5 (3.64)	55.2 (2.17)	171.2 (6.74)	38.0 (1.50)	17.0 (0.67)	38.0 (1.50)	5/8"-11 UNC (M16)	33.0 (1.30)

Port	Function	Port size			
		R5V06	R5V08	R5V10	R5V12
A (2)	Pressure	3/4" SAE 61/62	1" SAE 61/62	1-1/4" SAE 61/62	1-1/2" SAE 61/62
B	Tank	3/4" SAE 61/62	1" SAE 61/62	1-1/4" SAE 61/62	1-1/2" SAE 61/62
X1	External pilot port *	SAE 4			
Y1	External drain	SAE 4			
M	Pressure gauge	SAE 4			

R5V.indd, dd

\* closed when supplied.



Inch equivalents for millimeter dimensions are shown in (\*\*)

**with Vent Function**

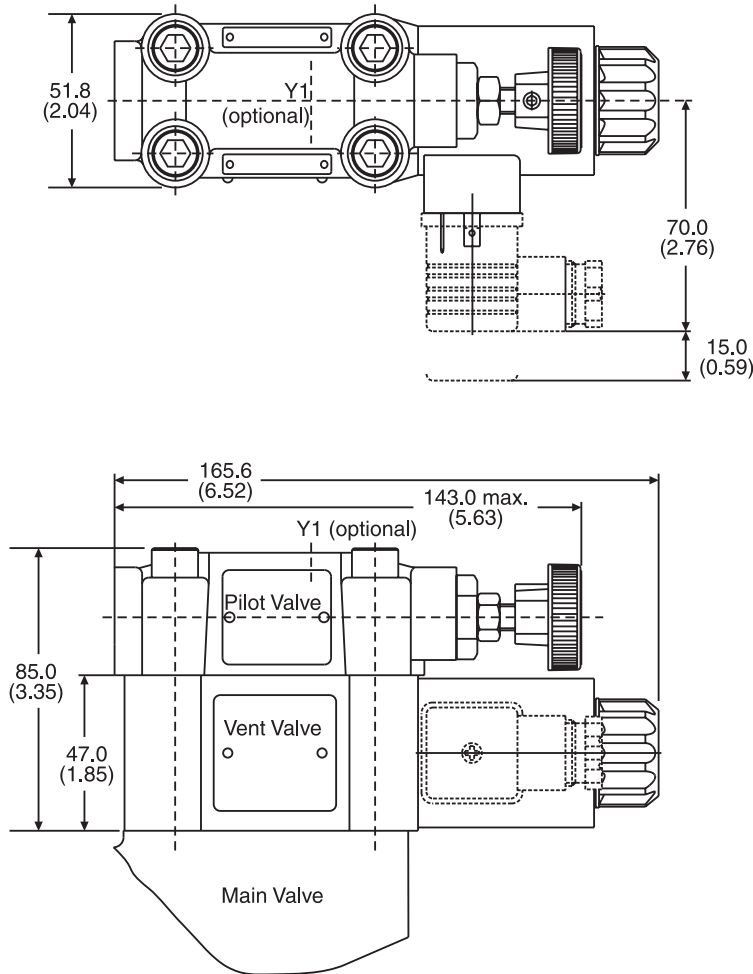

Code	R5V 2-Port		R5V 3-Port	
	Internal Drain	External Drain	Internal Drain	External Drain
11				
09				

### General Description

Series R5R pilot operated pressure reducing valves have a similar design as the subplate mounted R4R series. The SAE flanges allow to mount the valves directly on the inlet flanges of actuators to achieve a very compact design.

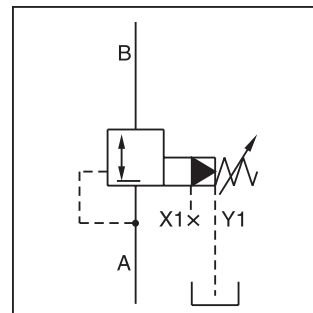
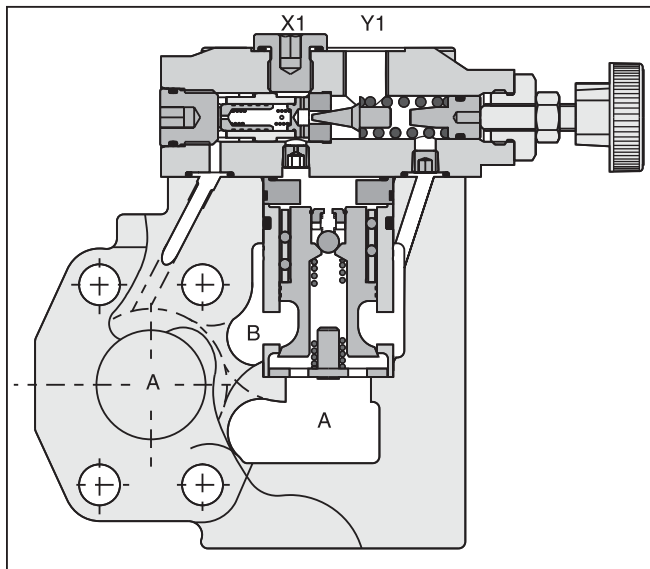

### Features

- Pilot operated with manual adjustment.
- Normally closed to avoid unintended motion.
- 2-port body with SAE61 flange.
- 3 sizes (SAE 3/4", 1", 1-1/4").
- 3 pressure stages.
- 3 adjustment modes
  - Hand knob
  - Acorn nut with lead seal
  - DIN lock
- With optional vent function.

### Specifications

General						
Size	06		08		10	
Mounting	Flanged according to SAE 61					
Mounting Position	Unrestricted					
Ambient Temperature Range	-20°C to +50°C (-4°F to +122°F)					
Hydraulic						
Max. Operating Pressure	Ports A,B, X1	350 Bar (5075 PSI)	350 Bar (5075 PSI)	280 Bar (4060 PSI)		
	Port Y1	30 Bar (435 PSI)	30 Bar (435 PSI)	30 Bar (435 PSI)		
Pressure Stages	105 Bar (1523 PSI), 210 Bar (3045 PSI), 350 Bar (5075 PSI)					
Nominal Flow	90 LPM (23.8 GPM)	300 LPM (79.4 GPM)	600 LPM (158.7 GPM)			
Fluid	Hydraulic oil as per DIN 51524 ... 51525					
Fluid Temperature	-20°C to +80°C (-4°F to +176°F)					
Viscosity Permitted	10 to 650 cSt (mm <sup>2</sup> /s)					
Viscosity Recommended	30 cSt (mm <sup>2</sup> /s)					
Filtration	ISO Class 4406 (1999) 18/16/13 (acc. NAS 1638: 7)					
Electrical (Solenoid)						
Duty Ratio	100%					
Solenoid Connection	Connector as per EN175301-803					
Protection Class	IP65 in accordance with EN60529 (plugged and mounted)					
Supply Voltage	<b>G0R</b>	<b>G0Q</b>	<b>GAR</b>	<b>GAG</b>	<b>W30</b>	<b>W31</b>
	12V =	24V =	98V =	205V =	110V at 50Hz	220V at 50Hz
	+5 to -10	+5 to -10	+5 to -10	+5 to -10	120V at 60Hz	240V at 60Hz
	31 31	31 31	31 31	31 31	±5 64/59 [VA] 231/240 [VA]	±5 68/62 [VA] 231/240 [VA]
Response Time	Energized / De-energized AC: 20/18ms, DC: 46/27 ms					
Max. Switching Frequency	AC: up to 7200, DC: 70 to 16,000 switchings/hour					
Coil Insulation Class	H (180°C) (356°F)					

R5R.indd, dd



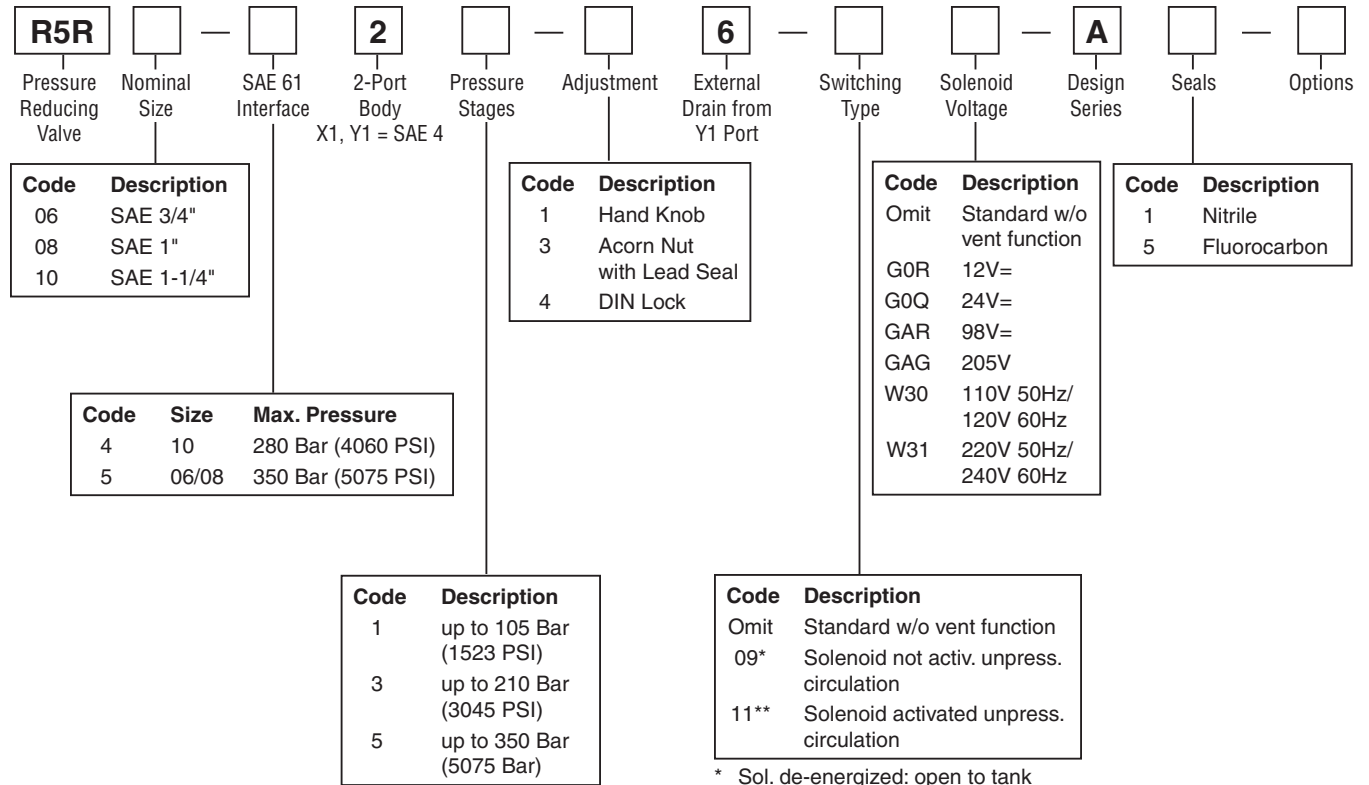

\* Sol. de-energized: open to tank  
 Sol. energized: vent line blocked

\*\* Sol. de-energized: vent line blocked  
 Sol energized: open to tank

Further options on request.

**Weight:**

R5R06 4.0 kg (8.8 lbs.)  
 R5R08 4.6 kg (10.1 lbs.)  
 R5R10 5.9 kg (13.0 lbs.)

**R5R06\***

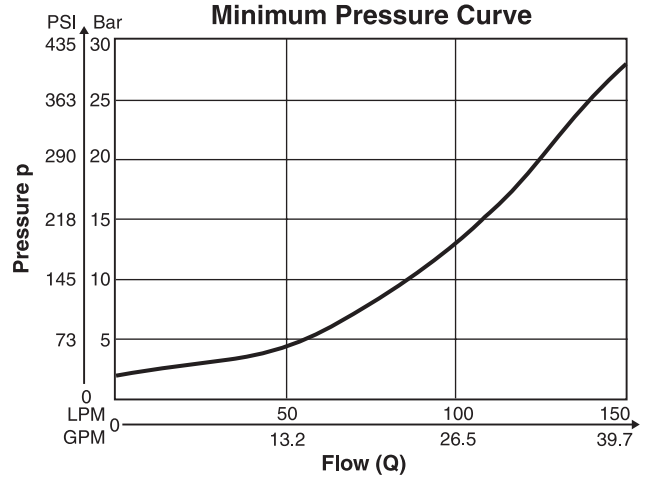
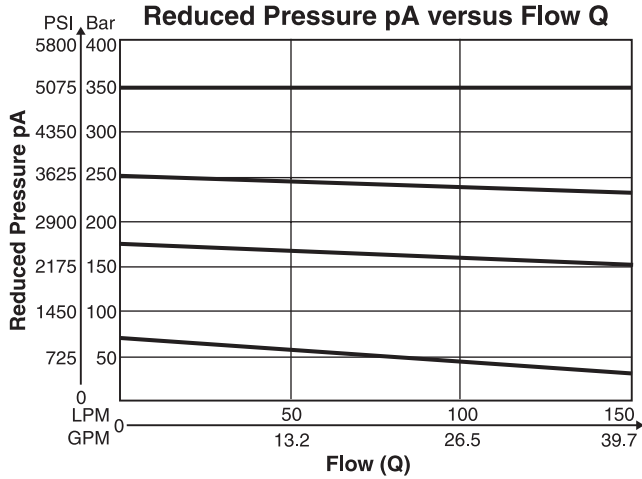

**R5R08\***

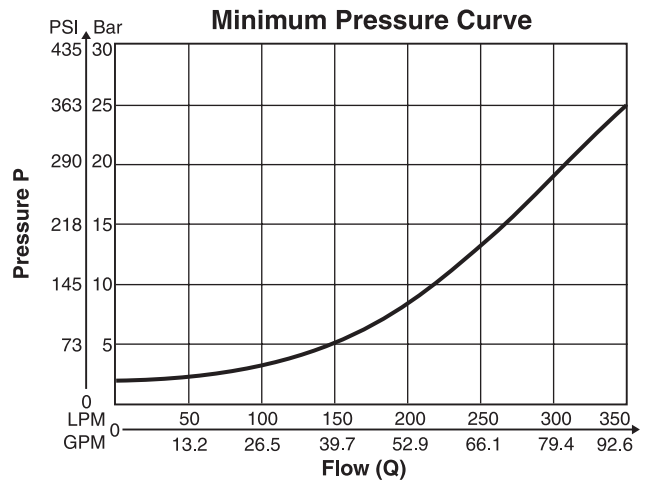
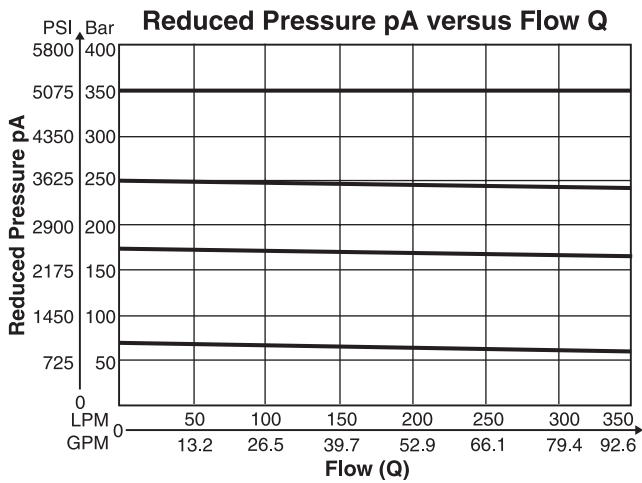

**R5R10\***

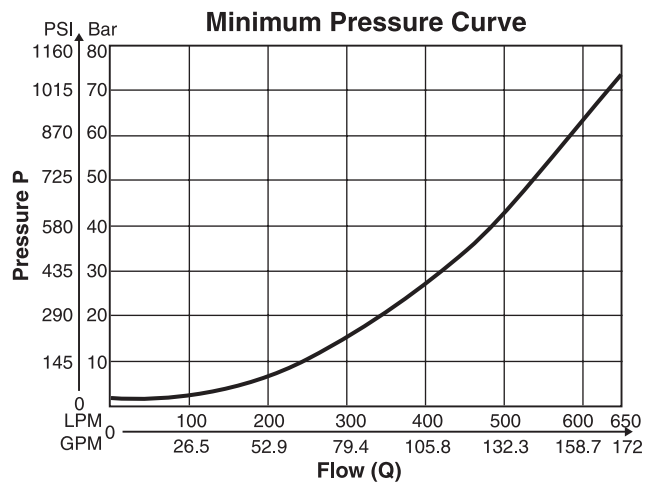
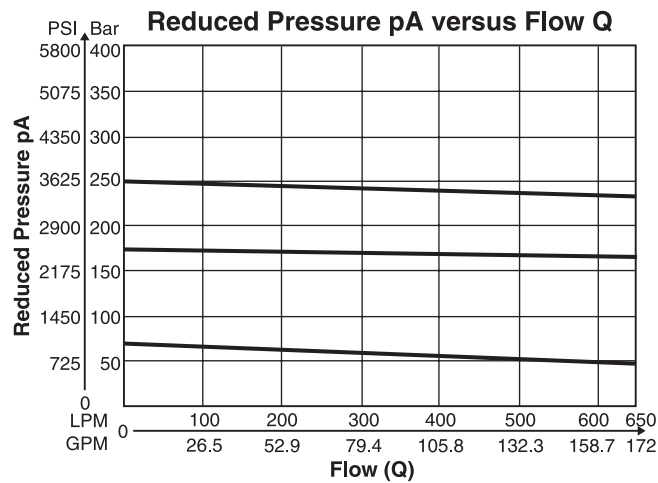

\*Measured at 350 Bar (5075 PSI) primary pressure pB.

**Dimensions**

**Pilot Operated Pressure Relief Valve  
Series R5R**

Inch equivalents for millimeter dimensions are shown in (\*\*)

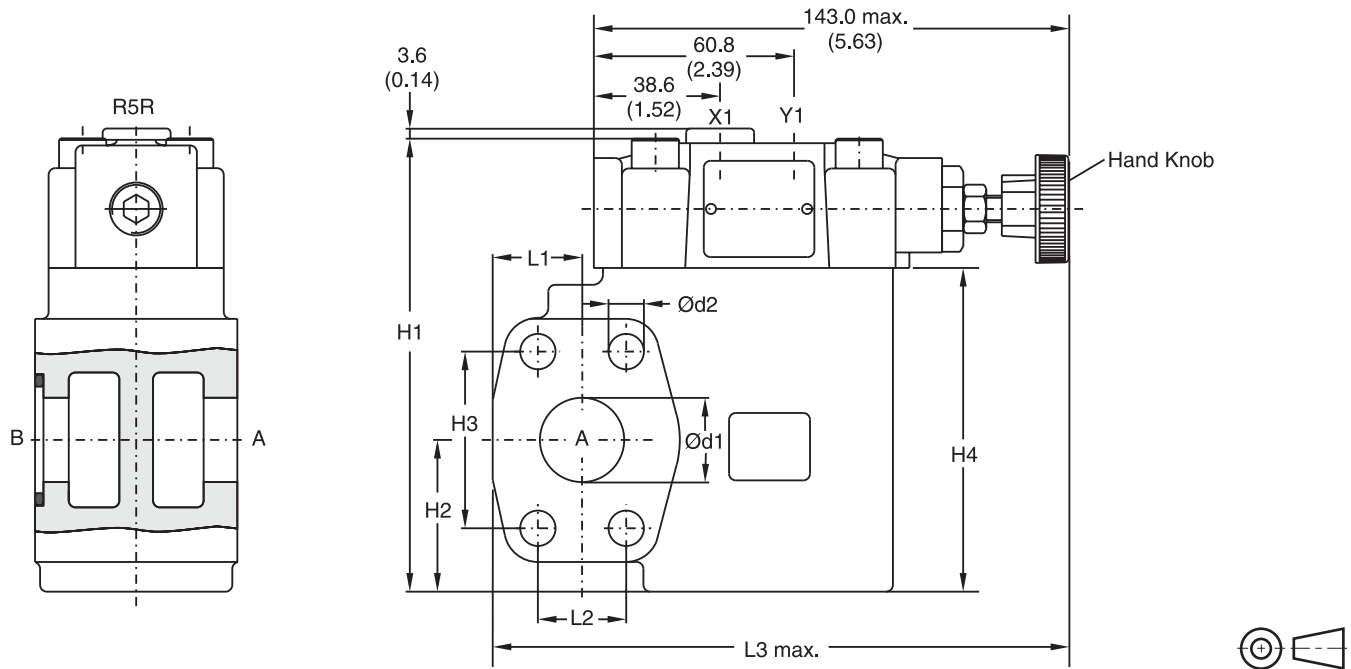
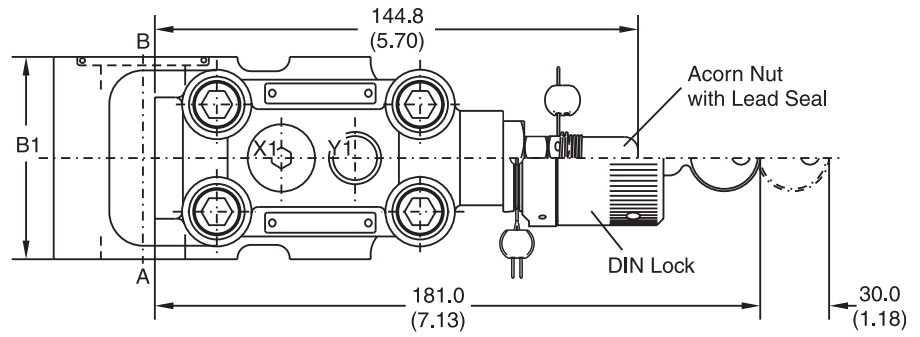

Size	B1	H1	H2	H3	H4	L1	L2	L3	d1	d2
06	60.0 (2.36)	131.6 (5.18)	37.0 (1.46)	47.6 (1.87)	90.0 (3.54)	24.6 (0.97)	22.2 (0.87)	152.0 (5.98)	19.0 (0.75)	10.5 (0.41)
08	60.0 (2.36)	137.6 (5.42)	45.0 (1.77)	52.4 (2.06)	96.0 (3.78)	26.5 (1.04)	26.2 (1.03)	171.0 (6.73)	25.0 (0.98)	10.5 (0.41)
10	75.0 (2.95)	150.6 (5.93)	48.0 (1.89)	58.7 (2.31)	109.0 (4.29)	34.0 (1.34)	30.2 (1.19)	179.0 (7.05)	32.0 (1.26)	12.5 (0.49)

Port	Function	Port Size		
		R5R06	R5R08	R5R10
B	Inlet Pressure	3/4" SAE 61	1" SAE 61	1-1/4" SAE 61
A	Reduced Outlet Pressure	3/4" SAE 61	1" SAE 61	1-1/4" SAE 61
Y1	External Drain	SAE 4		
X1	Pressure Gauge	SAE 4		

**R5R with Vent Function**

Inch equivalents for millimeter dimensions are shown in (\*\*)

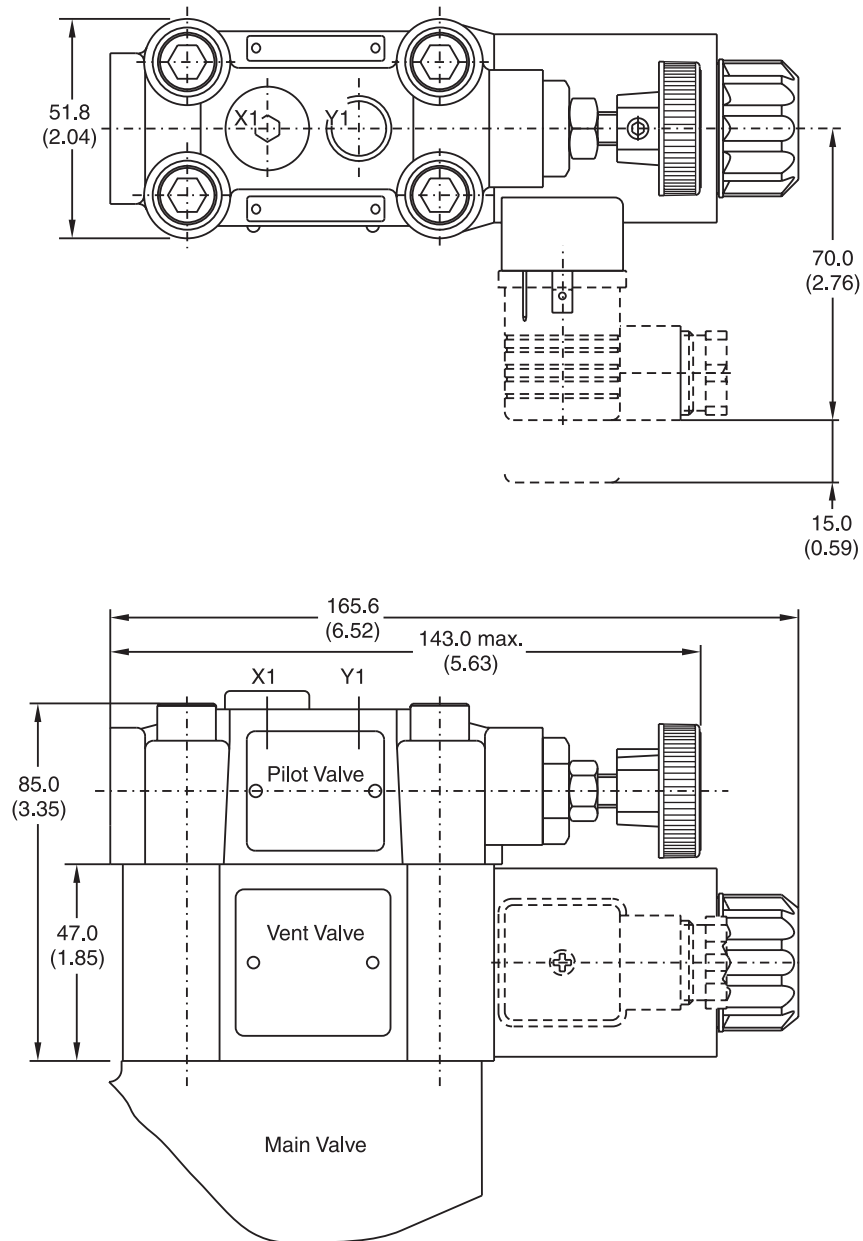

**External Drain**

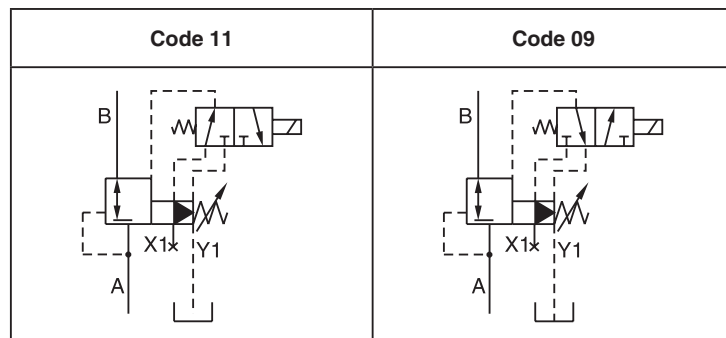

R5R.indd, dd

**General Description**

Series R5U pilot operated pressure unloading valves have a similar design to the subplate mounted R4U series. The SAE flanges allow to mount the valve directly on the outlet flanges of pumps.

A typical application is the unloading of a pump in an accumulator circuit. The combination of an R5U, C5V and R5V on a double pump generates a high pressure / low pressure pump system without the need of a manifold block or piping between the valves.

**Features**

- Pilot operated unloading valve.
- 3-port body with SAE 61 flange.
- 4 sizes (SAE 3/4", 1", 1 1/4", 1 1/2").
- 3 pressure stages.
- 3 adjustment modes
  - Hand knob
  - Acorn nut with lead seal
  - DIN lock
- With optional vent function.

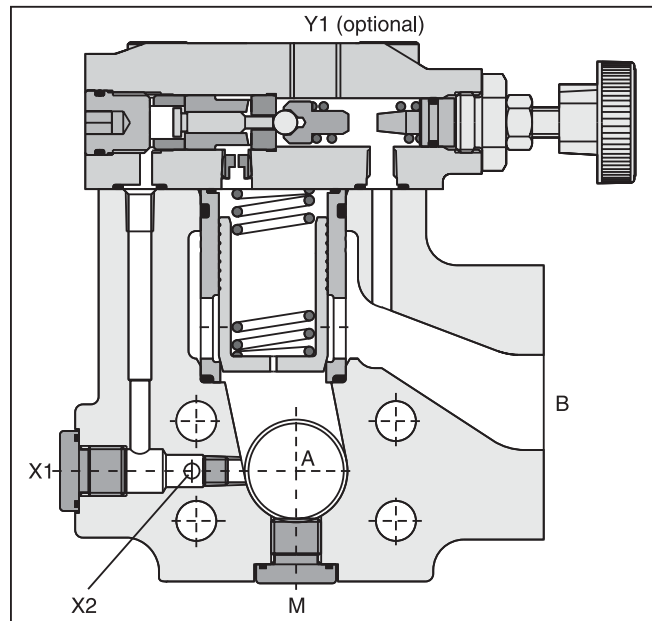
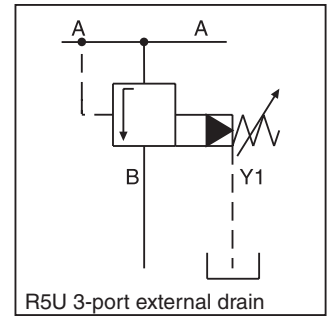
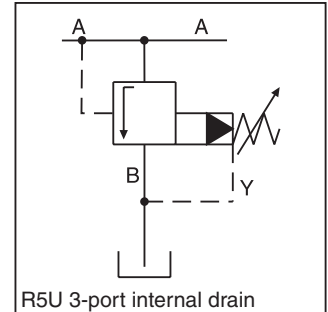

**High Pressure / Low Pressure System**

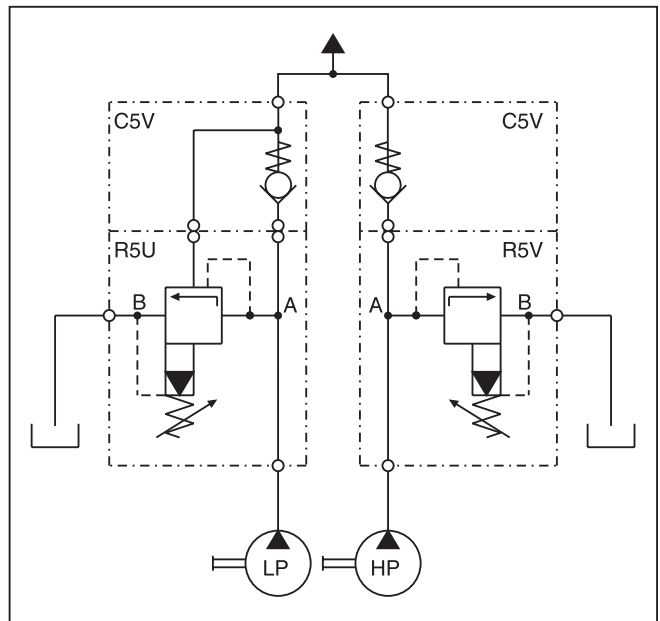

## Specifications

General									
Size	06		08		10		12		
<b>Mounting</b>	Flanged according to SAE 61								
<b>Mounting Position</b>	Unrestricted								
<b>Ambient Temperature</b>	-20°C to +50°C (-4°F to +122°F)								
Hydraulic									
<b>Maximum Operating Pressure</b>	<b>Ports A,B, X</b>	350 Bar (5075 PSI)		350 Bar (5075 PSI)		280 Bar (4060 PSI)		210 Bar (3045 PSI)	
	<b>Ports Y, Y1</b>	30 Bar (435 PSI)		30 Bar (435 PSI)		30 Bar (435 PSI)		30 Bar (435 PSI)	
<b>Pressure Stages</b>	105 Bar (1523 PSI), 210 Bar (3045 PSI), 350 Bar (5075 PSI)								
<b>Nominal Flow</b>	90 LPM (23.8 GPM)		300 LPM (79.4 GPM)		600 LPM (158.7 GPM)		600 LPM (158.7 GPM)		
<b>Fluid</b>	Hydraulic oil as per DIN 51524 ... 51525								
<b>Fluid Temperature</b>	-20°C to +80°C (-4°F to +176°F)								
<b>Viscosity Permitted</b>	10 to 650 cSt (mm <sup>2</sup> /s)								
<b>Viscosity Recommended</b>	30 cSt (mm <sup>2</sup> /s)								
<b>Filtration</b>	ISO Class 4406 (1999) 18/16/13 (acc. NAS 1638: 7)								
Electrical									
<b>Duty Ratio</b>	100%								
<b>Solenoid Connection</b>	Connector as per EN175301-803								
<b>Protection Class</b>	IP65 in accordance with EN60529 (plugged and mounted)								
<b>Supply Voltage</b>	<b>G0R</b>	<b>G0Q</b>	<b>GAR</b>	<b>GAG</b>	<b>W30</b>	<b>W31</b>			
	12V = +5 to -10 31 31	24V = +5 to -10 31 31	98V = +5 to -10 31 31	205V = +5 to -10 31 31	110V at 50Hz 120V at 60Hz ±5 64/59 [VA] 231/240 [VA]	220V at 50Hz 240V at 60Hz ±5 68/62 [VA] 231/240 [VA]			
<b>Response Time</b>	Energized / De-energized AC: 20/18ms, DC: 46/27 ms								
<b>Maximum Switching Frequency</b>	AC: up to 7200 switchings/hour DC: 70 to 16,000 switchings/hour								
<b>Coil Insulation Class</b>	H (180°C) (356°F)								

**Ordering Information**

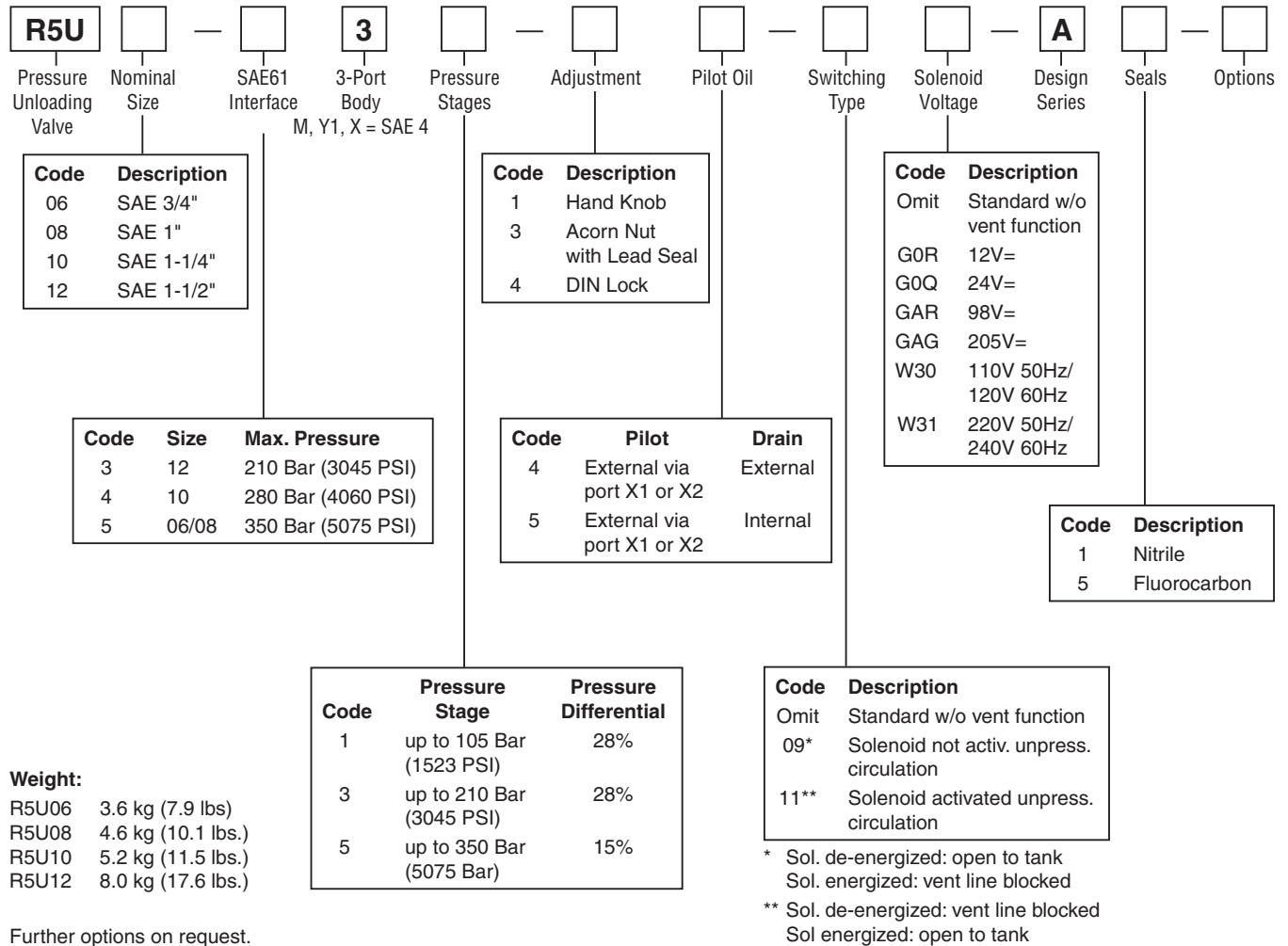

**Performance Curves**

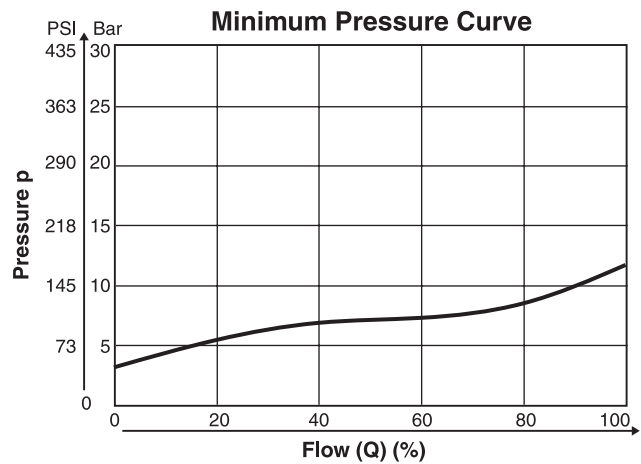
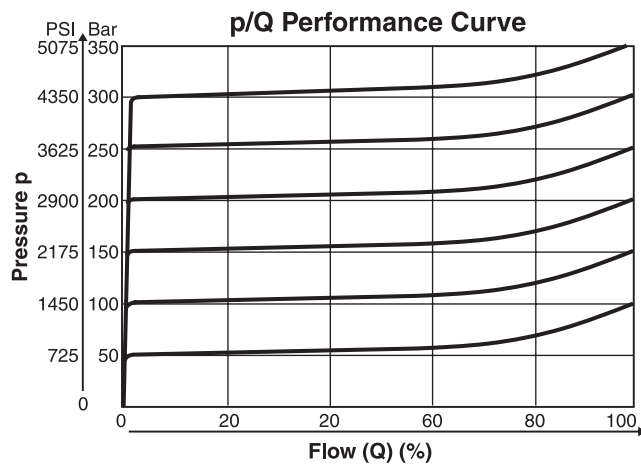

The performance curves are measured with external drain.  
 For internal drain the tank pressure has to be added to curve.

R5U.indd, dd

**Dimensions**

**Pilot Operated Unloading Valve  
Series R5U**

Inch equivalents for millimeter dimensions are shown in (\*\*)

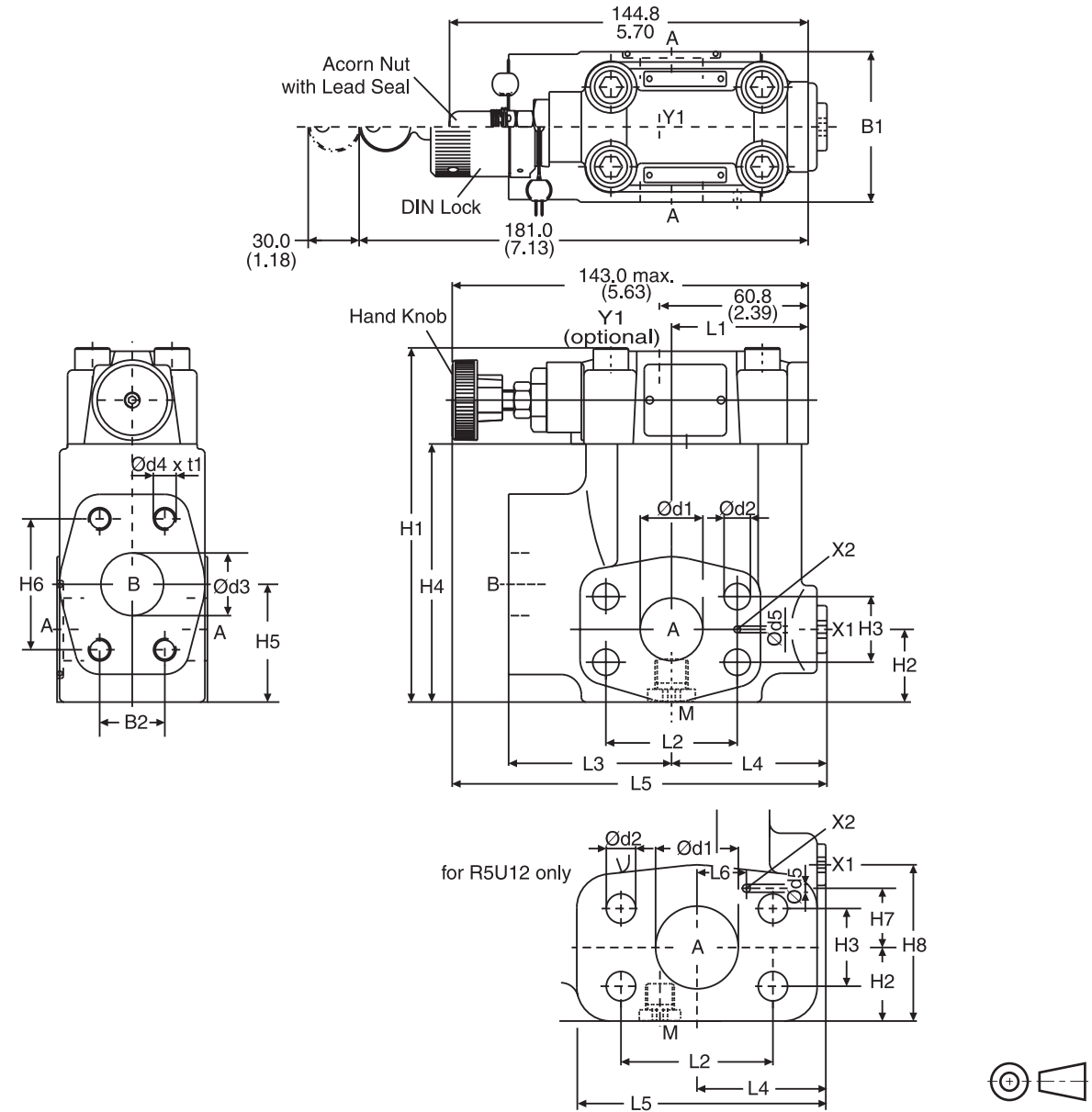

Size	B1	B2	H1	H2	H3	H4	H5	H6	L1	L2	L3	L4	L5	d1	d2	d3	d4	t1	d5	L6	H7	H8
06	60.0 (2.36)	22.2 (0.87)	119.0 (4.69)	28.0 (1.10)	22.2 (0.87)	81.0 (3.19)	41.6 (1.64)	47.6 (1.87)	50.0 (1.98)	47.6 (1.87)	63.0 (2.48)	56.0 (2.20)	152.0 (5.98)	19.0 (0.75)	10.5 (0.41)	19.0 (0.75)	3/8"-16 UNC	20.0 (0.79)	3.0 (0.12)	-	-	-
08	60.0 (2.36)	26.2 (1.03)	141.0 (5.55)	29.0 (1.14)	26.2 (1.03)	103.0 (4.06)	47.0 (1.85)	52.4 (2.06)	55.8 (2.20)	52.4 (2.06)	65.0 (2.56)	58.0 (2.28)	149.0 (5.87)	25.0 (0.98)	10.5 (0.41)	25.0 (0.98)	3/8"-16 UNC	23.0 (0.91)	3.0 (0.12)	-	-	-
10	75.0 (2.95)	30.2 (1.19)	151.0 (5.94)	34.5 (1.36)	30.2 (1.19)	113.0 (4.45)	64.0 (2.52)	58.7 (2.31)	57.8 (2.28)	58.7 (2.31)	61.0 (2.40)	62.0 (2.44)	150.5 (5.93)	32.0 (1.26)	12.5 (0.49)	32.0 (1.26)	7/16"-14 UNC	22.0 (0.87)	3.0 (0.12)	-	-	-
12	80.0 (3.15)	35.7 (1.41)	178.0 (7.01)	34.0 (1.34)	35.7 (1.41)	140.0 (5.51)	73.0 (2.87)	69.8 (2.75)	37.3 (1.47)	69.8 (2.75)	92.5 (3.64)	55.2 (2.17)	171.2 (6.74)	38.0 (1.50)	13.5 (0.53)	38.0 (1.50)	1/2"-13 UNC	27.0 (1.06)	3.0 (0.12)	34.9 (1.37)	27.2 (1.07)	73.0 (2.87)

Port	Function	Port Size			
		R5U06	R5U08	R5U10	R5U12
A (2)	Pressure	3/4" SAE 61	1" SAE 61	1-1/4" SAE 61	1-1/2" SAE 61
B	Tank	3/4" SAE 61	1" SAE 61	1-1/4" SAE 61	1-1/2" SAE 61
X1	External Pilot Port*	SAE 4			
Y1	External Drain	SAE 4			
M	Pressure Gauge	SAE 4			

\* closed when supplied.

R5U.indd, dd







**General Description**

Series R5S pilot operated sequence valves have a similar design to the subplate mounted R4S series. The SAE flanges allow to mount the valve directly on the inlet flanges of actuators or outlet flanges of pumps to achieve a very compact design.

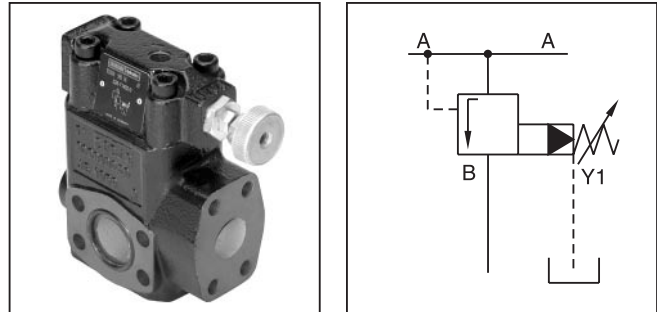

**Features**

- Pilot operated with manual adjustment.
- 3-port body with SAE61 flange.
- 3 sizes (SAE 3/4", 1", 1-1/4").
- 3 pressure stages.
- 2 adjustment modes
  - Hand knob
  - Acorn nut with lead seal

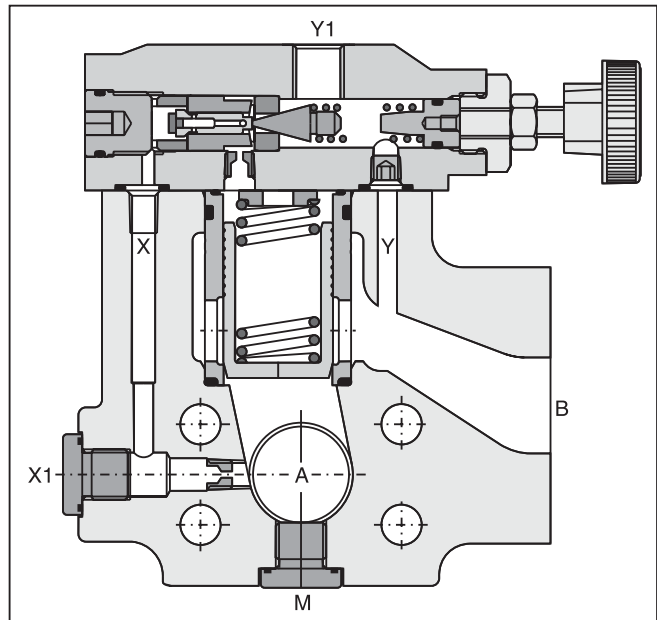

**Specifications**

General				
Size		06	08	10
Mounting		Flanged according to SAE 61		
Mounting Position		Unrestricted		
Ambient Temperature Range		-20°C to +50°C (-4°F to +122°F)		
Hydraulic				
Max. Operating Pressure	Ports A,B	350 Bar (5075 PSI)	350 Bar (5075 PSI)	280 Bar (4060 PSI)
	Ports Y, Y1	30 Bar (435 PSI)	30 Bar (435 PSI)	30 Bar (435 PSI)
Pressure Stages		105 Bar (1523 PSI), 210 Bar (3045 PSI), 350 Bar (5075 PSI)		
Nominal Flow		90 LPM (23.3 GPM)	300 LPM (79.4 GPM)	600 LPM (158.7 GPM)
Fluid		Hydraulic oil as per DIN 51524 ... 51525		
Fluid Temperature		-20°C to 80°C (-4°F to 176°F)		
Viscosity Permitted		10 to 650 cSt (mm <sup>2</sup> /s)		
Viscosity Recommended		30 cSt (mm <sup>2</sup> /s)		
Filtration		ISO Class 4406 (1999) 18/16/13 (acc. NAS 1638: 7)		

**Ordering Information**

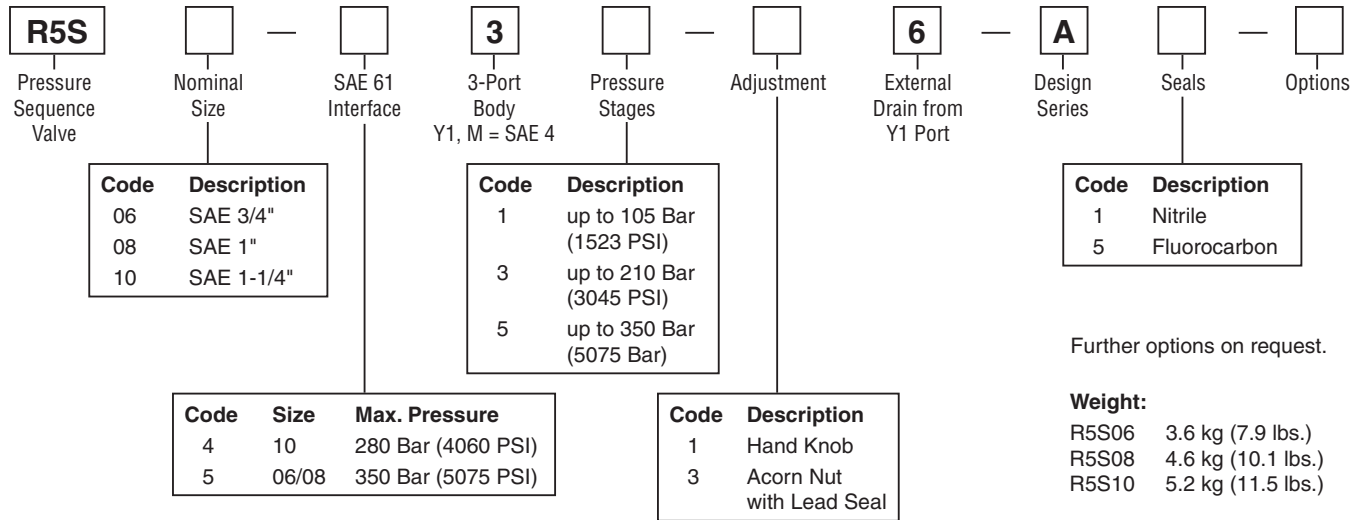

**Performance Curve**

**Typical Pressure Characteristics at Closing Point**

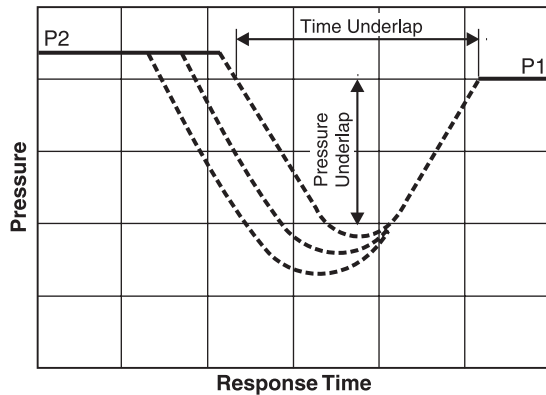

P1 = Setting Pressure  
 P2 = Operating Pressure

Time and pressure underlap depend on the characteristics of the specific system.

**Dimensions**

**Pilot Operated Sequence Valve  
Series R5S**

Inch equivalents for millimeter dimensions are shown in (\*\*)

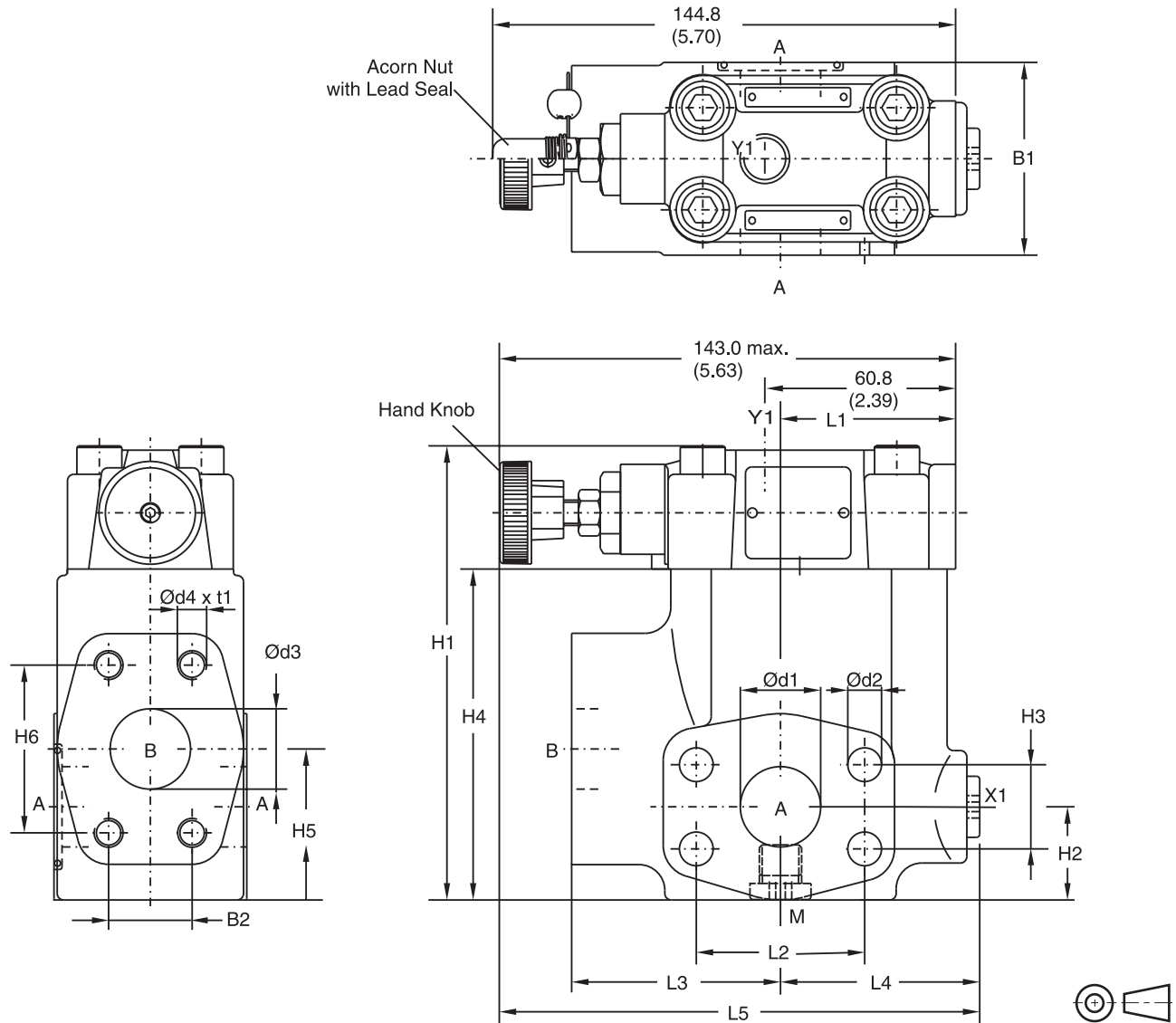

**SAE 61**

Size	B1	B2	H1	H2	H3	H4	H5	H6	L1	L2	L3	L4	L5	d1	d2	d3	d4 (option 152)	t1
06	60.0 (2.36)	22.2 (0.87)	119.0 (4.69)	28.0 (1.10)	22.2 (0.87)	81.0 (3.19)	41.6 (1.64)	47.6 (1.87)	50.3 (1.98)	47.6 (1.87)	63.0 (2.48)	56.0 (2.20)	152.0 (5.98)	19.0 (0.75)	10.5 (0.41)	19.0 (0.75)	3/8"-16 UNC (M10)	20.0 (0.79)
08	60.0 (2.36)	26.2 (1.03)	141.0 (5.55)	29.0 (1.14)	26.2 (1.03)	103.0 (4.06)	47.0 (1.85)	52.4 (2.06)	55.8 (2.20)	52.4 (2.06)	65.0 (2.56)	58.0 (2.28)	149.0 (5.87)	25.0 (0.93)	10.5 (0.41)	25.0 (0.98)	3/8"-16 UNC (M10)	23.0 (0.91)
10	75.0 (2.95)	30.2 (1.19)	151.0 (5.94)	34.5 (1.36)	30.2 (1.19)	113.0 (4.45)	64.0 (1.52)	58.7 (2.31)	57.8 (2.28)	58.7 (2.31)	61.0 (2.40)	62.0 (2.44)	150.5 (5.93)	32.0 (1.26)	12.5 (0.49)	32.0 (1.26)	7/16"-14 UNC (M12)	22.0 (0.87)

Port	Function	Port Size		
		R5S06	R5S08	R5S10
A (2)	Pressure	3/4" SAE 61	1" SAE 61	1-1/4" SAE 61
B	Secondary Port	3/4" SAE 61	1" SAE 61	1-1/4" SAE 61
X1	External Pilot Port*	SAE 4		
Y1	External Drain	SAE 4		
M	Pressure Gauge	SAE 4		

\* closed when supplied.

R5S.indd, dd



### General Description

Series R5A direct operated 2-way pressure compensators can be combined with any type of fixed or adjustable flow resistor (throttle) to provide a load compensated flow. The combination with the proportional throttle valve F5C serves as a compact 2-way flow control unit in SAE flange design. The R5A is typically used as meter-out compensator behind the flow resistor.

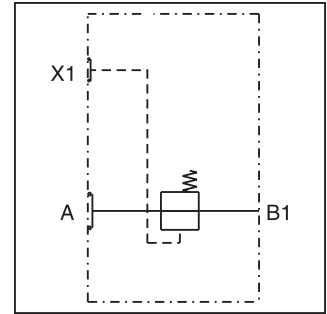

### Features

- Seated type 2 way pressure compensator.
- SAE 61 flange.
- 8.4 bar (121.8 PSI) control pressure.
- 3 sizes, SAE 3/4", 1", 1 1/4".
- Load compensated flow in combination with F5C.

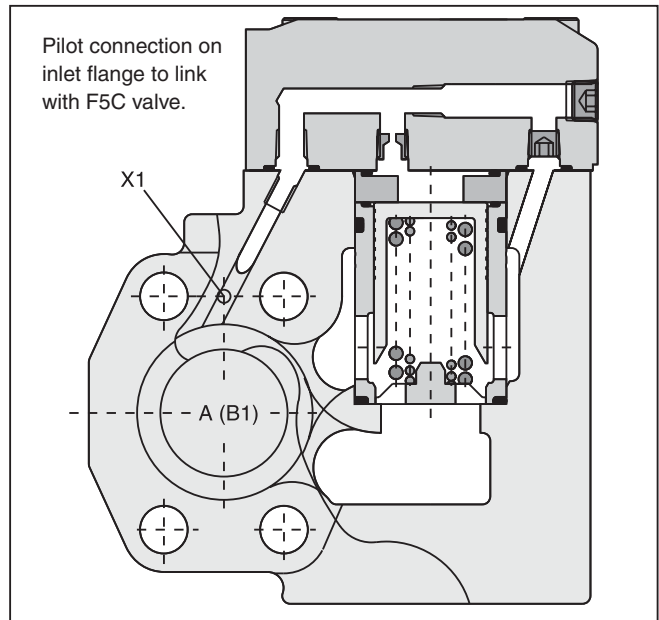

### Specifications

General			
Size	06	08	10
Suplute Mounting	Flanged according to SAE 61		
Mounting Position	Unrestricted		
Ambient Temperature Range	-20°C to +50°C (-4°F to +122°F)		
Hydraulic			
Maximum Operating Pressure	350 Bar (5075 PSI)	350 Bar (5075 PSI)	280 Bar (4060 PSI)
Control Pressure	8.4 Bar (121 PSI)		
Nominal Flow	90 LPM (23.8 GPM)	300 LPM (79.4 GPM)	600 LPM (158.7 GPM)
Fluid	Hydraulic oil as per DIN 51524 ... 51525		
Fluid Temperature	-20°C to +80°C (-4°F to +176°F)		
Viscosity	Recommended	10 to 650 cSt (mm <sup>2</sup> /s)	
	Permitted	20 to 30 cSt (mm <sup>2</sup> /s)	
Filtration	ISO Class 4406 (1999) 18/16/13 (acc. NAS 1638: 7)		

**Ordering Information**

<div style="border: 1px solid black; padding: 2px; width: 40px; margin: 0 auto;">R5A</div> <p>2-Port Compensator</p>	<div style="border: 1px solid black; width: 20px; height: 20px; margin: 0 auto;"></div> <p>Nominal Size</p>	<p>—</p>	<div style="border: 1px solid black; width: 20px; height: 20px; margin: 0 auto;"></div> <p>SAE 61 Interface</p>	<div style="border: 1px solid black; padding: 2px; width: 20px; margin: 0 auto;">4</div> <p>2-Port Body</p>	<div style="border: 1px solid black; padding: 2px; width: 20px; margin: 0 auto;">1</div> <p>Plain Cap</p>	<p>—</p>	<div style="border: 1px solid black; padding: 2px; width: 20px; margin: 0 auto;">01</div> <p>Pilot Connection thru Port X1</p>	<div style="border: 1px solid black; width: 20px; height: 20px; margin: 0 auto;"></div> <p>Design Series</p>	<div style="border: 1px solid black; width: 20px; height: 20px; margin: 0 auto;"></div> <p>Seals</p>	<p>—</p>	<div style="border: 1px solid black; width: 20px; height: 20px; margin: 0 auto;"></div> <p>Options</p>
--	---	----------	---	---	---	----------	--	--	--	----------	--

Code	Description	Code	Size	Max. Pressure	Code	Description	Weight
06	SAE 3/4"	4	10	280 Bar (4060 PSI)	1	Nitrile	R5A06 23.6 kg (7.9 lbs.)
08	SAE 1"	5	06/08	350 Bar (5075 PSI)	5	Fluorocarbon	R5A08 4.3 kg (9.5 lbs.)
10	SAE 1-1/4"						R5A10 5.6 kg (12.3 lbs.)

**Dimensions**

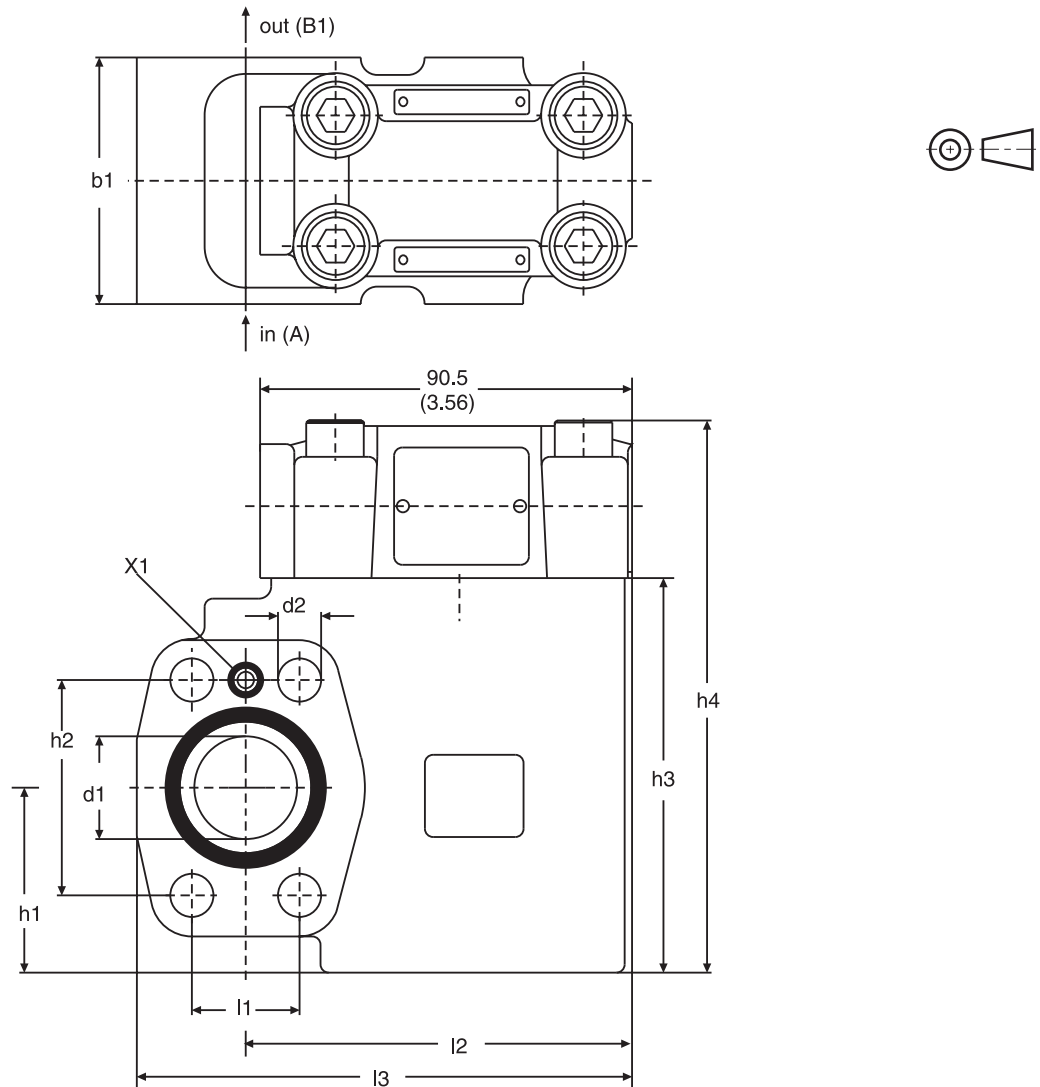

Size	l1	l2	l3	b1	h1	h2	h3	h4	d1	d2
R5A06	22.2 (0.87)	84.0 (3.31)	108.0 (4.25)	60.0 (2.36)	37.0 (1.46)	47.6 (1.87)	90.0 (3.54)	128.0 (5.04)	19.0 (0.75)	10.5 (0.41)
R5A08	26.2 (1.03)	101.0 (3.98)	128.0 (5.04)	60.0 (2.36)	45.0 (1.77)	52.4 (2.06)	96.0 (3.78)	134.0 (5.28)	25.0 (0.98)	10.5 (0.41)
R5A10	30.2 (0.44)	101.0 (3.98)	135.0 (5.31)	75.0 (2.95)	48.0 (1.89)	58.7 (2.31)	109.0 (4.29)	147.0 (5.79)	32.0 (1.26)	12.5 (0.49)

R5A.indd, dd

### General Description

Series R5P direct operated, 3-way pressure compensators can be combined with any type of fixed or adjustable flow resistor (throttle) to provide a load compensated flow. The combination with the proportional throttle valve F5C serves as a compact 3-way flow control unit in SAE flange design. The R5P is typically used as meter-in compensator in front of the flow resistor.

The R5P is additionally equipped with a pressure relief pilot that controls the compensator cartridge and operates a system pressure relief valve. The R5P\*P2 provides a proportional relief function.

### Features

- Seated type 3-way pressure compensator.
- SAE 61 flange.
- 8.4 bar (121.8 PSI) control pressure.
- Pressure relief function (optionally proportional).
- With optional vent function.
- 3 sizes (SAE 3/4", 1", 1-1/4").
- Load compensated flow in combination with F5C.

### Specifications

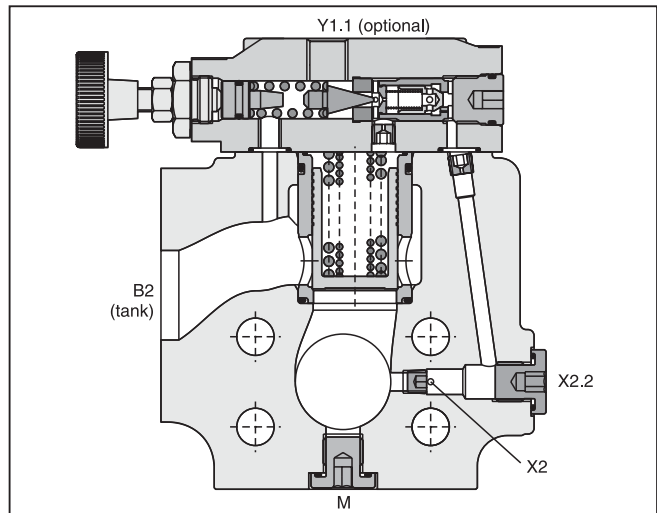
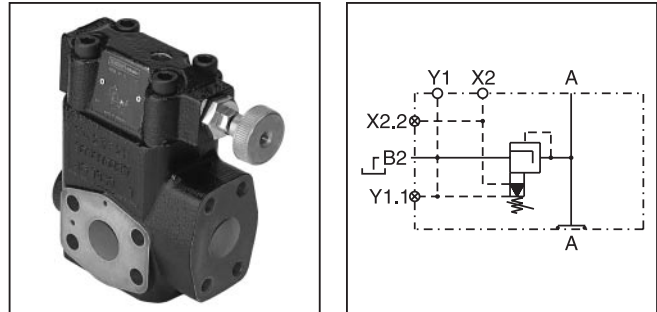

General							
Size	06		08		10		
Mounting	Flanged according to SAE 61						
Mounting Position	Unrestricted						
Ambient Temperature Range	-20°C to +50°C (-4°F to +122°F)						
Hydraulic							
Max. Operating Pressure	Ports A, B		350 Bar (5075 PSI)	350 Bar (5075 PSI)	280 Bar (4060 PSI)		
Pressure Stages	105 Bar (1523 PSI), 210 Bar (3045 PSI), 350 Bar (5075 PSI)						
Nominal Flow			90 LPM (23.8 GPM)	300 LPM (79.4 GPM)	600 LPM (158.7 GPM)		
Fluid	Hydraulic oil as per DIN 51524 ... 51525						
Fluid Temperature	-20°C to +80°C (-4°F to +176°F)						
Viscosity Permitted	10 to 650 cSt (mm <sup>2</sup> /s)						
Viscosity Recommended	30 cSt (mm <sup>2</sup> /s)						
Filtration	ISO Class 4406 (1999) 18/16/13 (acc. NAS 1638: 7)						
Electrical (Solenoid) R5P with VV01							
Duty Ratio	100%						
Solenoid Connection	Connector as per EN175301-803						
Protection Class	IP65 in accordance with EN60529 (plugged and mounted)						
	Code	G0R	G0Q	GAR	GAG	W30	W31
Supply Voltage		12V =	24V =	98V =	205V =	110V at 50Hz 120V at 60Hz	220V at 50Hz 240V at 60Hz
Tolerance Supply Voltage		+5 to -10	+5 to -10	+5 to -10	+5 to -10	±5	±5
Power Consumption	Hold	31	31	31	31	64/59 [VA]	68/62 [VA]
	In Rush	31	31	31	31	231/240 [VA]	231/240 [VA]
Response Time	Energized / De-energized AC: 20/18ms, DC: 46/27 ms						
Maximum Switching Frequency	AC: up to 7200, DC: 70 to 16,000 switchings/hour						
Coil Insulation Class	H (180°C) (356°F)						

R5Pindd, dd

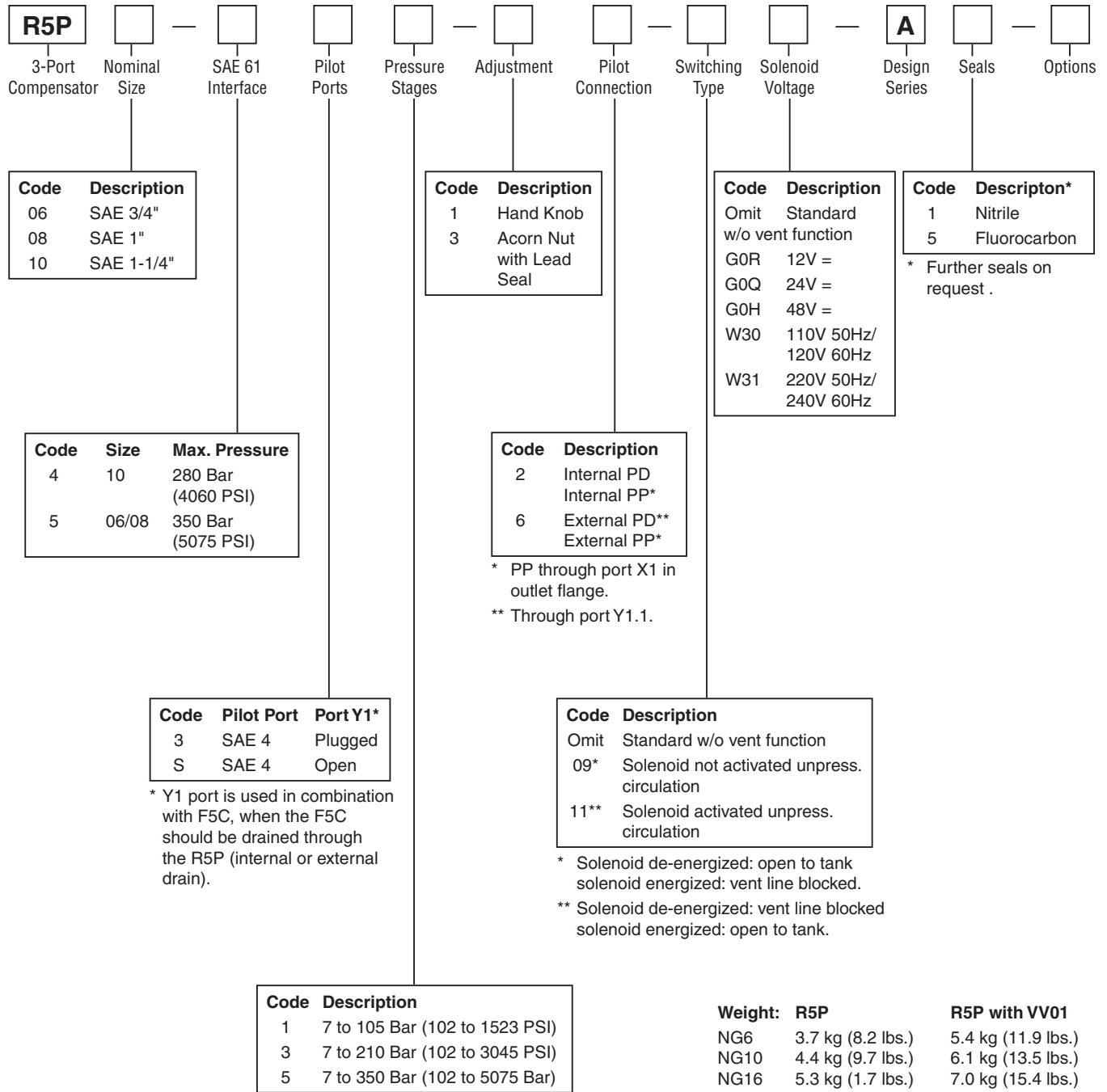



**Dimensions**

**Direct Operated Pressure Compensator Valve  
Series R5P**

Inch equivalents for millimeter dimensions are shown in (\*\*)

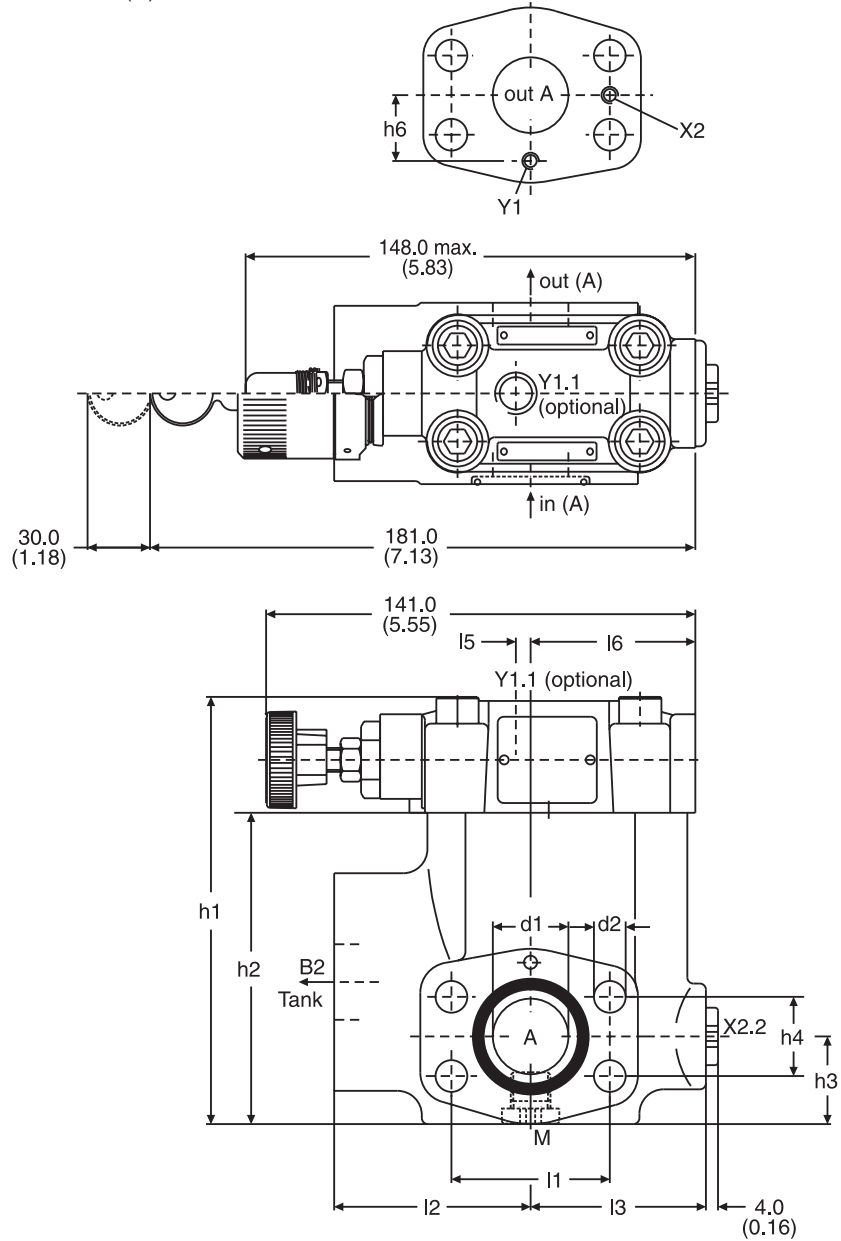

Size	I1	I2	I3	I4	I5	I6	b1	b2	h1	h2	h3	h4	h5	h6	d1	d2	d3
R5P06	47.6 (1.87)	63.0 (2.48)	56.0 (2.20)	148.0 (5.83)	1.0 (0.04)	49.0 (1.93)	60.0 (2.36)	20.0 (0.79)	119.0 (4.69)	81.6 (3.21)	28.6 (1.13)	22.2 (0.87)	41.6 (1.64)	20.8 (0.82)	19.0 (0.75)	10.5 (0.41)	3/8" UNC
R5P08	52.4 (2.06)	65.0 (2.56)	58.0 (2.28)	144.6 (5.69)	5.0 (0.20)	54.5 (2.15)	60.0 (2.36)	23.0 (0.91)	142.0 (5.59)	103.0 (4.06)	30.6 (1.20)	26.2 (1.03)	48.6 (1.91)	24.3 (0.96)	25.0 (0.98)	10.5 (0.41)	3/8" UNC
R5P10	58.7 (2.31)	61.0 (2.40)	62.0 (2.44)	146.6 (5.77)	3.0 (0.12)	56.5 (2.22)	75.0 (2.95)	22.0 (0.87)	149.0 (5.87)	111.5 (4.39)	34.6 (0.41)	30.2 (1.19)	64.1 (2.52)	29.3 (1.15)	32.0 (1.26)	12.5 (0.49)	7/16" UNC

Port	Function	Port size		
		R5P06	R5P08	R5P10
A	Inlet/Outlet	3/4"	1"	1-1/4"
B2	Tank	3/4"	1"	1-1/4"
X2	Internal Pilot Pressure	M3		
X2.2	External Pilot Pressure	SAE 4		
Y1	Internal Pilot Drain	M3		
Y1.1	External Pilot Drain	SAE 4		
M	Pressure Gauge	SAE 4		

VR5P.indd, dd



Inch equivalents for millimeter dimensions are shown in (\*\*)

**R5P with Vent Function**

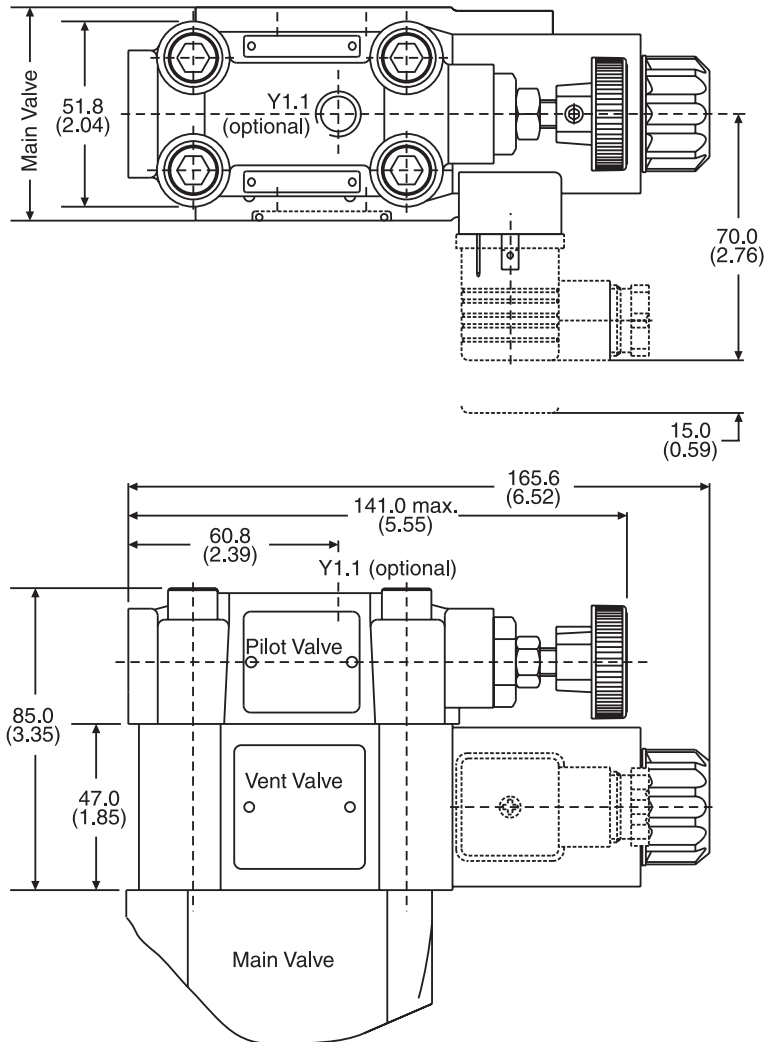

Code	Internal drain	External drain
11		
09		

R5P.indd, dd

**General Description**

Series D5S seat valves are designed for directional control functions. They enable individual hydraulic solutions for nominal flow up to 800 LPM (211.6 GPM) due to a large variety of poppets, springs and covers, including shuttle valves, stroke limiters, solenoid valves (VV01) and position control.

**Features**

- Leak-free seat valve design.
- 2- and 3-port bodies.
- SAE61 flange.
- Numerous pilot options.
- 6 poppet types.
- 4 sizes (SAE 3/4", 1", 1 1/4", 1 1/2").

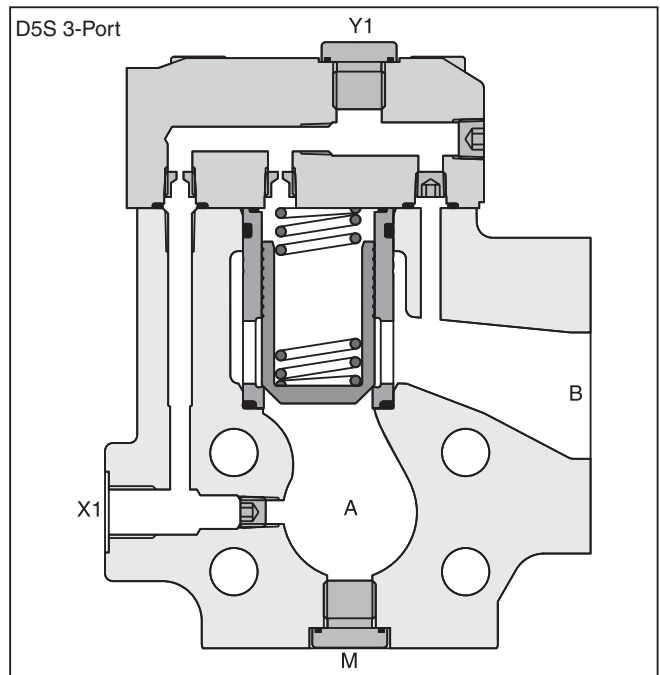
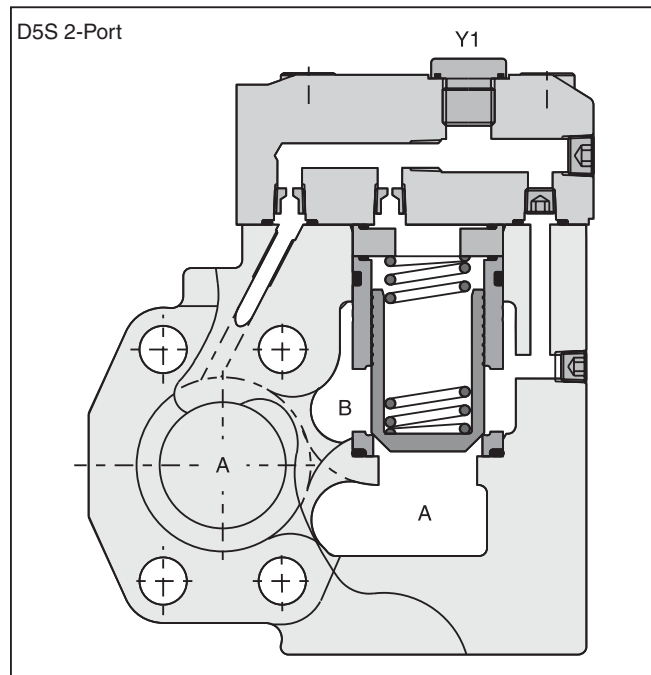
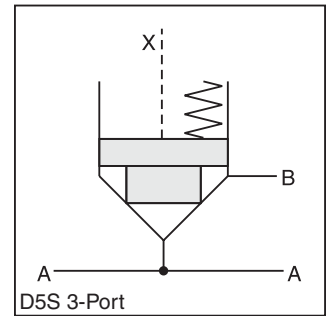
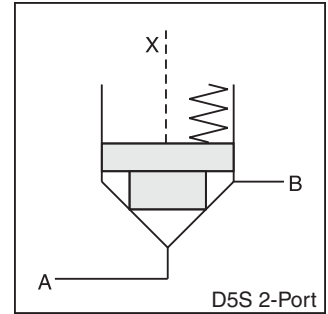

**Specifications**

General						
<b>Size</b>		<b>06</b>	<b>08</b>	<b>10</b>	<b>12</b>	
<b>Mounting</b>	Flanged according to SAE 61					
<b>Mounting Position</b>	Unrestricted					
<b>Ambient Temperature Range</b>	-20°C to +50°C (-4°F to +122°F)					
Hydraulic						
<b>Maximum Operating Pressure</b>	<b>SAE 61 Ports A, B</b>	350 Bar (5075 PSI)	350 Bar (5075 PSI)	280 Bar (4060 PSI)	210 Bar (3045 PSI)	
	<b>Port Y1</b>	30 Bar (435 PSI)	30 Bar (435 PSI)	30 Bar (435 PSI)	30 Bar (435 PSI)	
<b>Nominal Flow</b>		180 LPM (47.6 GPM)	360 LPM (95.2 GPM)	600 LPM (158.7 GPM)	800 LPM (211.6 GPM)	
<b>Fluid</b>	Hydraulic oil as per DIN 51524 ... 51525					
<b>Fluid Temperature</b>	-20°C to +80°C (-4°F to +176°F)					
<b>Viscosity Permitted</b>	10 to 650 cSt (mm <sup>2</sup> /s)					
<b>Viscosity Recommended</b>	30 cSt (mm <sup>2</sup> /s)					
<b>Filtration</b>	ISO Class 4406 (1999) 18/16/13 (acc. NAS 1638: 7)					
Electrical (Solenoid)						
<b>Duty Ratio</b>	100%					
<b>Response Time</b>	Energized / De-energized AC: 20/18ms, DC: 46/27 ms					
<b>Protection Class</b>	IP65 in accordance with EN60529 (plugged and mounted)					
	<b>Code</b>	<b>G0R</b>	<b>G0Q</b>	<b>GAR</b>	<b>GAG</b>	<b>W30</b> <b>W31</b>
<b>Supply Voltage</b>		12V =	24V =	98V =	205V =	110V at 50Hz 120V at 60 Hz      220V at 50Hz 240V at 60Hz
<b>Tolerance Supply Voltage</b>		+5 to -10	+5 to -10	+5 to -10	+5 to -10	±5                      ±5
<b>Power Consumption</b>	<b>Hold</b>	31	31	31	31	64/59 [VA]      68/62 [VA]
	<b>In Rush</b>	31	31	31	31	231/240 [VA]      231/240 [VA]
<b>Maximum Switching Frequency</b>	AC: up to 7200; DC: up to 16,000 switchings/hour					
<b>Solenoid Connection</b>	Connector as per EN175301-803					
<b>Protection Class</b>	IP65 in accordance with EN 60529 (plugged and mounted)					
<b>Coil Insulation Class</b>	H (180°C) (356°F)					

**D5S Pilot Configuration**

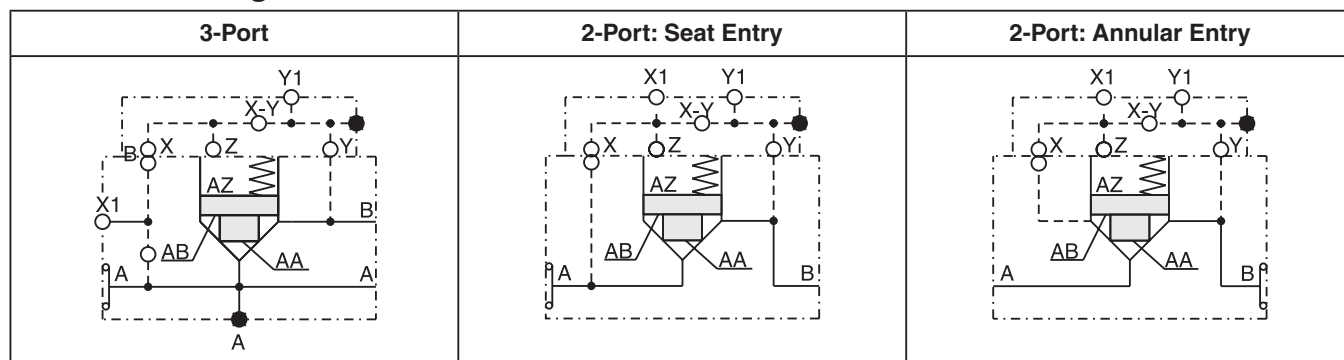

**D5S**  
 Seat Valve

Nominal Size

Body

Pilot Body Configuration

Pilot Cap

Sleeve

Spool Type

Code	Description
06	SAE 3/4"
08	SAE 1"
10	SAE 1-1/4"
12*	SAE 1-1/2"

\* D5S 3-Port only

Code	Body	Ports
9	3-Port	Seat entry, A; X1, Y1, M = SAE 4
1	2-Port	Seat entry, A; X1, Y1, M = SAE 4
2	2-Port	Annular entry, B; X1, Y1, M = SAE 4

Code	Pilot Oil Line in Body
1	Internal from A
2	Internal from B
3	Internal from A and B
4	External from X1
5	Internal from B, External from X1

Code	Description
1	AA=95%, AB=5%
3	AA=60%, AB=40%

Code	Body	Ports	X	Y	Z	X-Y	X1	Y1	VV01
<b>Standard</b>									
1	2 and 3-Port	Pilot Oil = Pilot Drain	●	●	●	○	-	●	-
2	2 and 3-Port	Pilot Oil = Pilot Drain	●	●	●	○	-	●	-
3	2-Port	Pilot Oil = Pilot Drain	●	●	●	○	○	●	-
<b>With Solenoid Valve (VV01)</b>									
4	2 and 3-Port	Internal to B	●	○	●	●	-	●	○
5	2-Port	Internal to B	●	○	●	●	○	●	○
6	2 and 3-Port	External Out of Cap	●	○	●	●	-	○	●
7	2-Port	External Out of Cap	●	○	●	●	○	○	●
<b>With Stroke Limiter (not for D5S06)</b>									
A	2 and 3-Port	Pilot Oil = Pilot Drain	●	●	●	-	●	-	-
B	2 and 3-Port	Pilot Oil = Pilot Drain	●	●	-	-	●	-	-
C	2-Port	Pilot Oil = Pilot Drain	●	●	●	-	○	-	-

Code	Size	Poppet Type	Sleeve
1	06, 08, 10, 12	With closed bottom and 15° chamfer (pZ max. = pA +20 Bar (290 PSI))	1
2	06	With 0.8 dia. orifice at the bottom and 15° chamfer	1
	08, 10	With 1.2 dia. orifice at the bottom and 15° chamfer	1
4	06, 08, 10, 12	With closed bottom and 45° chamfer	1, 3
A*	08, 10, 12	Safety spool (for end position control only)	3
B*	08, 10, 12	Throttle spool, 10° chamfer	3
C*	08, 10, 12	Throttle spool, 3° chamfer	3

**Key:** ○ Open Bore ● Closed Bore ● Orifice ∅ 1.2  
**Note:** Combination examples provided on pages 26-30.

\* Springs 2, 3, 4, and 6 only



Code	Description
omit	Standard w/o vent function
G0R	12V =
G0Q	24V =
G0H	98V =
GAG	205V=
W30	110V 50Hz / 120V 60Hz
W31	220V 50Hz / 240V 60Hz

Code	Description
1	Nitrile
5	Fluorocarbon

Code	Description
Omit	Standard
013	Position Control with Protection

Code	Description	
omit	Standard without Vent Function	
09	VV01 with Manual Override	De-energized; power comp. open
10	VV01 without Manual Override	
11	VV01 with Manual Override	De-energized; power comp. closed
12	VV01 without Manual Override	
CA	Shuttle Valve	
DA	Shuttle Valve	
CB	VV01 Code 09 and Shuttle Valve Code CA	
CD	VV01 Code 11 and Shuttle Valve Code CA	
DB	VV01 Code 09 and Shuttle Valve Code DA	
DD	VV01 Code 11 and Shuttle Valve Code DA	
BH	VV01 Code 10 and Shuttle Valve Code CA and Position Control* with Amplifier	
BK	VV01 Code 12 and Shuttle Valve Code CA and Position Control* with Amplifier	
BN	VV01 Code 10 and Shuttle Valve Code DA and Position Control* with Amplifier	
BQ	VV01 Code 12 and Shuttle Valve Code DA and Position Control* with Amplifier	
BC	VV01 Code 10 and Position Control* with Amplifier	
BE	VV01 Code 12 and Position Control* with Amplifier	
BA	Position Control* with Amplifier	
BF	Position Control* with Amplifier and Shuttle Valve Code CA	
BL	Position Control* with Amplifier and Shuttle Valve Code DA	

Weight:	D5S 2-Port	D5S 3-Port
D5S06	3.6 kg (7.9 lbs)	3.4 kg (7.5 lbs)
D5S08	4.1 kg (9.0 lbs)	4.4 kg (9.7 lbs)
D5S10	5.4 kg (11.9 lbs)	5.0 kg (11.0 lbs)
D5S12	–	7.8 kg (17.2 lbs)

\* Position control for D5S08/10 only.  
 Spring 2 or 4. Spool A and sleeve 3.

Code	Spring — Approx. Cracking Pressure in Bar (PSI)					
	Sleeve Code 1			Sleeve Code 3		
	A -> B		A -> B		B -> A	
	D5S06	D5S08/12	D5S06	D5S08/12	D5S06	D5S08/12
1	2.8 (40.6)	3.5 (50.8)	6.5 (94.3)	6.5 (94.3)	9.5 (137.8)	11.0 (159.5)
2	0.5 (7.3)	0.5 (7.3)	1.0 (14.5)	1.0 (14.5)	1.5 (21.8)	1.7 (24.7)
3	0.3 (4.4)	0.3 (4.4)	0.6 (8.7)	0.6 (8.7)	0.9 (13.1)	1.0 (14.5)
4	2.2 (31.9)	2.2 (31.9)	4.0 (58.0)	3.5 (50.8)	5.5 (79.8)	6.0 (87.0)
5	–	9.0 (130.5)	–	16.0 (232.0)	–	28.0 (406.0)
6	1.2 (17.4)	1.2 (17.4)	2.0 (29.0)	2.2 (31.9)	3.0 (43.5)	3.8 (55.1)
7	3.0 (43.5)	–	8.0 (116.0)	–	12.0 (174.0)	–

**D5S 2-Port Examples**

**Seat Entry**

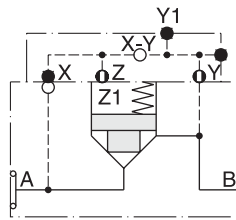

D5S...-122-  
7

Pilot oil: internal from B

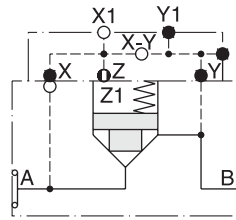

D5S...-143-  
7

Pilot oil: external from X1

**Annular Entry**

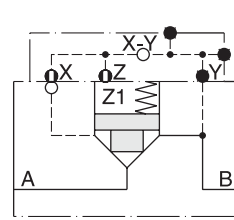

D5S...-221-  
8

Pilot oil: internal from B

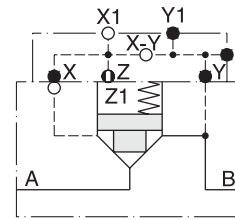

D5S...-243-  
8

Pilot oil: external from X1

**Stroke Limiter D5S 2-Port Examples**

**Seat Entry**

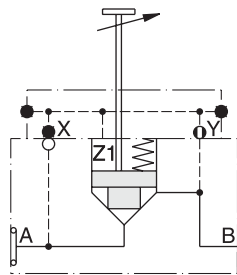

D5S08-12B-  
10 7

Pilot oil: internal from B

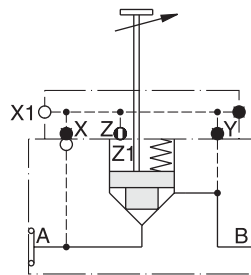

D5S08-14C-  
107

Pilot oil: external from X1

**Annular Entry**

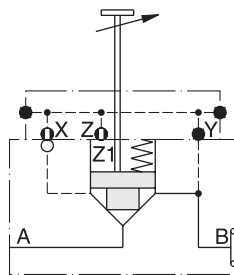

D5S08-22A-  
10 8

Pilot oil: internal from B

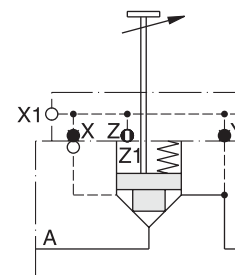

D5S08-24C-  
108

Pilot oil: external from X1

**D5S 3-Port Examples**

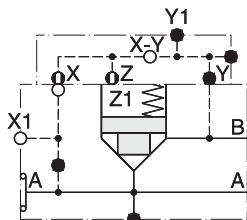

D5S .. -541-  
9

Pilot oil: external from X1

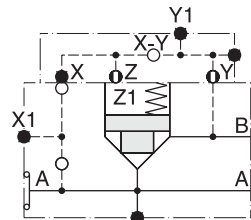

D5S .. -522-  
9

Pilot oil: internal from B

**Stroke Limiter D5S 3-Port Examples**

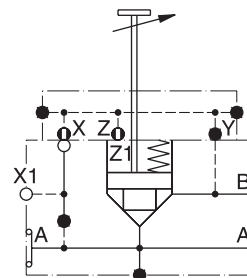

D5S 08 -54A-  
10 9  
12

Pilot oil: external from X1

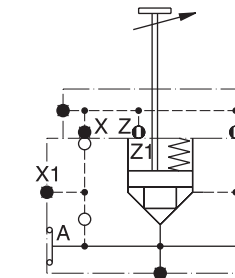

D5S 08 -52B-  
10 9  
12

Pilot oil: internal from B

**D5S 2-Port with Solenoid Valve VV01 Examples**

**Seat Entry**

**Annular Entry**

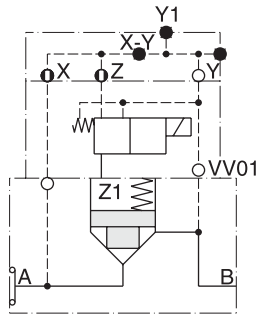

D5S .. -114-09-  
 7 10  
 11  
 12

Pilot oil: internal from A  
 Pilot drain: internal to B

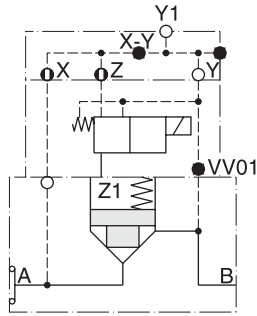

D5S .. -116-09-  
 7 10  
 11  
 12

Pilot oil: internal from A  
 Pilot drain: external out of Y1

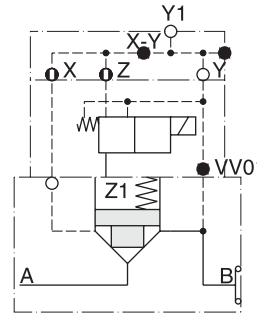

D5S .. -226-09-  
 8 10  
 11  
 12

Pilot oil: internal from B  
 Pilot drain: external out of Y1

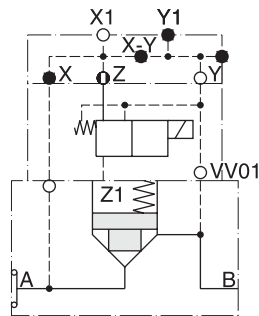

D5S .. -145-09-  
 7 10  
 11  
 12

Pilot oil: internal from X1  
 Pilot drain: internal to B

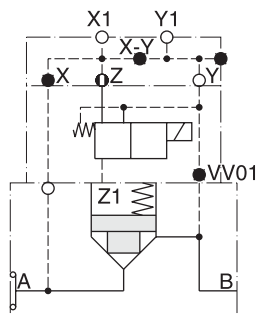

D5S .. -147-09-  
 7 10  
 11  
 12

Pilot oil: internal from X1  
 Pilot drain: external out of Y1

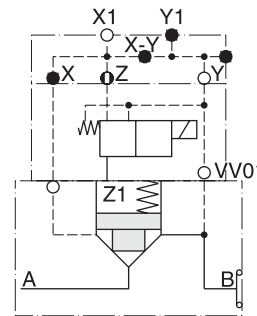

D5S .. -245-09-  
 8 10  
 11  
 12

Pilot oil: internal from X1  
 Pilot drain: internal to B

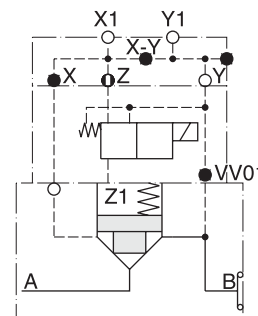

D5S .. -247-09-  
 8 10  
 11  
 12

Pilot oil: internal from X1  
 Pilot drain: external out of Y1

**D5S 2-Port with Solenoid Valve VV01 and Shuttle Valve Examples**

**Seat Entry**

**Annular Entry**

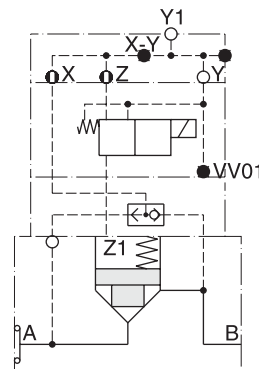

D5S .. -136-...-CB-  
 7 CD

Pilot oil: internal from A +  
 internal from B  
 Pilot drain: external out of Y1

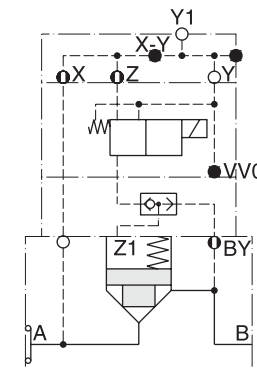

D5S .. -136-...-DB-  
 7 DD

Pilot oil: internal from A +  
 internal from B  
 Pilot drain: external out of Y1

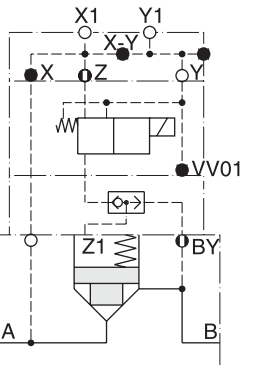

D5S .. -157-...-DB-  
 7 DD

Pilot oil: external from X1 +  
 internal from B  
 Pilot drain: external out of Y1

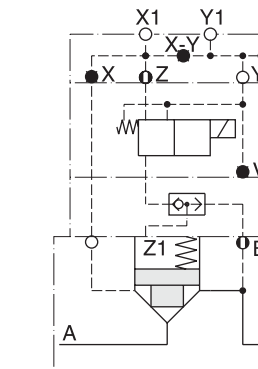

D5S .. -857-...-DB-  
 2 DD

Pilot oil: external from X1 +  
 internal from B  
 Pilot drain: external out of Y1



**D5S 3-Port with Solenoid Valve VV01 Examples**

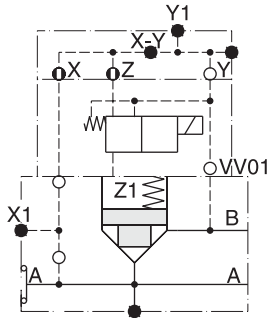

D5S ..-514-09-  
 9 10  
 11  
 12

Pilot oil: internal from A  
 Pilot drain: internal to B

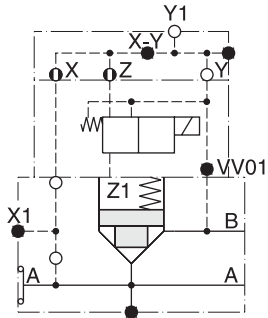

D5S ..-516-09-  
 9 10  
 11  
 12

Pilot oil: internal from A  
 Pilot drain: external out of Y1

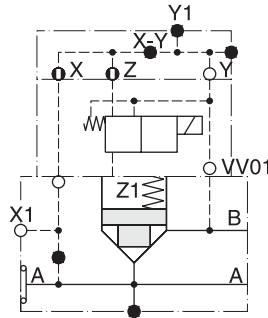

D5S ..-544-09-  
 9 10  
 11  
 12

Pilot oil: external from X1  
 Pilot drain: internal to B

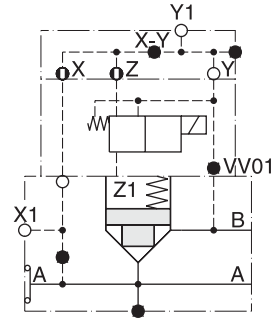

D5S ..-546-09-  
 9 10  
 11  
 12

Pilot oil: external from X1  
 Pilot drain: external out of Y1

**D5S 3-Port with Solenoid Valve VV01 and Shuttle Valve Examples**

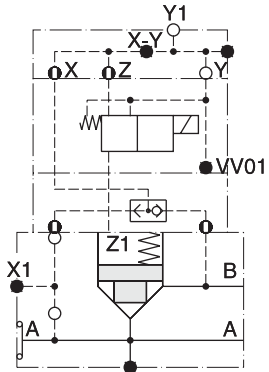

D5S ..-536-...-CB-  
 9 CD

Pilot oil: internal from A +  
 internal from B  
 Pilot drain: external out of Y1

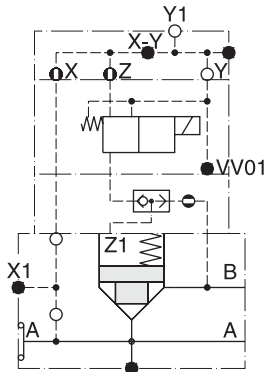

D5S ..-536-...-DB-  
 9 DD

Pilot oil: internal from A +  
 internal from B  
 Pilot drain: external out of Y1

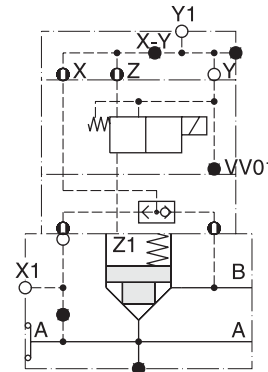

D5S ..-556-...-CB-  
 9 CD

Pilot oil: internal from X1 +  
 internal from B  
 Pilot drain: external out of Y1

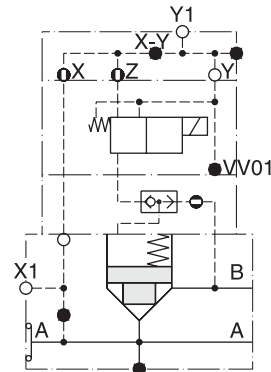

D5S ..-556-...-DB-  
 9 DD

Pilot oil: external from X1 +  
 internal from B  
 Pilot drain: external out of Y1

**D5S 2-Port Position Control Examples**

**Seat Entry**

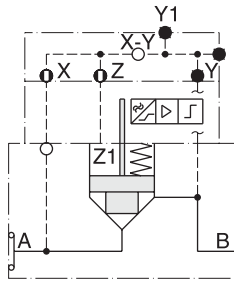

D5S 08 -111-3A.-BA-  
 D5S 10 7  
 Pilot oil: internal from A

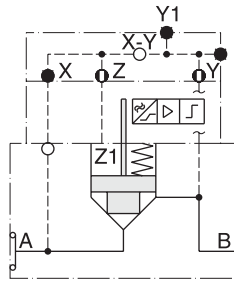

D5S 08 -122-3A.-BA-  
 D5S 10 7  
 Pilot oil: internal from B

**Annular Entry**

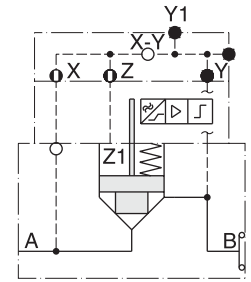

D5S 08 -221-3A.-BA-  
 D5S 10 8  
 Pilot oil: internal from B

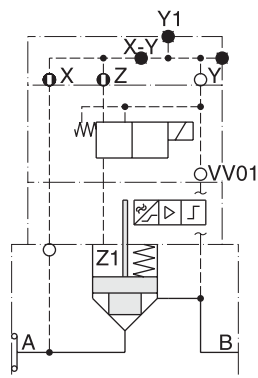

D5S 08 -114-3A.-BC-  
 D5S 10 7 BE  
 Pilot oil: internal from A  
 Pilot drain: internal to B

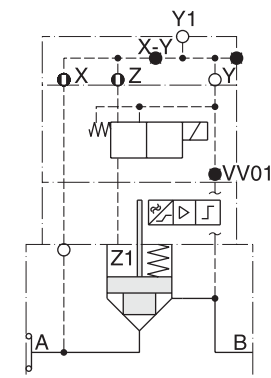

D5S 08 -116-3A.-BC-  
 D5S 10 7 BE  
 Pilot oil: internal from A  
 Pilot drain: external out of Y1

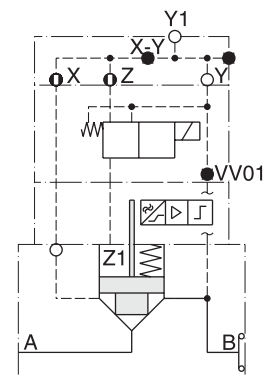

D5S 08 -226-3A.-BC-  
 D5S 10 8 BE  
 Pilot oil: internal from B  
 Pilot drain: external out of Y1

**Seat Entry**

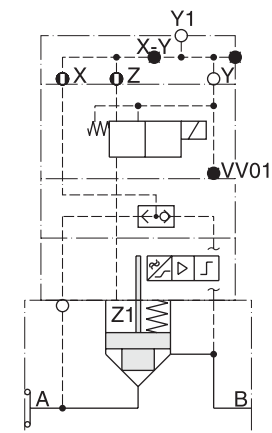

D5S ...-136-...-BH-  
 7 BK  
 Pilot oil: internal from A +  
 internal from B  
 Pilot drain: external out of Y1

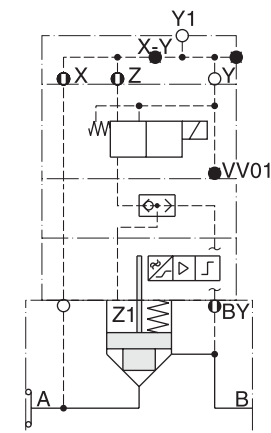

D5S ...-136-...-BN-  
 7 BQ  
 Pilot oil: internal from A +  
 internal from B  
 Pilot drain: external out of Y1

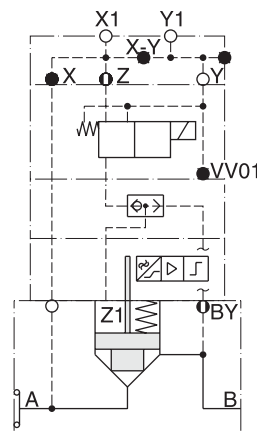

D5S ...-157-...-BN-  
 7 BQ  
 Pilot oil: external from X1 +  
 internal from B  
 Pilot drain: external out of Y1

**Annular Entry**

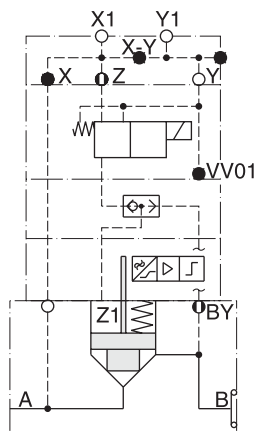

D5S ...-857-...-BN-  
 2 BQ  
 Pilot oil: external from X1 +  
 internal from B  
 Pilot drain: external out of Y1

**D5S 3-Port Position Control Examples**

**Seat Entry**

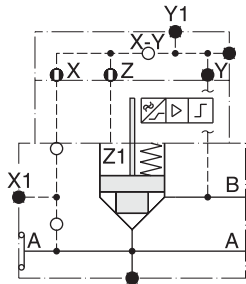

D5S 08 -511-3A.-BA-  
 10 9  
 12  
 Pilot oil: internal from A

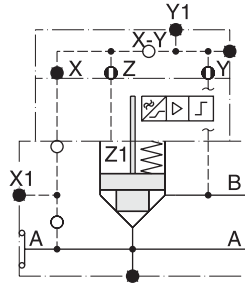

D5S 08 -522-3A.-BA-  
 10 9  
 12  
 Pilot oil: internal from B

**Annular Entry**

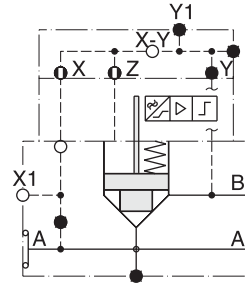

D5S 08 -521-3A.-BA-  
 10 9  
 12  
 Pilot oil: external from X1

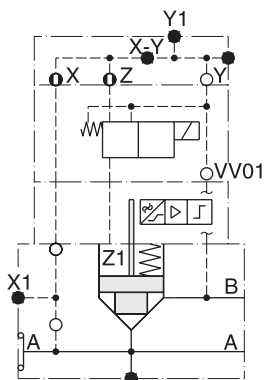

D5S 08 -514-3A.-BC-  
 10 9 BE  
 12  
 Pilot oil: internal from A  
 Pilot drain: internal to B

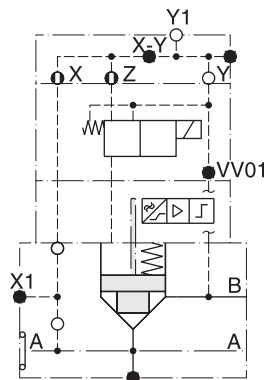

D5S 08 -516-3A.-BC  
 10 9 BE  
 12  
 Pilot oil: internal from A  
 Pilot drain: external out of Y1

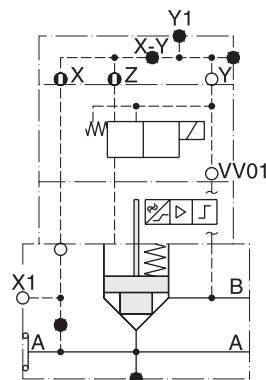

D5S 08 -544-3A.-BC-  
 10 9 BE  
 12  
 Pilot oil: external from X1  
 Pilot drain: internal to B

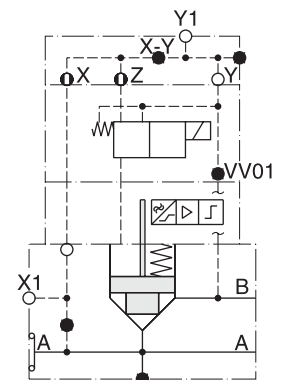

D5S 08 -546-3A.-BC-  
 10 9 BE  
 12  
 Pilot oil: external from X1  
 Pilot drain: external out of Y1

**Seat Entry**

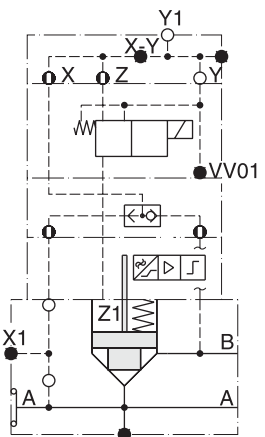

D5S 08 -536-3A.-BH-  
 10 9 BE  
 12  
 Pilot oil: internal from A +  
 internal from B  
 Pilot drain: external out of Y1

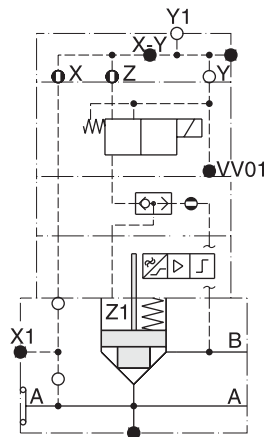

D5S 08 -536-3A.-BN-  
 10 9 BQ  
 12  
 Pilot oil: internal from A +  
 internal from B  
 Pilot drain: external out of Y1

**Annular Entry**

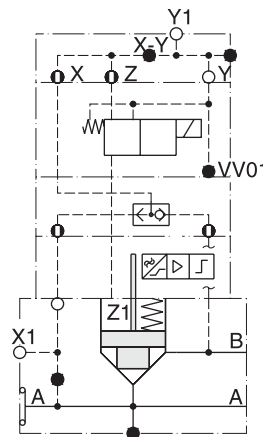

D5S 08 -556-3A.-BH-  
 10 9 BK  
 12  
 Pilot oil: external from X1 +  
 internal from B  
 Pilot drain: external out of Y1

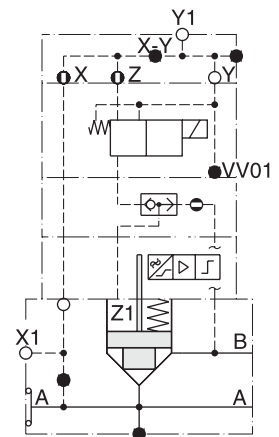

D5S 08 -556-3A.-BN-  
 10 9 BQ  
 12  
 Pilot oil: external from X1 +  
 internal from B  
 Pilot drain: external out of Y1

**Performance Curves**

**D5S 2-Port\***

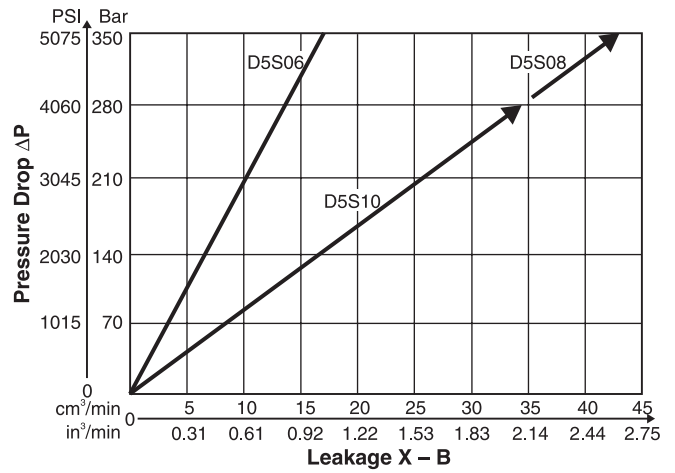
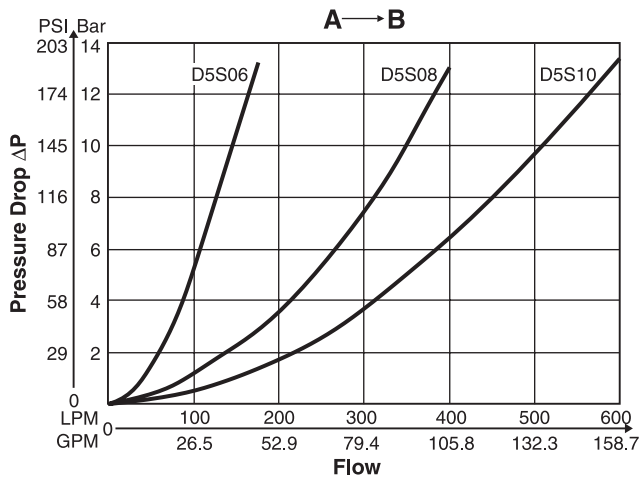

**D5S 3-Port\***

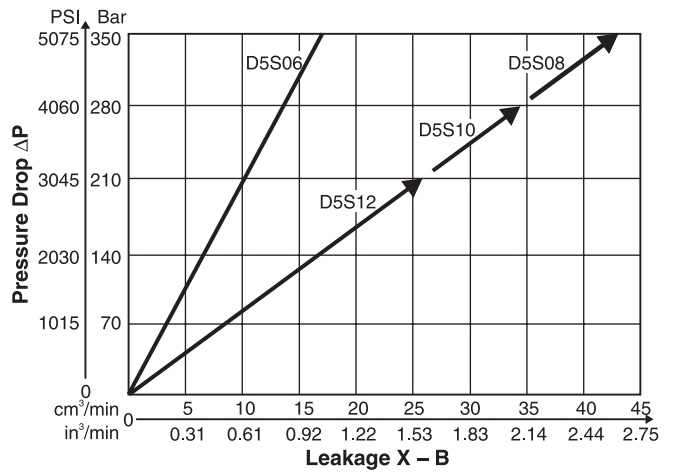
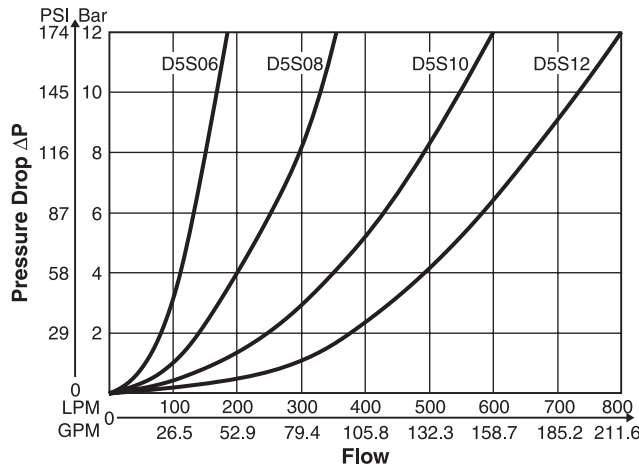

\*Fluid viscosity 38cSt at 50°C (122°F)

**Selection of Cartridges**

Sleeve 1, Poppet 1	Sleeve 1, Poppet 2	Sleeve 1, Poppet 4	Sleeve 3, Poppet 4	Sleeve 3, Poppet A	Sleeve 3, Poppet B/C
1 : 1.05 A <sub>A</sub> = 0.95 A <sub>C</sub> A <sub>B</sub> = 0.95 A <sub>C</sub> 15° chamfer	1 : 1.05 A <sub>A</sub> = 0.95 A <sub>C</sub> A <sub>B</sub> = 0.95 A <sub>C</sub> 15° chamfer orifice	1 : 1.05 A <sub>A</sub> = 0.95 A <sub>C</sub> A <sub>B</sub> = 0.95 A <sub>C</sub> 45° chamfer	1 : 1.67 A <sub>A</sub> = 0.6 A <sub>C</sub> A <sub>B</sub> = 0.4 A <sub>C</sub> 45° chamfer	1 : 1.67 A <sub>A</sub> = 0.6 A <sub>C</sub> A <sub>B</sub> = 0.4 A <sub>C</sub> 45° chamfer safety spool	1 : 1.67 A <sub>A</sub> = 0.6 A <sub>C</sub> A <sub>B</sub> = 0.4 A <sub>C</sub> 45° chamfer throttle spool

D5S.indd, dd

**Example Pilot Oil External from X1, Pilot Drain Internal Out of B with Vent Valve**

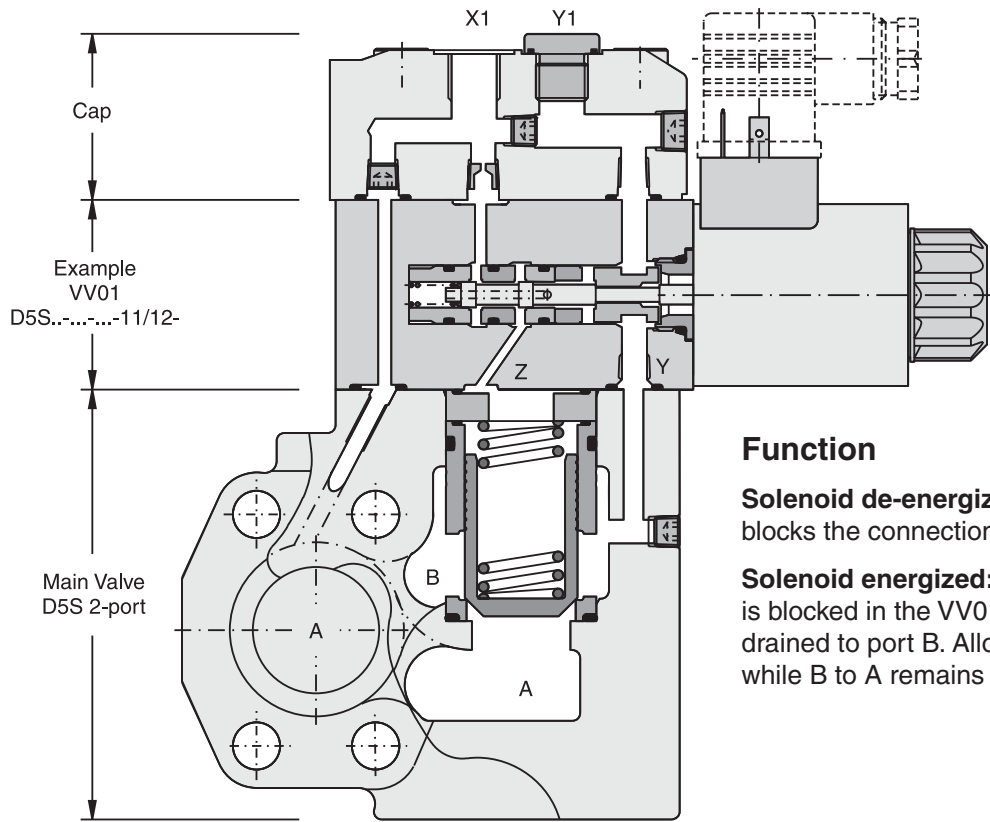

**Function**

**Solenoid de-energized:** Pilot oil from X1 to Z blocks the connection from A to B or B to A.

**Solenoid energized:** Pilot pressure from X1 is blocked in the VV01. The oil in Z is internally drained to port B. Allowing flow from A to B, while B to A remains blocked.

**Dimensions — D5S with VV01**

Inch equivalents for millimeter dimensions are shown in (\*\*)

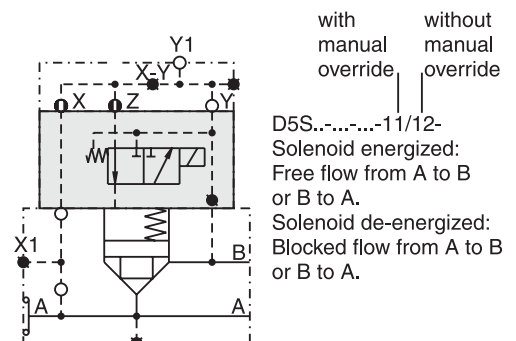
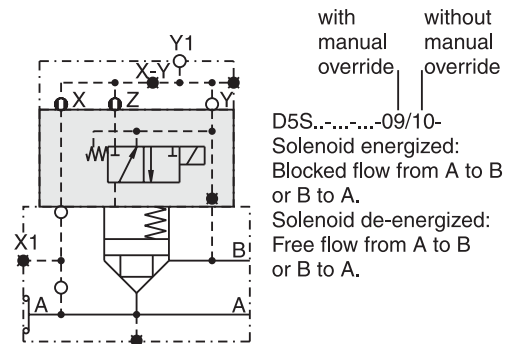
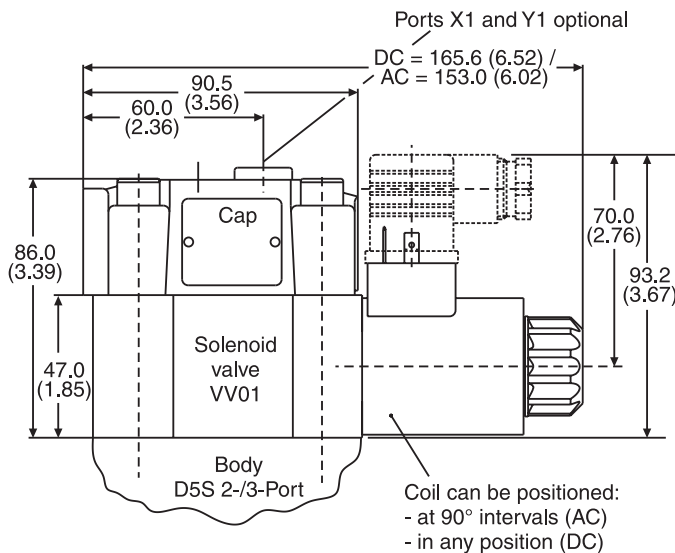

**Example Pilot Oil External from X1, Pilot Drain Internal Out of B with Position Control**

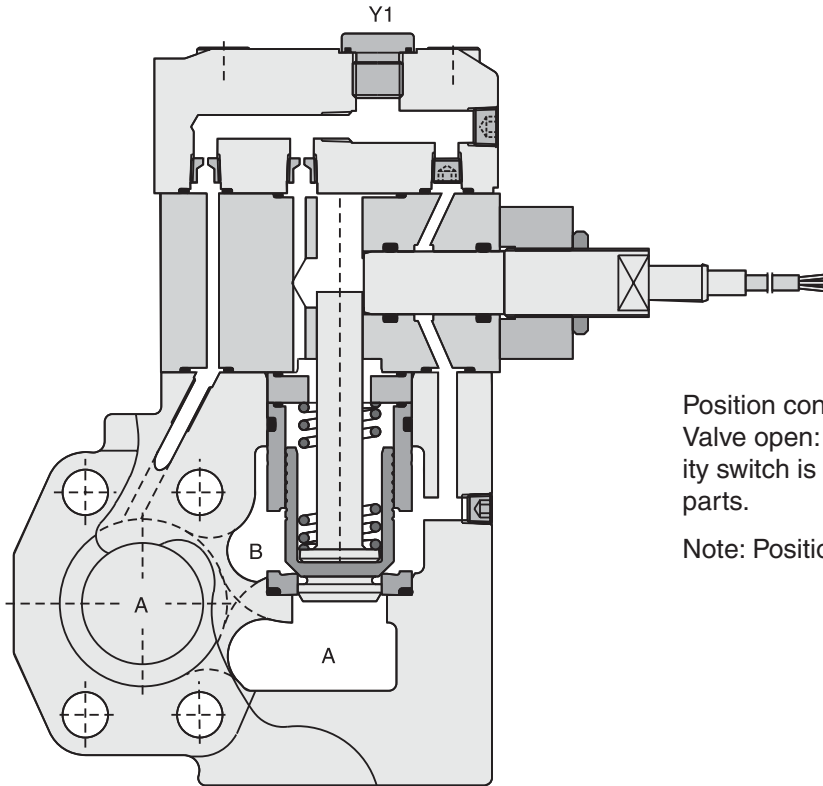

Position control by proximity switch (incl. amplifier). Valve open: proximity switch activated. This proximity switch is pressure proof and has no wearing parts.

Note: Position control for D5S08 and D5S10 only.

**Dimensions — D5S with Position Control**

Inch equivalents for millimeter dimensions are shown in (\*\*)

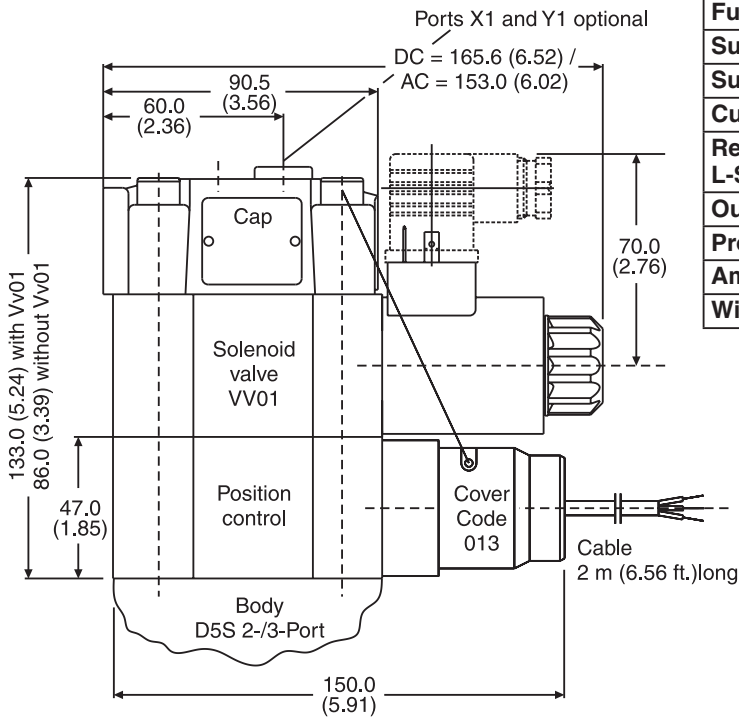

**Technical Data (Proximity Switch)**

<b>Function</b>	PNP, contact
<b>Supply Voltage</b>	10 - 30VDC
<b>Supply Voltage Ripple</b>	≤10%
<b>Current Consumption</b>	8mA Maximum
<b>Residual Voltage L-Signal</b>	$U_s - 2.2V$ at $I_{max}$
<b>Output Current</b>	≤200 mA
<b>Protection Class</b>	IP67
<b>Ambient Temperature</b>	-25°C to +70°C (-13°F to +159°F)
<b>Wire Cross Section</b>	3 x 0.5 mm <sup>2</sup>

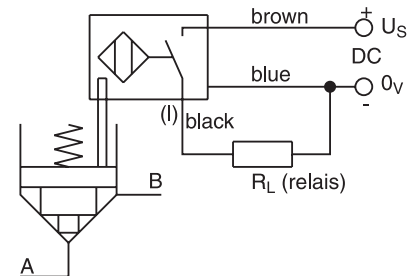
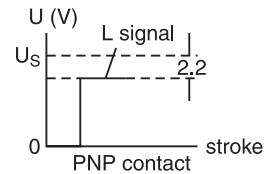

Inch equivalents for millimeter dimensions are shown in (\*\*)

**D5S Stroke Limiter**

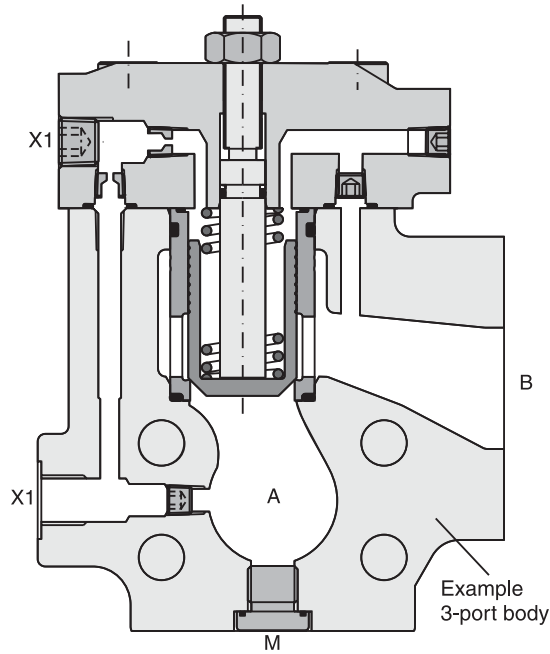

X1 = external pilot-oil (optional)

**Note:** Stroke limiter not for use with D5S06, solenoid valve VV01, shuttle valve and position control.

**D5S Stroke Limiter Dimensions**

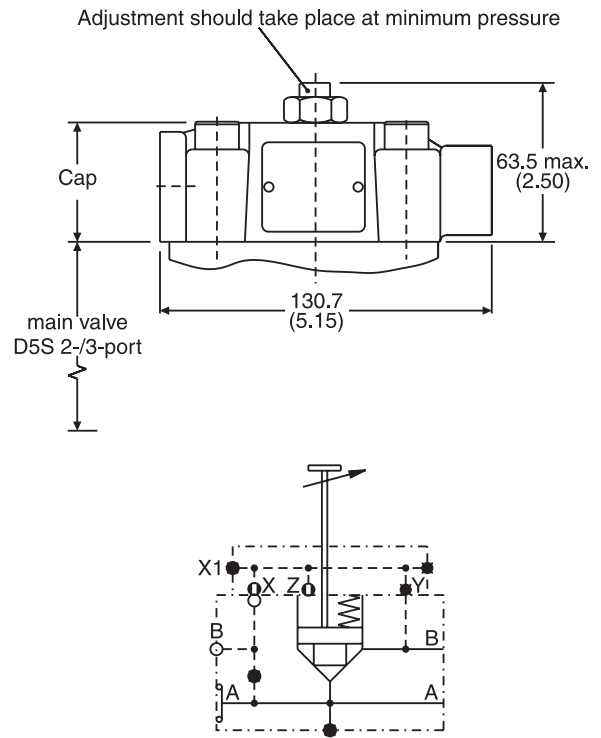

**D5S with Shuttle Valve Dimensions**

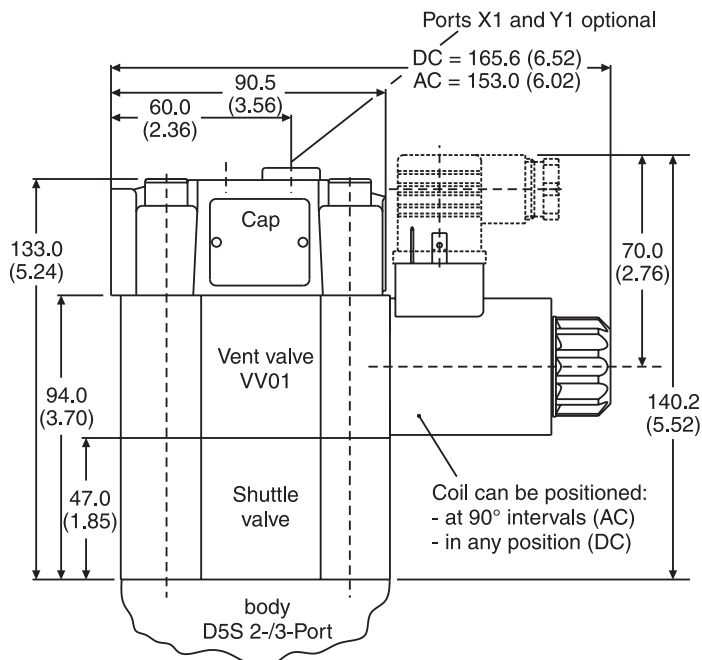

Shuttle valve only in connection with vent valve VV01.

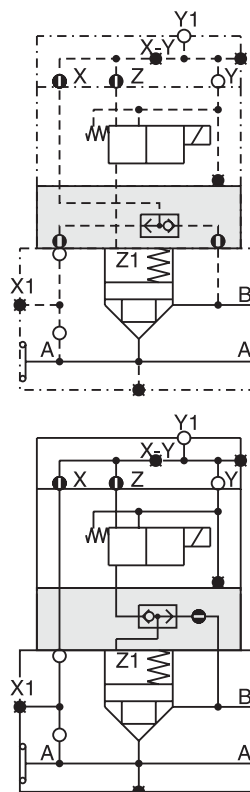

1) pilot oil from A and B, from B to A check valve function

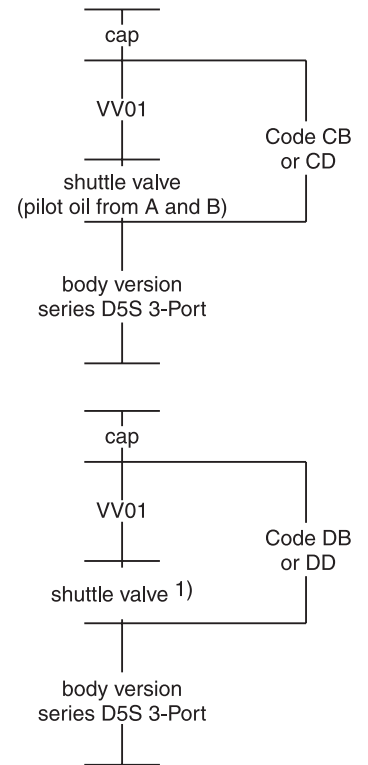

Inch equivalents for millimeter dimensions are shown in (\*\*)

**2-Port**

**Seat Entry**

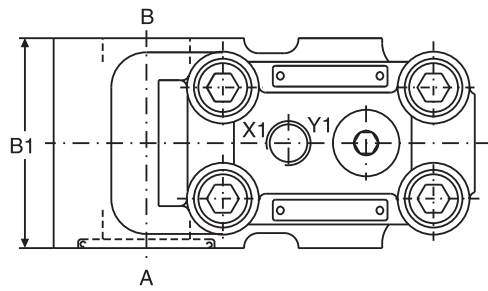

**Annular Entry**

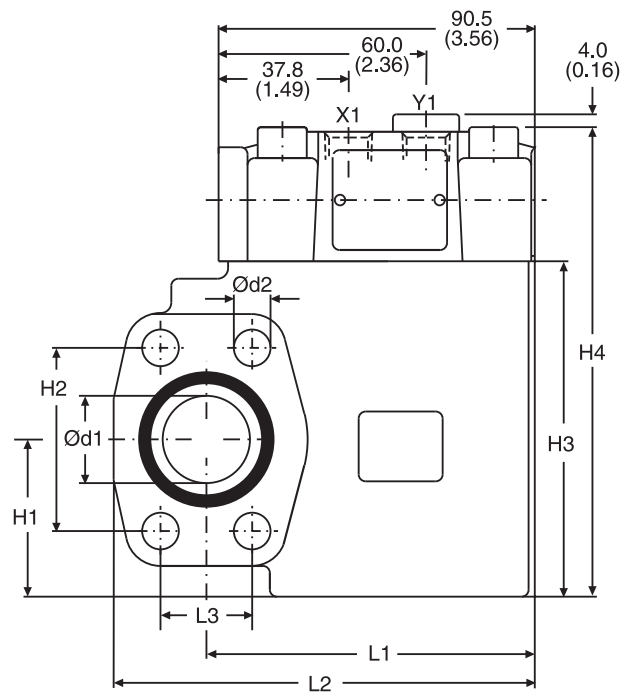
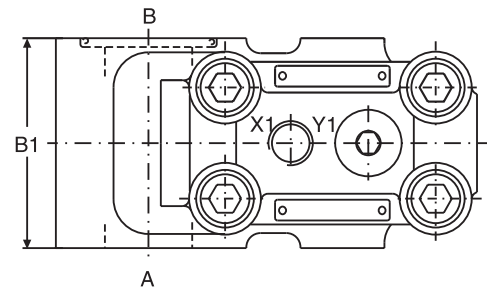

Ports X1 and Y1 optional

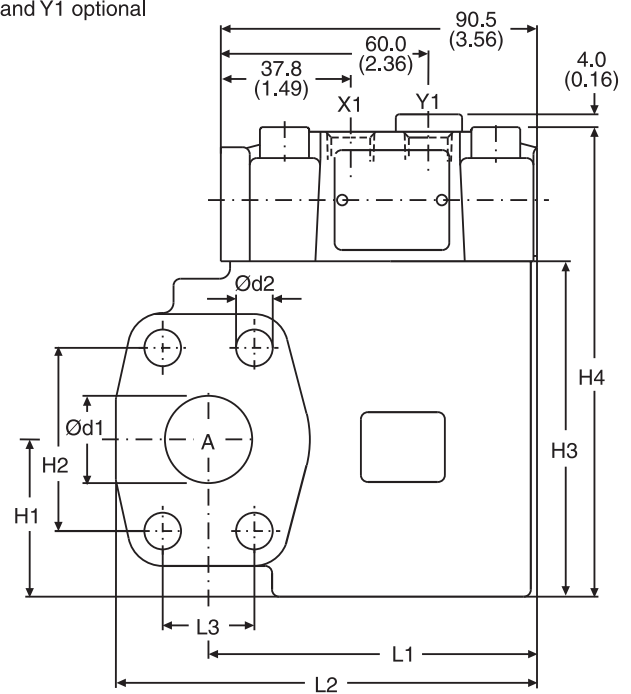

Size	I1	I2	I3	b1	h1	h2	h3	h4	d1	d2
06	77.0 (3.03)	101.0 (3.98)	22.2 (0.87)	60.0 (2.36)	37.0 (1.46)	47.6 (1.87)	90.0 (3.54)	127.6 (5.02)	19.0 (0.75)	10.5 (0.41)
08	94.0 (3.70)	120.5 (4.74)	26.2 (1.03)	60.0 (2.36)	45.0 (1.77)	52.4 (2.06)	96.0 (3.78)	133.6 (5.26)	25.0 (0.98)	10.5 (0.41)
10	94.0 (3.70)	128.0 (5.04)	30.2 (1.19)	75.0 (2.95)	48.0 (1.89)	58.7 (2.31)	109.0 (4.29)	146.6 (5.77)	32.0 (1.26)	12.5 (0.49)

Ports	Function	Port size		
		D5S06	D5S08	D5S10
A	Inlet or outlet	3/4" SAE 61	1" SAE 61	1-1/4" SAE 61
B	Outlet or inlet	3/4" SAE 61	1" SAE 61	1-1/4" SAE 61
X1	External pilot port	SAE 4		
Y1	External pilot drain			





## General Description

Series R4V pilot operated pressure relief valves for in-line mounting have a similar design to the subplate mounted R4V series. For single functions where no manifold blocks are used the valves can be directly placed in the pipework.

The R4V valves are available with 2 ports (L-body) for in-line relief function or with 3 ports (T-body) for relief functions in the bypass.

## Operation

The system pressure in Port A is applied to the pilot valve and to the top surface of the main poppet via an orifice in X. The hydraulically balanced main poppet is held against the seat by the main spring. In this state there is no flow through the valve. The adjusted spring force acting on the pilot cone determines the relief pressure. If the pressure in Port A exceeds the set point, the pilot cone is lifted from its seat, releasing a small pilot flow to tank. The flow through the control orifice in X creates a pressure drop which limits the pressure at the top of the main poppet to the set point. The higher system pressure in Port A now lifts the main poppet off its seat and allows flow to Port B. In the resulting float position only enough flow is passed from Port A to Port B to maintain the inlet pressure in Port A at the set point. When the pressure in Port A falls below the set point, the hydraulic balance on the main poppet is restored. The main spring then forces the main poppet to close.

## Features

- Pilot operated with manual adjustment.
- 2 interfaces
  - L-body (R4V06-SAE 12, R4V10-SAE 20)
  - T-body (R4V03-SAE 8, R4V06-SAE 16)
- 3 pressure stages.
- 3 adjustment modes
  - Hand knob
  - Acorn nut with lead seal
  - DIN lock
- With optional vent function.

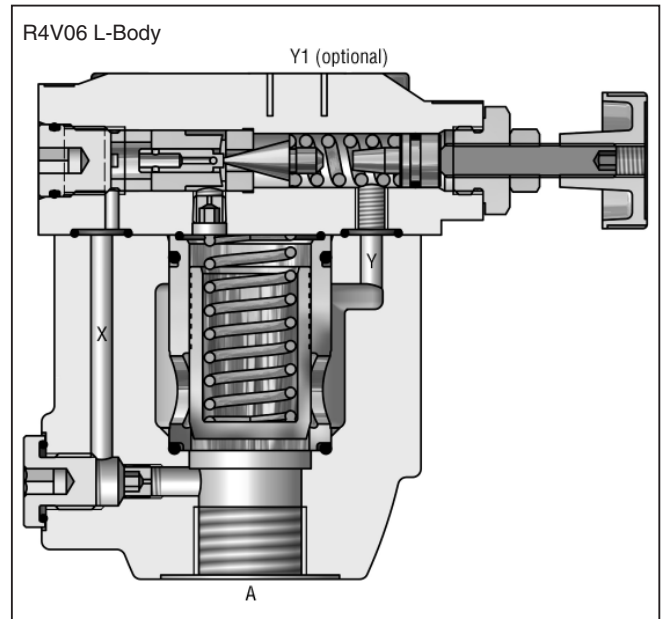
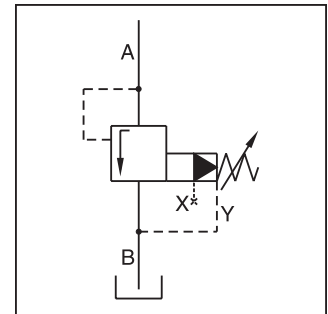

## R4V

General				
Size	T-Body		L-Body	
	03 (SAE 8)	06 (SAE 16)	06 (SAE 12)	10 (SAE 20)
Mounting	Threaded Body			
Mounting Position	Unrestricted			
Ambient Temp. Range	-20°C to +50°C (-4°F to +122°F)			
Hydraulic				
Max. Operating Pressure	Ports A and X up to 350 Bar (5075 PSI); Ports B and Y 30 Bar (435 PSI)			
Pressure Stages	105 Bar (1523 PSI), 210 Bar (3045 PSI), 350 Bar (5075 PSI)			
Nominal Flow	60 LPM (15.9 GPM)	200 LPM (52.9 GPM)	200 LPM (52.9 GPM)	450 LPM (119.0 GPM)
Fluid	Hydraulic oil as per DIN 51524 ... 51525			
Fluid Temperature	-20°C to +80°C (-4°F to +176°F)			
Viscosity Permitted	10 to 650 cSt (mm <sup>2</sup> /s)			
Viscosity Recommended	30 cSt (mm <sup>2</sup> /s)			
Filtration	ISO Class 4406 (1999) 18/16/13 (acc. NAS 1638: 7)			

## R4V with Vent Function

General							
Size	T-Body			L-Body			
	03 (SAE 8)	06 (SAE 16)	06 (SAE 12)	10 (SAE 20)			
Mounting	Threaded Body						
Mounting Position	Unrestricted						
Ambient Temp. Range	-20°C to +50°C (-4°F to +122°F)						
Weight	4.9 kg (10.8 lbs)	8.3 kg (18.3 lbs)	5.0 kg (11.0 lbs)	7.3 kg (16.1 lbs)			
Hydraulic							
Max. Operating Pressure	Ports A and X up to 350 Bar (5075 PSI); Ports B and Y 30 Bar (435 PSI)						
Pressure Stages	105 Bar (1523 PSI), 210 Bar (3045 PSI), 350 Bar (5075 PSI)						
Nominal Flow	60 LPM (15.9 GPM)	200 LPM (52.9 GPM)	200 LPM (52.9 GPM)	450 LPM (119.0 GPM)			
Fluid	Hydraulic oil as per DIN 51524 ... 51525						
Fluid Temperature	-20°C to +80°C (-4°F to +176°F)						
Viscosity Permitted	10 to 650 cSt (mm <sup>2</sup> /s)						
Viscosity Recommended	30 cSt (mm <sup>2</sup> /s)						
Filtration	ISO Class 4406 (1999) 18/16/13 (acc. NAS 1638: 7)						
Power Amplifier	PCD00A-400						
Electrical (Solenoid)							
Duty Ratio	100%						
Response Time	Energized / De-energized AC: 20/18ms, DC: 46/27 ms						
	Code	G0R	G0Q	GAR	GAG	W30	W31
Supply Voltage		12V =	24V =	98V =	205V =	110V at 50Hz 120V at 60Hz	220V at 50Hz 240V at 60Hz
Tolerance Supply Voltage		+5 to -10	+5 to -10	+5 to -10	+5 to -10	±5	±5
Power Consumption	Hold	31	31	31	31	64/59 [VA]	68/62 [VA]
	In Rush	31	31	31	31	231/240 [VA]	231/240 [VA]
Solenoid Connection	Connector as per EN175301-803						
Protection Class	IP65 in accordance with EN60529 (plugged and mounted)						
Coil Insulation Class	H (180°C) (356°F)						

**Ordering Information**

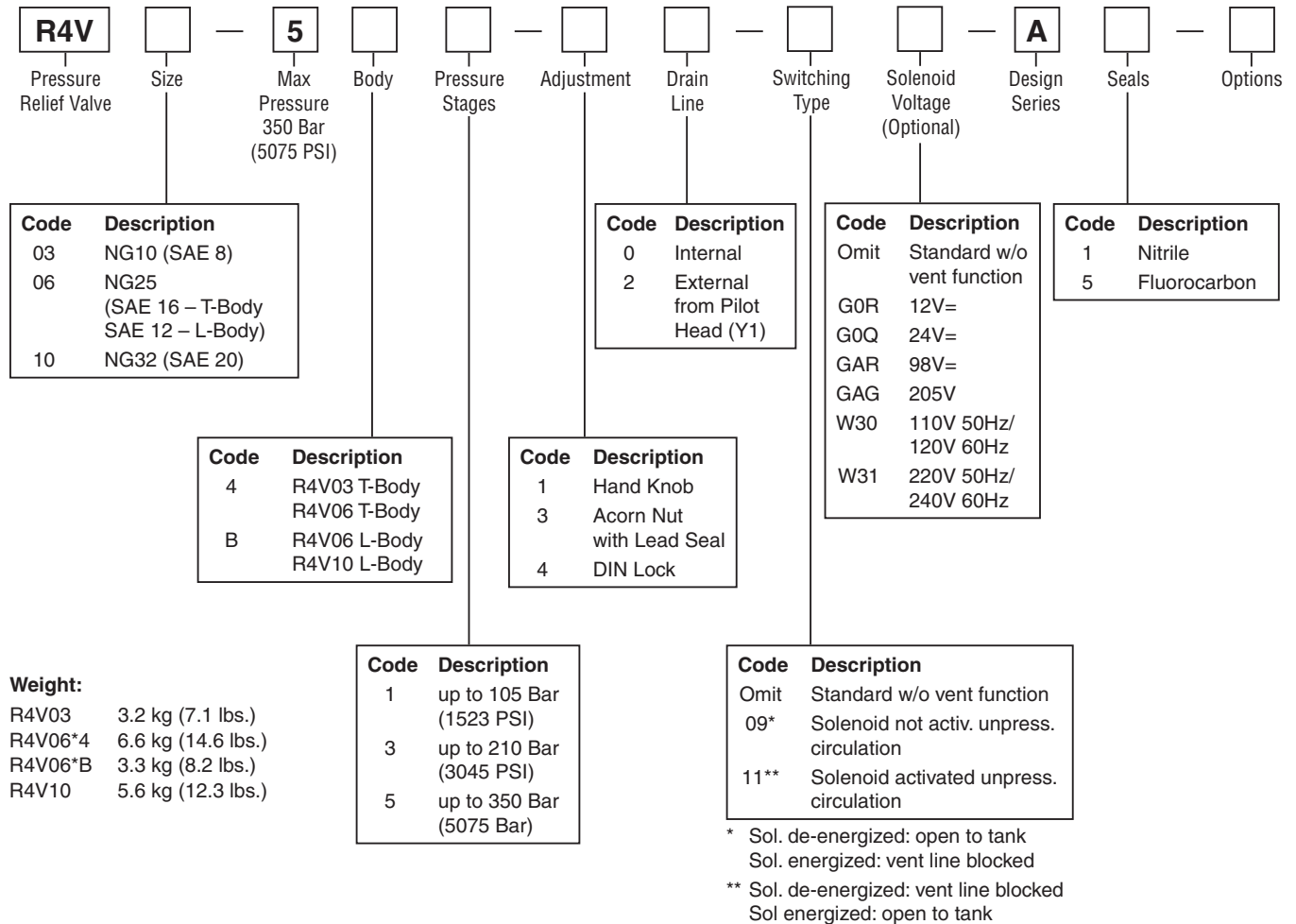

**Performance Curves\***

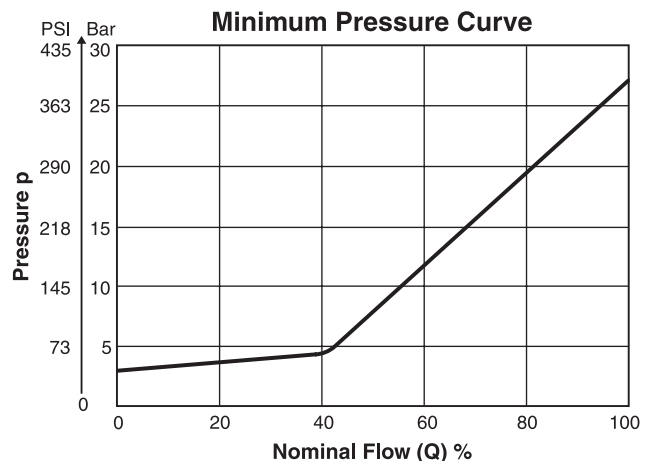
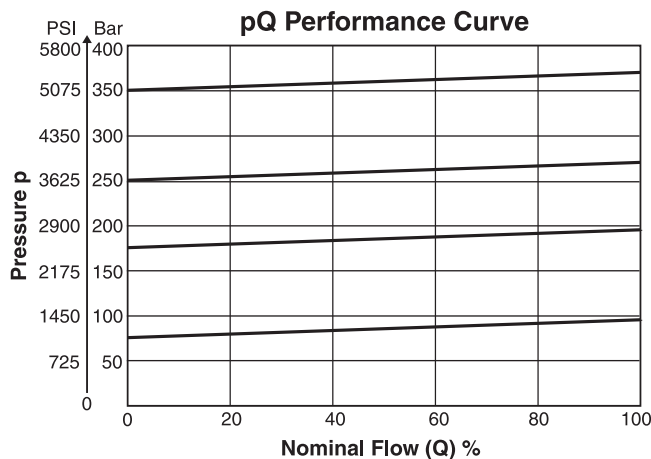

\* The performance curves are measured with external drain. For internal drain, the tank pressure has to be added to the curve.

**T-Body**

Inch equivalents for millimeter dimensions are shown in (\*\*)

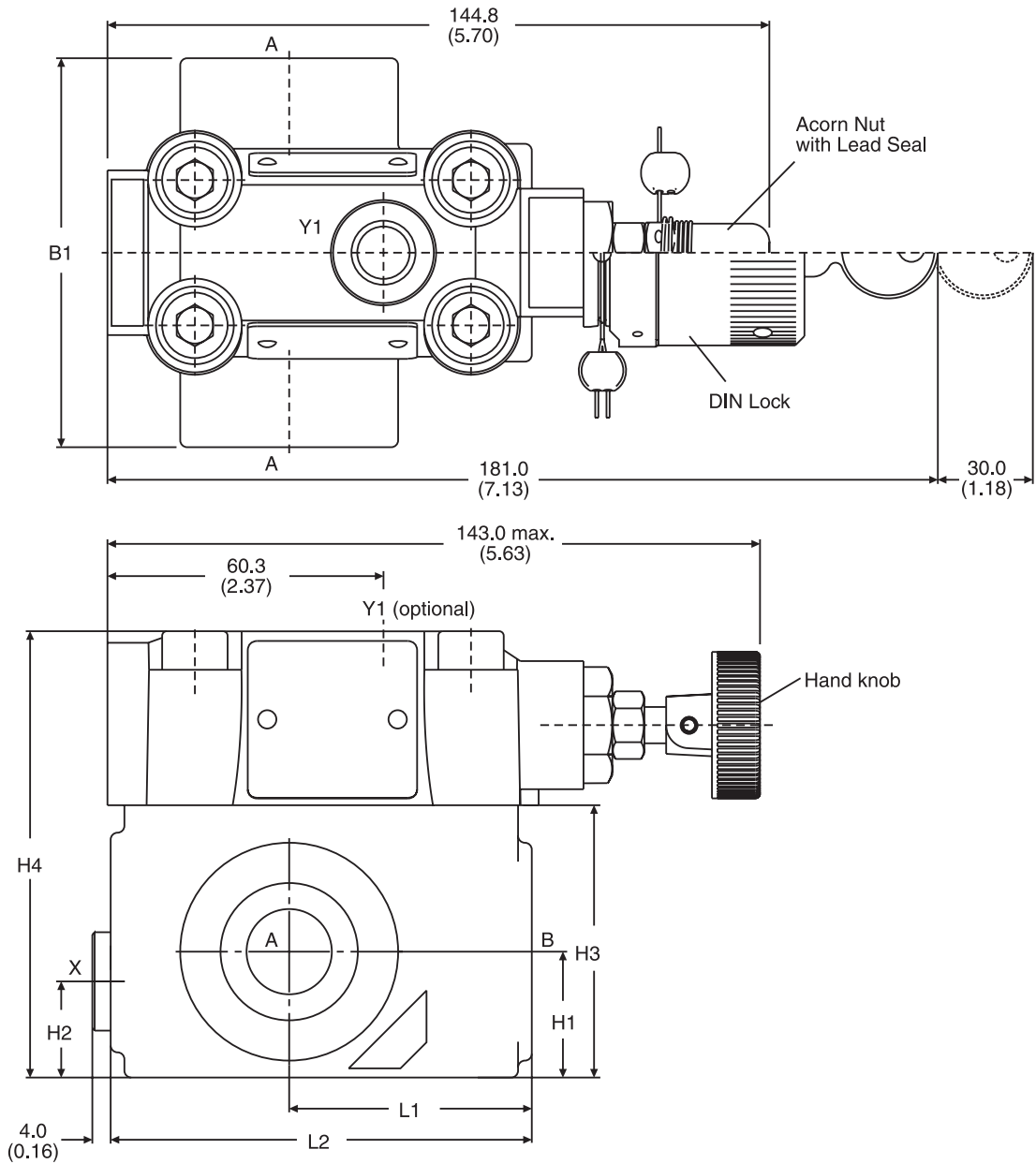

Size	Body	B1	B2	B3	B4	H1	H2	H3	H4	H5	H6	H7	H8	L1	L2	L3
03	T-body	85.0 (3.35)	-	-	-	27.5 (1.08)	21.0 (0.83)	59.5 (2.34)	97.5 (3.84)	-	-	-	-	53.0 (2.09)	92.0 (3.62)	-
06	T-body	136.0 (5.35)	-	-	-	38.0 (1.50)	28.0 (1.10)	93.0 (3.66)	131.0 (5.16)	-	-	-	-	66.5 (2.62)	117.5 (4.63)	-

Ports	Function	Port size	
		R4V03 T-body	R4V06 T-body
A	Pressure (inlet)	SAE 8	SAE 16
B	Tank (outlet)	SAE 8	SAE 16
X <sup>1)</sup>	Ext. Remote Control or Vent Connection	SAE 4	
Y1 <sup>2)</sup>	External Drain		

<sup>1)</sup> closed when supplied

<sup>2)</sup> port Y1 is only available at drain line (code 2) external from the pilot head

**L-Body**

Inch equivalents for millimeter dimensions are shown in (\*\*)

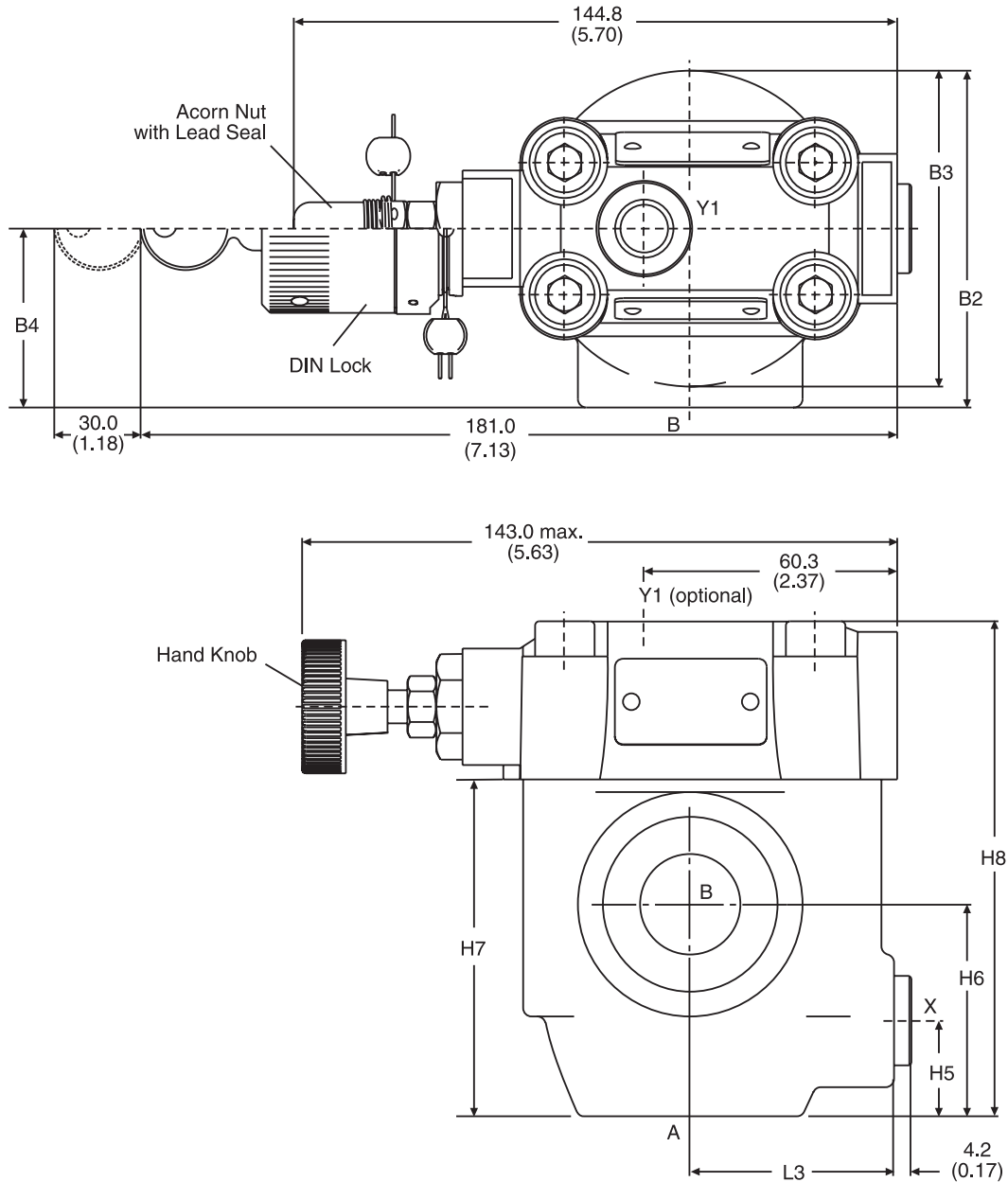

Size	Body	B1	B2	B3	B4	H1	H2	H3	H4	H5	H6	H7	H8	L1	L2	L3
06	L-body	-	81.0 (3.19)	76.0 (2.99)	43.0 (1.69)	-	-	-	-	23.0 (0.91)	51.0 (2.01)	81.0 (3.19)	119.0 (4.69)	-	-	49.0 (1.93)
10	L-body	-	120.7 (4.75)	85.8 (3.38)	77.8 (3.06)	-	-	-	-	31.8 (1.25)	50.8 (2.00)	96.0 (3.78)	134.0 (5.78)	-	-	49.8 (1.96)

Ports	Function	Port size	
		R4V06 L-body	R4V10 L-body
A	Pressure (inlet)	SAE 12	SAE 20
B	Tank (outlet)	SAE 12	SAE 20
X <sup>1)</sup>	Ext. Remote Control or Vent Connection	SAE 4	
Y1 <sup>2)</sup>	External Drain	SAE 4	

<sup>1)</sup> closed when supplied

<sup>2)</sup> port Y1 is only available at drain line (code 2) external from the pilot head

**R4V with Vent Function**

Inch equivalents for millimeter dimensions are shown in (\*\*)

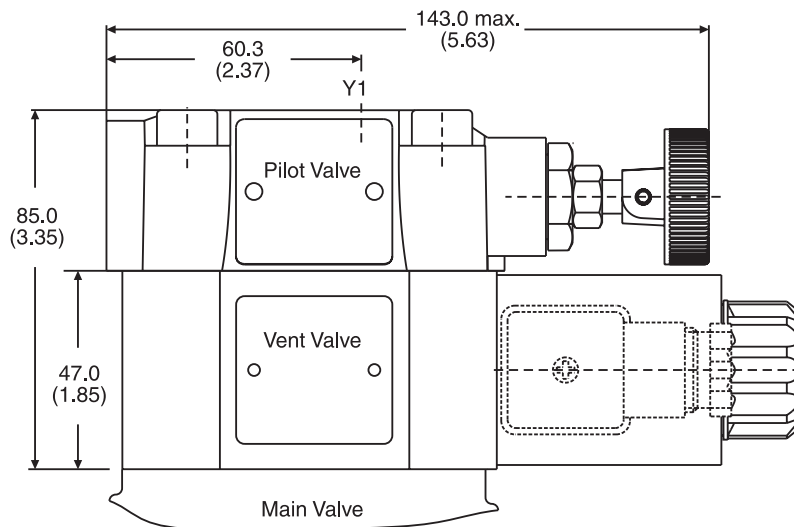
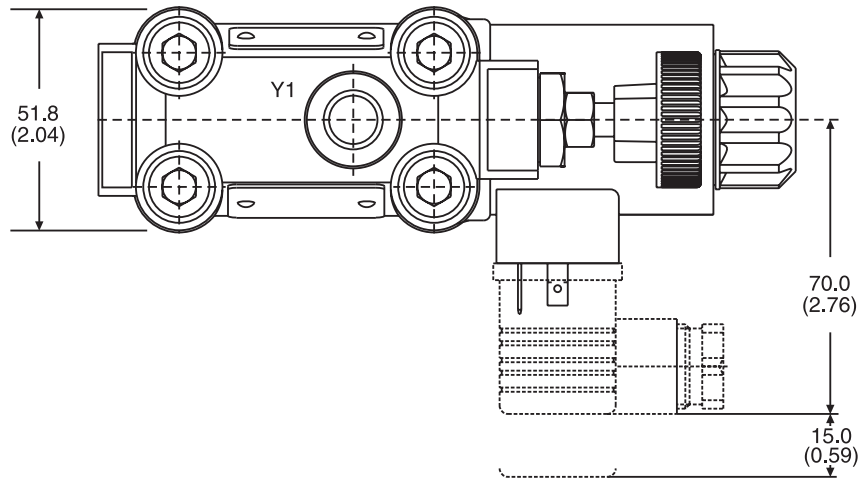

Code	Internal Drain	External Drain
11		
09		

R4V.indd, dd

### General Description

Series R6701 relief valves are pilot operated relief valves. When system pressure reaches the selected adjustable setting on this valve, the valve opens the system to tank.

### Features

- Accurate, quick response due to pressure balanced spool design.
- Available in 1/4" through 3/4" sizes.
- Can be equipped with Tel-lok cap for tamper-proof design (1/4" - 3/4" sizes only).
- High volume pilot operated relief 340.7 LPM (90 GPM)  
 1 1/4" and 1 1/2" poppet design available.

### Specifications

<b>Service Applications</b>	Hydraulic Oil
<b>Pressure Adjustment Ranges</b>	Range 1: Sizes 1/4" - 3/4" 13.8 - 82.8 Bar (200 - 1200 PSI) Sizes 1 1/4" - 1 1/2" 17.3 - 82.8 Bar (200 - 1200 PSI) Range 2: Sizes 1/4" - 3/4" 69 - 207 Bar (1000 - 3000 PSI) Sizes 1 1/4" - 1 1/2" 69 - 207 Bar (1000 - 3000 PSI) Range 3: Sizes 1/4" - 3/4" 207 - 414 Bar (3000 - 6000 PSI) Sizes 1 1/4" - 1 1/2" 207 - 414 Bar (3000 - 6000 PSI)
<b>Sizes</b>	NPT 1/4", 1/2", 3/4"
<b>Ports</b>	NPT Pipe threads
<b>Mounting</b>	In-line or panel
<b>Material</b>	Body, Cap, Piston Sleeve, Pilot Cap Barstock steel Pilot Knob Aluminum Piston, Adjustable Stem, Pilot Piston, Pilot Seat 400 Stainless Steel O-rings Synthetic rubber Back-up Rings PTFE Body Finish Paint
<b>Operating Temperature</b>	-40°C to +121°C (-40°F to +250°F)

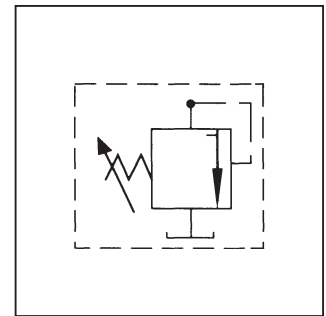
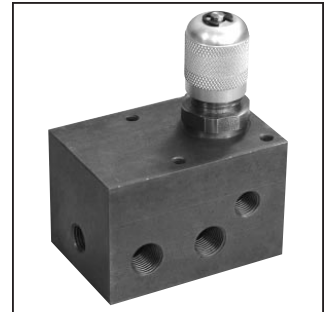
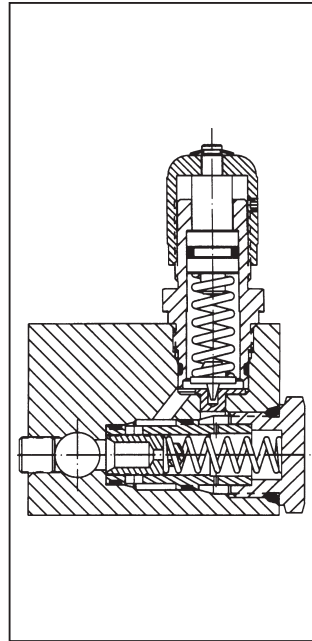

### Flow Data

Valve Size	Cv Factor Inlet to Inlet	Flow Rate GPM Max.	Vent Pressure at Max. Flow	Weight
1/4	1.5	6	65 PSI	4 Lbs. 12 Oz.
1/2	9.0	15	30 PSI	7 Lbs.
3/4	12.5	25	50 PSI	9 Lbs. 10 Oz.



**Ordering Information**

<b>X</b>	<b>R</b>	<b>670</b>	<b>1</b>	<b>-1</b>	<b>-1/4</b>	<b>S</b>	<b>2</b>
<b>Option</b>	<b>Type Valve</b>	<b>Catalog Number</b>	<b>Port Position</b>	<b>Pressure Range</b>	<b>Size</b>	<b>Materials</b>	<b>O-Ring Code</b>
X External Drain	R Relief	670 Tel-Trol Pilot-Operated Relief Valve	1 Inline	1 (Sizes $\frac{1}{4}$ - $\frac{3}{4}$ ) 200 to 1200 PSI  2 (Sizes $\frac{1}{4}$ - $\frac{3}{4}$ ) 1000 to 3000 PSI  3 (Sizes $\frac{1}{4}$ - $\frac{3}{4}$ ) 3000 to 6000 PSI	1/4 NPT 1/2 NPT 3/4 NPT	S Steel	2 Nitrile Others Available

**Dimensions** — Shown in inches



**R6701 Sizes 1/4 – 3/4**

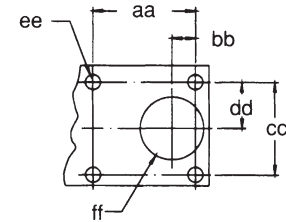
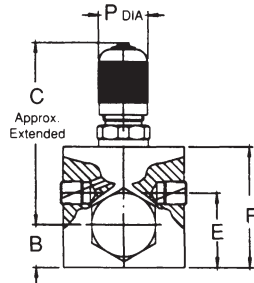

**Panel Machining for Panel Mounted Valves**

**Panel Mounting Dimensions**

Valve Size	aa	bb	cc	dd	ee	ff	Mounting Threads
$\frac{1}{4}$	1.750	0.531	1.750	0.875	0.281	1.4375	$\frac{1}{4}$ - 20NC-2
$\frac{1}{2}$							
$\frac{3}{4}$	2.312	0.531	2.125	1.062	0.343	1.4375	$\frac{5}{16}$ -18NC-2

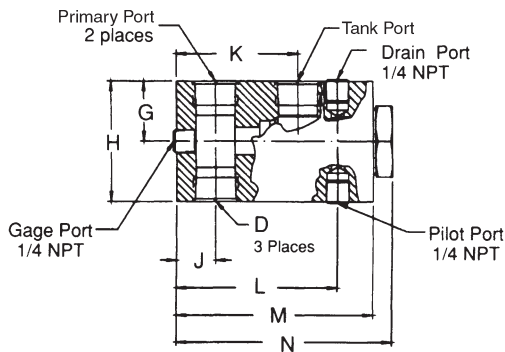

Valve Size	A	B	C	Port Type D	E	F	G	H	J	K	L	M	N	P
$\frac{1}{4}$	2.313	.750	4.000	$\frac{1}{4}$ NPT	1.313	2.375	1.187	2.375	.625	1.563	2.313	3.125	3.437	1.125
$\frac{1}{2}$	3.188	.968	4.156	$\frac{1}{2}$ NPT	1.688	2.750	1.125	2.250	.750	2.250	3.188	4.000	4.437	1.125
$\frac{3}{4}$	3.688	.968	4.156	$\frac{3}{4}$ NPT	1.688	2.750	1.375	2.750	.891	2.781	3.688	4.500	4.937	1.125

### General Description

Series 620 - 649 in-line pressure control valves open the system to tank when the system pressure reaches the pressure setting of the control valve. The pressure setting is externally adjustable so that it can be tuned accordingly within its range. However, the valve can be factory set to a specified pressure setting.

### Specifications

<b>Service App.</b>	Hydraulic and Pneumatic
<b>Maximum Operating Pressure</b>	Working: 0.3 to 248.4 Bar (4 to 3600 PSI) in 13 ranges Reset: Range 1: 80% of cracking press. Ranges 2 - 13: 90% of cracking pressure
<b>Sizes</b>	NPT 1/4", 1/2", 3/4" IST SAE 6, SAE 10, SAE 12 FLD SAE 6, SAE 10, SAE 12
<b>Ports</b>	NPT Pipe threads IST Internal straight threads FLD Flared Tube Connection SAE 37°
<b>Material</b>	Body, Cap Brass, aluminum alloy, stainless steel Finish Aluminum alloy, anodized; stainless steel Poppet 416 Stainless Steel (Hard seat) 303 Stainless Steel (Soft seat) Seat (soft) Ranges 1 -3: Synthetic rubber - Code 2 Ranges 4 - 13: PTFE Spring Stainless steel Cap O-ring Synthetic rubber
<b>Operating Temperature</b>	-40°C to +121°C (-40°F to +250°F) Higher on special order

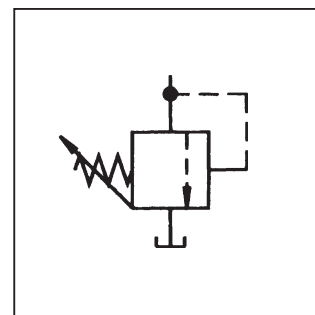
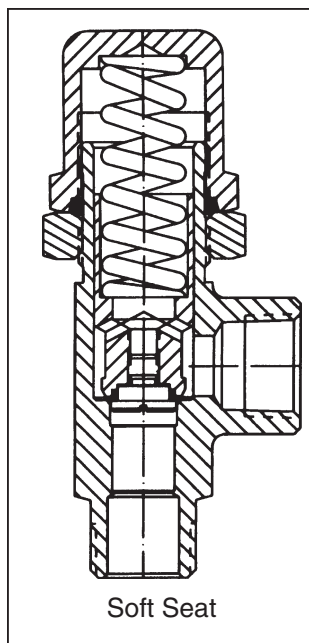

Hard Seat  
 available only in  
 Brass and Stainless Steel

### Features

- Externally adjustable.
- Available for hydraulic or pneumatic service.
- Quick response for venting applications.

### Dimensions

Inch equivalents for millimeter dimensions are shown in (\*\*)

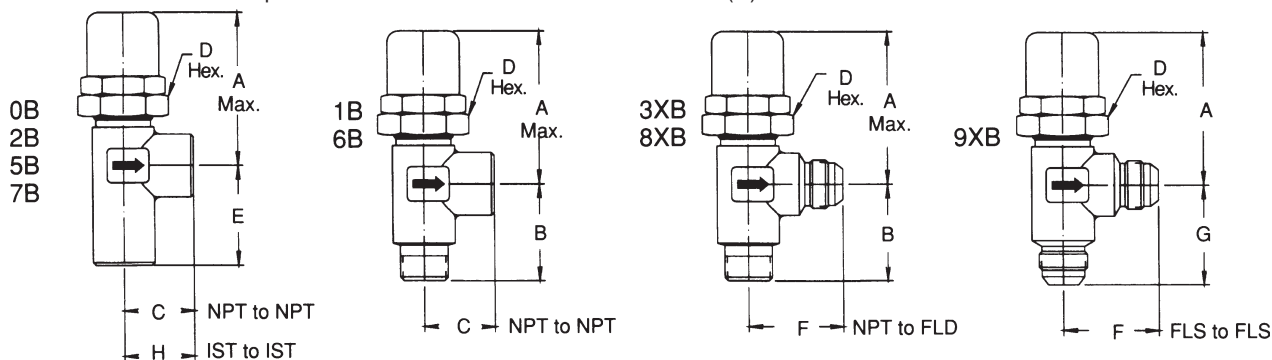

Valve Size		Dimensions								Maximum Rated Flow LPM (GPM)	Weights (Approx.)		
Pipe	Tube	A	B	C	D	E	F	G	H		Allum. Alloy	Brass	Stainless Steel
1/4	6	60.3 (2.38)	34.9 (1.38)	27.0 (1.06)	31.8 (1.25)	32.5 (1.28)	36.5 (1.44)	38.1 (1.50)	27.0 (1.06)	15.1 (4.0)	4 oz.	10 oz.	12 oz.
1/2	10	94.5 (3.72)	54.0 (2.13)	38.1 (1.50)	44.5 (1.75)	54.8 (2.16)	52.4 (2.06)	55.6 (2.19)	38.1 (1.50)	37.9 (10.0)	14 oz.	2 lbs. 2 oz.	2 lbs. 4 oz.
3/4	12	94.5 (3.72)	54.0 (2.13)	39.7 (1.56)	44.5 (1.75)	55.6 (2.19)	53.2 (2.09)	55.6 (2.19)	39.7 (1.56)	56.8 (15.0)	14 oz.	2 lbs. 2 oz.	2 lbs. 4 oz.

620-649.indd, dd

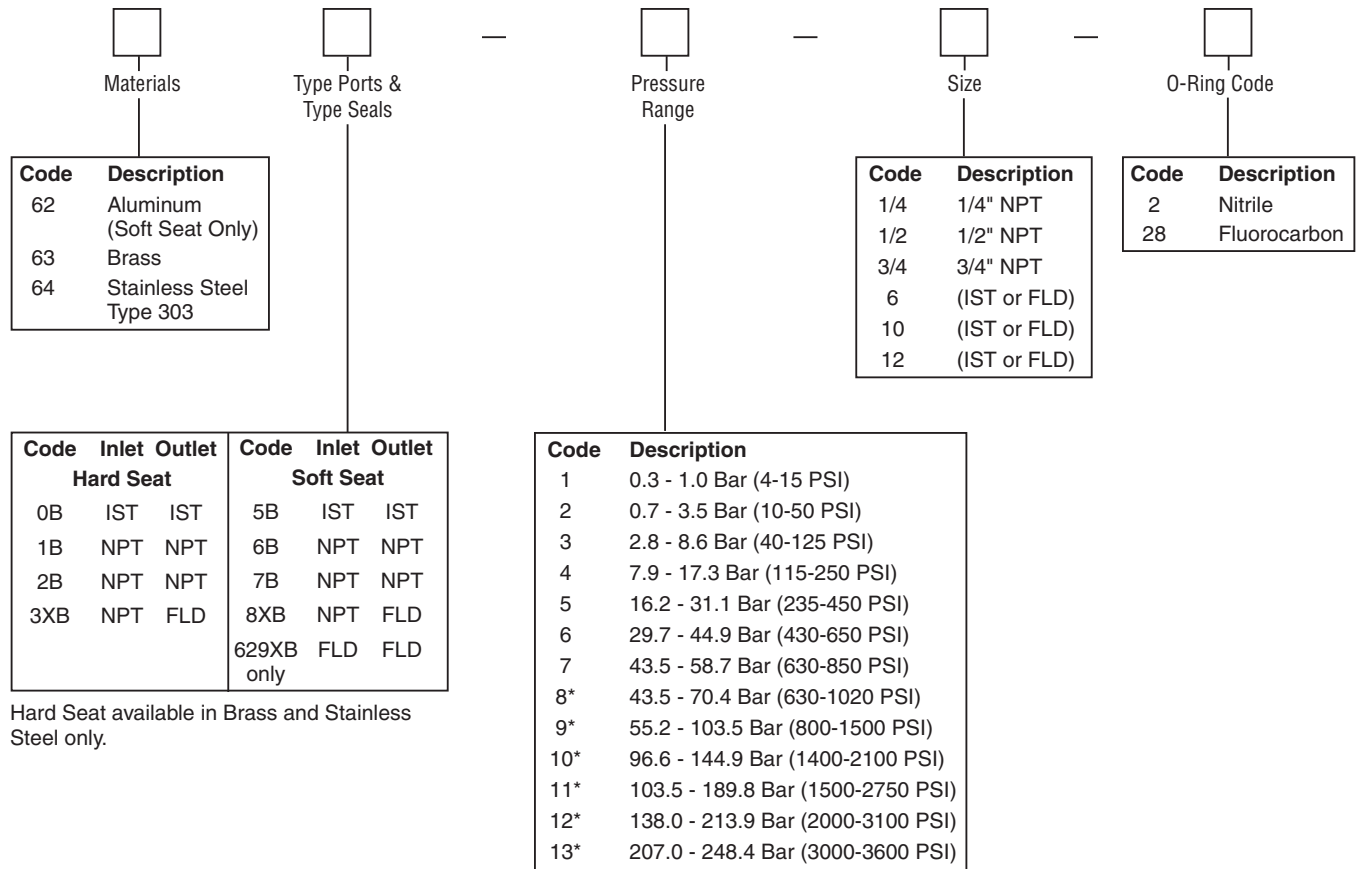

\* Hard Seat only.  
 PTFE seats for Ranges 4, 5, 6 and 7 only.

**Pressure Range**

Range Bar (PSI)	Pre-Set Cracking Pressure	Soft Seat Material (when used)	Range Dash Number
0.3 - 1.0 Bar (4-15 PSI)	0.7 Bar (10 PSI)	Synthetic Rubber	-1
0.7 - 3.5 Bar (10-50 PSI)	2.4 Bar (35 PSI)	Synthetic Rubber	-2
2.8 - 3.5 Bar (40-125 PSI)	6.2 Bar (90 PSI)	Synthetic Rubber	-3
7.9 - 17.3 Bar (115-250 PSI)	13.8 Bar (200 PSI)	PTFE	-4
16.2 - 31.1 Bar (235-450 PSI)	24.8 Bar (360 PSI)	PTFE	-5
29.7 - 44.9 Bar (430-650 PSI)	38.0 Bar (550 PSI)	PTFE	-6
43.5 - 58.7 Bar (630-850 PSI)	51.8 Bar (750 PSI)	PTFE	-7
43.5 - 70.4 Bar (630-1020 PSI)	58.7 Bar (850 PSI)	PTFE	-8
55.2 - 103.5 Bar (800-1500 PSI)	69.0 Bar (1000 PSI)	PTFE	-9
96.6 - 144.9 Bar (1400-2100 PSI)	120.8 Bar (1750 PSI)	PTFE	-10
103.5 - 189.8 Bar (1500-2750 PSI)	151.8 Bar (2200 PSI)	PTFE	-11
138.0 - 213.9 Bar (2000-3100 PSI)	179.4 Bar (2600 PSI)	PTFE	-12
207.0 - 248.4 Bar (3000-3600 PSI)	220.8 Bar (3200 PSI)	PTFE	-13

**Definitions:**

Cracking pressure – Liquid: 15 tp 20 DPM  
 Air: steady stream of bubbles  
 Reseat leakage – Less than 1 DPM or 1 BPM

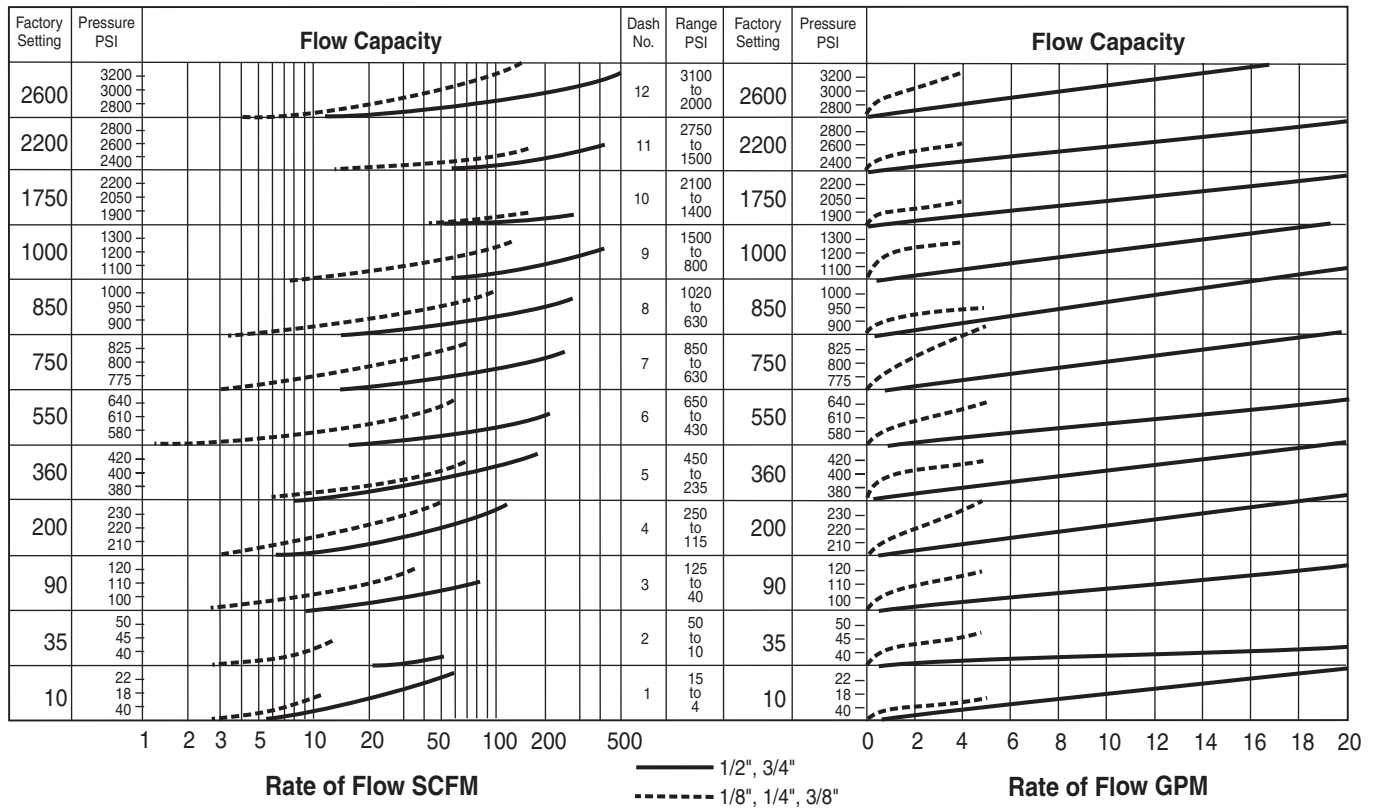

**Examples**

**Pneumatic:**

Establish cracking pressure setting of 1/2" valve for flow of 70 SCFM at 27.6 Bar (400 PSI) pressure:

1. Project 70 SCFM on vertical scale.
2. Project 27.6 Bar (400 PSI) scale horizontally intersection 1.
3. Project line parallel to curves back to vertical line 1.
4. Read cracking pressure setting: 24.8 Bar (360 PSI).

**Hydraulic:**

Find amount of pressure increase above 24.8 Bar (360 PSI) cracking pressure when flow through 3/4" valve is increased to 54 LPM (14 GPM):

1. From 360 on vertical pressure scale, follow 3/4" curve until it intersects with the vertical line representing 54 LPM (14 GPM).
2. Project intersecting point horizontally and read pressure, i.e., 29 Bar (420 PSI).
3. Accumulated Pressure:  
 $420 \text{ minus } 360 = 4.1 \text{ Bar (60 PSI)}$ .

**General Description**

Series 665 relief valves are adjustable, in-line direct-acting relief valves. The valve opens when the system pressure exceeds the pressure at which the valve is set.

**Specifications**

<b>Service App.</b>	Hard seat: Hydraulic Soft seat: Hydraulic and air
<b>Maximum Operating Pressure</b>	Working: 0.3 to 248.4 Bar (4 to 3600 PSI) in 13 ranges Reseat: Range 1: 80% of cracking press. Ranges 2 - 13: 90% of cracking pressure Proof: 310.5 Bar (4500 PSI)
<b>Sizes</b>	NPT 1/4", 1/2", 3/4", 1"
<b>Ports</b>	NPT Pipe threads IST Internal straight threads
<b>Material</b>	Body, Cap Aluminum alloy, anodized Stainless steel Poppet, 416 Stainless Steel (Hard seat) Adj. Screw 303 Stainless Steel (Soft seat) Locknut 303 Stainless steel Spring Stainless steel AMS5688 and 17-7PH O-ring Synthetic rubber Seat (soft) Ranges 1-3: Synthetic rubber Ranges 4-13: PTFE
<b>Operating Temperature</b>	-40°C to +121°C (-40°F to +250°F) Higher on special order

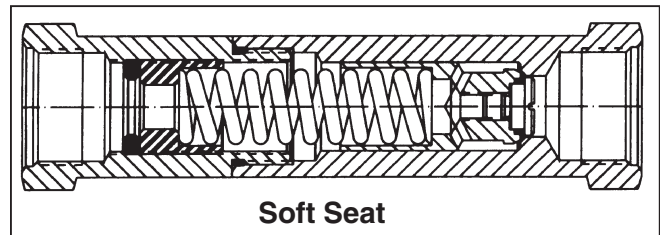
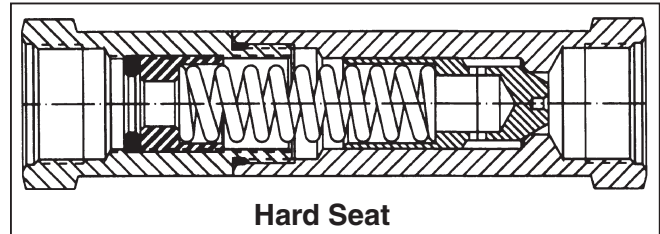
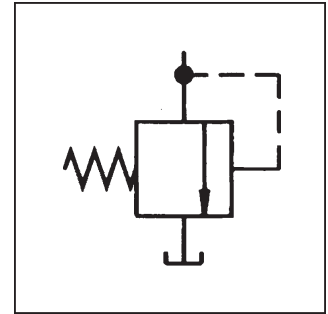

**Features**

- Internal adjustment ideal for tamper-proof applications.
- Available for hydraulic or pneumatic service.
- In-line design saves space in power unit application.

**Ordering Information**

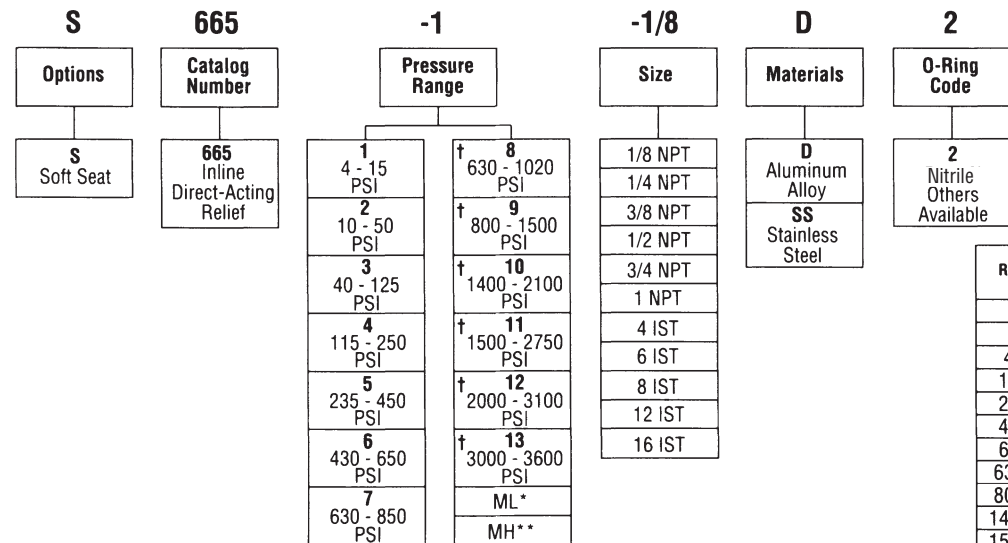

**Pressure Range**

Range PSI	Pre-Set Cracking Pressure	Soft Seat Material (when used)	Range Dash Number
4-15	10	Synthetic Rubber	-1
10-50	35		-2
40-125	90		-3
115-250	200	PTFE	-4
235-450	360		-5
430-650	550		-6
630-850	750		-7
630-1020	850		-8
800-1500	1000		-9
1400-2100	1750		-10
1500-2750	2200		-11
2000-3100	2600		-12
3000 - 3600	3200		-13

† **NOTE:** Ranges 8 and above – Hard Seat only  
 Teflon seats for Ranges 4, 5, 6 and 7 only

Definitions:  
 Cracking pressure – Liquid: 15 to 20 DPM  
 Air: steady stream of bubbles  
 Reseat leakage – Less than 1 DPM or 1 BPM

**Performance Curves**

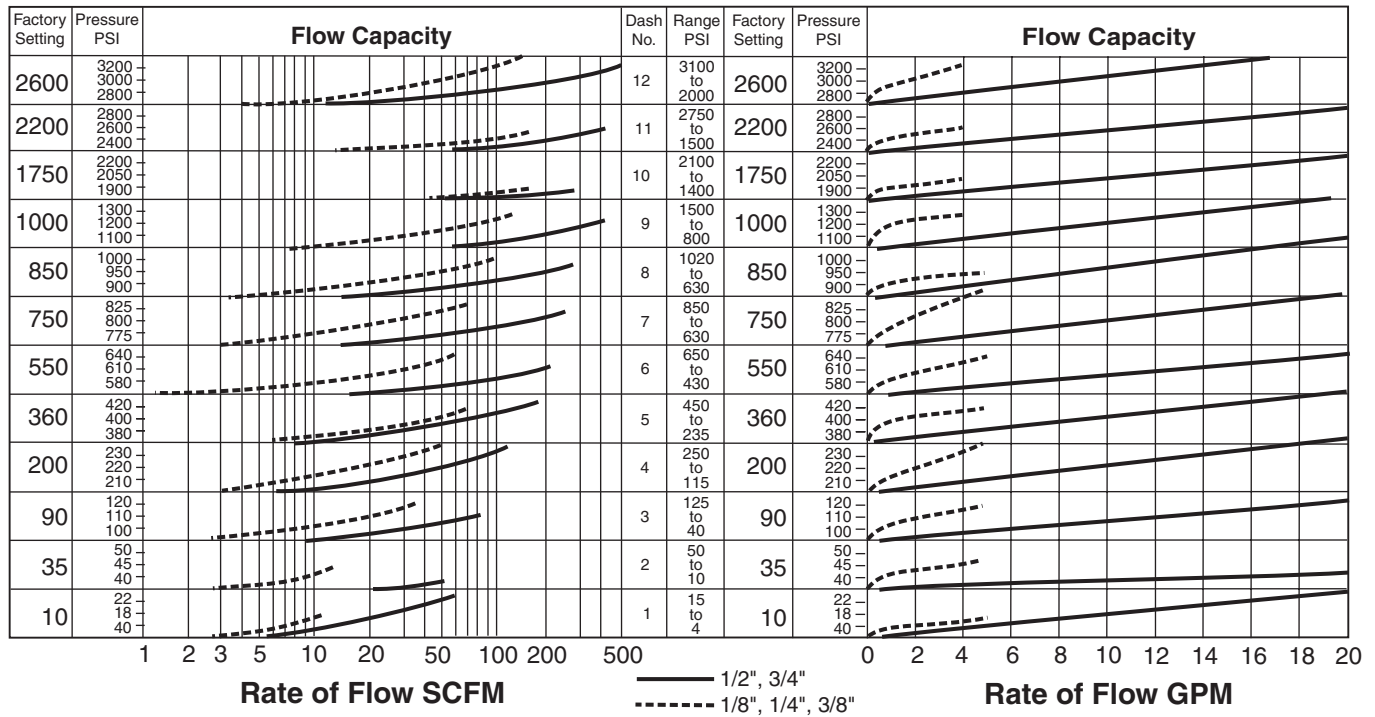

**Examples**

**Pneumatic:**

Establish cracking pressure setting of 1/2" valve for flow of 70 SCFM at 27.6 Bar (400 PSI) pressure:

1. Project 70 SCFM on vertical scale.
2. Project 27.6 Bar (400 PSI) scale horizontally intersectioning 1.
3. Project line parallel to curves back to vertical line 1.
4. Read cracking pressure setting: 24.8 Bar (360 PSI).

**Hydraulic:**

Find amount of pressure increase above 24.8 Bar (360 PSI) cracking pressure when flow through 3/4" valve is increased to 54 LPM (14 GPM):

1. From 360 on vertical pressure scale, follow 3/4" curve until it intersects with the vertical line representing 54 LPM (14 GPM).
2. Project intersecting point horizontally and read pressure, i.e., 29 Bar (420 PSI).
3. Accumulated Pressure: 420 minus 360 = 4.1 Bar (60 PSI).

**Dimensions – Shown in inches**

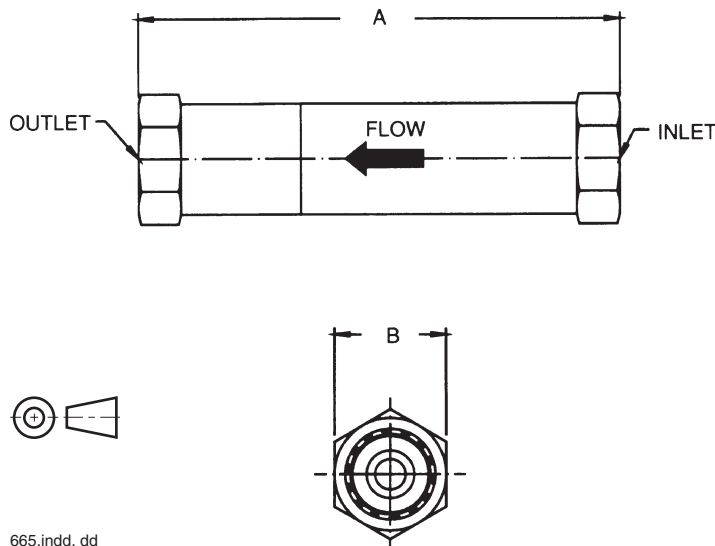

Valve Size NPT	A	B	Maximum Rated Flow G.P.M.	Weights (Approx.)	
				Aluminum Alloy	Stainless Steel
1/4	5	1 3/16	4	0.6 Lbs.	1.3 Lbs.
1/2	5	1 3/16	10		
3/4	7	1 5/8	15	1.7 Lbs.	3.2 Lbs.
1	7	1 5/8	15		

**General Description**

Series RCP in-line pressure control valves are chiefly used as remote control valves. They limit system pressure by opening to tank when pressure reaches the selected relief pressure.

When used as remote control valves, Series RCP valves are piped to the vent port of a pilot operated relief valve, such as Series RP and RM valves.

Pressure relief settings are made with a self-locking knob that is pulled and turned to the proper setting. Pushing the knob in locks it positively at this setting.

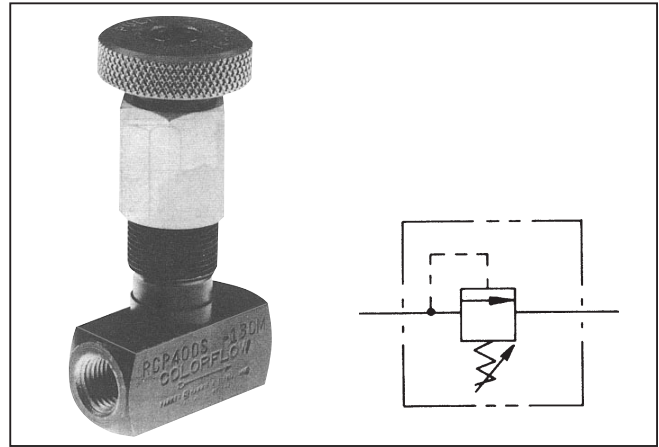

**Specifications**

<b>Pressure Adjustment Ranges</b>	3 - 70 Bar (50 - 100 PSI) 10 - 140 Bar (150 - 2000 PSI) 10 - 210 Bar (150 - 3000 PSI)
<b>Maximum Operating Pressure</b>	210 Bar (3000 PSI)
<b>Flow</b>	4 LPM (1 GPM) Maximum 492 cc./min.(30 Cu. In./min.) Minimum
<b>Pressure Setting</b>	3.4 Bar (50 PSI) Minimum, at maximum flow Changes in flow, viscosity or temperature will affect minimum pressure
<b>Size</b>	1/4"
<b>Port</b>	NPTF
<b>Mounting</b>	Any position, panel mounting kit available

**Ordering Information**

Example: "RCP400SF" means Series RCP, 1/4", steel, 150—2000 PSI pressure adjustment range, standard nitrile seal.

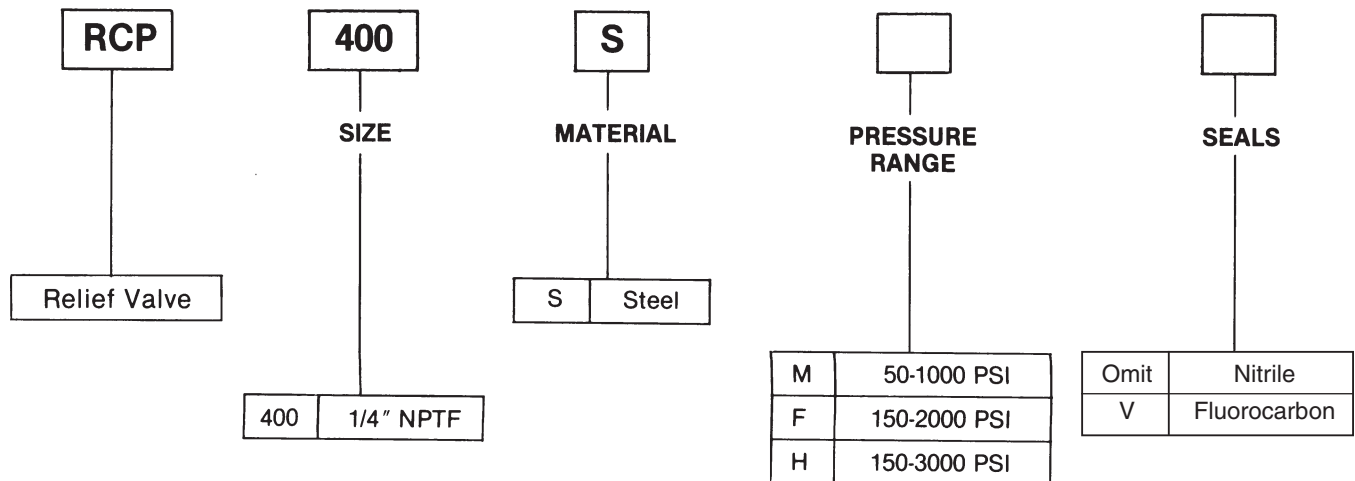



Millimeter equivalents for inch dimensions are shown in (\*\*)

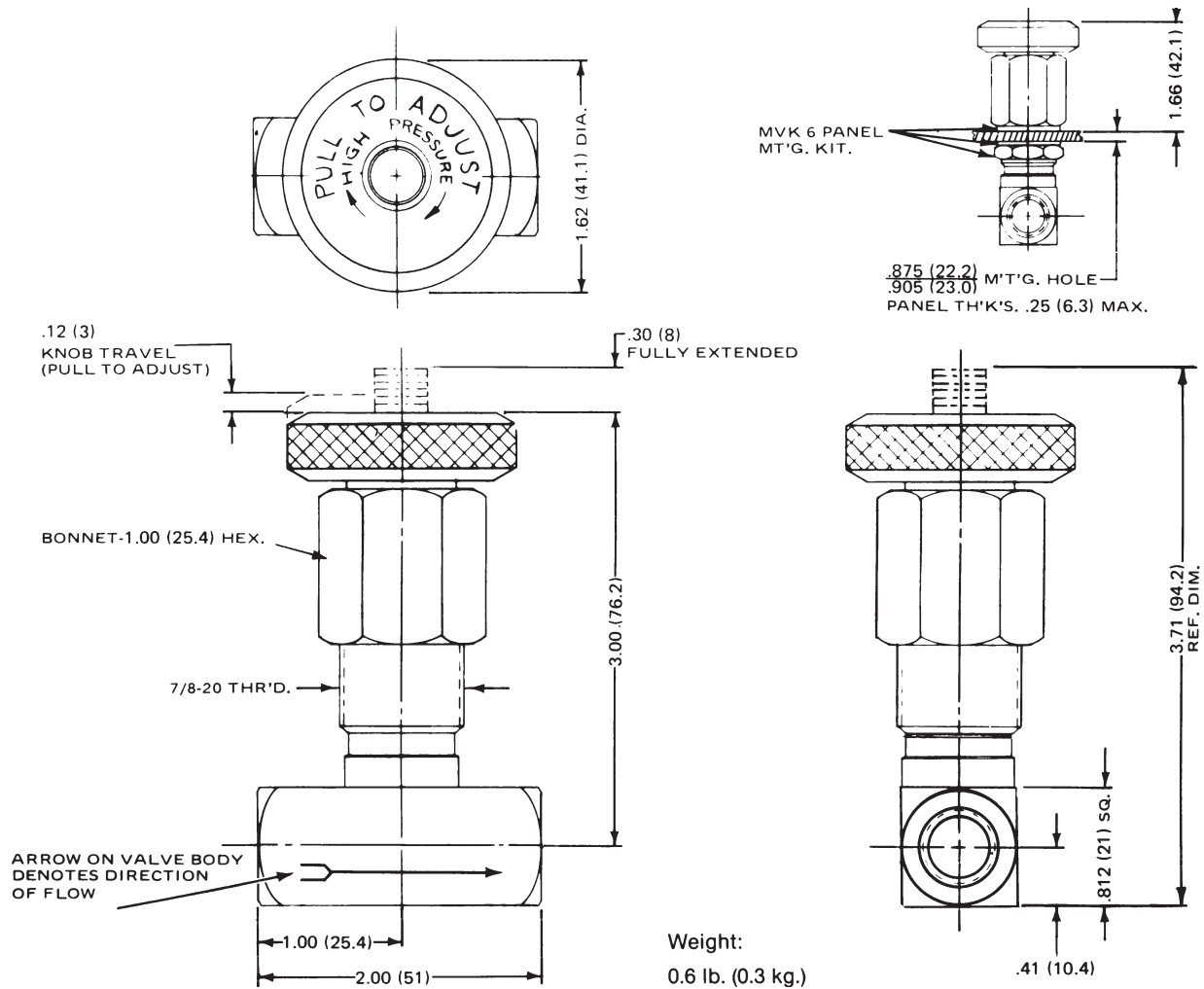



**General Description**

Series RP pressure control valves open the system to tank when the system pressure reaches the pressure setting of the control valve (see pressure adjustment ranges, below).

By adding a remote pilot valve to the vent port of a main pilot relief valve, pressure can be controlled by remote control. With this arrangement, the main relief valve setting should be 10 Bar (150 PSI) higher than the remote pilot setting.

For venting flow at minimum pressure, the vent port of the main relief valve can be connected directly to the tank.

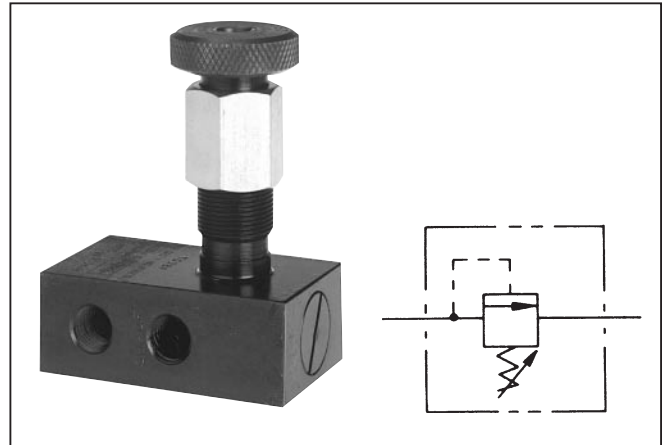

**Specifications**

<b>Pressure Adjustment Ranges</b>	3 - 70 Bar (50 - 100 PSI) 10 - 140 Bar (150 - 2000 PSI) 10 - 210 Bar (150 - 3000 PSI)
<b>Maximum Operating Pressure</b>	210 Bar (3000 PSI)
<b>Override</b>	Any relief valve is subject to override, or a change in relief pressure when a change in flow occurs. For override characteristics, see chart on next page.

**Flow Data**

Valve Model	Port Size	Flow, max. GPM (L/M)	Vent Pressure PSI (Bar)
RP400	1/4 NPTF	6 (25)	60 (4)
RP600	3/8 NPTF	10 (40)	80 (5)
RP800	1/2 NPTF	15 (60)	50 (3)

**Ordering Information**

Example: "RP400SFV" means Series RP relief valve, 1/4" size, steel, 150-2000 PSI pressure range, optional Fluorocarbon seal.

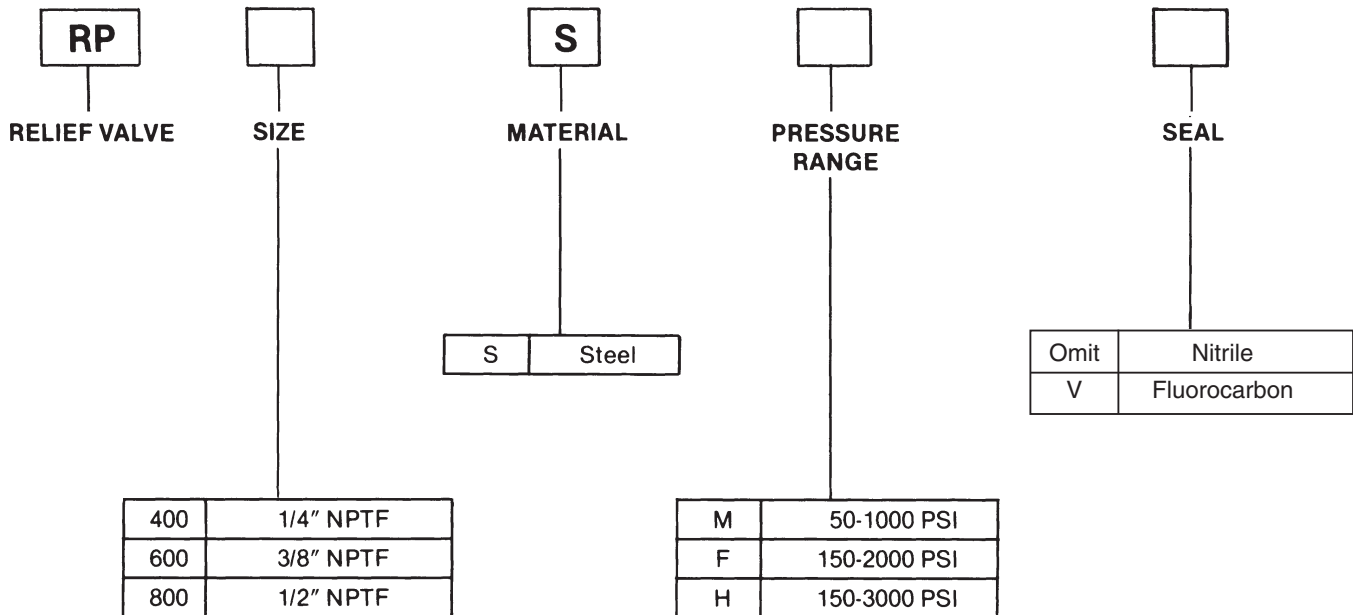

### Override Specifications

All relief valves are subject to override. For a given valve setting and flow, any changes in flow will cause a change in relief pressure. For example, a valve set at 140 Bar (2000 PSI) at 25% flow will read 145 Bar (2100 PSI) at 100% flow.

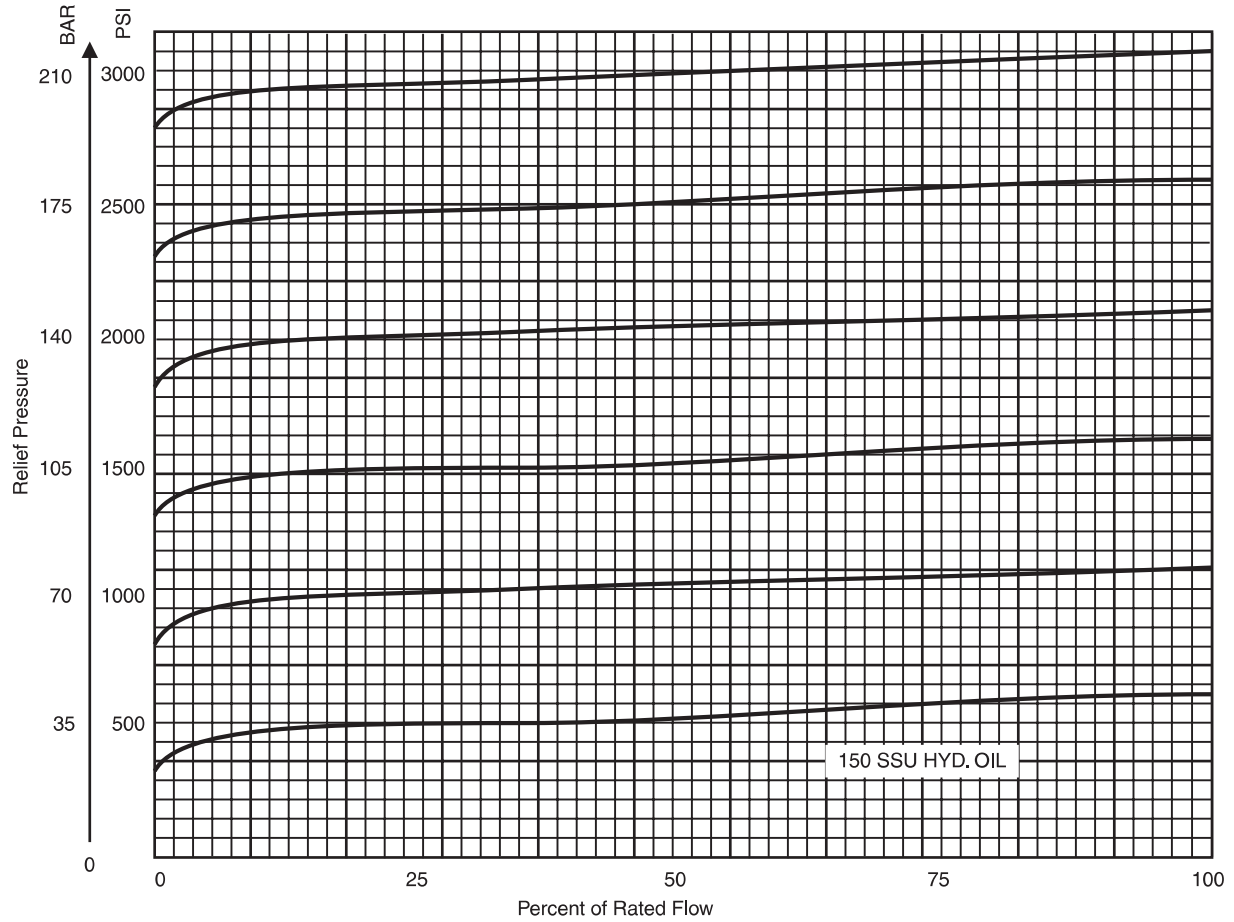

Relief Pressure vs. Flow

Millimeter equivalents for inch dimensions are shown in (\*\*)

In-line mounted, pilot operated  
Pressure Relief Valves

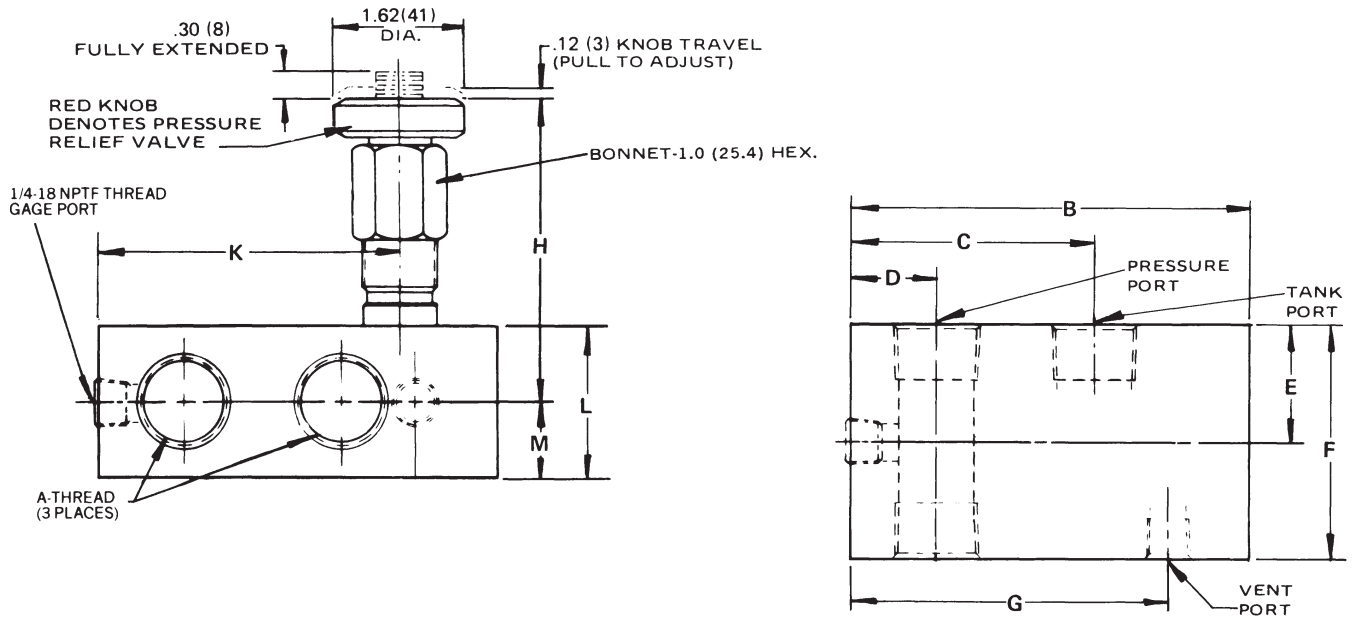

Valve Size	A-Thread	B	C	D	E	F	G	H	J	K	L	M	Weight Lb. (Kg)
RP400S	1/4-18 NPTF	3.00 (76.2)	1.60 (41.0)	0.67 (17.0)	0.88 (22.3)	1.75 (44.4)	2.25 (57.1)	3.16 (80.2)	4.02 (102.1)	2.04 (52.0)	1.12 (28.4)	0.56 (14.2)	1.9 (0.8)
RP600S	3/8-18 NPTF	3.53 (90.0)	2.00 (51.0)	0.75 (19.0)	1.00 (25.4)	2.00 (51.0)	2.77 (70.3)	3.22 (82.0)	4.14 (105.1)	2.62 (66.5)	1.25 (32.0)	0.62 (16.0)	2.6 (1.2)
RP800S	1/2-14 NPTF	4.10 (104.1)	2.40 (61.0)	0.91 (23.1)	1.12 (28.4)	2.25 (57.1)	3.17 (81.0)	3.34 (85.0)	4.39 (115.0)	3.03 (77.0)	1.50 (38.1)	0.75 (19.0)	3.7 (1.7)

**General Description**

Series P6701 valves serve as a remote pilot for a pilot operated parent valve. Adjustable in three pressure ranges: 6.9 to 82.8 Bar (100 to 1200 PSI), 69 to 207 Bar (1000 to 3000 PSI) and 207 to 345 Bar (3000 to 6000 PSI).

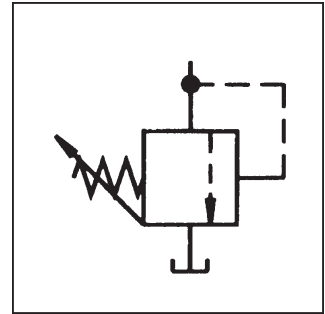
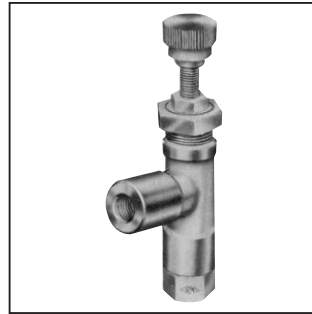

**Features**

- Remote pilot for R6701, R6703, S6701, S6703, PR6701 and PR6703.
- Ideal for adjustable vent valve.

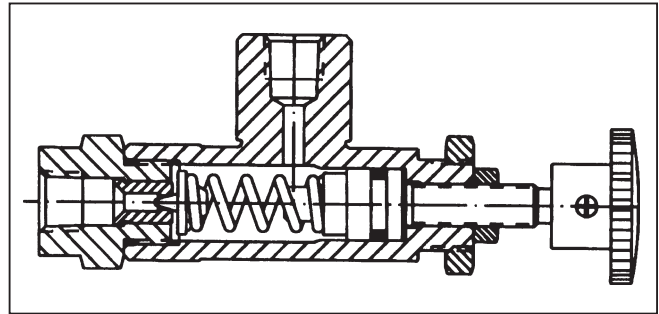

**Specifications**

<b>Service App.</b>	Hydraulic Oil	<b>Internal Leakage</b>	Less than 1 DPM at 90% of cracking pressure
<b>Pressure Adjustment Range</b>	Range 1: 6.9 - 82.8 Bar (100 - 1200 PSI) Range 2: 69 - 207 Bar (1000 - 3000 PSI) Range 3: 207 - 414 Bar (3000 - 6000 PSI)	<b>Mounting</b>	Panel hole 27/32" diameter
<b>Maximum Operating Pressure</b>	Proof: 517.5 Bar (7500 PSI) Burst: 828 Bar (12,000 PSI)	<b>Material</b>	Body Forged aluminum alloy Trim Steel and Stainless steel O-rings Synthetic rubber
<b>Sizes</b>	NPT 1/4"	<b>Operating Temperature</b>	-40°C to +121°C (-40°F to +250°F)
<b>Orifice Dia.</b>	1/8"		
<b>Ports</b>	NPT Pipe threads		

**Ordering Information**

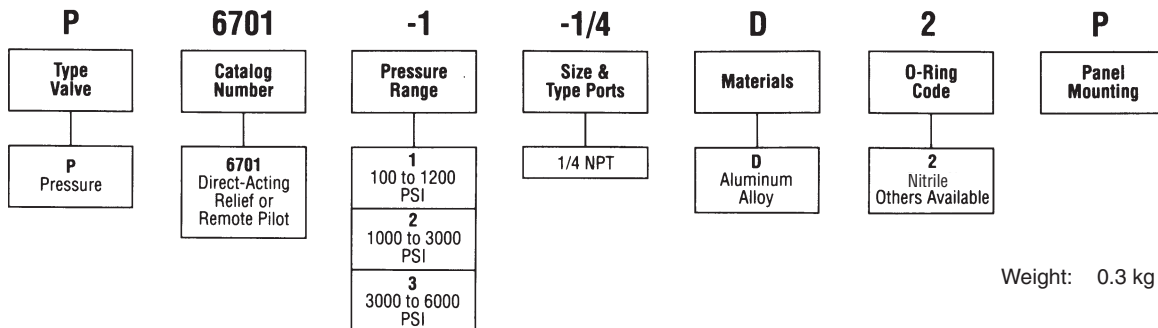

**Performance Curves**

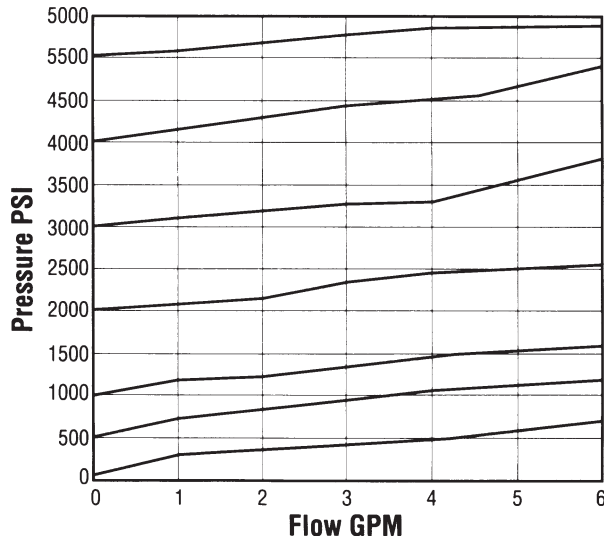

**Dimensions** — Shown in inches

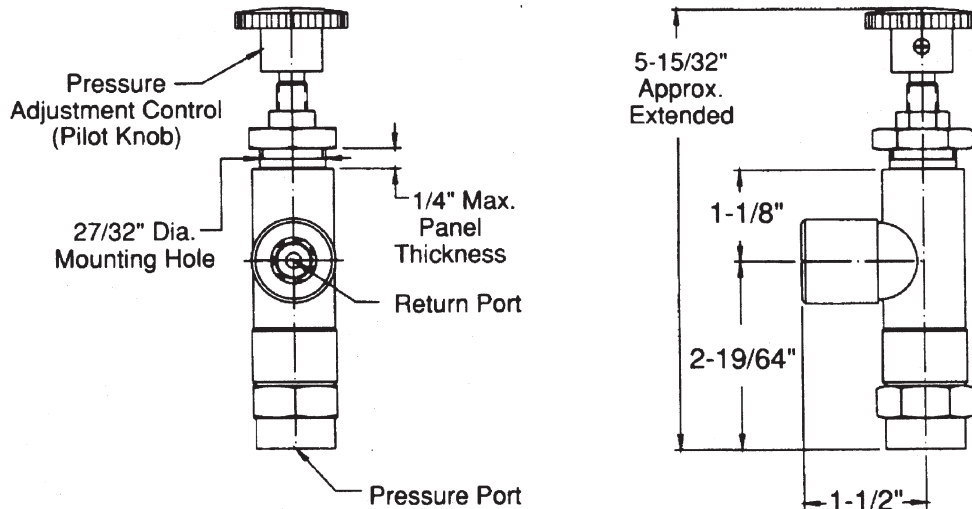

**General Description**

Series PR6701 pressure reducing pressure control valves maintain an independently controlled constant outlet pressure on one leg of the hydraulic system, regardless of pressure at the valve inlet or on the main relief valve. Inlet pressure on the valve must be higher than the pressure setting on the valve.

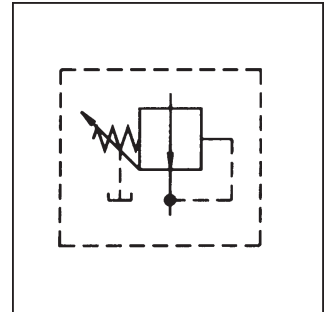
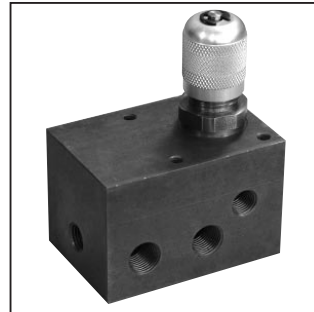

**Features**

- Recommended where limited reduced hydraulic pressure is required without using additional low pressure pump.
- Designed for up to 414 Bar (6000 PSI) primary pressure.
- Maintains regulated pressure within  $\pm 5\%$  under flow conditions.

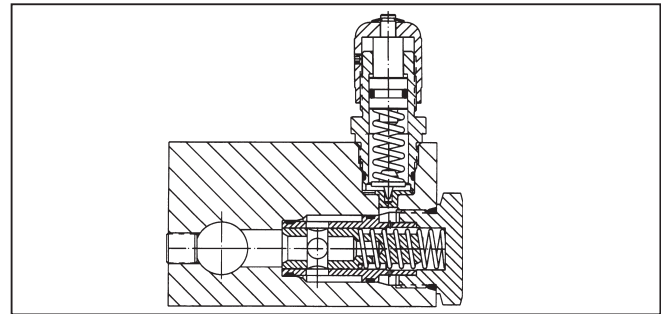

**Specifications**

<b>Service App.</b>	Hydraulic Oil	<b>Sizes</b>	NPT 1/4", 1/2", 3/4"
<b>Pressure Adjustment Range</b>	Range 1: Maximum Primary Pressure 138 Bar (2000 PSI) Regulated Secondary Pressure 13.8 - 82.8 Bar (200 - 1200 PSI)	<b>Ports</b>	NPT Pipe threads
	Range 2: Maximum Primary Pressure 207 Bar (3000 PSI) Regulated Secondary Pressure 69 - 207 Bar (1000 - 3000 PSI)	<b>Mounting</b>	In-line or panel
	Range 3: Maximum Primary Pressure 414 Bar (6000 PSI) Regulated Secondary Pressure 207 - 414 Bar (3000 - 6000 PSI)	<b>Material</b>	Body, Cap, Piston Sleeve, Pilot Cap Steel
<b>Maximum Operating Pressure</b>	Proof: Ranges 1 & 2 310.5 Bar (4500 PSI) Range 3 621 Bar (9000 PSI)		Pilot Knob Aluminum
	Burst: Ranges 1 & 2 517.5 Bar (7500 PSI) Range 3 1035 Bar (15000 PSI)	Piston, Adjustable Stem, Pilot Piston, Pilot Seat 400 Stainless Steel	O-rings Synthetic rubber
		Back-up Rings PTFE	Body Finish Paint
		<b>Operating Temperature</b>	-40°C to +121°C (-40°F to +250°F)

**Flow Data**

Valve Size	CV Factor Inlet to Inlet	Flow, Max LPM (GPM)	Max. Pilot Flow to Tank	Weight kg (lbs.)
1/4	1.1	22.7 (6)	0.7 LPM (.18 GPM)	2.2 (4.75)
1/2	3.5	56.8 (15)	0.8 LPM (.21 GPM)	3.2 (7.0)
3/4	4.5	94.6 (25)	0.8 LPM (.22 GPM)	4.4 (9.6)

**Ordering Information**

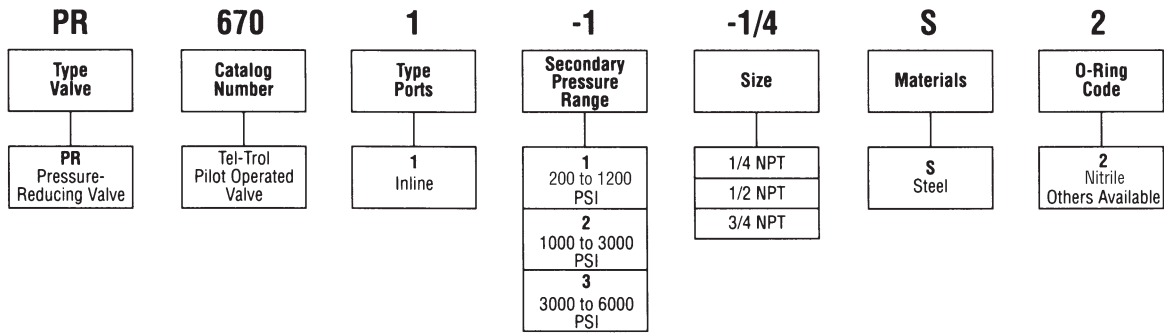

**Dimensions** — Shown in inches

**Panel Mounting Dimensions**

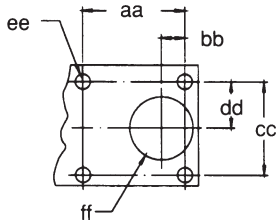

**Panel Machining for Panel Mounted Valves**

Valve Size	aa	bb	cc	dd	ee	ff	Mounting Threads
1/4	1.750	0.531	1.750	0.875	0.281	1.4375	1/4 - 20NC-2
1/2							
3/4	2.312	0.531	2.125	1.062	0.343	1.4375	5/16 - 18NC-2

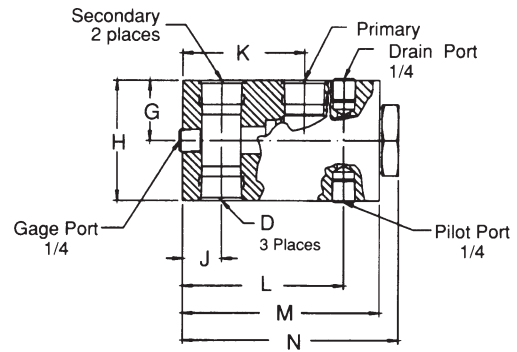
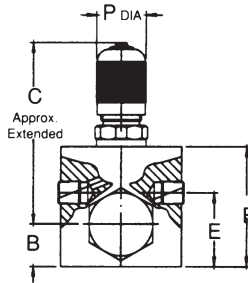
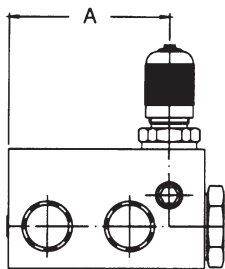

Valve Size	A	B	C	Port Type D	E	F	G	H	J	K	L	M	N	P
1/4	2.313	.750	4.000	1/4 NPT	1.313	2.375	1.187	2.375	.625	1.563	2.313	3.125	3.437	1.125
1/2	3.188	.968	4.156	1/2 NPT	1.688	2.750	1.125	2.250	.750	2.250	3.188	4.000	4.437	1.125
3/4	3.688	.968	4.156	3/4 NPT	1.688	2.750	1.375	2.750	.891	2.781	3.688	4.500	4.937	1.125

### General Description

Series SPC sandwich type pressure compensators are typically used in combination with proportional directional control valves. The compensator keeps the pressure drop over the directional valve constant and thus provides load-independent flow to the actuator.

### Features

- 2-way or 3-way pressure compensators.
- Standard pressure differential 5 Bar (73 PSI).
- Adjustable differential (2 to 5 Bar) (29 to 73 PSI) and 10 Bar (145 PSI) selectable by model code.
- Sizes
 

NG06 / CETOP 3	SPC01
NG10 / CETOP 5	SPC02
NG16 / CETOP 7	upon request
NG25 / CETOP 8	upon request

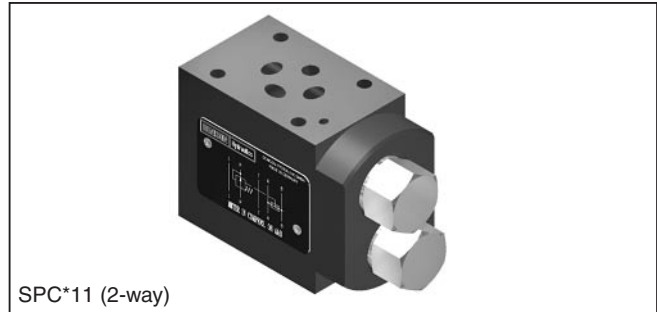

SPC\*11 (2-way)

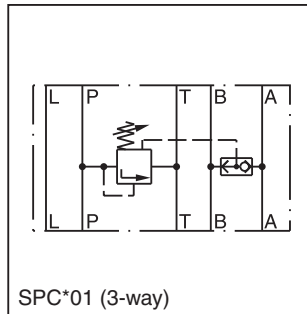

SPC\*01 (3-way)

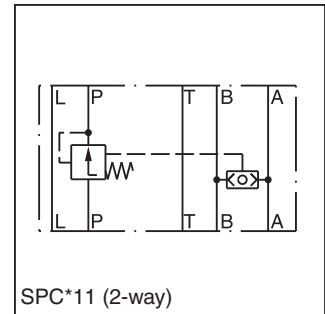

SPC\*11 (2-way)

### Specifications

General		
<b>Size</b>	<b>NG6</b>	<b>NG10</b>
<b>Mounting Interface</b>	DIN 24340 A10 ISO 4401 NFFA D05 CETOP 03	DIN 24340 A16 ISO 4401 NFFA D07 CETOP 05
<b>Mounting Position</b>	Unrestricted	
<b>Ambient Temperature</b>	-20°C to +50°C (-4°F to +122°F)	
Hydraulic		
<b>Maximum Operating Pressure</b>		
<b>Drain Port L Connected:</b>	P, A, B: 350 Bar (5075 PSI),; T: 210 Bar (3045 PSI), L: 10 Bar (145 PSI)	P, A, B: 315 Bar (4568 PSI), T: 210 Bar (3045 PSI), L: 10 Bar (145 PSI)
<b>Without Drain Port:</b>	P, A, B: 350 Bar (5075 PSI), T: 160 Bar (2320 PSI), L: 160 Bar (2320 PSI)	P, A, B: 315 Bar (4568 PSI), T: 210 Bar (3045 PSI), L: 210 Bar (3045 PSI)
<b>Nominal Flow</b>	30 LPM (10.6 GPM)	80 LPM (26.5 GPM)
<b>Fluid</b>	Hydraulic oil as per DIN 51524 ... 51525	
<b>Fluid Temperature</b>	-20°C to +80°C (-4°F to +176°F)	
<b>Viscosity Permitted</b>	10 to 650 cSt (mm <sup>2</sup> /s)	
<b>Viscosity Recommended</b>	30 cSt (mm <sup>2</sup> /s)	
<b>Filtration</b>	ISO 4406 (1999) 18/16/13 (acc. NAS 1638: 7)	



**Ordering Information**

<b>SPC</b> Direct Operated Pressure Compensator	<b>Nominal Size</b>	<b>Function</b>	<b>Pressure Differential</b>	<b>1</b> Circuit Type	<b>C</b> Load Sensing Port	<b>5</b> Steel Body	<b>A</b> Design Series	<b>Seals</b>
--	---------------------	-----------------	------------------------------	--------------------------	-------------------------------	------------------------	---------------------------	--------------

Code	Description*
01	NG6
02	NG10

\* Sizes NG16 and NG25 on request.

Code	Description
04*	2 to 5 Bar (29 to 73 PSI) Adjustable
05	5 Bar (73 PSI)
10*	10 Bar (145 PSI)

\* For 3-way compensator only.

Code	Description
01	3-Way Pressure Compensation
11	2-Way Pressure Compensation

Weight:	2-Way Compensator	3-Way Compensator
SPC01	1.5 kg (3.3 lbs)	1.6 kg (3.5 lbs)
SPC02	3.1 kg (6.8 lbs.)	3.5 kg (7.7 lbs.)

**SPC01**

Type	Model No.	Order No.
3-Way Compensators with Shuttle Valve P-A/B	SPC 01 01 041C5A	026-42583-0
	SPC 01 01 051C5A	026-42584-0
	SPC 01 01 101C5A	026-42585-0
2-Way Compensators with Shuttle Valve P-A/B	SPC 01 11 051C5A	026-42560-0

**SPC02**

Type	Model No.	Order No.
3-Way Compensators with Shuttle Valve P-A/B	SPC 02 01 041C5A	026-42589-0
	SPC 02 01 051C5A	026-42590-0
	SPC 02 01 101C5A	026-42591-0
2-Way Compensators with Shuttle Valve P-A/B	SPC 02 11 051C5A	026-42566-0

**Performance Curves**

**SPC01**

**Flow Regulation Example:  
 2-Way Pressure Compensator**

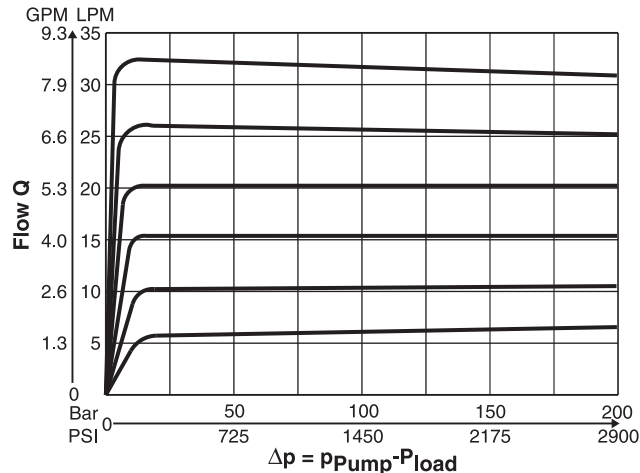
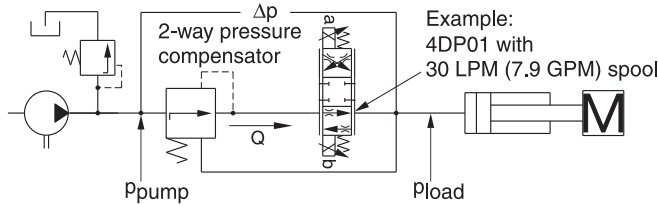

**SPC02**

**Flow regulation Example:  
 2-Way Pressure Compensator**

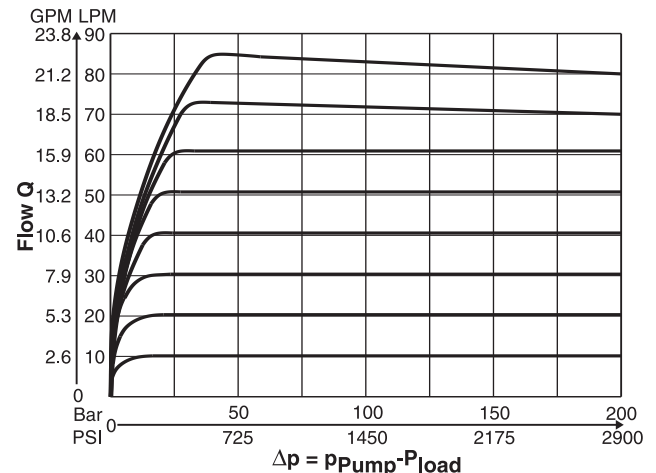
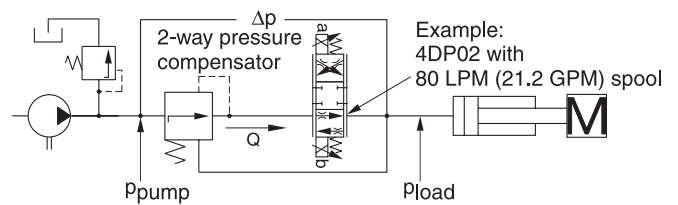

**2-Way Pressure Compensator**

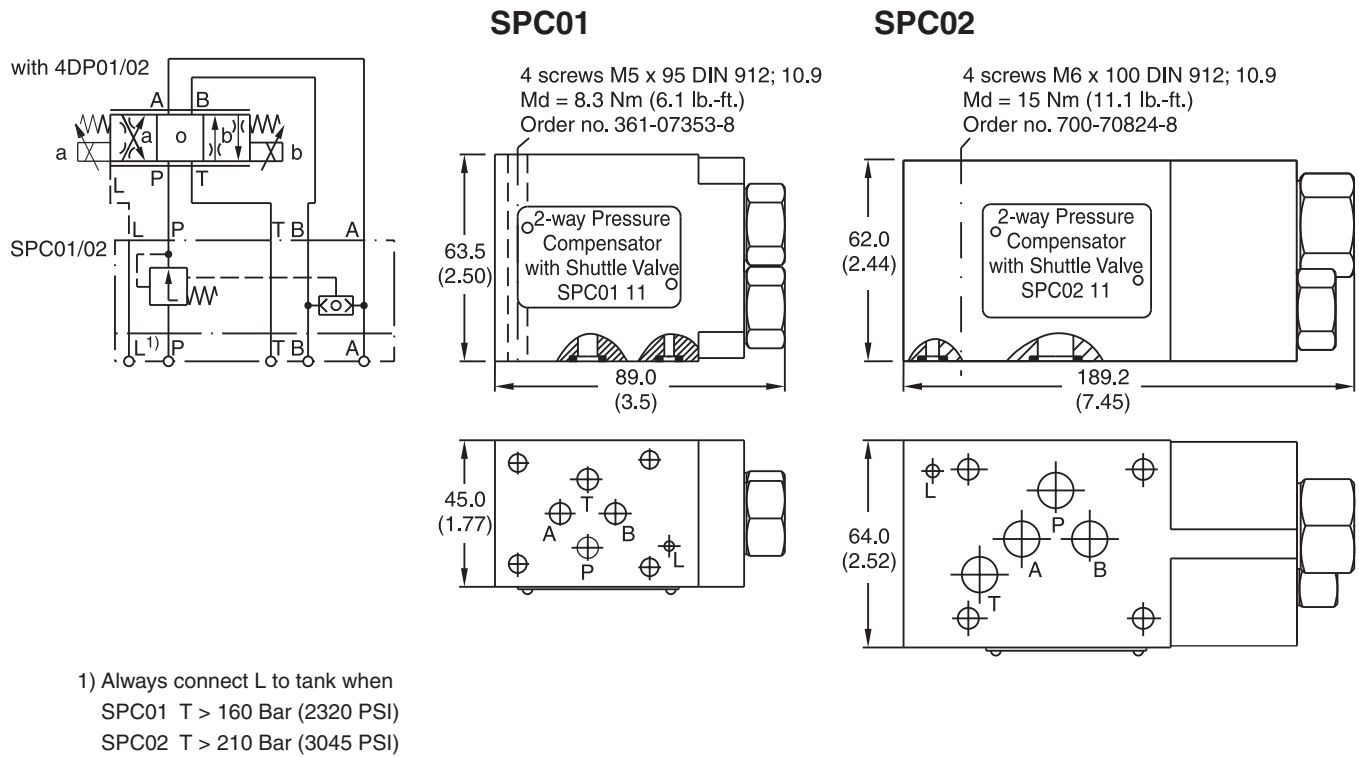

**3-Way Pressure Compensator**

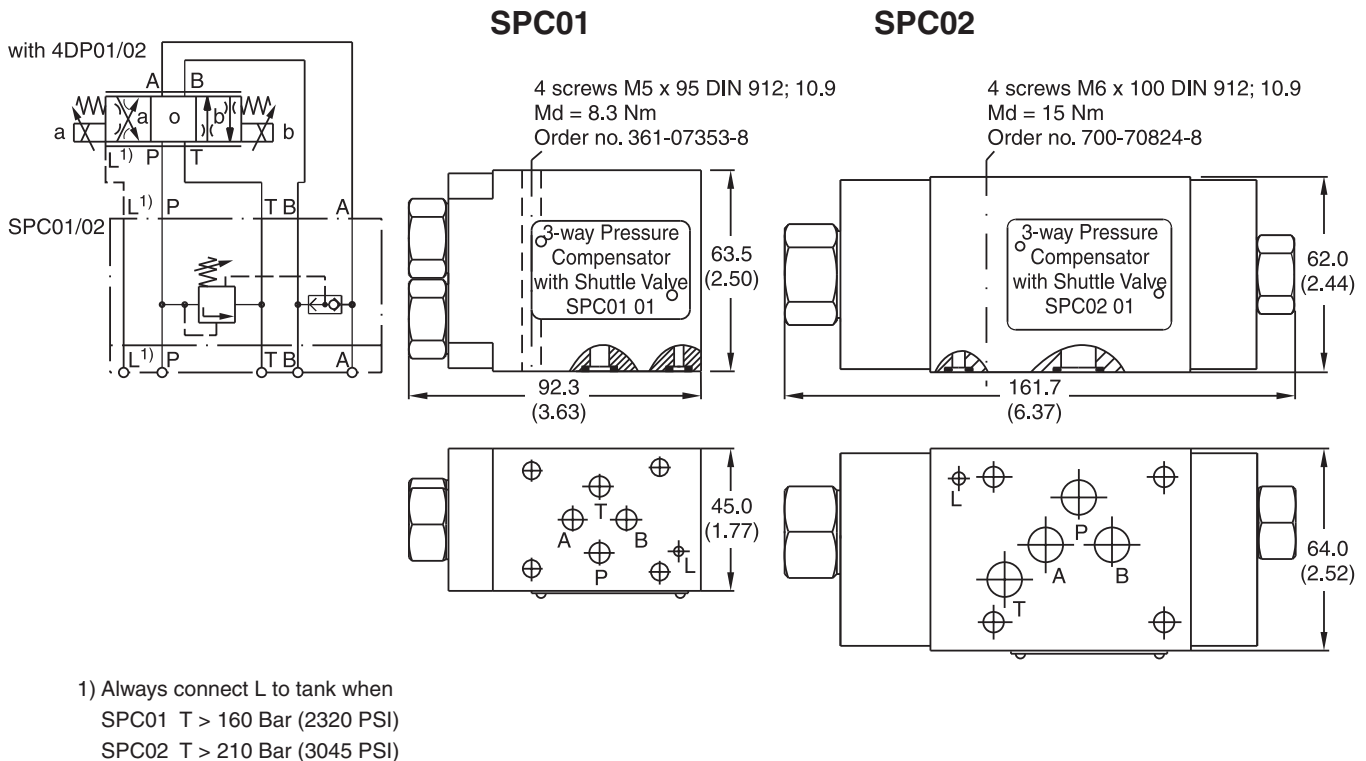

## General Description

Series ZDR pilot operated pressure reducing valves are designed for maximum flow rates.

The reducing function can be located in the ports P, A or B. The sizes NG06 and NG10 are equipped with an integral return flow check valve (reducing function in A or B).

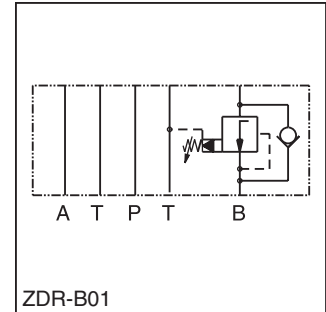

## Features

- High flow capacity.
- Sizes
  - ZDR01 – NG06 / CETOP3
  - ZDR02 – NG10 / CETOP5
  - ZDR03 – NG16 / CETOP7
- With integral return flow check valve.

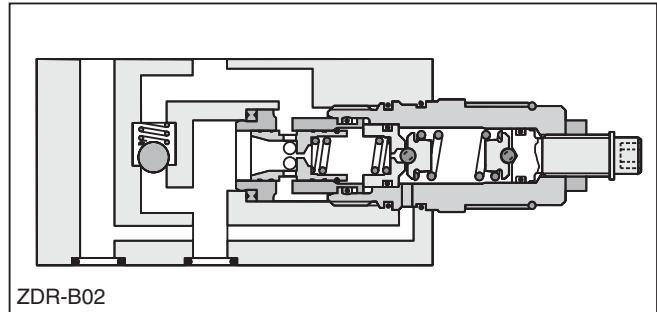

## Specifications

General			
<b>Size</b>	<b>NG6</b>	<b>NG10</b>	<b>NG16</b>
<b>Mounting Interface</b>	DIN 24340 A6 ISO 4401 NFFA D03 CETOP RP 121	DIN 24340 A10 ISO 4401 NFFA D05 CETOP RP 121	DIN 24340 A16 ISO 4401 NFFA D08 CETOP RP 121
<b>Mounting Position</b>	Unrestricted		
<b>Ambient Temperature Range</b>	-20°C to +50°C (-4°F to +122°F)		
Hydraulic			
<b>Maximum Operating Pressure</b>	up to 350 Bar (5075 PSI); ZDR-AR / BR up to 315 Bar (4568 PSI)		
<b>Nominal Flow</b>	80 LPM (21.2 GPM)	120 LPM (31.7 GPM)	250 LPM (66.1 GPM)
<b>Pilot Oil</b>	0.2 LPM (0.1 GPM)	0.3 LPM (0.1 GPM)	0.7 LPM (0.2 GPM)
<b>Fluid</b>	Hydraulic oil as per DIN 51524 ... 51525		
<b>Fluid Temperature</b>	-20°C to +80°C (-4°F to +176°F)		
<b>Viscosity Permitted</b>	10 to 650 cSt (mm <sup>2</sup> /s)		
<b>Viscosity Recommended</b>	30 cSt (mm <sup>2</sup> /s)		
<b>Filtration</b>	ISO Class 4406 (1999) 18/16/13 (acc. NAS 1638: 7)		

<b>ZDR</b> Pressure Reducing Valve	—	<input type="checkbox"/>	—	<input type="checkbox"/>	—	<input type="checkbox"/>	<b>S0</b> Hexagon Screw with Lock Nut	—	<input type="checkbox"/>	—	<input type="checkbox"/>	Seals																					
		<b>Pressure Control</b>		<b>Nominal Size</b>		<b>Pressure Stages</b>			<b>Design Series</b>																								
				<table border="1"> <thead> <tr><th>Code</th><th>Description</th></tr> </thead> <tbody> <tr><td>01</td><td>NG6</td></tr> <tr><td>02</td><td>NG10</td></tr> <tr><td>03</td><td>NG16</td></tr> </tbody> </table>	Code	Description	01	NG6	02	NG10	03	NG16		<table border="1"> <thead> <tr><th>Code</th><th>Description</th></tr> </thead> <tbody> <tr><td>1</td><td>up to 100 Bar (1450 PSI)</td></tr> <tr><td>5</td><td>up to 350 Bar (5075 Bar)</td></tr> </tbody> </table>	Code	Description	1	up to 100 Bar (1450 PSI)	5	up to 350 Bar (5075 Bar)			<table border="1"> <thead> <tr><th>Code</th><th>Description</th></tr> </thead> <tbody> <tr><td>1</td><td>Nitrile</td></tr> <tr><td>5</td><td>Fluorocarbon</td></tr> </tbody> </table>	Code	Description	1	Nitrile	5	Fluorocarbon				
Code	Description																																
01	NG6																																
02	NG10																																
03	NG16																																
Code	Description																																
1	up to 100 Bar (1450 PSI)																																
5	up to 350 Bar (5075 Bar)																																
Code	Description																																
1	Nitrile																																
5	Fluorocarbon																																
		<table border="1"> <thead> <tr><th>Code</th><th>Size</th><th>Description</th></tr> </thead> <tbody> <tr><td>P</td><td>06/10/16</td><td>Pressure reducing in P with pressure gauge port M</td></tr> <tr><td>AR</td><td>06/10</td><td>Pressure reducing in A with check valve</td></tr> <tr><td>BR</td><td>06/10</td><td>Pressure reducing in B with check valve</td></tr> <tr><td>A</td><td>16</td><td>Pressure reducing in A</td></tr> <tr><td>B</td><td>16</td><td>Pressure reducing in B</td></tr> </tbody> </table>	Code	Size	Description	P	06/10/16	Pressure reducing in P with pressure gauge port M	AR	06/10	Pressure reducing in A with check valve	BR	06/10	Pressure reducing in B with check valve	A	16	Pressure reducing in A	B	16	Pressure reducing in B			<table border="1"> <thead> <tr><th>Code</th><th>Description</th></tr> </thead> <tbody> <tr><td>C</td><td>16</td></tr> <tr><td>D</td><td>06/10</td></tr> </tbody> </table>	Code	Description	C	16	D	06/10				
Code	Size	Description																															
P	06/10/16	Pressure reducing in P with pressure gauge port M																															
AR	06/10	Pressure reducing in A with check valve																															
BR	06/10	Pressure reducing in B with check valve																															
A	16	Pressure reducing in A																															
B	16	Pressure reducing in B																															
Code	Description																																
C	16																																
D	06/10																																
													<table border="1"> <thead> <tr><th>Weight:</th><th>ZDR-P</th><th>ZDR-AR/BR</th></tr> </thead> <tbody> <tr><td>NG6</td><td>1.6 kg (3.5 lbs.)</td><td>1.8 kg (4.0 lbs.)</td></tr> <tr><td>NG10</td><td>2.9 kg (6.4 lbs.)</td><td>3.0 kg (6.6 lbs.)</td></tr> <tr><td>NG16</td><td>8.65 kg (19.1 lbs.)</td><td>8.65 kg (19.1 lbs.)</td></tr> </tbody> </table>	Weight:	ZDR-P	ZDR-AR/BR	NG6	1.6 kg (3.5 lbs.)	1.8 kg (4.0 lbs.)	NG10	2.9 kg (6.4 lbs.)	3.0 kg (6.6 lbs.)	NG16	8.65 kg (19.1 lbs.)	8.65 kg (19.1 lbs.)								
Weight:	ZDR-P	ZDR-AR/BR																															
NG6	1.6 kg (3.5 lbs.)	1.8 kg (4.0 lbs.)																															
NG10	2.9 kg (6.4 lbs.)	3.0 kg (6.6 lbs.)																															
NG16	8.65 kg (19.1 lbs.)	8.65 kg (19.1 lbs.)																															

**ZDR01**

Pressure reducing in P with pressure gauge port M

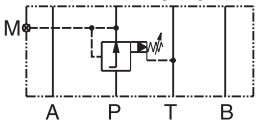

Series  
 ZDR-P01-1-S0-D1  
 ZDR-P01-5-S0-D1

Order No.  
 098-91179-0  
 098-91211-0

Pressure reducing in A with check valve

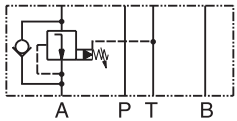

Series  
 ZDR-AR01-1-S0-D1  
 ZDR-AR01-5-S0-D1

Order No.  
 098-91212-0  
 098-91213-0

Pressure reducing in B with check valve

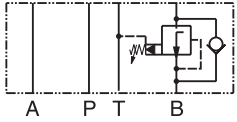

Series  
 ZDR-BR01-1-S0-D1  
 ZDR-BR01-5-S0-D1

Order No.  
 098-91214-0  
 098-91215-0

1 = 7 ... 70 bar  
 5 = 7 ... 350 bar

**ZDR02**

Pressure reducing at P (with pressure gauge port M)

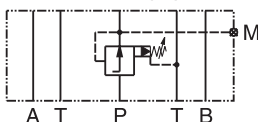

Series  
 ZDR-P02-1-S0-D1  
 ZDR-P02-5-S0-D1

Order No.  
 098-91050-0  
 098-91051-0

Pressure reducing at A (with check valve)

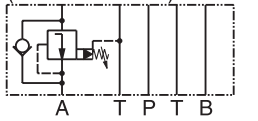

Series  
 ZDR-AR02-1-S0-D1  
 ZDR-AR02-5-S0-D1

Order No.  
 098-91052-0  
 098-91053-0

Pressure reducing at B (with check valve)

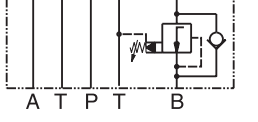

Series  
 ZDR-BR02-1-S0-D1  
 ZDR-BR02-5-S0-D1

Order No.  
 098-91054-0  
 098-91055-0

**ZDR03**

Pressure reducing in P

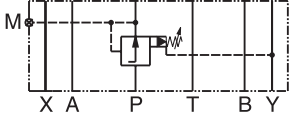

Series  
 ZDR-P03-1-S0-C1  
 ZDR-P03-5-S0-C1

Order No.  
 098-91409-0  
 098-91410-0

Pressure reducing in A

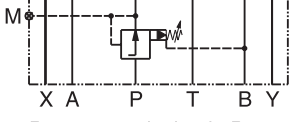

Series  
 ZDR-A03-1-S0-C1  
 ZDR-A03-5-S0-C1

Order No.  
 098-91412-0  
 098-91429-0

Pressure reducing in B

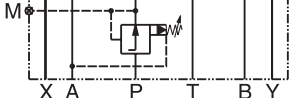

Series  
 ZDR-B03-1-S0-C1  
 ZDR-B03-5-S0-C1

Order No.  
 098-91430-0  
 098-91414-0

ZDR.indd, dd

**ZDR-P/AR/BR01**

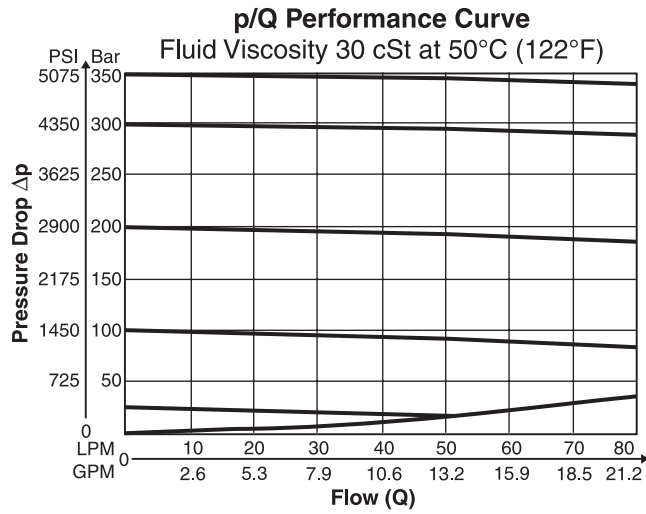

**ZDR-P/AR/BR02**

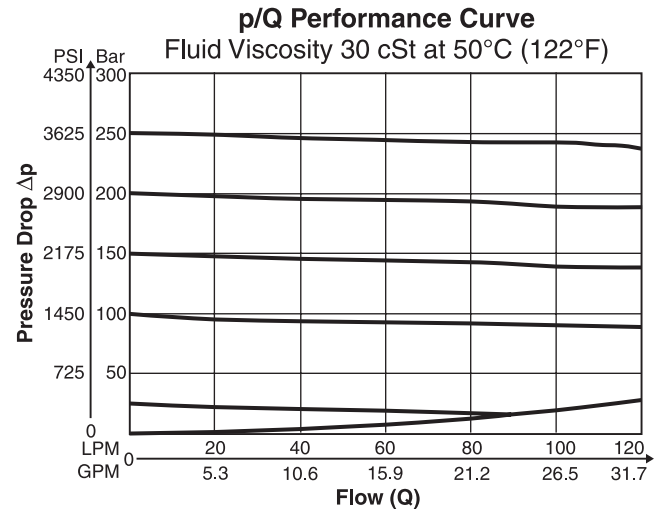

**ZDR-P03-5 (at p = 0 Bar (0 PSI) in Y)**

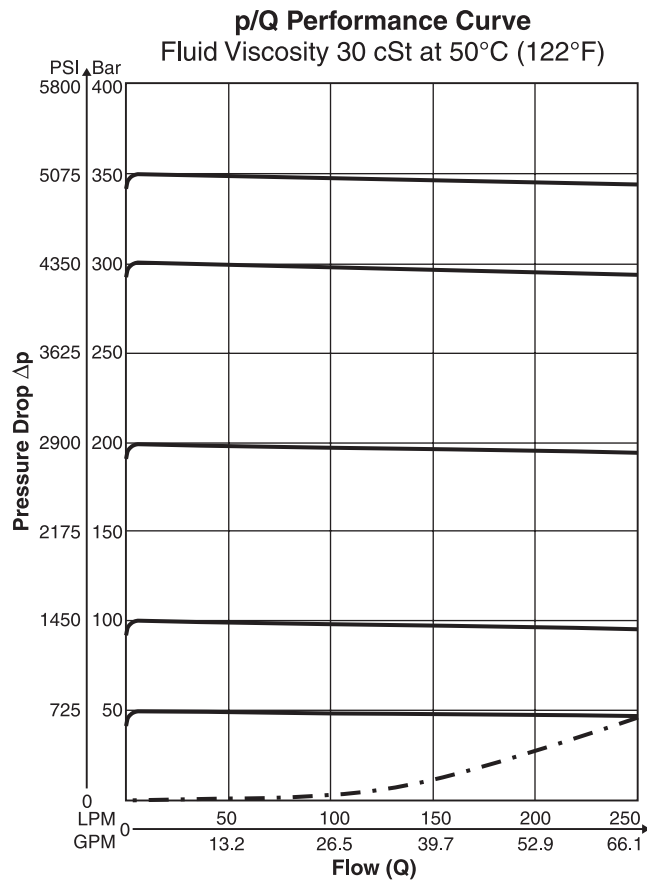

Inch equivalents for millimeter dimensions are shown in (\*\*)

**ZDR01**

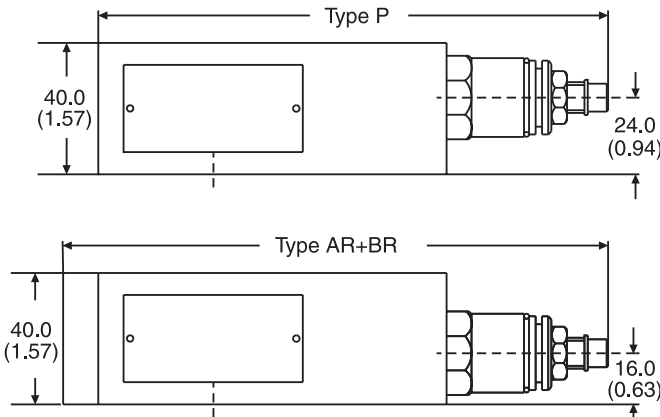
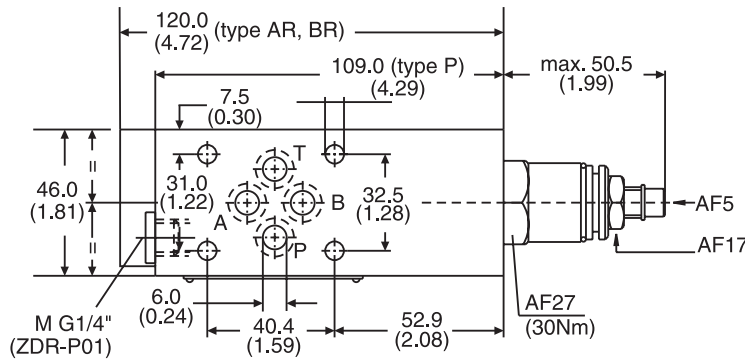

Seal Kit	
Seal	Order Code
1	098-91184-0
5	098-91185-0
Complete Cartridge	
Seal	Order Code
1	098-91102-0
5	098-91103-0

**ZDR02**

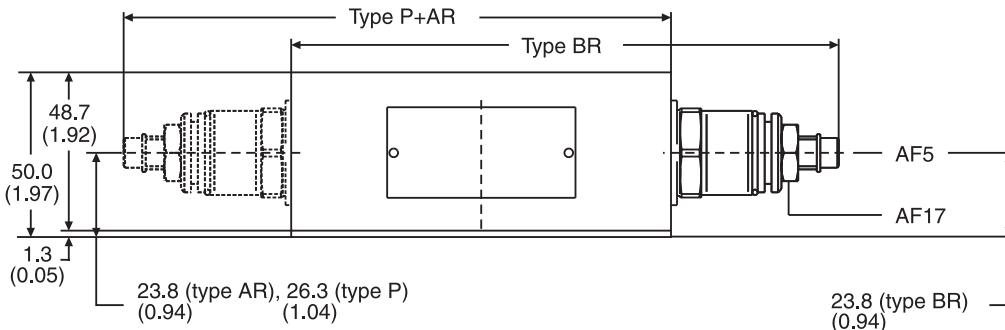
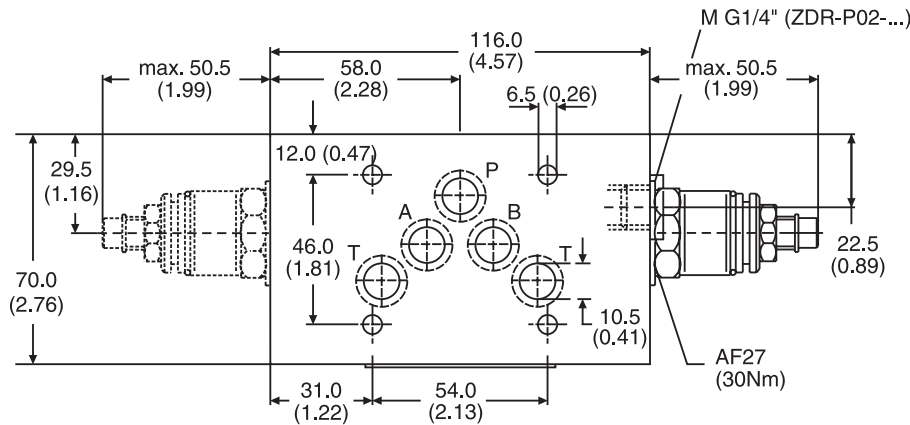

Seal Kit	
Seal	Order Code
1	098-91182-0
5	098-91183-0
Complete Cartridge	
Seal	Order Code
1	098-91102-0
5	098-91103-0

Inch equivalents for millimeter dimensions are shown in (\*\*)

**ZDR03**

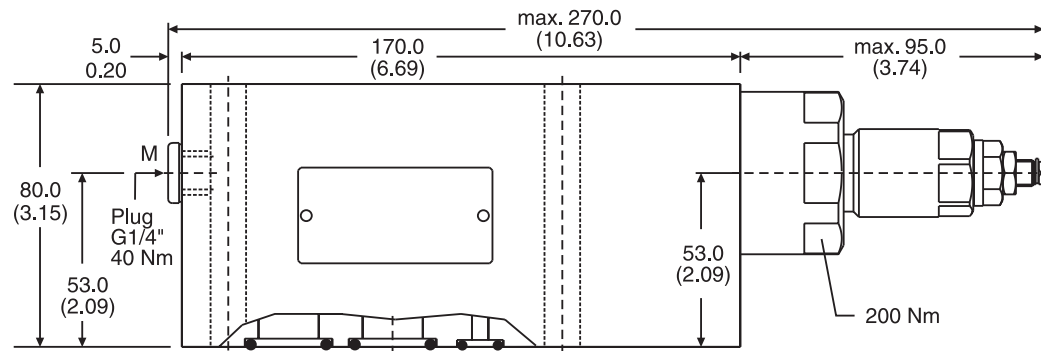
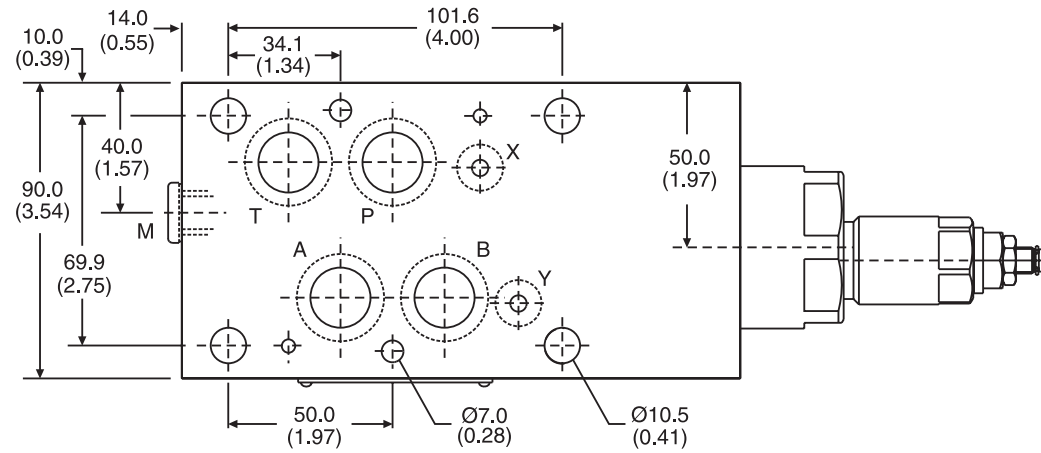

Seal Kit	
Seal	Order Code
1	098-91439-0
5	098-91440-0
Complete Cartridge	
Seal	Order Code
1	098-91437-0
5	098-91438-0

### General Description

Series ZDV pilot operated pressure relief valves are designed for maximum flow rates.

The relief function can be located between P and T, A and T, B and T or A and T + B and T for typical pressure relief functions.

For a pre-charge function the ZDV can be ordered with pressure function between A and B + B and A.

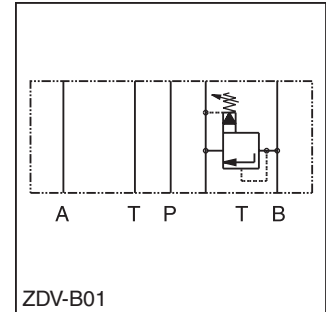

### Features

- High flow capacity.
- Pressure function in P, A, B or A + B.
- Sizes
  - ZDV01 – NG06 / CETOP3
  - ZDV02 – NG10 / CETOP5
  - ZDV03 – NG16 / CETOP7

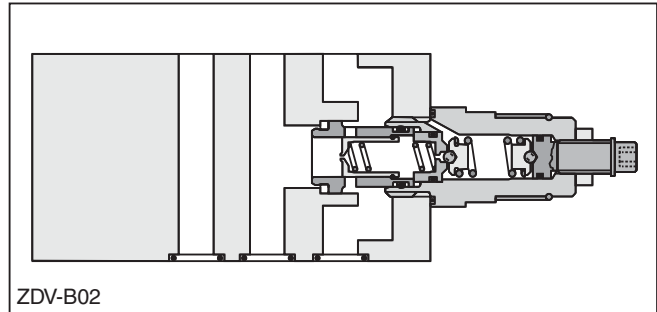

### Specifications

General			
Size	NG6	NG10	NG16
<b>Mounting</b>	DIN 24340 A6 ISO 4401 NFPA D03 CETOP RP 121	DIN 24340 A10 ISO 4401 NFPA D05 CETOP RP 121	DIN 24340 A16 ISO 4401 NFPA D08 CETOP RP 121
<b>Mounting Position</b>	Unrestricted		
<b>Ambient Temperature Range</b>	-20° to +50°C (-4°F to +122°F)		
Hydraulic			
<b>Maximum Operating Pressure</b>	up to 350 Bar (5075 PSI); ZDV*ABS up to 315 Bar (4568 PSI)		
<b>Nominal Flow</b>	80 LPM (21.2 GPM)	140 LPM (37.0 GPM)	300 LPM (79.4 GPM)
<b>Fluid</b>	Hydraulic oil as per DIN 51524 ... 51525		
<b>Fluid Temperature</b>	-20° to +80°C (-4°F to +176°F)		
<b>Viscosity Permitted</b>	10 to 650 cSt (mm <sup>2</sup> /s)		
<b>Viscosity Recommended</b>	30 cSt (mm <sup>2</sup> /s)		
<b>Filtration</b>	ISO Class 4406 (1999) 18/16/13 (acc. NAS 1638: 7)		



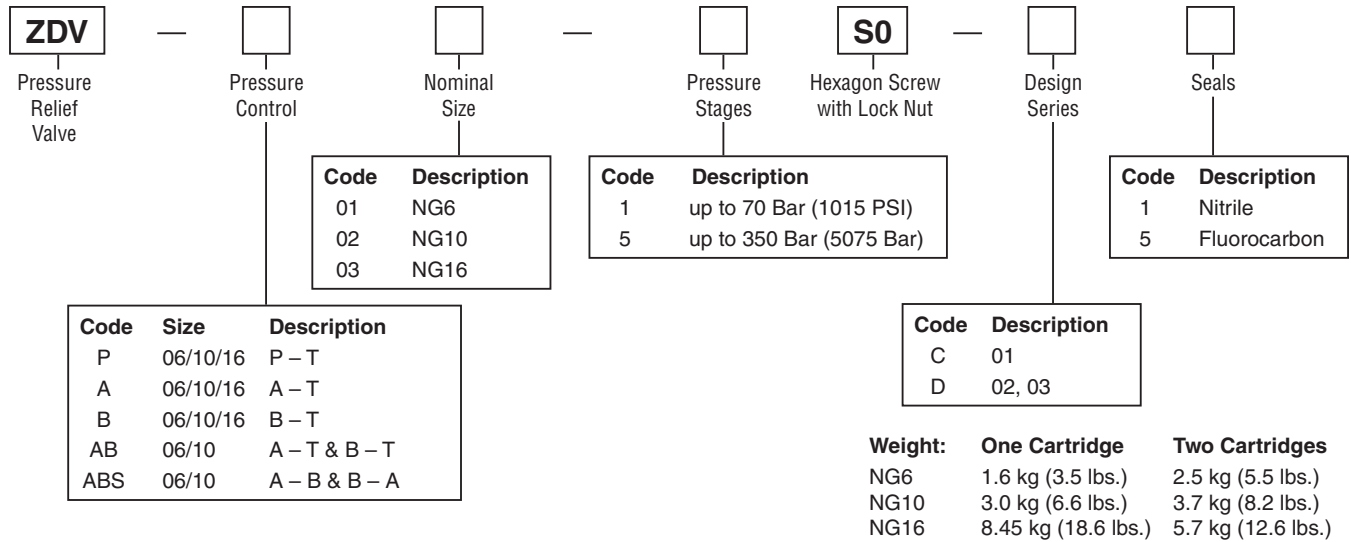

**ZDV01**

Pressure control P-T

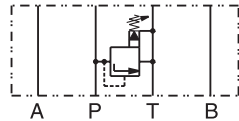

Series  
 ZDV-P01-1-S0-D1  
 ZDV-P01-5-S0-D1

Order No.  
 098-91201-0  
 098-91202-0

Pressure control A-T & B-T

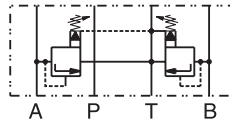

Series  
 ZDV-AB01-1-S0-D1  
 ZDV-AB01-5-S0-D1

Order No.  
 098-91207-0  
 098-91208-0

Pressure control A-T

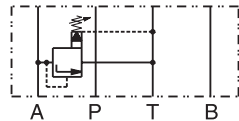

Series  
 ZDV-A01-1-S0-D1  
 ZDV-A01-5-S0-D1

Order No.  
 098-91203-0  
 098-91204-0

Pressure control A-B & B-A

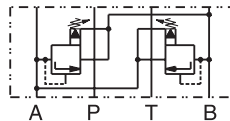

Series  
 ZDV-ABS01-1-S0-D1  
 ZDV-ABS01-5-S0-D1

Order No.  
 098-91209-0  
 098-91210-0

1 = 7 ... 70 bar  
 5 = 7 ... 350 bar

Pressure control B-T

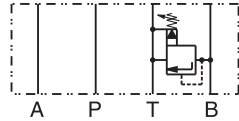

Series  
 ZDV-B01-1-S0-D1  
 ZDV-B01-5-S0-D1

Order No.  
 098-91205-0  
 098-91206-0

1 = 7 ... 70 bar  
 5 = 7 ... 350 bar

**ZDV02**

Pressure control P-T

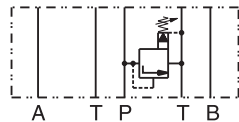

Series  
 ZDV-P02-1-S0-D1  
 ZDV-P02-5-S0-D1

Order No.  
 098-91034-0  
 098-91035-0

Pressure control A-T & B-T

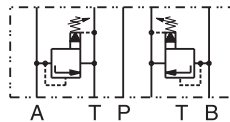

Series  
 ZDV-AB02-1-S0-D1  
 ZDV-AB02-5-S0-D1

Order No.  
 098-91040-0  
 098-91041-0

Pressure control A-T

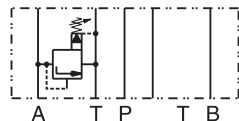

Series  
 ZDV-A02-1-S0-D1  
 ZDV-A02-5-S0-D1

Order No.  
 098-91036-0  
 098-91037-0

Pressure control A-B & B-A

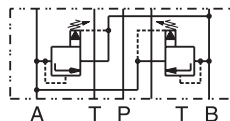

Series  
 ZDV-ABS02-1-S0-D1  
 ZDV-ABS02-5-S0-D1

Order No.  
 098-91042-0  
 098-91043-0

Pressure control B-T

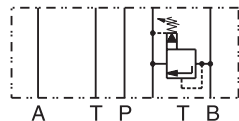

Series  
 ZDV-B02-1-S0-D1  
 ZDV-B02-5-S0-D1

Order No.  
 098-91038-0  
 098-91039-0

**ZDV03 (Continued on Next Page)**

**ZDV03**

Pressure control P-T

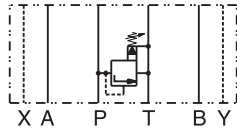

Series  
 ZDV-P03-1-S0-C1      Order No. 098-91432-0  
 ZDV-P03-5-S0-C1      Order No. 098-91418-0

Pressure control B-T

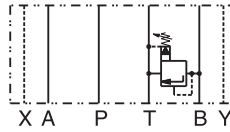

Series  
 ZDV-B03-1-S0-C1      Order No. 098-91431-0  
 ZDV-B03-5-S0-C1      Order No. 098-91417-0

Pressure control A-T

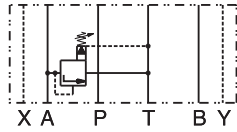

Series  
 ZDV-A03-1-S0-C1      Order No. 098-91415-0  
 ZDV-A03-5-S0-C1      Order No. 098-91416-0

**Performance Curves  
 ZDV-P03-5**

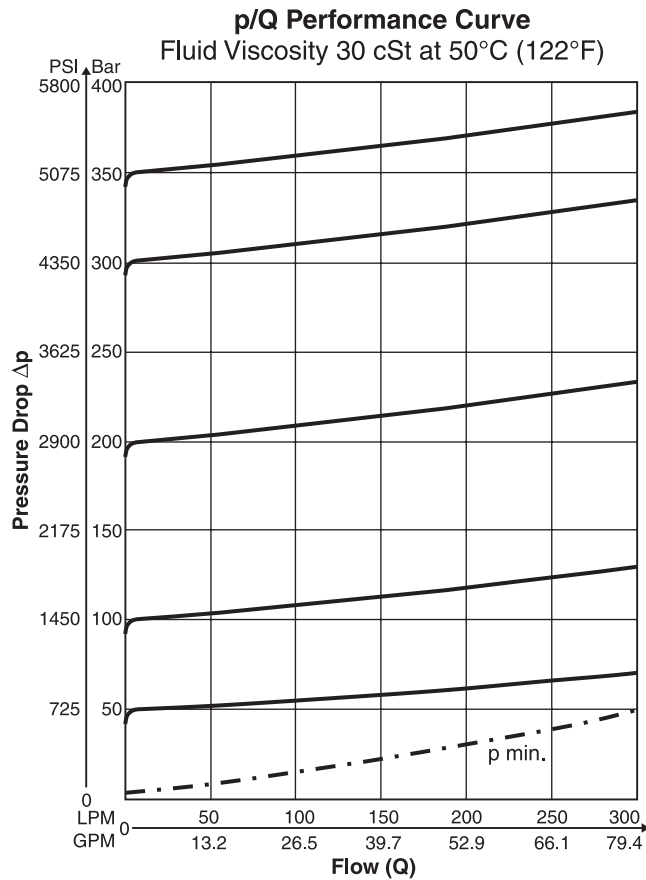

**ZDV-P/A/B/ABS01**

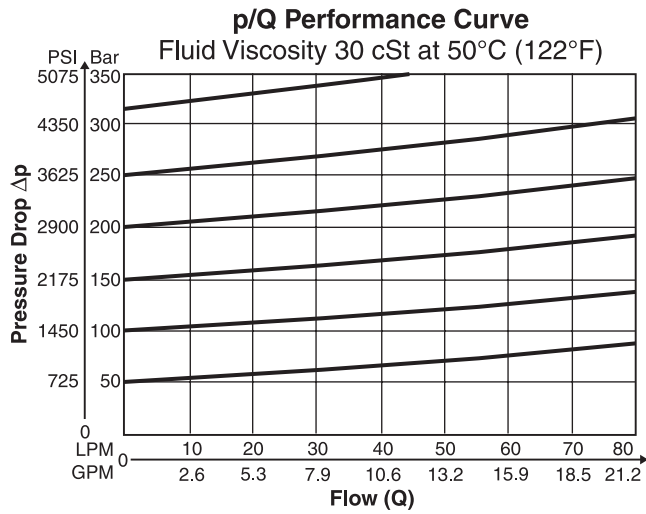

**ZDV-AB01**

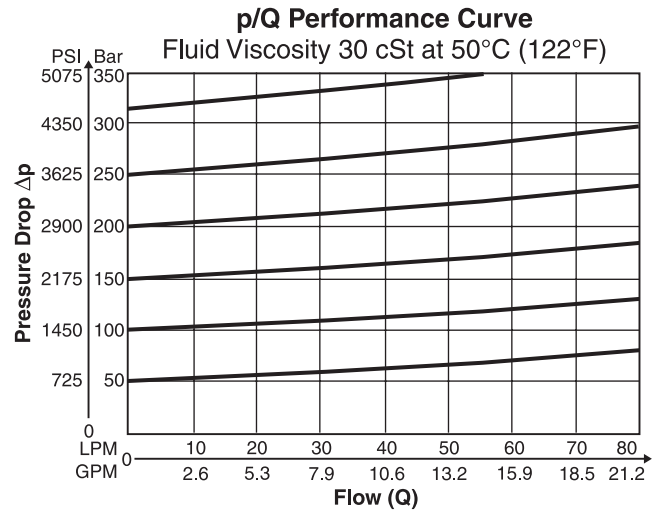

**ZDV-P/A/B/AB02**

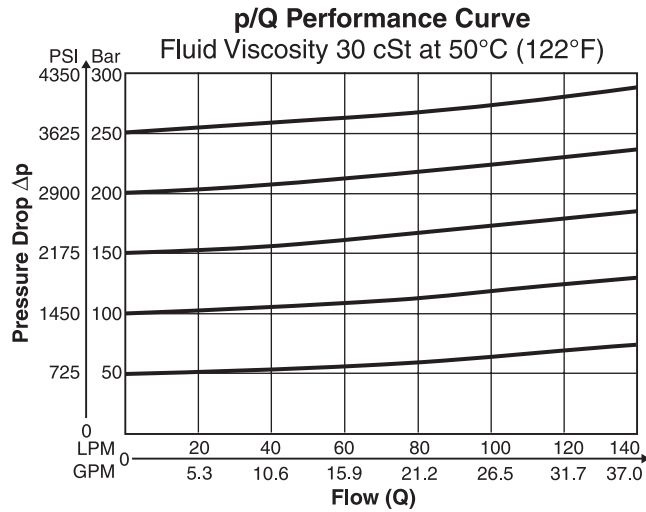

**ZDV-ASB02**

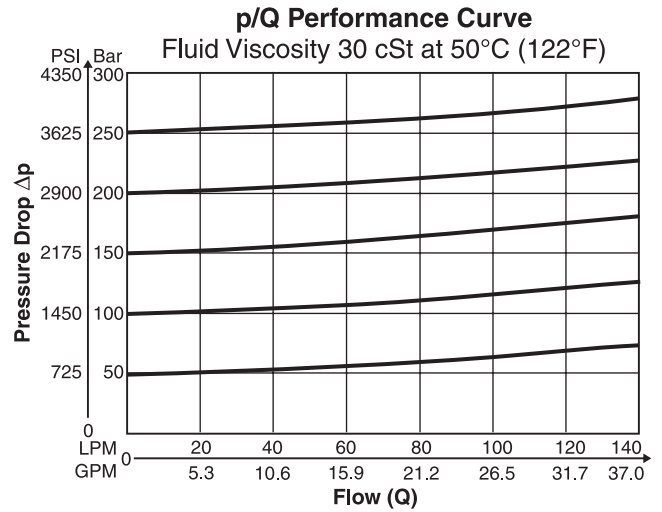

Dimensions

Inch equivalents for millimeter dimensions are shown in (\*\*)

ZDV01

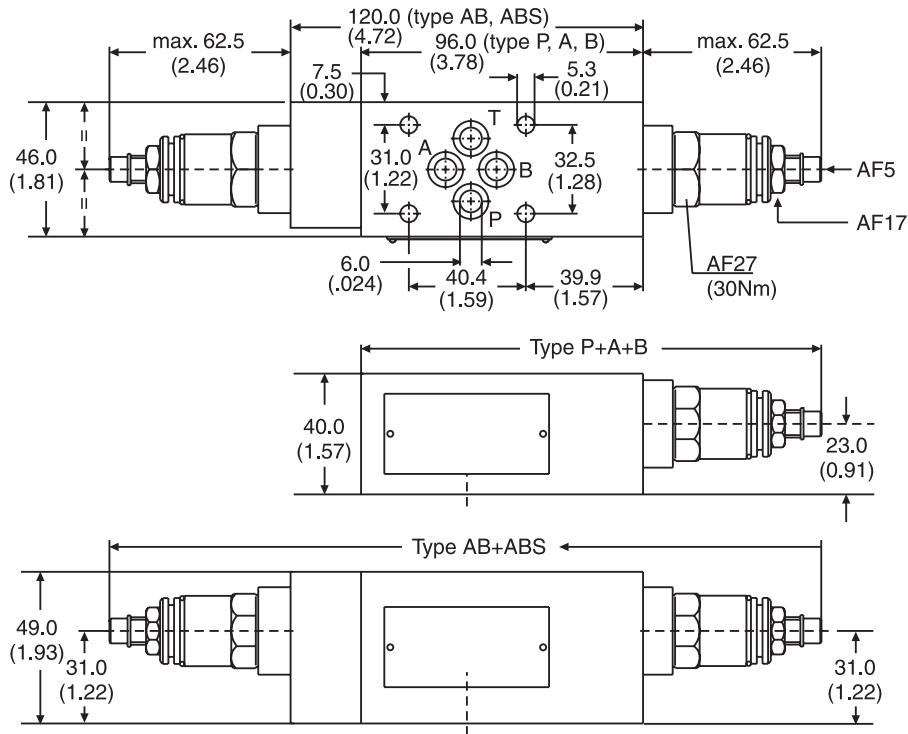

Seal Kit	
Seal	Order Code
1	098-91182-0
5	098-91183-0
Complete Cartridge	
Seal	Order Code
1	098-91116-0
5	098-91117-0

ZDV02

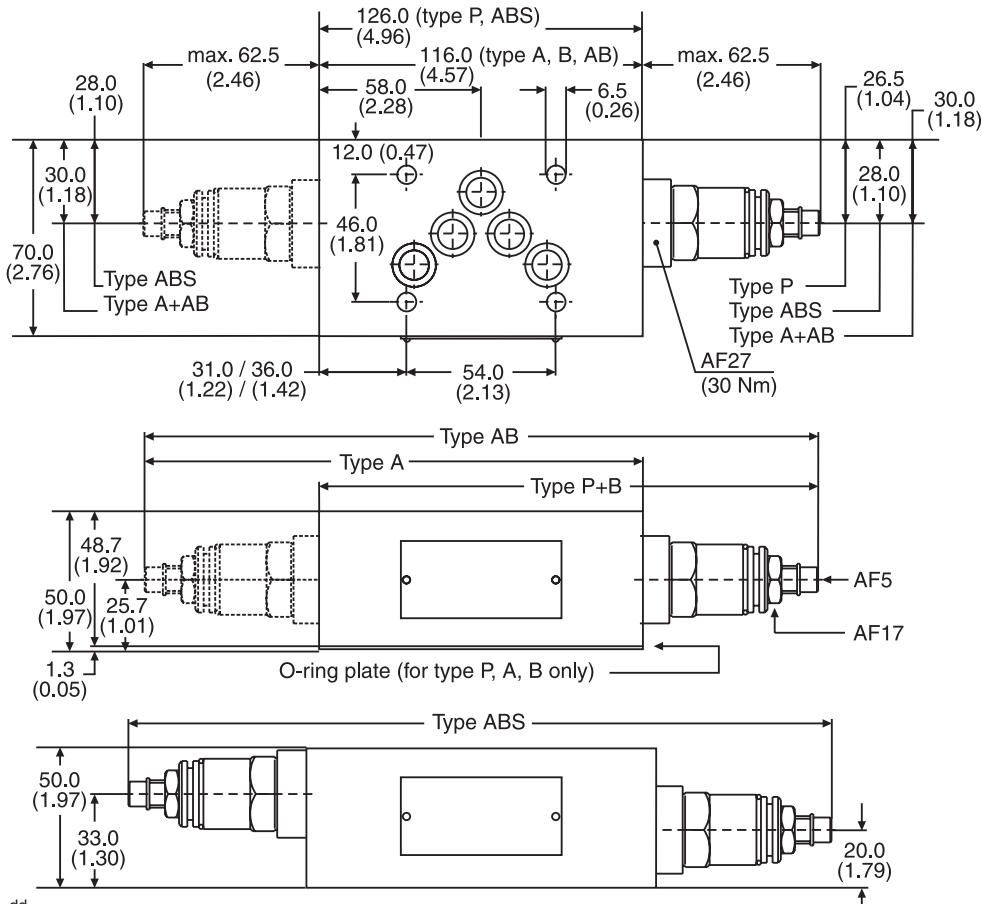

Seal Kit	
Seal	Order Code
1	098-91076-0
5	098-91077-0
Complete Cartridge	
Seal	Order Code
1	098-91116-0
5	098-91117-0

ZDV.indd, dd

### General Description

Series ZRD throttle check valves are designed for maximum flow rates.

The throttle check function can be located in port A or B as well as in A + B. Meter-in or meter-out functionality can be selected by model code.

A low flow / high resolution version in NG06 for sensitive shifting time adjustment of pilot operated directional control valves is available on request.

### Features

- High flow capacity.
- Various functional arrangements.
- Sizes
  - ZRD01 – NG06 / CETOP3
  - ZRD02 – NG10 / CETOP5
  - ZRD03 – NG16 / CETOP7

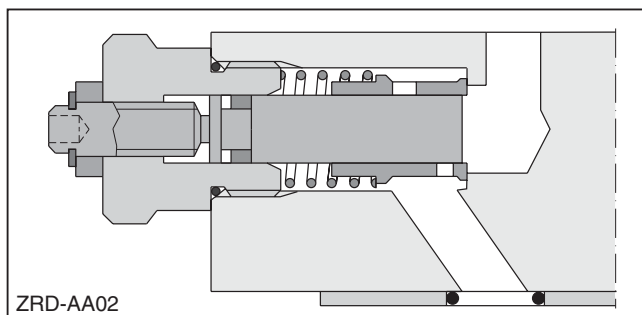
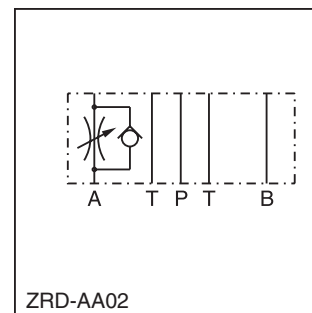

### Specifications

General			
Size	NG6	NG10	NG16
<b>Mounting</b>	DIN 24340 A6 ISO 4401 NFPA D03 CETOP RP 121	DIN 24340 A10 ISO 4401 NFPA D05 CETOP RP 121 5	DIN 24340 A16 ISO 4401 NFPA D08 CETOP RP 121
<b>Mounting Position</b>	Unrestricted		
<b>Ambient Temperature</b>	-20°C to +50°C (-4°F to +122°F)		
Hydraulic			
<b>Max. Operating Pressure</b>	350 Bar (5075 PSI)		
<b>Nominal Flow</b>	80 LPM (21.2 GPM)	160 LPM (42.3 GPM)	260 LPM (68.8 GPM)
<b>Leakage</b>	—	—	0.3 ... 0.5 cSt (at closed throttle)
<b>Cracking Pressure</b>	—	—	0.8 Bar (11.6 PSI)
<b>Fluid</b>	Hydraulic oil as per DIN 51524 ... 51525		
<b>Fluid Temperature</b>	-20°C to +80°C (-4°F to +176°F)		
<b>Viscosity Permitted</b>	10 to 650 cSt (mm <sup>2</sup> /s)		
<b>Viscosity Recommended</b>	30 cSt (mm <sup>2</sup> /s)		
<b>Filtration</b>	ISO 4406 (1999) 18/16/13 (acc. NAS 1638: 7)		

<div style="border: 1px solid black; padding: 2px; display: inline-block;"><b>ZRD</b></div> Throttle Valve with Check	<div style="border: 1px solid black; width: 20px; height: 20px; margin: 0 auto;"></div> Pressure Control	<div style="border: 1px solid black; width: 20px; height: 20px; margin: 0 auto;"></div> Nominal Size	<div style="border: 1px solid black; padding: 2px; display: inline-block;"><b>S0</b></div> Hexagon Screw with Lock Nut	<div style="border: 1px solid black; width: 20px; height: 20px; margin: 0 auto;"></div> Design Series	<div style="border: 1px solid black; width: 20px; height: 20px; margin: 0 auto;"></div> Seals
---	--	--	---	---	--

  

<table border="0" style="width: 100%;"> <thead> <tr> <th style="text-align: left;">Code</th> <th style="text-align: left;">Description</th> </tr> </thead> <tbody> <tr><td>AA</td><td>Meter-out Control in A</td></tr> <tr><td>AZ</td><td>Meter-in Control in A</td></tr> <tr><td>BA</td><td>Meter-out Control in B</td></tr> <tr><td>BB</td><td>Meter-in Control in B</td></tr> <tr><td>ABA</td><td>Meter-out Control in A and B</td></tr> <tr><td>ABZ</td><td>Meter-in Control in A and B</td></tr> </tbody> </table>	Code	Description	AA	Meter-out Control in A	AZ	Meter-in Control in A	BA	Meter-out Control in B	BB	Meter-in Control in B	ABA	Meter-out Control in A and B	ABZ	Meter-in Control in A and B	<table border="0" style="width: 100%;"> <thead> <tr> <th style="text-align: left;">Code</th> <th style="text-align: left;">Description</th> </tr> </thead> <tbody> <tr><td>01</td><td>NG6</td></tr> <tr><td>02</td><td>NG10</td></tr> <tr><td>03</td><td>NG16</td></tr> </tbody> </table>	Code	Description	01	NG6	02	NG10	03	NG16	<table border="0" style="width: 100%;"> <thead> <tr> <th style="text-align: left;">Code</th> <th style="text-align: left;">Description</th> </tr> </thead> <tbody> <tr><td>1</td><td>Nitrile</td></tr> <tr><td>5</td><td>Fluorocarbon</td></tr> </tbody> </table>	Code	Description	1	Nitrile	5	Fluorocarbon
Code	Description																													
AA	Meter-out Control in A																													
AZ	Meter-in Control in A																													
BA	Meter-out Control in B																													
BB	Meter-in Control in B																													
ABA	Meter-out Control in A and B																													
ABZ	Meter-in Control in A and B																													
Code	Description																													
01	NG6																													
02	NG10																													
03	NG16																													
Code	Description																													
1	Nitrile																													
5	Fluorocarbon																													

<table border="0" style="width: 100%;"> <thead> <tr> <th style="text-align: left;">Code</th> <th style="text-align: left;">Description</th> </tr> </thead> <tbody> <tr><td>C</td><td>16</td></tr> <tr><td>D</td><td>06/10</td></tr> </tbody> </table>	Code	Description	C	16	D	06/10	<table border="0" style="width: 100%;"> <tr> <td style="text-align: right;"><b>Weight:</b></td> <td style="text-align: left;"><b>1 Cartridge</b></td> <td style="text-align: left;"><b>2 Cartridges</b></td> </tr> <tr> <td>ZRD*01</td> <td>1.2 kg (2.6 lbs)</td> <td>1.3 kg (2.9 lbs)</td> </tr> <tr> <td>ZRD*02</td> <td>2.8 kg (6.2 lbs.)</td> <td>2.9 kg (6.4 lbs.)</td> </tr> <tr> <td>ZDR*03</td> <td>7.4 kg (16.3 lbs.)</td> <td>7.7 kg (17.0 lbs.)</td> </tr> </table>	<b>Weight:</b>	<b>1 Cartridge</b>	<b>2 Cartridges</b>	ZRD*01	1.2 kg (2.6 lbs)	1.3 kg (2.9 lbs)	ZRD*02	2.8 kg (6.2 lbs.)	2.9 kg (6.4 lbs.)	ZDR*03	7.4 kg (16.3 lbs.)	7.7 kg (17.0 lbs.)	
Code	Description																			
C	16																			
D	06/10																			
<b>Weight:</b>	<b>1 Cartridge</b>	<b>2 Cartridges</b>																		
ZRD*01	1.2 kg (2.6 lbs)	1.3 kg (2.9 lbs)																		
ZRD*02	2.8 kg (6.2 lbs.)	2.9 kg (6.4 lbs.)																		
ZDR*03	7.4 kg (16.3 lbs.)	7.7 kg (17.0 lbs.)																		

**ZRD\*01**

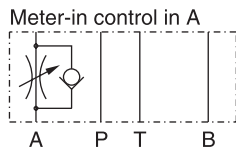

Series  
ZRD-AZ01-S0-D1

Order No.  
098-91056-0

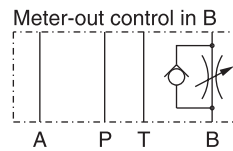

Series  
ZRD-BA01-S0-D1

Order No.  
098-91013-0

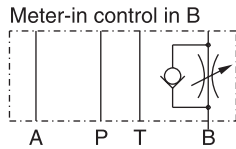

Series  
ZRD-BZ01-S0-D1

Order No.  
098-91057-0

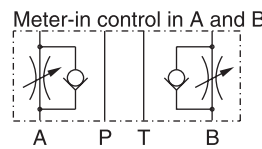

Series  
ZRD-ABZ01-S0-D1

Order No.  
098-91058-0

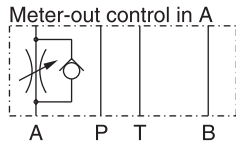

Series  
ZRD-AA01-S0-D1

Order No.  
098-91012-0

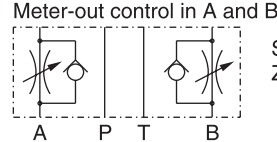

Series  
ZRD-ABA01-S0-D1

Order No.  
098-91014-0

**ZRD\*02 and ZRD\*03  
 (Continued on Next Page)**

**ZRD\*02**

Meter-in control in A

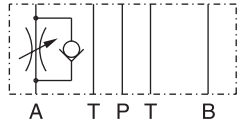

Series  
ZRD-AZ02-S0-D1

Order No.  
098-91059-0

Meter-out control in B



Series  
ZRD-BA02-S0-D1

Order no.  
098-91016-0

Meter-in control in B

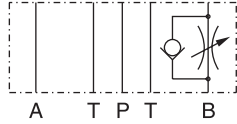

Series  
ZRD-BZ02-S0-D1

Order No.  
098-91060-0

Meter-in control in A and B

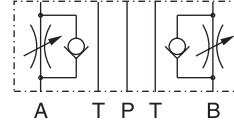

Series  
ZRD-BAZ02-S0-D1

Order no.  
098-91061-0

Meter-out control in A

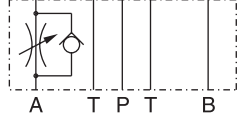

Series  
ZRD-AA02-S0-D1

Order no.  
098-91015-0

Meter-out control in A and B

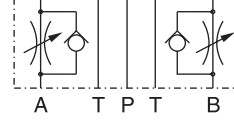

Series  
ZRD-ABA02-S0-D1

Order no.  
098-91017-0

**ZRD\*03**

Meter-in control in A

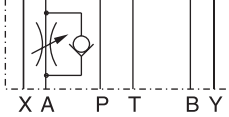

Series  
ZRD-AZ03-S0-C1

Order no.  
098-91422-0

Meter-out control in B

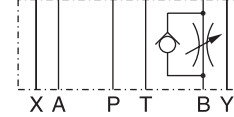

Series  
ZRD-BA03-S0-C1

Order no.  
098-91423-0

Meter-in control in B

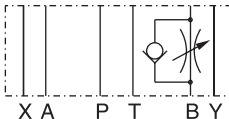

Series  
ZRD-BZ03-S0-C1

Order no.  
098-91424-0

Meter-in control in A and B

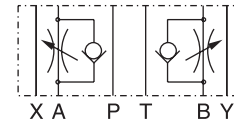

Series  
ZRD-ABZ03-S0-C1

Order no.  
098-91421-0

Meter-out control in A

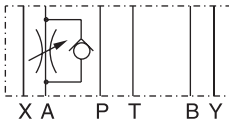

Series  
ZRD-AA03-S0-C1

Order no.  
098-91419-0

Meter-out control in A and B

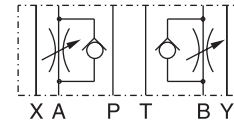

Series  
ZRD-ABA03-S0-C1

Order no.  
098-91420-0

**p/Q Performance Curves**

**ZRD\*01**

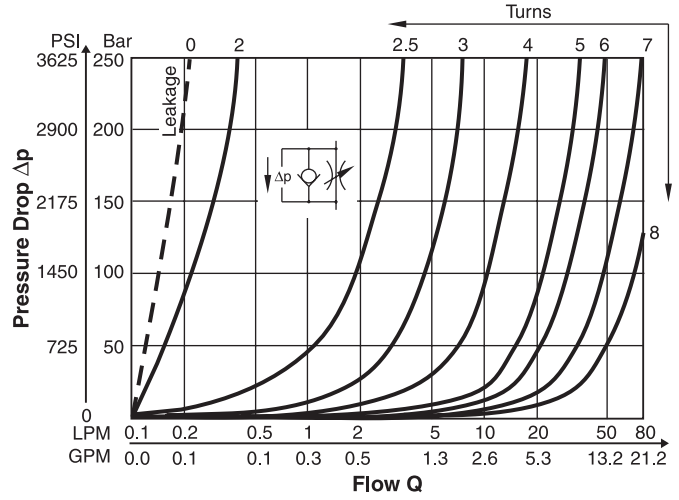
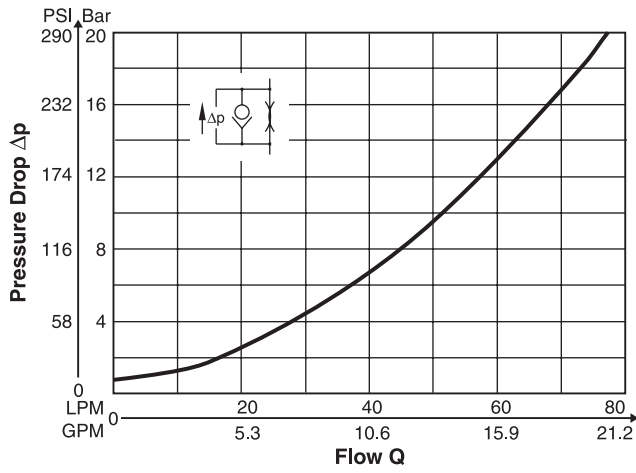

**ZRD\*02**

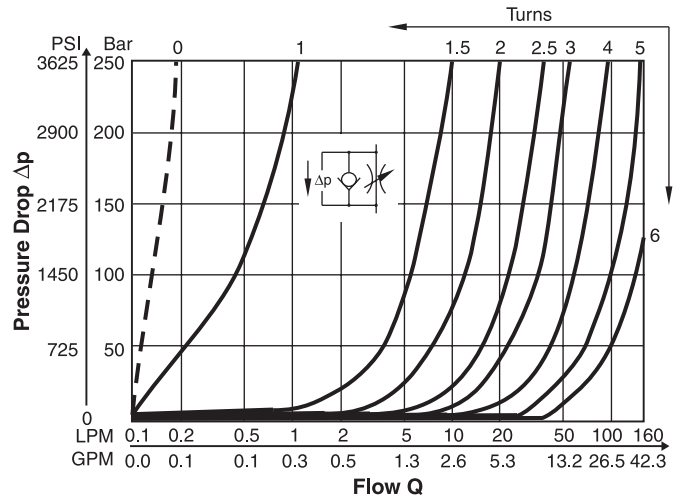
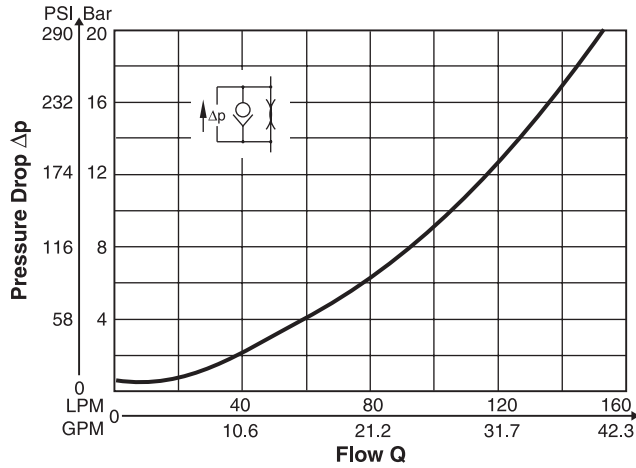

**ZRD\*03**

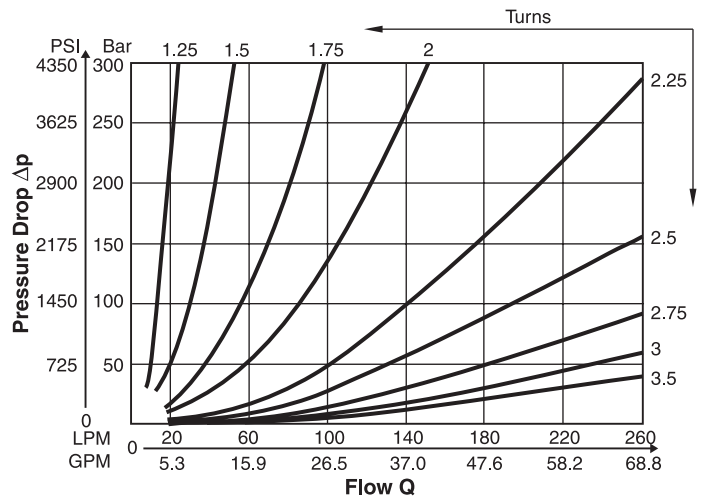
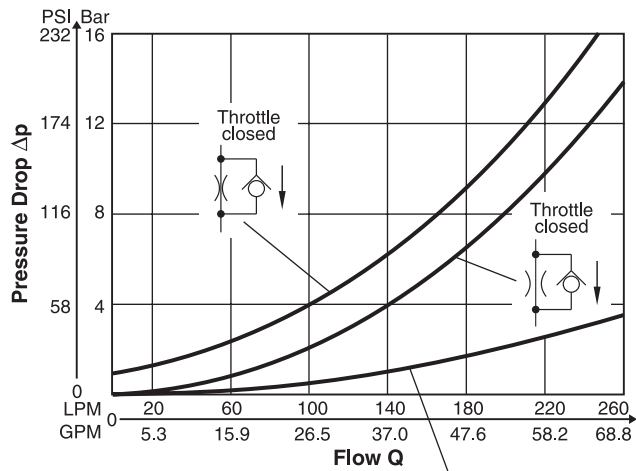

Pressure drop of return flow without throttle function  
 (for ZRD-AZ/BZ/AA/BA)

Fluid Viscosity 30 cSt @ 50°C (122°F)

ZRD.indd, dd



**Dimensions**

Inch equivalents for millimeter dimensions are shown in (\*\*)

**ZRD\*01**

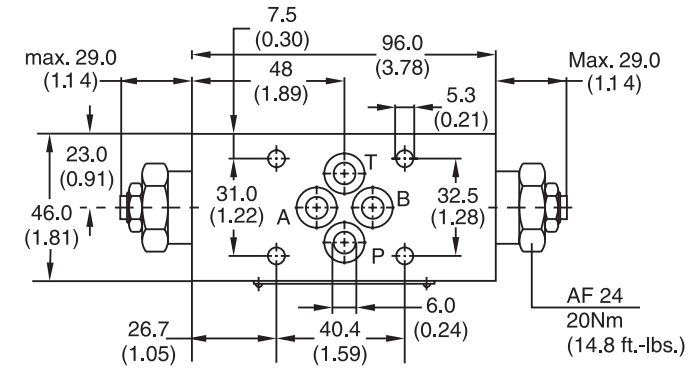

Seal Kit	
Seal	Order Code
1	098-91096-0
5	098-91097-0
Complete Cartridge	
Order Code	
098-91119-0	
O-ring Plate	
Order Code	
S26-27553-0	

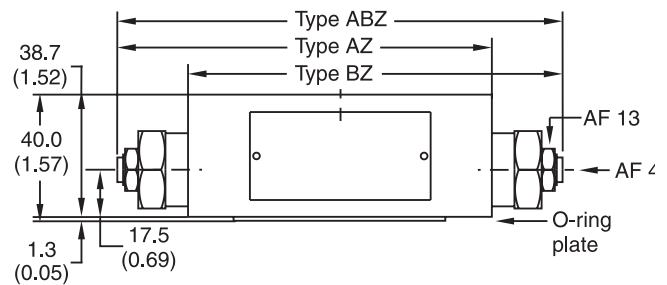
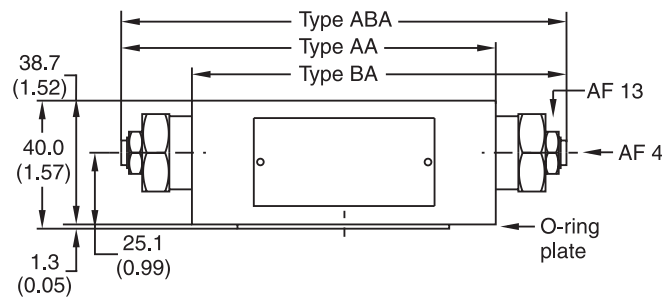

**ZRD\*02**

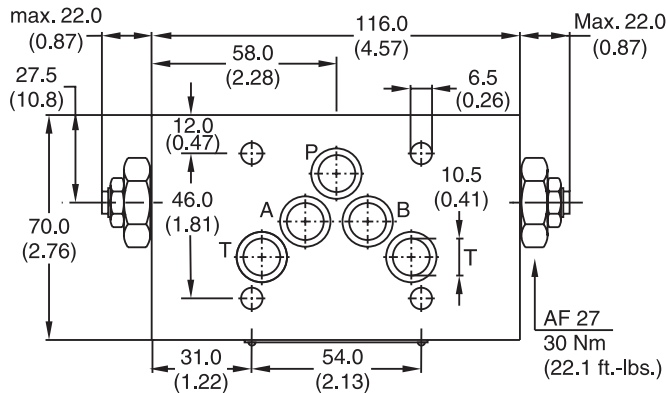

Seal Kit	
Seal	Order Code
1	098-91098-0
5	098-91099-0
Complete Cartridge	
Order Code	
098-91120-0	
O-ring Plate	
Order Code	
S16-85742-0	

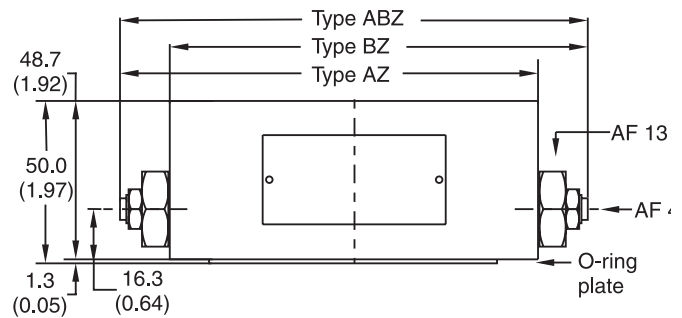
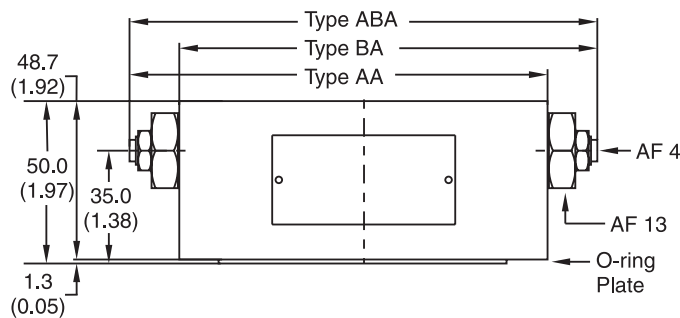

Inch equivalents for millimeter dimensions are shown in (\*\*)

**ZRD\*03**

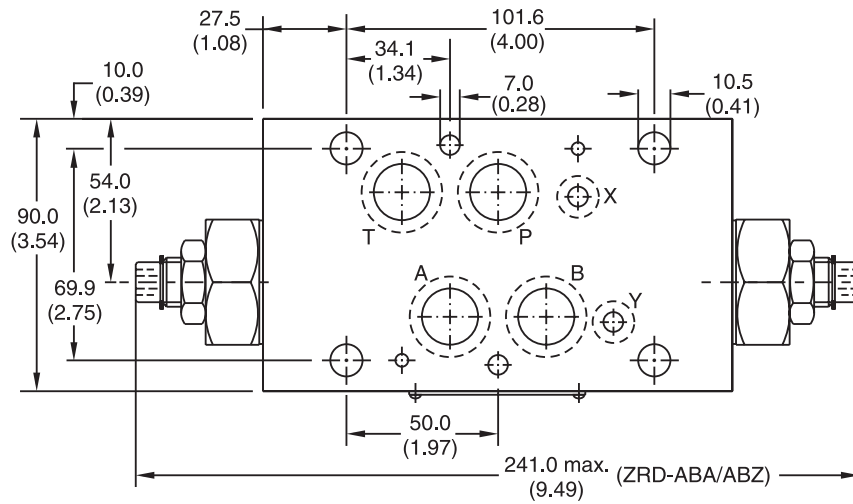

Seal Kit	
Seal	Order Code
1	098-91442-0
5	098-91443-0
Complete Cartridge	
Order Code	
098-91441-0	

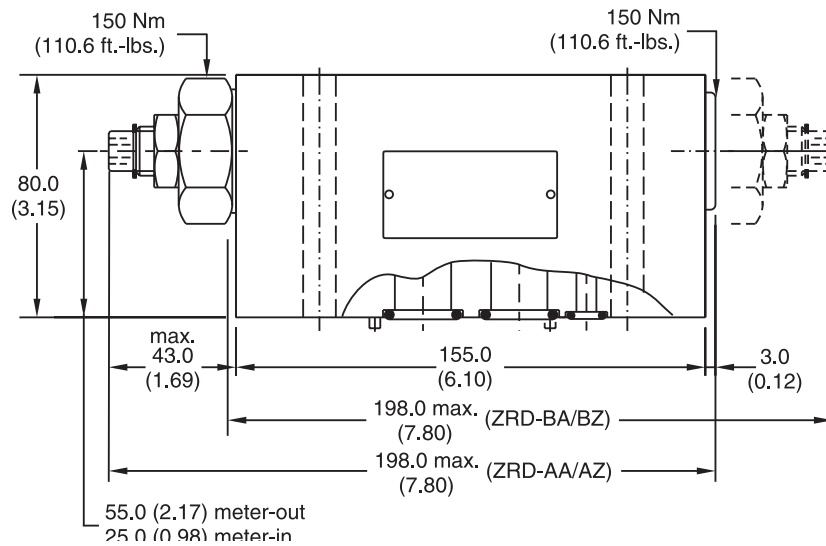

**General Description.**

Series ZRE pilot operated check valves are designed for maximum flow rates and long life time.

The valves are typically used in combination with spool type directional control valves to ensure leak free positioning of the actuator.

The inlet flow is free while the outlet flow is blocked. Pressure in the inlet line opens the check valve and allows free outlet flow.

**Features**

- High life time.
- Check function in A, B or A + B.
- Sizes
  - ZRE01 – NG06 / CETOP3
  - ZRE02 – NG10 / CETOP5
  - ZRE03 – NG16 / CETOP7

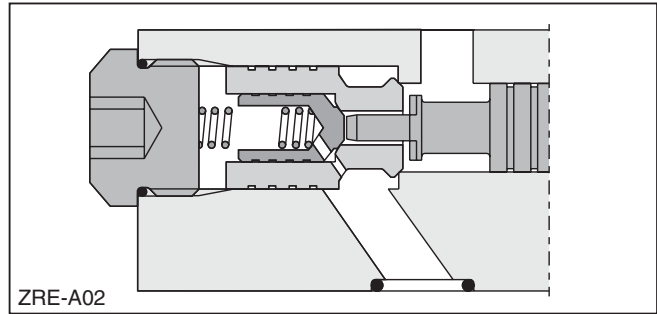
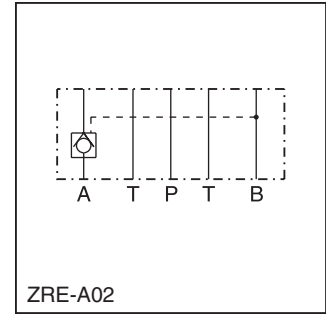

**Specifications**

General			
Size	NG6	NG10	NG16
Mounting Interface	DIN 24340 A6 ISO 4401 NFPA D03 CETOP RP 121	DIN 24340 A10 ISO 4401 NFPA D05 CETOP RP 121 5	DIN 24340 A16 ISO 4401 NFPA D08 CETOP RP 121
Mounting Position	Unrestricted		
Ambient Temperature	-20°C to +50°C (-4°F to +122°F)		
Hydraulic			
Max. Operating Pressure	350 Bar (5075 PSI)		
Nominal Flow	60 LPM (15.9 GPM)	120 LPM (31.7 GPM)	260 LPM (68.8 GPM)
Opening Ratio (Pilot Cone/Main Cone)	1:6	1:6	1:13
Cracking Pressure	1.2 Bar (17.4 PSI)	2.0 Bar (29.0 PSI)	2.0 Bar (29.0 PSI)
Fluid	Hydraulic oil in accordance with DIN 51524 ... 51525		
Fluid Temperature	-20°C to +80°C (-4°F to +176°F)		
Viscosity Permitted	10 to 650 cSt (mm <sup>2</sup> /s)		
Viscosity Recommended	30 cSt (mm <sup>2</sup> /s)		
Filtration	ISO 4406 (1999) 18/16/13 (acc. NAS 1638: 7)		

**ZRE**  
 Pilot Operated  
 Check Valve

Pressure  
 Control

Nominal  
 Size

Design  
 Series

Seals

Code	Description
A	Blocked in A
B	Blocked in B
AB	Blocked in A and B

Code	Description
01	NG6
02	NG10
03	NG16

Code	Description
C	16
D	06
E	10

Code	Description
1	Nitrile
5	Fluorocarbon

**Weight:**

ZRE\*01 1.2 kg (2.6 lbs)  
 ZRE\*02 3.1 kg (6.8 lbs.)  
 ZRE\*03 7.2/7.3 kg (15.9/16.1 lbs.)

**ZRE\*01**

blocked in A and B

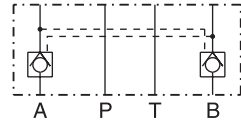

Series  
 ZRE-AB01-D1

Order No.  
 098-91020-0

blocked in A

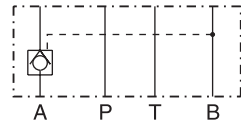

Series  
 ZRE-A01-D1

Order No.  
 098-91018-0

blocked in B



Series  
 ZRE-B01-D1

Order No.  
 098-91019-0

**ZRE\*02**

blocked in A and B

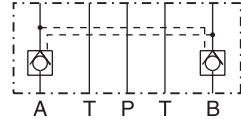

Series  
 ZRE-AB02-E1

Order No.  
 098-91300-0

blocked in A



Series  
 ZRE-A02-E1

Order No.  
 098-91298-0

blocked in B



Series  
 ZRE-B02-E1

Order No.  
 098-91304-0

**ZRE\*03**

blocked in A and B

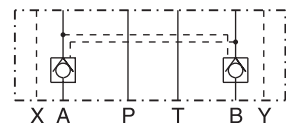

Series  
 ZRE-AB03-C1

Order No.  
 098-91426-0

blocked in A

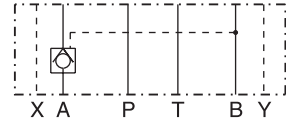

Series  
 ZRE-A03-C1

Order No.  
 098-91425-0

blocked in B

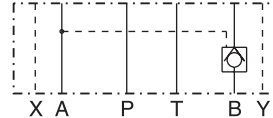

Series  
 ZRE-B03-C1

Order No.  
 098-91428-0

**p/Q Performance Curves**

**ZRE\*01**

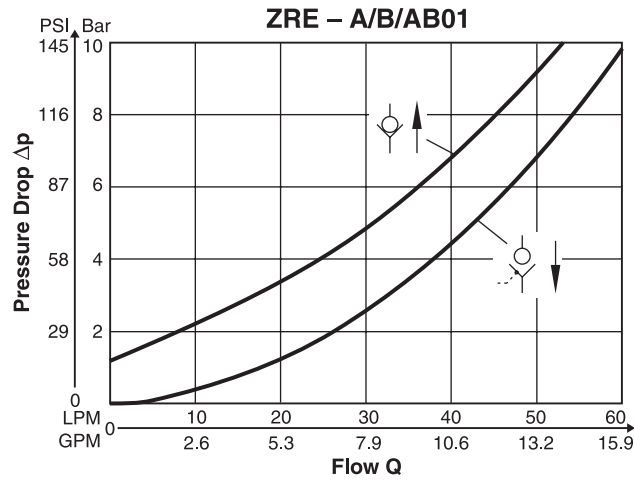

**ZRE\*02**

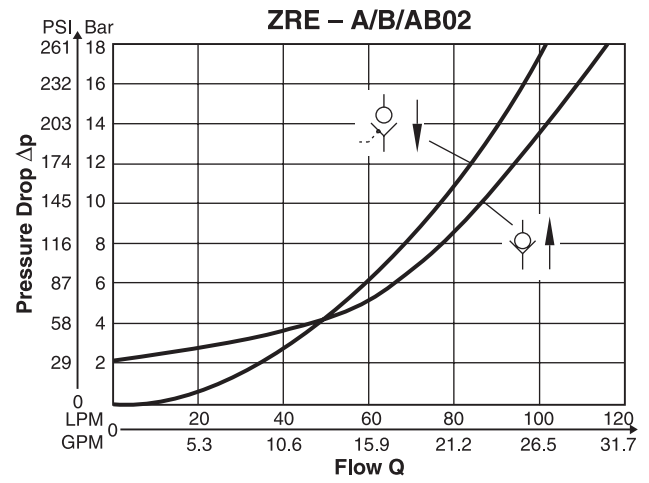

**ZRE\*03**

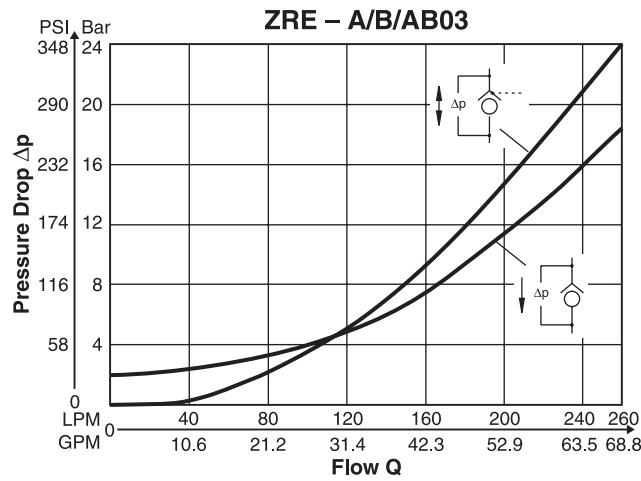

Fluid Viscosity 30 cSt at 50°C (122°F).

**Dimensions**

**Pilot Operated Check Valve  
Series ZRE**

Inch equivalents for millimeter dimensions are shown in (\*\*)

**ZRE\*01**

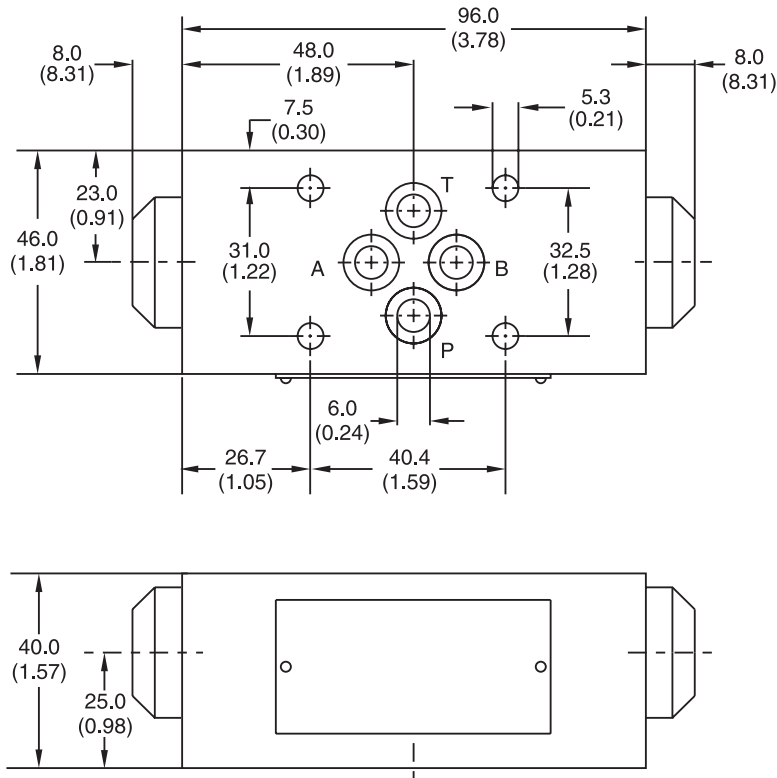

Seal Kit	
Seal	Order Code
1	098-91088-0
5	098-91089-0

**ZRE\*02**

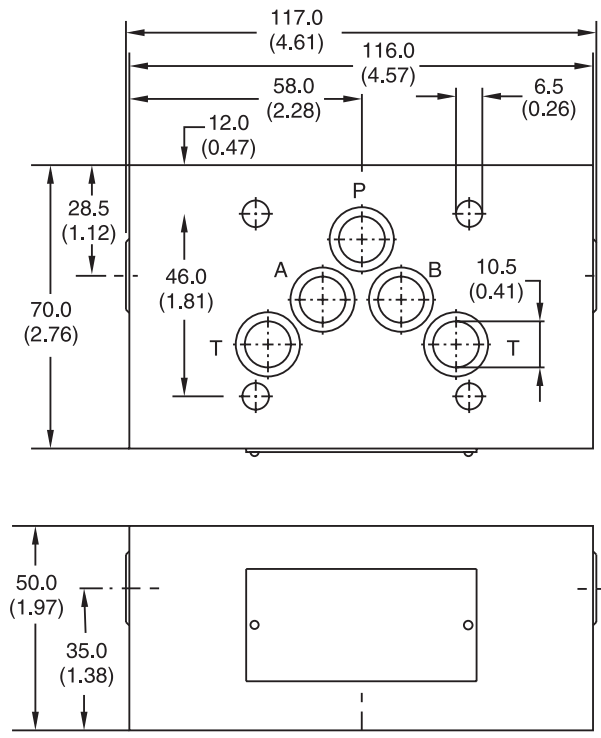

Seal Kit	
Seal	Order Code
1	098-91090-0
5	098-91091-0

Inch equivalents for millimeter dimensions are shown in (\*\*)

**ZRE\*03**

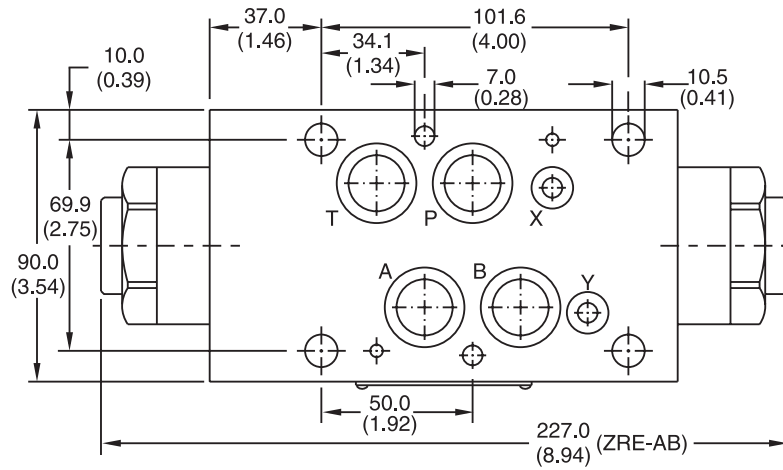

Seal Kit	
Seal	Order Code
1	098-91444-0
5	098-91445-0

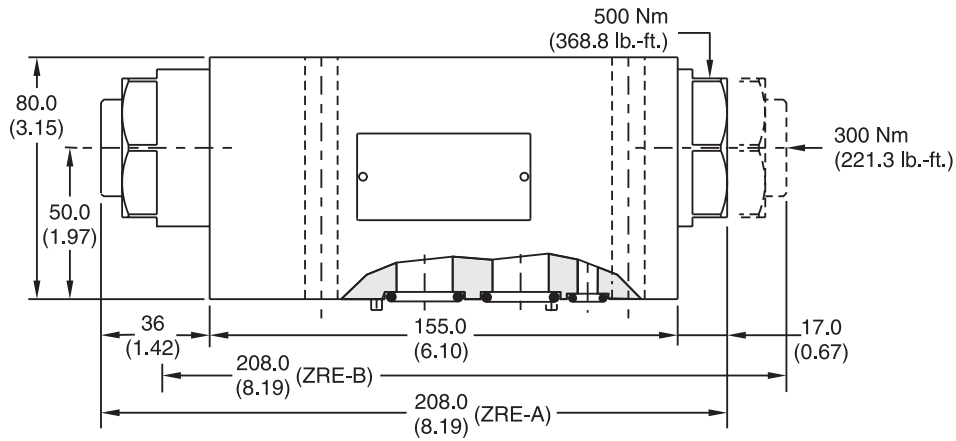

**General Description**

Series ZRV direct operated check valves have a cartridge type insert to provide zero leakage and high life time.

The check function can be located in the P- port or in the T-port.

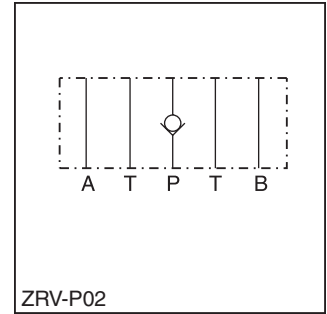

**Features**

- Leakage-free seat.
- High life time.
- Cracking pressure 0.5 Bar (7.25 PSI).
- Sizes
  - ZRV01 – NG06 / CETOP3
  - ZRV02 – NG10 / CETOP5

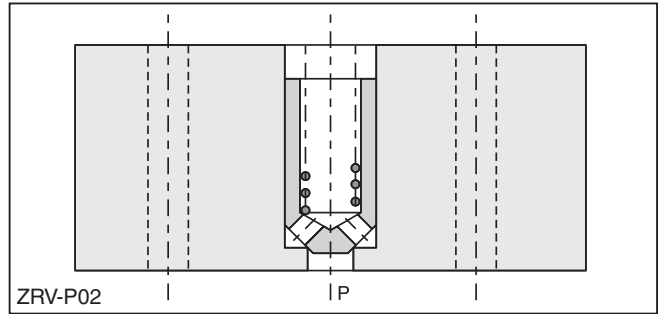

**Specifications**

General		
Size	NG6	NG10
Mounting Interface	DIN 24340 A6 ISO 4401 NFPA D03 CETOP RP 121	DIN 24340 A10 ISO 4401 NFPA D05 CETOP RP 121 5
Mounting Position	Unrestricted	
Ambient Temperature	-20°C to +50°C (-4°F to +122°F)	
Hydraulic		
Max. Operating Pressure	350 Bar (5075 PSI)	
Nominal Flow	40 LPM (10.6 GPM)	100 LPM (26.5 GPM)
Cracking Pressure	0.5 Bar (7.25 PSI)	0.5 Bar (7.25 PSI)
Fluid	Hydraulic oil as per DIN 51524 ... 51525	
Fluid Temperature	-20°C to +80°C (-4°F to +176°F)	
Viscosity Permitted	10 to 650 cSt (mm <sup>2</sup> /s)	
Viscosity Recommended	30 cSt (mm <sup>2</sup> /s)	
Filtration	ISO 4406 (1999) 18/16/13 (acc. NAS 1638: 7)	



**Ordering Information**

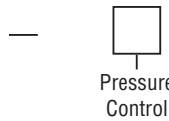

Code	Description
P	Blocked in P
T	Blocked in T

Code	Description
01	NG06
02	NG10

**Weight:**

ZRV\*01 0.7 kg (1.5 lbs)  
 ZRV\*02 2.0 kg (4.4 lbs.)

**ZRV\*01**

blocked in P

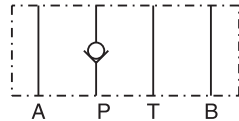

Series  
 ZRV-P01

Order No.  
 098-90025-0

blocked in T

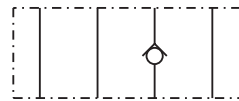

Series  
 ZRV-T01

Order No.  
 098-90026-0

**ZRV\*02**

blocked in P



Series  
 ZRV-P02

Order No.  
 098-90043-0

blocked in T

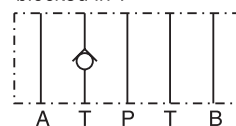

Series  
 ZRV-T02

Order No.  
 098-90044-0

**p/Q Performance Curves**

**ZRV\*01**

**ZRV – P/T01**

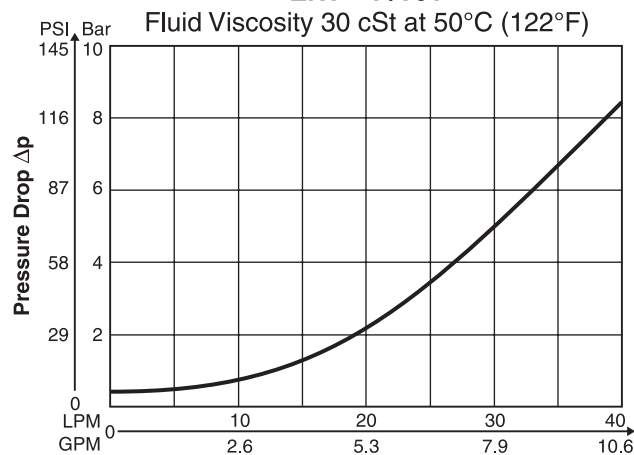

**ZRV\*02**

**ZRV – P/T02**

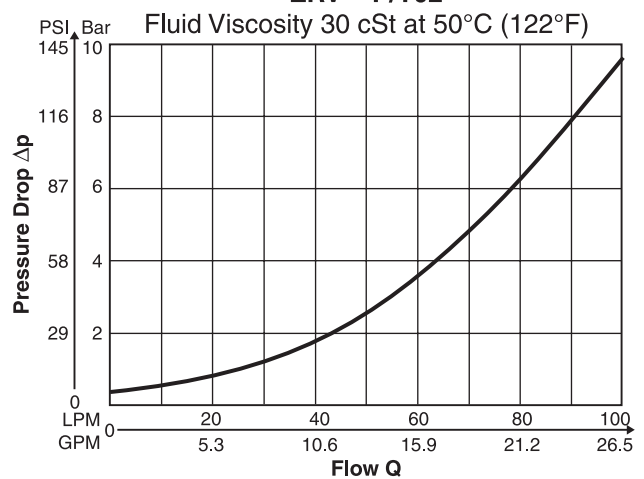

**Dimensions**

**Direct Operated Check Valve  
Series ZRV**

Inch equivalents for millimeter dimensions are shown in (\*\*)

**ZRV\*01**

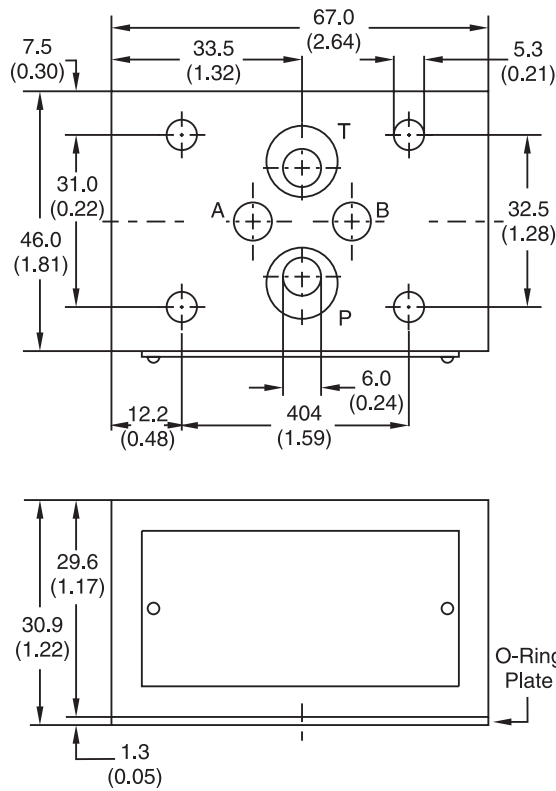

**ZRV\*02**

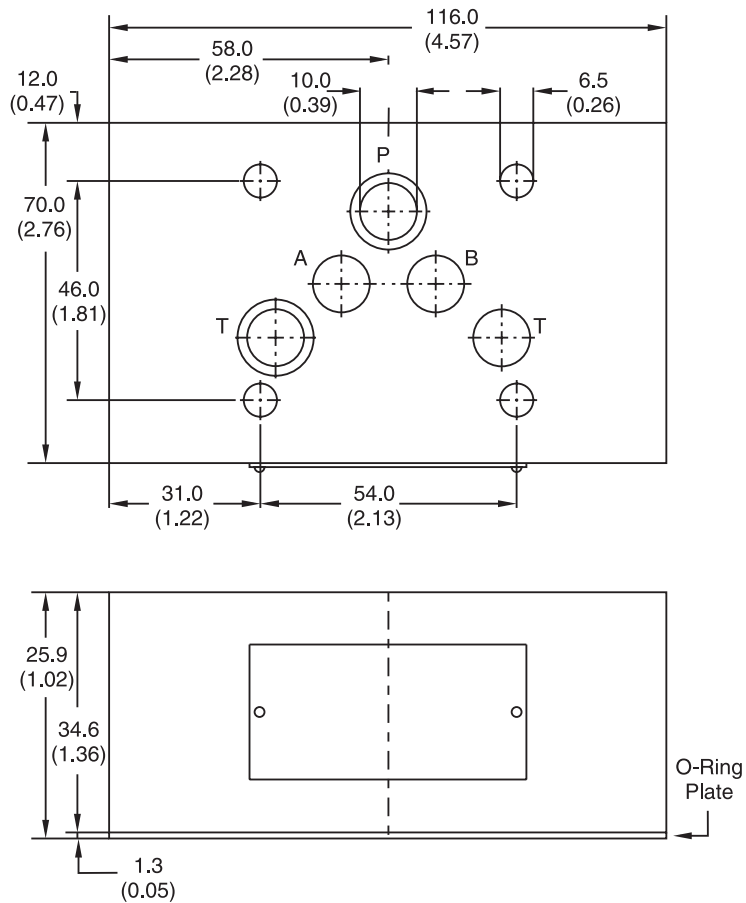

ZRV.indd, dd

## Welcome to Parker's Involvement Training Program

The Training Department at Parker Hannifin was established in the early 1970's and is recognized today as the industry leader in the development and presentation of training materials and programs.

The Department's charter states that the primary focus of activity shall include all phases of technical training for hydraulic and pneumatic industries. The charter also states that this would be non-commercial and involve state-of-the-art methodology.

The Parker approach is one of involvement training. In its full scope, involvement training is one of active participation. This participation results in excellent student retention as well as providing a comfortable way of learning.

Parker Catalog 0200 details the Training Department's current offerings. This catalog is presented in two parts: Training Materials and Training Programs.

### Training Materials

The training materials section contains the following mixed media components:

- Textbooks/Course Components
- Reference Books
- Computer Software
- Video Tapes
- Trainer Stands
- CD-ROMs

Parker offers seven textbook and course combinations designed for both industrial and educational applications. Topics range from Basic Fluid Power to the specifics of Hydraulic and Pneumatic Technology.

All materials needed for a complete classroom curriculum are available. Textbooks can be purchased separately or in combination with any number of additional course components including workbooks, instructor guide, multiple choice exams, answer book, course certificates and, where appropriate, digital transparencies and relevant reference books.

Parker currently has six reference books available. Led by the *Design Engineer's Handbook, Vol. 1 - Hydraulics*, all of the books are valuable tools for any Design Reference Library, whether for individual use or as an accompaniment to the courses.

Additionally, course subject matter can be further enhanced with related computer software, video tapes and trainer stands.

Parker's computer-aided software represents a strong commitment to advanced training technology. The *Industrial Hydraulic Training CD*, featuring animation and video, is the leading hydraulic computer based training program in the industrial market place.

The video tape library contains 14 complete modules for self-paced one-on-one or group learning activities. Both hydraulic and pneumatic training programs are available.

Parker's portable hydraulic, pneumatic trainer stands provide students with valuable hands-on experience. All training stands feature industrial grade components and provide "Real World" applications of principles and circuitry.

### Training Programs

In addition to training materials, Parker offers an ongoing schedule of classroom educational programs. The current list of classes includes ten 3-5 day programs. Each class is led by a Parker certified instructor(s). Students are provided all necessary materials to attain course certification.

Classes are held in strategic locations across North America and Europe. Download current training schedule for a complete list of scheduled class locations.

**Course fees cover all class room expenses. Meals, transportation and lodging are not included.**

However, Parker will be glad to assist you with lodging arrangements.

For the latest information on training materials or programs, please contact:

Parker Hannifin Corporation  
Training Department  
6035 Parkland Blvd.  
Cleveland, OH 44124-4141  
Tel: (216) 896-2495  
Fax: (216) 514-6738  
E-mail: [mctrain@parker.com](mailto:mctrain@parker.com)

or visit our website at:  
[www.parker.com/training](http://www.parker.com/training)

*The following section gives a brief overview of the training materials and classes with a hydraulic or electrohydraulic emphasis.*

## INDUSTRIAL HYDRAULIC



### **Industrial Hydraulic Technology**

*2nd Edition, Bulletin 0232-B1*

**ISBN 1-55769-025-1**

The *Industrial Hydraulic Technology* textbook is designed to introduce a student to hydraulics as it relates to industrial machinery. The 330-page text is organized into fifteen chapters which include:

*The Physical World of a Machine*  
*Hydraulic Transmission of Force and Energy*  
*Petroleum Base Hydraulic Fluid*  
*Fire Resistant Hydraulic Fluid*  
*Operation at the Suction Side of a Pump*  
*Hydraulic Actuators*  
*Control of Hydraulic Energy*  
*Check Valves, Accumulators and Cylinders*  
*Flow Control Valves*  
*Directional Control Valves*  
*Pressure Control Valves*  
*Pilot Operated Pressure Control Valves*  
*Hydraulic Pumps*  
*Hydraulic Motors*  
*Reservoirs, Coolers and Filters*

- Circuit illustrations are in six-color to aid the student in visualizing what is happening in a circuit.
- Each chapter incorporates an exercise reviewing the lesson's main points.

## HYDRAULIC MAINTENANCE TECHNOLOGY

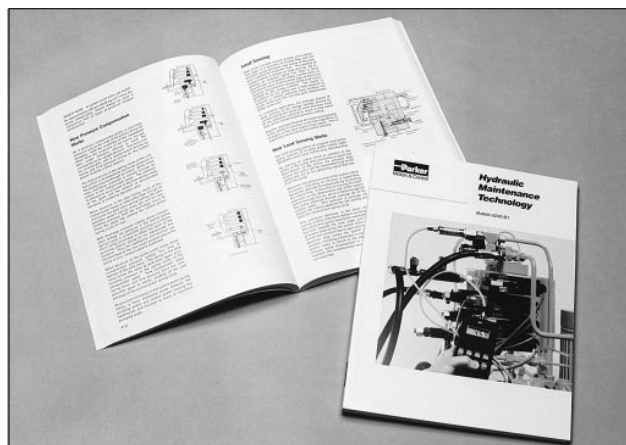

### **Hydraulic Maintenance Technology**

*Bulletin 0240-B1*

**ISBN 1-55769-019-7**

The *Hydraulic Maintenance Technology* textbook provides detailed maintenance and troubleshooting information for the user of industrial hydraulic equipment. The 148-page text contains ten chapters which include:

*Hydraulic Maintenance Introduction*  
*Hydraulic Graphic Symbology*  
*Power Unit Maintenance*  
*Pump Maintenance*  
*Pressure Control Valve Maintenance*  
*Directional Control Valve Maintenance*  
*Flow Control Valve and Check Valve Maintenance*  
*Cylinders, Motors and Accumulator Maintenance*  
*Leakage Elimination in Hydraulic Systems*  
*Fluids and Filter Maintenance*

- Contains troubleshooting charts with lists of common problems, causes and possible remedies.
- This text is also a valuable reference for designers of industrial hydraulic equipment

## FLUID POWER BASICS

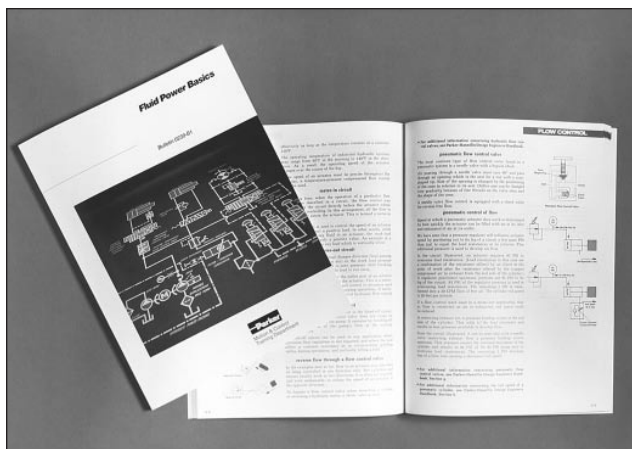

### **Fluid Power Basics**

**Bulletin 0239-B1**

**ISBN 1-55769-029-4**

The *Fluid Power Basics* textbook is designed to introduce students to hydraulics and pneumatics as it relates to industrial machinery. The 174-page text is organized into fifteen chapters which include:

*The Physical World of a Machine*  
*Force Transmission Through a Fluid*  
*Energy Transmission Using a Hydraulic System*  
*Control of Hydraulic Energy*  
*Energy Transmission Using a Pneumatic System*  
*Control of Pneumatic Energy*  
*Hydraulic Pumps and Compressors*  
*Check Valves, Cylinders and Motors*  
*Flow Control Valves*  
*Directional Control Valves*  
*Simple Pressure Control Valves*  
*Pilot Operated Pressure Control Valves*  
*Hydraulic Fluid Conditioning*  
*Air Preparation*  
*Fluid Conductors and Connectors*

- Each chapter incorporates an exercise reviewing the lesson's main points.

## FILTRATION TECHNOLOGY

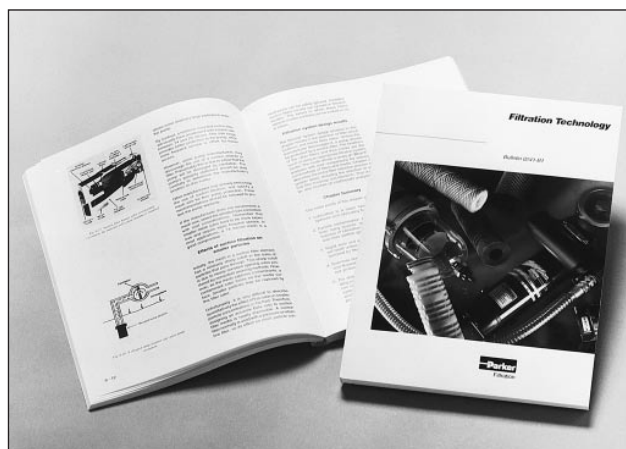

### **Filtration Technology, 2nd Edition**

**Bulletin 0247-B1 (Softcover)**

**ISBN 1-55769-030-8**

**Bulletin 0250-B1 (Hardcover, Not Shown)**

**ISBN 1-55769-033-2**

*Filtration Technology* is a must as a fundamental introduction to industrial filtration. The text covers topics such as fluids, contaminants, media selection and more. It is helpful to all personnel concerned with OSHA, safety and quality issues. This 250-page text is organized into twelve chapters which include:

*Introduction to Industrial Filtration Technology*  
*Fluids and Contaminants*  
*Contamination Dynamics*  
*Fluid and Filter Analysis*  
*Hydraulic Fluid Filter Selection*  
*Water Absorption in Hydraulic and Lubricating Oils*  
*Filter and Media Selection for Single-pass Systems*  
*Fuel Filtraion*  
*Process Filtration Systems*  
*Compressed Air and Gas Filtration*  
*Coolant Filtration*



## HYDRAULIC PUMPS & CONTROLS



### **Hydraulic Pumps & Controls**

***Bulletin 0238-B1***

***ISBN 1-55769-031-6***

Hydraulic Pumps and Controls is a comprehensive text covering relevant pump topics from basic pump construction and operation to multiple controls, horsepower control and electronic pump controls. The book also contains sections on filtration and troubleshooting. This 185-page, multi-colored text is organized into nine chapters which include:

*Pressure Compensation*

*Load Sensing Theory of Operation*

*Input Power and Inlet Conditions*

*Electrohydraulic Pump Control*

*Troubleshooting*

*Remote Compensation*

*Horsepower (Torque) Limiting Control*

*Hydraulic Filtration*

*Energy Conservation*

For information on Course Components, refer to Catalog 0200.

## Reference Books

### **Design Engineers Handbook**

***Bulletin 0292-B1 Volume 1 - Hydraulics***

***ISBN 1-55769-018-9***

To satisfy the demand for a simple and practical treatment of hydraulics and pneumatics, including components and system connectors, Parker Hannifin Corporation has published a one volume, 520-page text entitled *Design Engineers Handbook, Vol 1. - Hydraulics*. The information contained in this text is organized to assist the machine designer and manufacturer, as well as service and maintenance personnel. It should prove to be equally valuable to the college and vocational school student preparing to enter any of these fields.

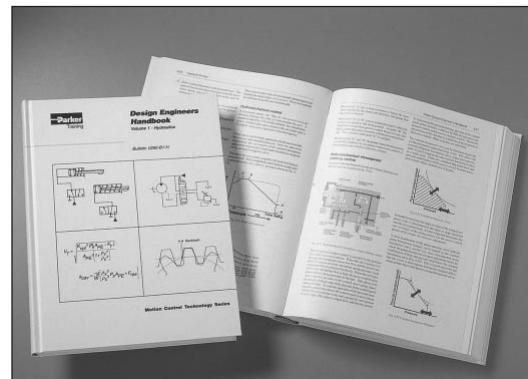

- Each section includes design data, reference material, charts and diagrams.

### **Handbook of Electrohydraulic Formulae, 2nd Edition**

**Bulletin 0242-B1**

**ISBN 1-55769-034-0**

This handbook, written for technicians, engineers and designers, contains 25 chapters of commonly used formulas for the design of electrohydraulic motion control systems. All of the necessary information is centralized, making the design of electrohydraulic motion control systems easier. There is no other text available that offers this accessibility or breadth and depth of information.

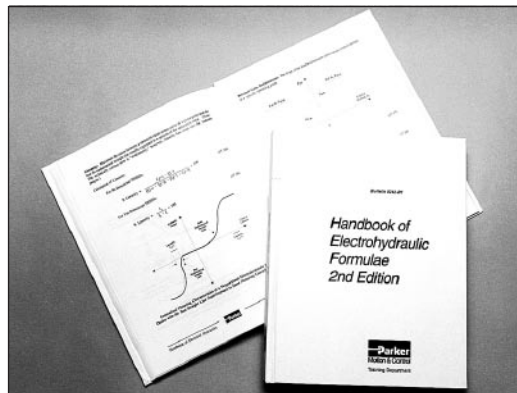

### **An Engineering Analysis of the Pulse Width Modulation**

**Bulletin 0244**

This research report contains over 100 pages of detailed engineering information and data regarding the design and evaluation of the pulse width modulation (PWM) method of controlling hydraulic pump outlet pressure. PWM offers a very efficient way for making regulated pressure power units using fixed displacement pumps instead of the more expensive, conventional pressure compensated pumps.

The report contains scores of graphical responses, representing hundreds of hours of labs and data analysis time. Concise Conclusions sections help the reader to quickly summarize the results and apply them immediately. A complete section is dedicated to Design Methodology so that users can learn the details needed to properly design and construct the power units.

Also included is a background on motion control and constant pressure. In addition, authors discuss equipment and principles of operation as well as the method of investigation used.

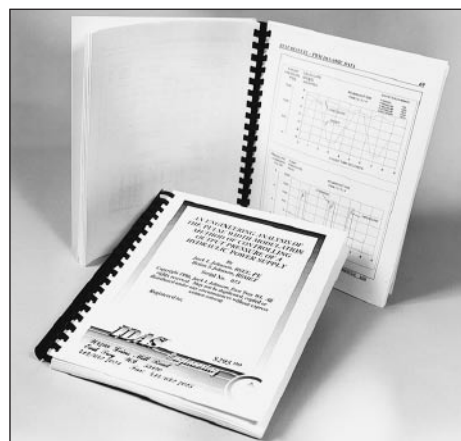

*An Engineering Analysis of the Pulse Width Modulation* is a must for anyone who uses, specifies, designs or builds hydraulic power units!

### **Lexicon III**

#### **Bulletin 0245**

The Lexicon III is a detailed bulletin of electrohydraulic terms and analogies. The book is laid out into two easy-to-use sections – a glossary of terms and a section on understanding electrohydraulic analogies. Many of the areas are represented by graphs and diagrams to further identify in detail the terms and analogies of electrohydraulics.

The author conveniently includes a chart of the SI prefixes, the Handy Conversions Factors Table and a listing of the Greek Letters. This bulletin is a must-have for engineers, students and anyone interested in electrohydraulics.

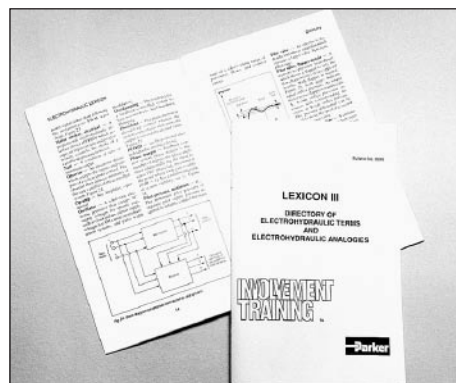

### **Video Tapes**

#### **Industrial Hydraulic Technology**

##### **Bulletin 0299-T1**

The *Industrial Hydraulic Technology* course material is available utilizing an audiovisual tape training method. With all the training information stored on cassette tapes, the training sessions can be repeated as often as necessary, allowing each student to acquire the technical knowledge at his or her own pace.

The various tapes focus on enabling the user to interpret and read schematics, obtain a working knowledge of components that make up hydraulic systems and advance to trouble shooting techniques. (Refer to page 4 to see specific chapters covered).

- Video tapes are available in Beta, VHS or PAL.
- Individual chapters are also available.



#### **Includes:**

- 14 Video Tapes
- 1 Textbook
- 1 Instructor's Guide



## Portable Hydraulic Trainer

Based on Parker's long term experience in designing, manufacturing and servicing fluidpower components worldwide, the Portable Hydraulic Trainer is designed to be a tool for learning hydraulic technology principles and circuitry. It has been engineered for ruggedness, portability and ease of operation. The unit is completely self-contained and operates on standard 115 Volt AC single phase outlet electrical power.

The components on the trainer are all industrial grade components used in industry every day. This "real world" approach allows the student to learn what those components look like as well as how they operate.

All necessary connections are made with hoses and quick disconnects. No tools are required to arrange circuits. Simply plug in the components needed to arrange a circuit. In addition, all the hoses are stored in a rack to avoid misplacing "loose" components.

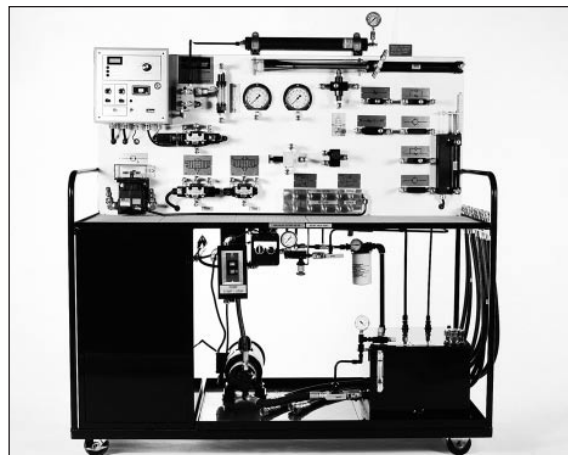

**For detailed information, see Bulletin 0203 online at [www.parker.com/training](http://www.parker.com/training) - click on Download Files**

Also available with the following options:

- **Electrohydraulic option** provides an introduction to both open loop and closed loop electrohydraulic systems.
- **Pneumatic option** transforms the hydraulic trainer into a complete fluidpower training stand.

## Bulletin 0249

In order to aid the student in understanding hydraulic components and systems operation, Parker has developed this comprehensive lab manual for the Model HTU-00 Portable Hydraulic Trainer Stand. This manual contains circuit problems and demonstrations designed for use with the Parker trainer. These exercises are intended to supplement text material covered in the classroom. References are made in this manual to Parker textbook, Industrial Hydraulic Technology (page L3).

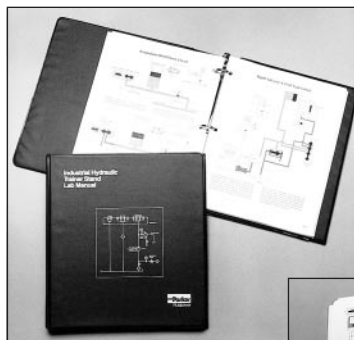

## EHD Supplement

**Bulletin 0231**

Contains exercises using the Electrohydraulic Option Kit (P/N 875279) on the Parker Portable Hydraulic Trainer Stand.

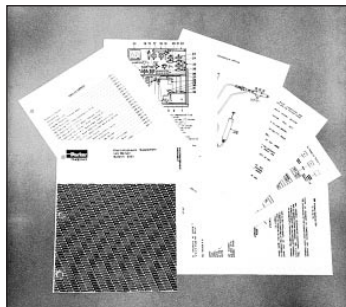

**Also available in Spanish!**  
**Bulletin 0229-B9**

## Industrial Hydraulic Technology 1 & 2



Parker Hannifin's **INDUSTRIAL HYDRAULIC TECHNOLOGY 1 & 2** (I.H.T. 1 & 2) are completely integrated three-day programs during which you discuss and work with fundamental fluid power principles and formulas, and actually experience the functional characteristics of the complete spectrum of hydraulic components.

You will be studying and using pumps, flow valves, pressure valves, directional valves, hydraulic motors, filters, cylinders and accumulators. And, because its divisions actually manufacture and market all of these products, Parker Hannifin is uniquely qualified to give you an in-depth practical knowledge of how to best use them in your field. You will receive the broadest and deepest exposure possible during a three-day period.

At least a fourth of the time you will be working at the Parker Hannifin hydraulic systems simulators. These units were designed and built by Parker Hannifin expressly for this program. They supply you with all the necessary components – valves, pumps, motors, cylinders, filters, power units, hoses and gauges – to hook up to working hydraulic circuits and then check flows, pressures and velocity. Unlike most other training apparatus, the Parker Hannifin simulators operate at pressures up to 500 psi so that you can closely simulate real system conditions.

The balance of your time will be devoted to classroom sessions. But, these too, are designed for maximum interest and involvement. There is plenty of lively discussion, questions, answers and practical problem solving.

## Hydraulic Maintenance Technology



**HYDRAULIC MAINTENANCE TECHNOLOGY** (H.M.T.) is ideally suited for maintenance personnel, engineers, first line supervisors and anyone desiring an in-depth understanding and appreciation of hydraulic system component operation and troubleshooting techniques. Participants should have completed the **INDUSTRIAL HYDRAULIC TECHNOLOGY** course or equivalent.

The topics covered in this four-day program are graphic symbols of hydraulic components in which we utilize the International Standards Organization (ISO) System; troubleshooting common hydraulic components such as pumps, cylinders, valves, rotary actuators,

hydraulic motors; hose and tube fittings maintenance and assembly; and maintenance of fluid power systems.

There is plenty of “hands on” in this particular course. Everyone will get a chance to take apart and reassemble various pumps and valves as well as other typical hydraulic components.

## Mobile Hydraulic Technology



**MOBILE HYDRAULIC TECHNOLOGY** (M.H.T.) is a 4-day course on hydraulic principles as they apply to mobile equipment (loggers, waste hauling trucks, cranes, etc.).

Such topics as basic mobile circuitry, hydrostatic transmissions and power beyond are discussed throughout the course. Components – directional control valves, pumps and steering systems – are also covered. Labs include a demo on a wheel motor driving a rubber tire.

**MOBILE HYDRAULIC TECHNOLOGY** is recommended for maintenance technicians and engineering. Sales and non-technical personnel wishing to increase their understanding of mobile hydraulics would find this class helpful.

## Introduction to Electrohydraulics



The **INTRODUCTION TO ELECTROHYDRAULICS (E.H.D.)** course is designed for the individual who requires an increased understanding of the rapidly emerging field of electrohydraulic proportional control valves and the electronics used to operate these valves. The individual must have completed the **INDUSTRIAL HYDRAULIC TECHNOLOGY** and **HYDRAULIC COMPONENT SIZING** courses or equivalent. Basic DC theory knowledge is helpful but not necessary as the topic is covered in the course.

In this five-day course we present fundamental electronic theory applicable to electrohydraulic proportional valve; help participants understand how electrohydraulic proportional valves operate; examine in detail a typical circuit board used with a typical electrohydraulic proportional valve.

Approximately 30% of the class time is spent in the lab where the individual is familiarized with lab instrumentation, and various circuits on the printed circuit board are examined in detail.

## Hydraulic Component Sizing



**HYDRAULIC COMPONENT SIZING (H.C.S.)** is ideally suited for the new designer and the maintenance and service individual who needs that important step beyond fundamental circuit design; the step that provides a more comprehensive understanding of efficient power transmission.

This program, using standard formulas and catalog data creates a benchmark that allows the student to objectively analyze the quality of the circuit in terms of efficiency and energy conservation. You will learn how to overcome problem areas and also become aware of the proper conditions for selecting components such as pressure compensated valves and fixed versus compensated pumps.

Parker Hannifin has written a special textbook for this course, which you will use during the program as the basis for your discussions and practical problem solving.

Since **HYDRAULIC COMPONENT SIZING** is an analytical course, we want to insure that all participants have a solid relatively equal background in basic fluid power technology. Completion of Parker Hannifin's **INDUSTRIAL HYDRAULIC TECHNOLOGY** course is an ideal foundation for understanding and further pursuing the maximum energy savings approach that is key to the **HYDRAULIC COMPONENT SIZING** subject matter.

## Electrohydraulic Feedback Systems

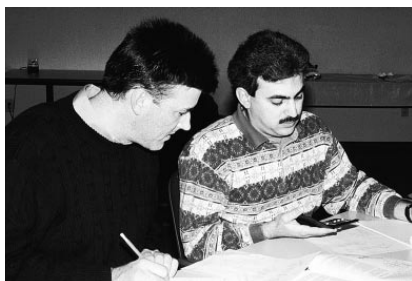

Parker's **ELECTROHYDRAULIC FEEDBACK SYSTEMS (E.F.S.)** course is designed for engineering oriented individuals requiring an in-depth understanding of electrohydraulic feedback control systems. Attendees should have completed the Parker **INTRODUCTION TO ELECTROHYDRAULICS** prior to attending this advanced course.

The following topics are covered in this course: servo valve sizing, basic positional servo valve systems, position transducers, speed transducers, frequency response curves, transfer functions and speed control loops.

Approximately 20% of the class time spent is in the lab working with various feedback control systems to gain a better understanding of their operating characteristics.



## Terms of Sale with Warranty Limitations

### Offer of Sale

The items described in this document and other documents or descriptions provided by Parker Hannifin Corporation, its subsidiaries and its authorized distributors are hereby offered for sale at prices to be established by Parker Hannifin Corporation, its subsidiaries and its authorized distributors. This offer and its acceptance by any customer ("Buyer") shall be governed by all of the following Terms and Conditions. Buyer's order for any such items, when communicated to Parker Hannifin Corporation, its subsidiary or an authorized distributor ("Seller") verbally or in writing, shall constitute acceptance of this offer.

**1. Terms and Conditions of Sale:** All descriptions, quotations, proposals, offers, acknowledgments, acceptances and sales of Seller's products are subject to and shall be governed exclusively by the terms and conditions stated herein. Buyer's acceptance of any offer to sell is limited to these terms and conditions. Any terms or conditions in addition to, or inconsistent with those stated herein, proposed by Buyer in any acceptance of an offer by Seller, are hereby objected to. No such additional, different or inconsistent terms and conditions shall become part of the contract between Buyer and Seller unless expressly accepted in writing by Seller. Seller's acceptance of any offer to purchase by Buyer is expressly conditional upon Buyer's assent to all the terms and conditions stated herein, including any terms in addition to, or inconsistent with those contained in Buyer's offer. Acceptance of Seller's products shall in all events constitute such assent.

**2. Payment:** Payment shall be made by Buyer net 30 days from the date of delivery of the items purchased hereunder. Amounts not timely paid shall bear interest at the maximum rate permitted by law for each month or portion thereof that the Buyer is late in making payment. Any claims by Buyer for omissions or shortages in a shipment shall be waived unless Seller receives notice thereof within 30 days after Buyer's receipt of the shipment.

**3. Delivery:** Unless otherwise provided on the face hereof, delivery shall be made F.O.B. Seller's plant. Regardless of the method of delivery, however, risk of loss shall pass to Buyer upon Seller's delivery to a carrier. Any delivery dates shown are approximate only and Seller shall have no liability for any delays in delivery.

**4. Warranty:** Seller warrants that the items sold hereunder shall be free from defects in material or workmanship for a period of 18 months from date of shipment from Parker Hannifin Corporation. **THIS WARRANTY COMPRISES THE SOLE AND ENTIRE WARRANTY PERTAINING TO ITEMS PROVIDED HEREUNDER. SELLER MAKES NO OTHER WARRANTY, GUARANTEE, OR REPRESENTATION OF ANY KIND WHATSOEVER. ALL OTHER WARRANTIES, INCLUDING BUT NOT LIMITED TO, MERCHANTABILITY AND FITNESS FOR PURPOSE, WHETHER EXPRESS, IMPLIED, OR ARISING BY OPERATION OF LAW, TRADE USAGE, OR COURSE OF DEALING ARE HEREBY DISCLAIMED. NOTWITHSTANDING THE FOREGOING, THERE ARE NO WARRANTIES WHATSOEVER ON ITEMS BUILT OR ACQUIRED WHOLLY OR PARTIALLY, TO BUYER'S DESIGNS OR SPECIFICATIONS.**

**5. Limitation Of Remedy: SELLER'S LIABILITY ARISING FROM OR IN ANY WAY CONNECTED WITH THE ITEMS SOLD OR THIS CONTRACT SHALL BE LIMITED EXCLUSIVELY TO REPAIR OR REPLACEMENT OF THE ITEMS SOLD OR REFUND OF THE PURCHASE PRICE PAID BY BUYER, AT SELLER'S SOLE OPTION. IN NO EVENT SHALL SELLER BE LIABLE FOR ANY INCIDENTAL, CONSEQUENTIAL OR SPECIAL DAMAGES OF ANY KIND OR NATURE WHATSOEVER, INCLUDING BUT NOT LIMITED TO LOST PROFITS ARISING FROM OR IN ANY WAY CONNECTED WITH THIS AGREEMENT OR ITEMS SOLD HEREUNDER, WHETHER ALLEGED TO ARISE FROM BREACH OF CONTRACT, EXPRESS OR IMPLIED WARRANTY, OR IN TORT, INCLUDING WITHOUT LIMITATION, NEGLIGENCE, FAILURE TO WARN OR STRICT LIABILITY.**

**6. Changes, Reschedules and Cancellations:** Buyer may request to modify the designs or specifications for the items sold hereunder as well as the quantities and delivery dates thereof, or may request to cancel all or part of this order, however, no such requested modification or cancellation shall become part of the contract between Buyer and Seller unless accepted by Seller in a written amendment to this Agreement. Acceptance of any such requested modification or cancellation shall be at Seller's discretion, and shall be upon such terms and conditions as Seller may require.

**7. Special Tooling:** A tooling charge may be imposed for any special tooling, including without limitation, dies, fixtures, molds and patterns, acquired to manufacture items sold pursuant to this contract. Such special tooling shall be and remain Seller's property notwithstanding payment of any charges by Buyer. In no event will Buyer acquire any interest in apparatus belonging to Seller which is utilized in the manufacture of the items sold hereunder, even if such apparatus has been specially converted or adapted for such manufacture and notwithstanding any charges paid by Buyer. Unless otherwise agreed, Seller shall have the right to alter,

discard or otherwise dispose of any special tooling or other property in its sole discretion at any time.

**8. Buyer's Property:** Any designs, tools, patterns, materials, drawings, confidential information or equipment furnished by Buyer or any other items which become Buyer's property, may be considered obsolete and may be destroyed by Seller after two (2) consecutive years have elapsed without Buyer placing an order for the items which are manufactured using such property. Seller shall not be responsible for any loss or damage to such property while it is in Seller's possession or control.

**9. Taxes:** Unless otherwise indicated on the face hereof, all prices and charges are exclusive of excise, sales, use, property, occupational or like taxes which may be imposed by any taxing authority upon the manufacture, sale or delivery of the items sold hereunder. If any such taxes must be paid by Seller or if Seller is liable for the collection of such tax, the amount thereof shall be in addition to the amounts for the items sold. Buyer agrees to pay all such taxes or to reimburse Seller therefore upon receipt of its invoice. If Buyer claims exemption from any sales, use or other tax imposed by any taxing authority, Buyer shall save Seller harmless from and against any such tax, together with any interest or penalties thereon which may be assessed if the items are held to be taxable.

**10. Indemnity For Infringement of Intellectual Property Rights:** Seller shall have no liability for infringement of any patents, trademarks, copyrights, trade dress, trade secrets or similar rights except as provided in this Part 10. Seller will defend and indemnify Buyer against allegations of infringement of U.S. Patents, U.S. Trademarks, copyrights, trade dress and trade secrets (hereinafter 'Intellectual Property Rights'). Seller will defend at its expense and will pay the cost of any settlement or damages awarded in an action brought against Buyer based on an allegation that an item sold pursuant to this contract infringes the Intellectual Property Rights of a third party. Seller's obligation to defend and indemnify Buyer is contingent on Buyer notifying Seller within ten (10) days after Buyer becomes aware of such allegations of infringement, and Seller having sole control over the defense of any allegations or actions including all negotiations for settlement or compromise. If an item sold hereunder is subject to a claim that it infringes the Intellectual Property Rights of a third party, Seller may, at its sole expense and option, procure for Buyer the right to continue using said item, replace or modify said item so as to make it noninfringing, or offer to accept return of said item and return the purchase price less a reasonable allowance for depreciation. Notwithstanding the foregoing, Seller shall have no liability for claims of infringement based on information provided by Buyer, or directed to items delivered hereunder for which the designs are specified in whole or part by Buyer, or infringements resulting from the modification, combination or use in a system of any item sold hereunder. The foregoing provisions of this Part 10 shall constitute Seller's sole and exclusive liability and Buyer's sole and exclusive remedy for infringement of Intellectual Property Rights.

If a claim is based on information provided by Buyer or if the design for an item delivered hereunder is specified in whole or in part by Buyer, Buyer shall defend and indemnify Seller for all costs, expenses or judgments resulting from any claim that such item infringes any patent, trademark, copyright, trade dress, trade secret or any similar right.

**11. Force Majeure:** Seller does not assume the risk of and shall not be liable for delay or failure to perform any of Seller's obligations by reason of circumstances beyond the reasonable control of Seller (hereinafter 'Events of Force Majeure'). Events of Force Majeure shall include without limitation, accidents, acts of God, strikes or labor disputes, acts, laws, rules or regulations of any government or government agency, fires, floods, delays or failures in delivery of carriers or suppliers, shortages of materials and any other cause beyond Seller's control.

**12. Entire Agreement/Governing Law:** The terms and conditions set forth herein, together with any amendments, modifications and any different terms or conditions expressly accepted by Seller in writing, shall constitute the entire Agreement concerning the items sold, and there are no oral or other representations or agreements which pertain thereto. This Agreement shall be governed in all respects by the law of the State of Ohio. No actions arising out of the sale of the items sold hereunder or this Agreement may be brought by either party more than two (2) years after the cause of action accrues.

9/91-P

terms-safety.indd, dd





## Parker Safety Guide for Selecting and Using Hydraulic Valves and Related Accessories

**WARNING:** Failure or improper selection or improper use of Parker Hydraulic Valve Division (HVD) Valves or related accessories (“Products”) can cause death, personal injury and property damage. Possible consequences of failure or improper use of these Products include but are not limited to:

- Valves or parts thereof thrown off at high speed
- High velocity fluid discharge
- Explosion or burning of the conveyed fluid
- Contact with suddenly moving or falling objects controlled by the Valve
- Injections by high-pressure fluid discharge
- Contact with fluid that may be hot, cold, toxic or otherwise injurious
- Injuries resulting from injection, inhalation or exposure to fluids
- Injury from handling a heavy item (dropped, awkward lift)
- Electric shock from improper handling of solenoid connections
- Injury from slip or fall on spilled or leaked fluid

Before selecting or using any of these Products, it is important that you read and follow the instructions below. In general, the Products are not approved for in-flight aerospace applications. Consult the factory for the few that are FAA approved.

### 1.0 GENERAL INSTRUCTIONS

- 1.1 **Scope:** This safety guide provides instructions for selecting and using (including assembling, installing and maintaining) these Products. For convenience all items in this guide are called “Valves”. This safety guide is a supplement to and is to be used in conjunction with the specific Parker catalogs for the specific Valves and/or accessories being considered for use. See item 1.6 below for obtaining those catalogs.
- 1.2 **Fail-Safe:** Valves can and do fail without warning for many reasons. Design all systems and equipment in a fail-safe mode, so that failure of the Valve or Valve Assembly will not endanger persons or property.
- 1.3 **Safety Devices:** Never disconnect, override, circumvent or otherwise disable any safety lockout on any system whether powered by HVD Valves or any motion control system of any manufacturer. (e.g. Automatic shut-off on a riding lawn mower should the operator get out of the seat).
- 1.4 **Distribution:** Provide a copy of this safety guide to each person that is responsible for selecting or using HVD Valve Products. Do not select HVD Valves without thoroughly reading and understanding this safety guide as well as the specific Parker catalogs for the Products considered or selected.
- 1.5 **User Responsibility:** Due the wide variety of operating conditions and applications for Valves, HVD and its distributors do not represent or warrant that any particular Valve is suitable for any specific system. This safety guide does not analyze all technical parameters that must be considered in selecting a product. The user, through its own analysis and testing is solely responsible for:
  - Making the final selection of the Valve
  - Assuring that the user’s requirements are met and that the application presents no health or safety hazards.
  - Providing all appropriate health and safety warnings on the equipment on which the Valves are used.
  - Assuring compliance with all applicable government and industry standards.
- 1.6 **Additional Questions:** Call the appropriate Parker technical service department if you have any questions or require any additional information. See the Parker publication for the product being considered or used, or call 1-800-CPARKER, or go to [www.parker.com](http://www.parker.com), for the telephone numbers of the appropriate technical service department. For additional copies of this or any other Parker Safety Guide go to [www.parker.com](http://www.parker.com) and click on the safety button on the opening page. Catalogs and/or catalog numbers for the various HVD Valve Products can be obtained by calling HVD at 440-366-5100. Phone numbers and catalog information is also available on the Parker website, [www.parker.com](http://www.parker.com).

### 2.0 VALVE SELECTION INSTRUCTIONS

- 2.1 **Pressure:** Valve selection must be made so that the maximum working pressure of the Valve is equal to or greater than the maximum system pressure. Surge, impulse or peak transient pressures in the system must be below the maximum working pressure of the Valve. Surge, impulse and peak pressures can usually be determined by sensitive electrical instrumentation that measures and indicates pressures at millisecond intervals. Mechanical pressure gauges indicate only average pressure and cannot be used to determine surge, impulse or peak transient pressures. Burst pressure ratings if given or known are for manufacturing purposes only and are not an indication that the Product can be used in applications at the burst pressure or otherwise above the maximum working pressure.
- 2.2 **Temperature:** The fluid temperature must be regulated or controlled so that the operating viscosity of the fluid is maintained at a level specified for the particular Valve product. Such ranges are given in the product catalogs or can be obtained from the appropriate customer service department for the particular Valve product.
- 2.3 **Fluid Compatibility:** The fluid conveyed in Valves has direct implications on the Valve selection. The fluid must be chemically compatible with the Valve component materials. Elastomer seals, brass, cast iron, aluminum for example all are potentially affected by certain fluids. Additionally, fluid selection affects the performance of various Valves. Considerations relative to fluid selection are outlined in the specific HVD Valve product catalog. Of particular importance is that the fluid be for hydraulic use, contain the proper additives and wear inhibitors. See 1.6 “Additional Questions” above for information to obtain such HVD catalogs.
- 2.4 **Changing Fluids:** If a system requires a different fluid, it should be done with the guidance in number 2.3 above. Additionally, it may be necessary to flush the system (including the Valves) to remove any of the previous fluid. Consult the Parker Valve Division for guidance.
- 2.5 **Size:** Transmission of power by means of pressurized fluid varies with pressure and rate of flow. The size of the components must be adequate to keep pressure losses to a minimum and avoid damage due to heat generation or excessive fluid velocity.
- 2.6 **Placement:** Installation of Valves must take into account the orientation of the Valve and the proximity of the Valve to other parts of the system. This includes but is not limited to closeness to hot and cold areas, access for servicing and operation as well as orientation for proper connectors.
- 2.7 **Ports:** Connection of Valves in systems can be by threaded ports, sub-base surfaces, flanges and manifolds. In all cases, the proper fitting, surface or mounting hardware must be selected to properly seal and contain the system fluid so as to avoid the adverse conditions listed in the initial warning box above. Specifically, if using threaded ports, the designer must make sure that the mating fitting is of the compatible thread. Also, the instructions provided by the connector hardware supplier must be read and understood so as to properly assemble the connector. The Parker Safety Guide for using Hose, Tubing and Fittings and Related Accessories is but one reference to this end.
- 2.8 **Environment:** Care must be taken to insure that the Valve and Valve Assemblies are either compatible with or protected from the environment (that is, surrounding conditions) to which they are exposed. Environmental conditions including but not limited to ultraviolet radiation, sunlight, heat, ozone, moisture, water, salt water, chemicals and air pollutants can cause degradation and premature failure.
- 2.9 **Electric Power:** For Valves requiring electric power for control, it is imperative that the electricity be delivered at the proper voltage, current and wattage requirements. To obtain the proper control requirements please refer to the respective Parker product catalog for the specific Valve that is intended for use. If further guidance is required, call the appropriate technical service department identified in the respective Parker product catalog.
- 2.10 **Specifications and Standards:** When selecting Valves, government, industry and Parker specifications and recommendations must be reviewed and followed as applicable.
- 2.11 **Accessories:** All accessories used in conjunction with any Parker Valve product must be rated to the same requirements of the Valve including but not limited to pressure, flow, material compatibility, power requirements. All of these items must be examined as stated in the “VALVE INSTALLATION INSTRUCTIONS” paragraph 3.0.

(continued on next page)

### 3.0 **VALVE INSTALLATION INSTRUCTIONS**

- 3.1 **Component Inspection:** Prior to use, a careful examination of the Valve(s) must be performed. The Valve intended for use must be checked for correct style, size, catalog number and external condition. The Valve must be examined for cleanliness, absence of external defects or gouges, cracked or otherwise deformed parts or missing items. The mounting surface or port connections must be protected and free of burrs, scratches, corrosion or other imperfections. Do NOT use any item that displays any signs of nonconformance. In addition, any accessory including but not limited to fittings, bolt kits, hoses, sub bases, manifolds, and electrical connectors must be subjected to the same examination.
- 3.2 **Handling Valves:** Many Valves whether HVD Valves or of another manufacturer can be large, bulky or otherwise difficult to handle. Care must be taken to use proper lifting techniques, tools, braces, lifting belts or other aids so as not to cause injury to the user, any other person or to property.
- 3.3 **Filtration:** Fluid cleanliness is a necessity in any hydraulic system. Fluid filters must be installed and maintained in the system to provide the required level of fluid cleanliness. Filters can be placed in the inlets, pressure lines and return lines. The level of cleanliness required is specified in the HVD product catalog for the specific Valve(s) selected or intended for use. For additional information on Filter selection contact Parker Filter Division at 800-253-1258 or 419-644-4311.
- 3.4 **Servo Valves:** Application of Servo Valves in general requires knowledge and awareness of “closed loop control theory” and the use of electronic controls for successful and safe operation. Individuals who do not have such experience or knowledge must gain training before use of such Products. Parker offers both classroom training as well as manuals to assist in gaining this knowledge. These aids can be obtained by contacting Hydraulic Valve Division at 440-366-5100, calling the general Parker help line 800-CPARKER or going to the Parker web site at [www.parker.com](http://www.parker.com).
- 3.5 **Accessory Ratings:** All accessories used in combination with the selected or intended Valve product must be rated and compatible with the selected Valve. Specifically, the items must be of equal or greater rating including but not limited to pressure, flow, power, size, port style, thread connectors and material.
- 3.6 **Connection Styles:** It is the responsibility of the user of the Parker product to properly select connectors and accessories that match the connections on the sub plate, Valve, flange or threaded connection or manifold. It is also the responsibility of the installer to possess adequate skill and knowledge including but not limited to thread preparation, torque technique, hose assembly and inspection, tube preparation and assembly, and fitting installation. Parker Tube Fitting Division ([www.parker.com/tfd](http://www.parker.com/tfd)) catalog 4300 and Parker Hose Products ([www.parkerhose.com](http://www.parkerhose.com)) catalog 4400 describe some basic technical information relative to proper fitting assembly.
- 3.7 **Electrical Connections:** All electrical connections must be made to the applicable codes and local safety requirements.
- 3.8 **Gauges and Sensors:** The user must install sufficient gauges and sensors in the system so as to be able to determine the condition of the system. This includes but is not limited to pressure gauges, flow meters, temperature sensors and site gauges. These are of utmost importance should removal or disassembly of a Valve, portion of a Valve or portion of the system become necessary. Refer to “VALVE MAINTENANCE AND REPLACEMENT INSTRUCTIONS” for details and especially item 4.8.
- 3.9 **System Checkout:** Once installed, the Valve installation must be tested to insure proper operation and that no external leakage exists. All safety equipment must be in place including but not limited to safety glasses, helmets, ear protection, splash guards, gloves, coveralls and any shields on the equipment. All air entrapment must be eliminated and the system pressurized to the maximum system pressure (at or below the Valve maximum working pressure) and checked for proper function and freedom from leaks. Personnel must stay out of potentially hazardous areas while testing and using.

### 4.0 **VALVE MAINTENANCE AND REPLACEMENT INSTRUCTIONS**

- 4.1 **Maintenance Program:** Even with proper installation, Valves and Valve System life may be significantly reduced without a continuing maintenance program. The severity of the application and risk potential must determine the frequency of the inspection and the replacement of the Products so that Products are replaced before any failure occurs. A maintenance program must be established and followed by the user and, at a minimum, must include instructions 4.2 through 4.10. An FMEA (Failure Mode and Effects Analysis) is recommended in determining maintenance requirements.
- 4.2 **Visual Inspection-Valves:** Any of the following conditions require immediate shut down and replacement of the Valve.
- Evidence that the Valve is in partial dis-assembly.
  - Visible crack or suspicion of a crack in the Valve housing or bent, cracked or otherwise damaged solenoid.
  - Missing or partially extending drive pin on a flow control knob.
  - Missing, loose components, obstructions or other condition impeding the motion or function of the manual knob, lever, foot pedal or other mechanical operator of a hydraulic Valve.
  - Any evidence of burning or heat induced discoloration.
  - Blistered, soft, degraded or loose cover of any kind.
  - Loose wire or electrical connector.
- 4.3 **Visual Inspection-Other:** The following conditions must be tightened, repaired, corrected or replaced as required.
1. Fluid on the ground must be cleaned immediately. Also, the source of the fluid must be determined prior to running the equipment again.
  2. Leaking port or excessive external dirt build-up.
  3. System fluid level is too low or air is entrapped or visible in the reservoir.
  4. Equipment controlled by the Valve or Valve assembly has been losing power, speed, efficiency
- 4.4 **Filter Maintenance:** System filters must be maintained and kept in proper working order. The main service requirement is periodic replacement of the filter element or screen. Contact Parker Filter Division at 800-253-1258 or 419-644-4311 for further filter maintenance details.
- 4.5 **Functional Test:** See “System Checkout” number 3.9 above in “VALVE INSTALLATION INSTRUCTIONS”.
- 4.6 **Replacement Intervals:** Valves and Valve Systems will eventually age and require replacement. Seals especially should be inspected and replaced at specific replacement intervals based on previous experience, government or industry recommendations, or when failures could result in unacceptable downtime, damage or injury risk. At a minimum seals must be replaced whenever service is rendered to a Valve product.
- 4.7 **Adjustments, Control Knobs, and Other Manual Controls:** System Pressure and Flow are typically adjusted by knobs and/or handles. A set-screw or lock-nut secures the adjustment device so as to maintain the desired setting. This set-screw or lock-nut must first be loosened prior to making any adjustments and re-tightened after adjustment on the HVD Valve. All adjustments must be made in conjunction with pressure gauges and/or flow meters (or by watching the speed of the actuator in the case of setting flow only). See paragraph “Gauges and Sensors” above in the section “VALVE INSTALLATION INSTRUCTIONS”. Under no circumstances should any control knob, adjustment stem, handle, foot pedal or other actuating device be forced beyond the mechanical stop(s) on the Valve. For example, the Parker Safety Notice Bulletin **HY14-3310-B1/US** for HVD Colorflow Valves specifically restricts the adjustment torque to “hand adjust” or “less than 10 ft/lbs” if it cannot be adjusted by hand. Failure to adhere to this may force the knob beyond the stop point allowing it to be ejected at high speed resulting in death, personal injury and property damage. For complete safety instructions on HVD Colorflow Valves, copies of Safety Notice **Bulletin HY14-3310-B1/US** can be obtained directly from the Hydraulic Valve Division at 440-366-5100 or from the Parker web site at [www.parker.com](http://www.parker.com) by selecting the “Safety” button. Parker help line 800-CPARKER is on call 24/7 as well should there be any question about the use of a HVD Valve. Additionally, when making adjustments, always adjust the Valve with all parts of your body to the side of the Valve (that is, the knob is not pointing toward you or anyone else).
- 4.8 **High pressure Warning:** Hydraulic power is transmitted by high-pressure fluids through hoses, fittings and valves, pumps and actuators. This condition can be dangerous and potentially lethal and, therefore, extreme caution must be exercised when working with fluids under pressure. From time to time, hoses, Valves, tubes or fittings fail if they are not replaced at proper time intervals. Typically these failures are the result of some form of misapplication, abuse, wear, or failure to perform proper maintenance. When such failure occurs, generally the high pressure fluid inside escapes in a stream which may or may not be visible to the user. Under no circumstances should the user attempt to locate the leak by “feeling” with their hands or any other part of their body. High-pressure fluids can and will penetrate the skin and cause severe tissue damage and possible loss of limb or life. Even seemingly minor hydraulic fluid injection injuries must be treated immediately by a physician with knowledge of the tissue damaging properties of hydraulic fluid.
- If a hose, tube, fitting or Valve failure occurs, immediately shut down the equipment and leave the area until pressure has been completely released from the system. Simply shutting down the pump may or may not eliminate the pressure in the system. It may take several minutes or even hours for the pressure to be relieved so that the leak area can be examined safely. Once the pressure has been reduced to zero, the suspected leaking item can be taken off the equipment and examined. It must always be replaced if a failure has occurred. Never attempt to patch or repair a connector (especially a hose) or Valve that has failed. Consult the nearest Parker distributor or the appropriate Parker division for component replacement information. Never touch or examine a failed hydraulic component unless it is obvious that the item no longer contains fluid under pressure.

# **WARNING!**

## **FAILURE OR IMPROPER SELECTION OR IMPROPER USE OF THE PRODUCTS AND/OR SYSTEMS DESCRIBED HEREIN OR RELATED ITEMS CAN CAUSE DEATH, PERSONAL INJURY AND PROPERTY DAMAGE.**

This document and other information from Parker Hannifin Corporation, its subsidiaries and authorized distributors provide product and/or system options for further investigation by users having technical expertise. It is important that you analyze all aspects of your application, including consequences of any failure, and review the information concerning the product or system in the current product catalog. Due to the variety of operating conditions and applications for these products or systems, the user, through its own analysis and testing, is solely responsible for making the final selection of the products and systems and assuring that all performance, safety and warning requirements of the application are met. The products described herein, including without limitation, product features, specifications, designs, availability and pricing, are subject to change by Parker Hannifin Corporation and its subsidiaries at any time without notice.

## **Offer of Sale**

The items described in this document are hereby offered for sale by Parker Hannifin Corporation, its subsidiaries or its authorized distributors. This offer and its acceptance are governed by the provisions stated in the full "Offer of Sale".



# Extensive Hydraulic Product Offering

## Accumulators



*Piston, bladder and diaphragm type accumulators, gas bottles and KleenVent reservoir isolators.*

[www.parker.com/accumulator](http://www.parker.com/accumulator)

## Compact Hydraulics



*Self-contained with a motor, gear pump, reservoir, internal valving, load hold checks and relief valves.*

[www.parker.com/oilydyne](http://www.parker.com/oilydyne)

## Cylinders



*Standard and custom hydraulic cylinders for industrial and mobile applications.*

[www.parker.com/hydcyl](http://www.parker.com/hydcyl)

## Electronics/Remote Controls



*Parker's unique IQAN approach combines sturdy, well-tested hardware with intelligent, flexible computing power.*

[www.parker.com/iqan](http://www.parker.com/iqan)

## Filtration



*Pressure and return line filters enhances machine life, reduces maintenance and lowers costs.*

[www.parker.com/hydraulicfilter](http://www.parker.com/hydraulicfilter)

## Integrated Hydraulic Circuits



*Solutions for complex circuits that include threaded cartridge valves integrated into a single manifold.*

[www.parker.com/ihd](http://www.parker.com/ihd)

## Motors



*Full line of high and low speed motors provides power up to 15,000 in-lbs of torque.*

[www.parker.com/pumpmotor](http://www.parker.com/pumpmotor)

## Power Take Off



*Parker Chelsea leads the industry for engineering, innovation and performance in auxiliary power systems.*

[www.parker.com/chelsea](http://www.parker.com/chelsea)

## Power Units



*The most complete line of standard, pre-engineered, cataloged hydraulic power units in the industry.*

[www.parker.com/pumpmotor](http://www.parker.com/pumpmotor)

## Pumps



*Broad line of energy-efficient hydraulic pumps that includes piston, vane and gear pumps.*

[www.parker.com/mobpump](http://www.parker.com/mobpump)

## Rotary Actuator



*Industry leader in the design and manufacture of hydraulic rack and pinion, and vane style rotary actuators.*

[www.parker.com/actuator](http://www.parker.com/actuator)

## Valves and Controls



*Hydraulic valves for virtually every hydraulic equipment application, from simple to precise control.*

[www.parker.com/hydraulicvalve](http://www.parker.com/hydraulicvalve)

*Covering the Industrial, Mobile and Truck markets, each catalog is paired with an interactive CD. Call for your comprehensive guides today. 1-800-CParker*

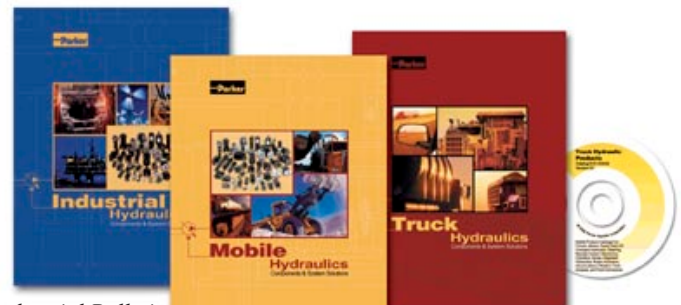

*Industrial Bulletin  
HY01-1000/US*

*Mobile Bulletin  
HY19-1001/US*

*Truck Bulletin  
HY19-1004/US*



# Parker Hydraulics International Sales Offices

## North America

**Hydraulics Group Headquarters**  
6035 Parkland Boulevard  
Cleveland, OH 44124-4141 USA  
Tel: 216-896-3000  
Fax: 216-896-4031

**Parker Hannifin Canada  
Motion & Control Division – Milton**  
160 Chisholm Drive Milton  
Ontario Canada L9T 3G9  
Tel: 905-693-3000  
Fax: 905-876-1958

## Mexico

**Parker Hannifin de México**  
Av eje uno norte num 100  
Parque Industrial Toluca 2000  
Toluca, Mex C.P. 50100  
Tel: 52 722 2754200  
Fax: 52 722 2799308

## Europe

**Europe Hydraulics Group  
Parker Hannifin Corporation**  
Parker House  
55 Maylands Avenue  
Hemel Hempstead, Herts  
HP2 4SJ England  
Tel: 44 1442 458000  
Fax: 44 1442 458085

## Latin America

**Brazil  
Hydraulics Division  
Parker Hannifin Ind. e Com. Ltda**  
Av. FredericoRitter, 1100  
Cachoeirinha RS, 94930-000 Brazil  
Tel: 55 51 3470 9144  
Fax: 55 51 3470 3100

## Mobile Sales

**Mobile Sales Organization  
and Global Sales**  
595 Schelster Road  
Suite 100  
Lincolnshire, IL 60069 USA  
Tel: 847-821-1500  
Fax: 847-821-7600

## Industrial Sales

**Great Lakes Region**  
3700 Embassy Parkway  
Suite 260  
Fairlawn, OH 44333 USA  
Tel: 330-670-2680  
Fax: 330-670-2681

## Southern Region

1225 Old Alpharetta Road  
Suite 290  
Alpharetta, GA 30005 USA  
Tel: 770-619-9767  
Fax: 770-619-9806

## Chicago Region

1163 E. Ogden Avenue  
Suite 705, #358  
Naperville, IL 60563 USA  
Tel: 630-964-0796  
Fax: 866-473-9274

## Pacific Region

8460 Kass Drive  
Buena Park, CA 90621  
Tel: 714-228-2510  
Fax: 714-228-2511

## Eastern Region

100 Corporate Drive  
Lebanon, NJ 08833 USA  
Tel: 908-236-4121  
Fax: 908-236-4146

## Asia Pacific

**Asia Pacific Headquarters  
Parker Hannifin Hong Kong Ltd**  
8/F, Kin Yip Plaza  
9 Cheung Yee Street  
HK-Cheung Sha Wan, Hong Kong  
Tel: 852 2428 8008  
Fax: 852 2425 6896

## Australia Headquarters

**Parker Hannifin Pty Ltd.**  
9 Carrington Road  
Castle Hill, NSW 2154, Australia  
Tel: 612 9634 7777  
Fax: 612 9842 5111

## China Headquarters

**Parker Hannifin Motion & Control  
(Shanghai) Co., Ltd**  
280 Yunqiao Road,  
Jin Qiao Export Processing Zone  
CN-Shanghai 201206, China  
Tel: 86 21 5031 2525  
Fax: 86 21 5834 3714

## Korea Headquarters

**Parker Hannifin Korea Ltd**  
6F Daehwa Plaza  
169 Samsung-dong, Gangnam-gu  
KR-Seoul, 135-090, Korea  
Tel: 82 2 559 0400  
Fax: 82 2 556 8187

## South Africa

**Parker Hannifin Africa Pty Ltd  
Parker Place**  
10 Berne Avenue Airport  
P.O. Box 1153  
ZA-Kempton Park 1620,  
Republic of South Africa  
Tel: 27 11 961 0700  
Fax: 27 11 392 7213



## Parker Hannifin Corporation Hydraulic Valve Division

520 Ternes Avenue  
Elyria, Ohio 44035 USA  
Tel: 440 366 5200  
Fax: 440 366 5253  
[www.parker.com/hydraulicvalve](http://www.parker.com/hydraulicvalve)

Catalog HY14-2533/US,  
2.5M, 2/08, PageLitho

Your Local Authorized Parker Distributor