

Vane Pumps

Series PVS
Variable Displacement

aerospace
climate control
electromechanical
filtration
fluid & gas handling
hydraulics
pneumatics
process control
sealing & shielding



ENGINEERING YOUR SUCCESS.



WARNING – USER RESPONSIBILITY

FAILURE OR IMPROPER SELECTION OR IMPROPER USE OF THE PRODUCTS DESCRIBED HEREIN OR RELATED ITEMS CAN CAUSE DEATH, PERSONAL INJURY AND PROPERTY DAMAGE.

This document and other information from Parker-Hannifin Corporation, its subsidiaries and authorized distributors provide product or system options for further investigation by users having technical expertise.

The user, through its own analysis and testing, is solely responsible for making the final selection of the system and components and assuring that all performance, endurance, maintenance, safety and warning requirements of the application are met. The user must analyze all aspects of the application, follow applicable industry standards, and follow the information concerning the product in the current product catalog and in any other materials provided from Parker or its subsidiaries or authorized distributors.

To the extent that Parker or its subsidiaries or authorized distributors provide component or system options based upon data or specifications provided by the user, the user is responsible for determining that such data and specifications are suitable and sufficient for all applications and reasonably foreseeable uses of the components or systems.

Offer of Sale

Please contact your Parker representation for a detailed "Offer of Sale".

Contents	Page
Characteristics.....	4
Technical data	4
Selection table.....	4
Ordering code	4
Standard Pressure Compensator	5
Compensator type S (PVS: Standard pressure compensator).....	5
Schematic diagram and performance curves.....	5
Task and function	5
Dimensions	5
Double Pressure Compensator	6
Compensator type D, low pressure – high pressure (PVD: Two-stage pressure compensator).....	6
Schematic diagram and performance curves.....	6
Task and function	6
Dimensions	6
Pump Combinations	7
PVS pumps with thru drive.....	7
Mounting kits for pump combinations.....	7

Technical data

Displacement	[cm ³ /rev]	from 8 to 50
Operating pressures		
Outlet	[bar]	140
Inlet min.	[bar]	1.0 0.8 absolute
Drain port	[bar]	max. 0.5
Speed ranges	[min ⁻¹]	1000...1800
Press. fluid temperature	[°C]	-10...+70
Viscosity range	[mm ² /s]	22 - 100 800 (short-term at start up)
Rotation		clockwise

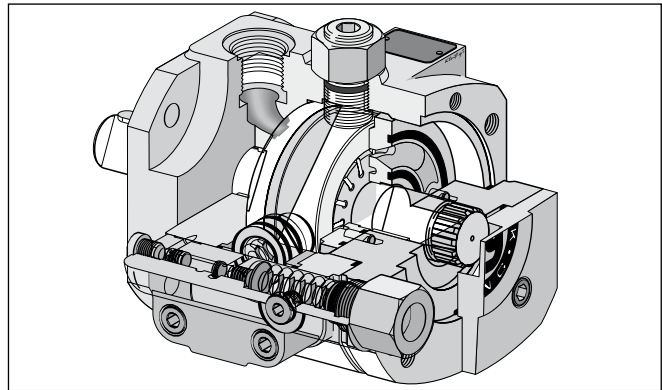

Selection table

Model	Displacement in cm ³ /rev	Output flow at 1500 rpm in l/min	Input power at nominal pressure in kW	Weight in kg single pump	Weight in kg main pump	Weight in kg intermediate pump	Weight in kg second pump
PVS08	8.3	12	3.65	8.9	8.9	8.8	8.8
PVS12	12.8	19	5.0	8.9	8.9	8.8	8.8
PVS16	16	23	8.7	18.1	16.9	18.0	16.8
PVS25	24	35	9.9	18.1	16.9	18.0	16.8
PVS32	31	45	12.7	33.2	30.8	33.0	30.6
PVS40	40	60	15.9	33.2	30.8	33.0	30.6
PVS50	51.5	75	19.7	33.2	30.8	33.0	30.6

Ordering code

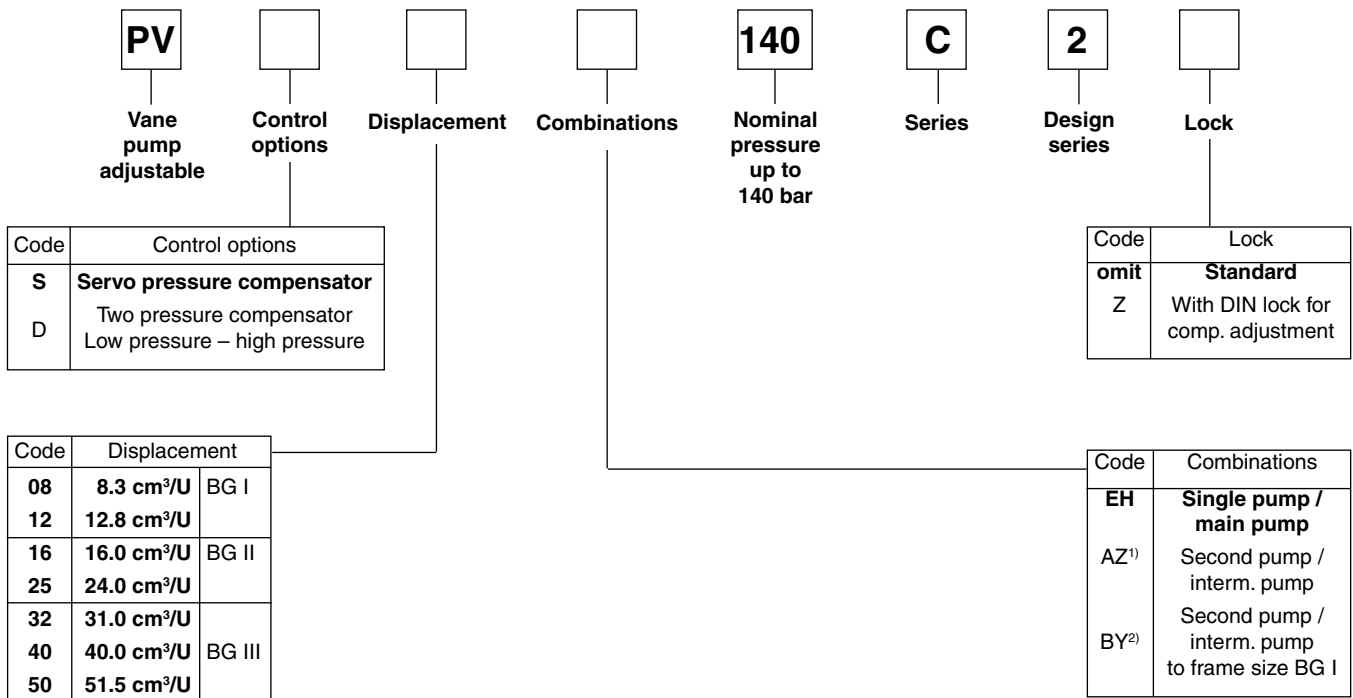

¹⁾ only for BG II and BG III

²⁾ only for BG I

Compensator type S (PVS: Standard pressure compensator)

The pressure is mechanically adjustable via the preload of the pilot control cartridge spring.

Schematic diagram and performance curves

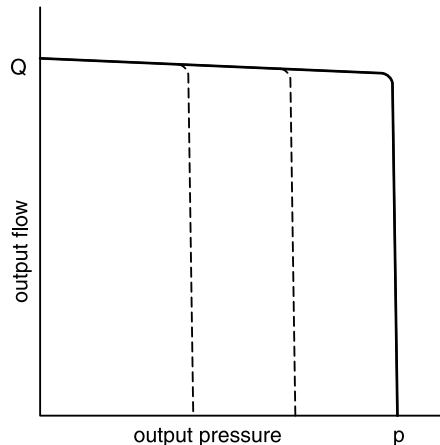
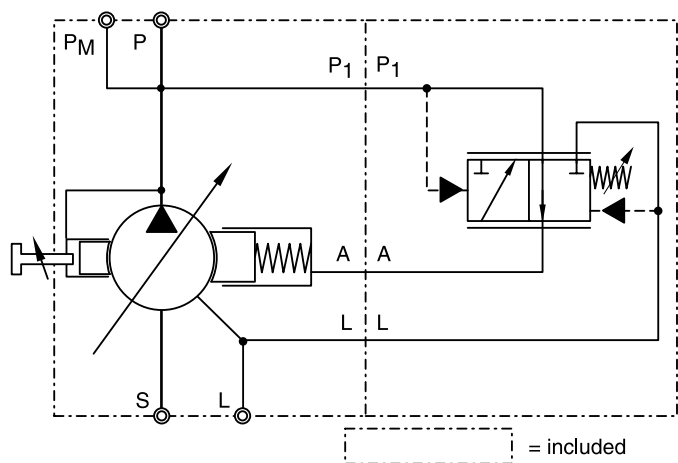

Task and function

When reaching the set pressure on the compensator, the pressure flow of the servo-controlled pump is automatically adjusted to the actual pressure flow requirement of the consumer.

Thus an undesired flow is avoided and only the required medium amount is delivered. As long as the system pressure is lower than the set pressure on the compensator, the stroke ring is kept in the position of

maximum eccentricity, so that the pump continues its full delivery. If the system pressure exceeds the set compensator pressure, the control valve opens, and the pressure on the control piston is relieved. The stroke ring is moved by the auxiliary piston up to the central position to the point where the pressure flow corresponds to the system requirements at the set pressure. The pump is regulated.

Dimensions

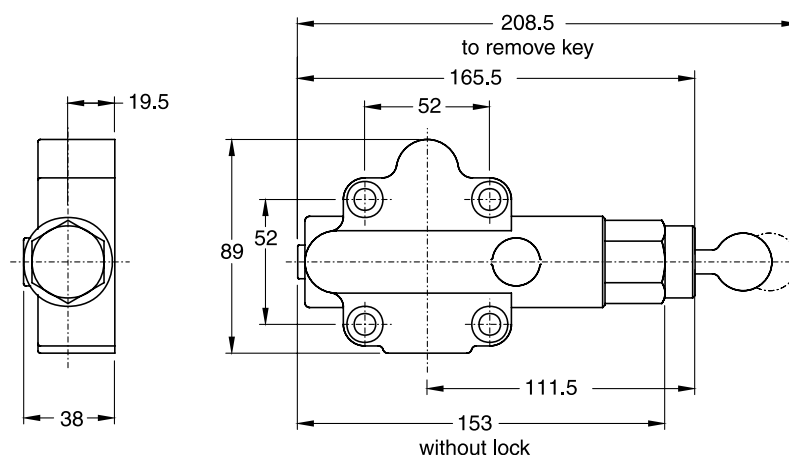

Compensator type D, low pressure – high pressure (PVD: Two-stage pressure compensator)

High pressure and low pressure mechanically adjustable via spring pre-loading, electric switching.

Schematic diagram and performance curves

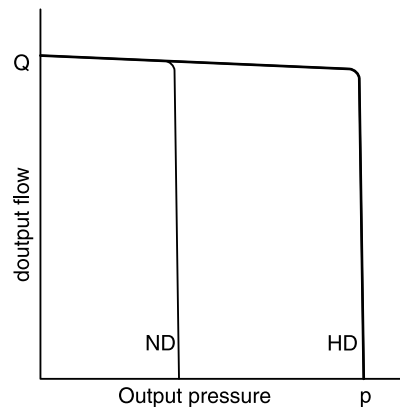
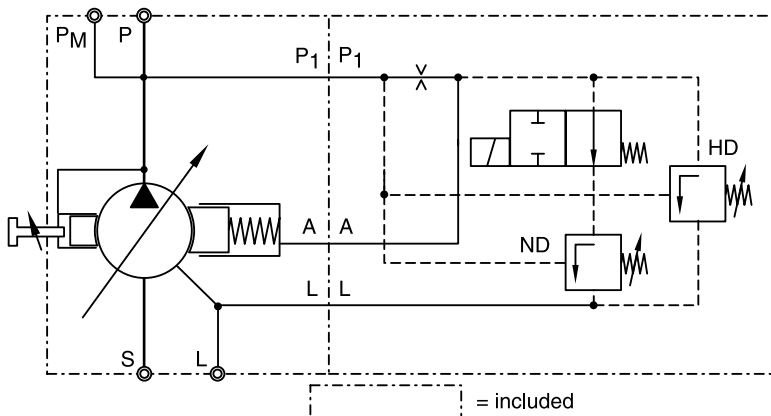

Task and function

The double pressure compensator offers the user the possibility to electrically select between two different pressures. Hydraulic systems, where a higher pressure is only needed in peaks, can be created to be very energy-saving, based on such a design. The double pressure compensator can also be labelled as a double servo pressure compensator, divided into low and high pressure stages. Both compensator pistons are connected together via an integrated directional valve.

Initially both compensator pistons are pressurised with system pressure at the unloaded directional valve. The compensator piston with the lower spring pre-loading is responsible for the system pressure. If the directional valve piston is changed over from LP to HP via electrical signal, the connection to the low pressure compensator piston is interrupted. Then, only the high pressure compensator piston is connected to the pilot oil space. The actual control process for the pump corresponds to one from a servo pressure compensator.

Dimensions

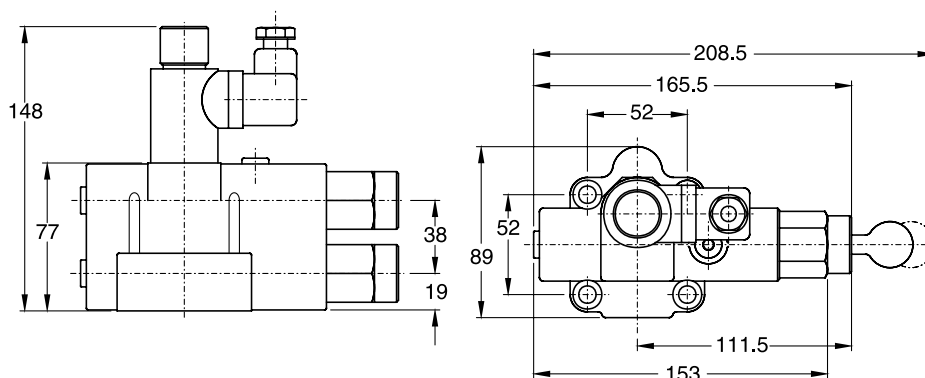

PVS pumps with thru drive

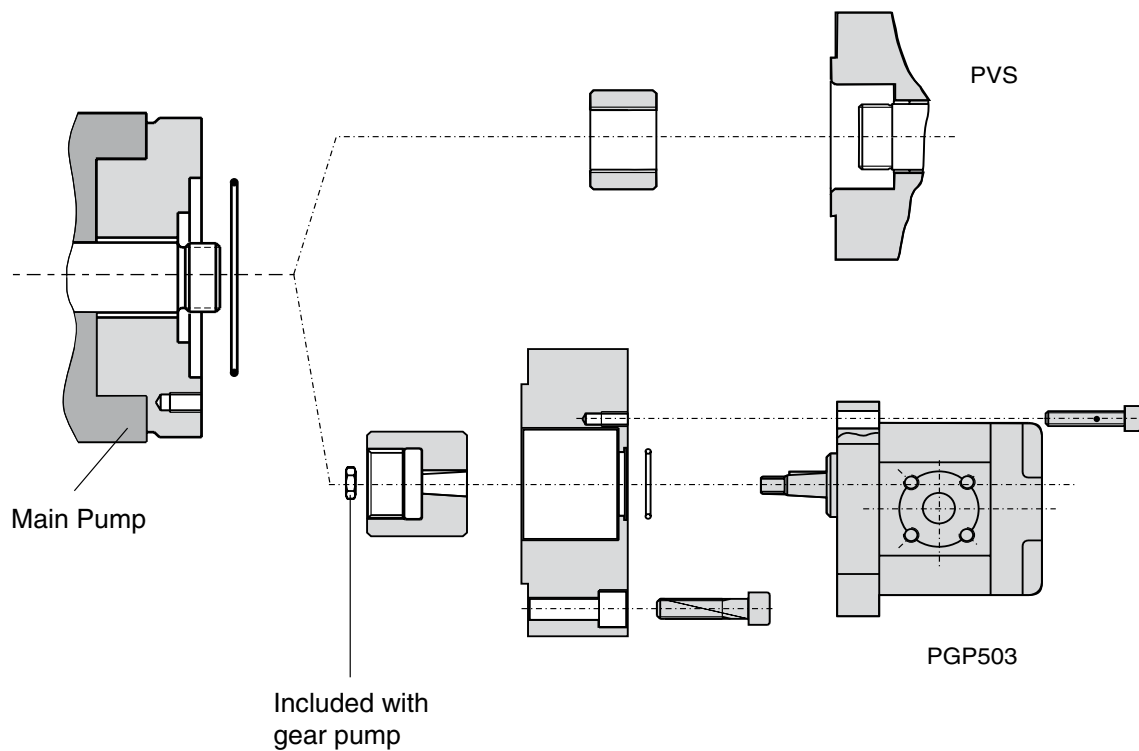

Mounting kits for pump combinations

MK-PVSBG1-PGP503
MK-PVSBG1-PVSBG1

MK-PVSBG2-PGP503
MK-PVSBG2/3-PVSBG1
MK-PVSBG2/3-PVSBG2/3

MK-PVSBG3-PGP503

Parker Worldwide

AE – UAE, Dubai
Tel: +971 4 8127100
parker.me@parker.com

AR – Argentina, Buenos Aires
Tel: +54 3327 44 4129

AT – Austria, Wiener Neustadt
Tel: +43 (0)2622 23501-0
parker.austria@parker.com

AT – Eastern Europe, Wiener Neustadt
Tel: +43 (0)2622 23501 900
parker.easteurope@parker.com

AU – Australia, Castle Hill
Tel: +61 (0)2-9634 7777

AZ – Azerbaijan, Baku
Tel: +994 50 2233 458
parker.azerbaijan@parker.com

BE/LU – Belgium, Nivelles
Tel: +32 (0)67 280 900
parker.belgium@parker.com

BR – Brazil, Cachoeirinha RS
Tel: +55 51 3470 9144

BY – Belarus, Minsk
Tel: +375 17 209 9399
parker.belarus@parker.com

CA – Canada, Milton, Ontario
Tel: +1 905 693 3000

CH – Switzerland, Etoy
Tel: +41 (0) 21 821 02 30
parker.switzerland@parker.com

CL – Chile, Santiago
Tel: +56 2 623 1216

CN – China, Shanghai
Tel: +86 21 2899 5000

CZ – Czech Republic, Klecany
Tel: +420 284 083 111
parker.czechrepublic@parker.com

DE – Germany, Kaarst
Tel: +49 (0)2131 4016 0
parker.germany@parker.com

DK – Denmark, Ballerup
Tel: +45 43 56 04 00
parker.denmark@parker.com

ES – Spain, Madrid
Tel: +34 902 330 001
parker.spain@parker.com

FI – Finland, Vantaa
Tel: +358 (0)20 753 2500
parker.finland@parker.com

FR – France, Contamine s/Arve
Tel: +33 (0)4 50 25 80 25
parker.france@parker.com

GR – Greece, Athens
Tel: +30 210 933 6450
parker.greece@parker.com

HK – Hong Kong
Tel: +852 2428 8008

HU – Hungary, Budapest
Tel: +36 1 220 4155
parker.hungary@parker.com

IE – Ireland, Dublin
Tel: +353 (0)1 466 6370
parker.ireland@parker.com

IN – India, Mumbai
Tel: +91 22 6513 7081-85

IT – Italy, Corsico (MI)
Tel: +39 02 45 19 21
parker.italy@parker.com

JP – Japan, Fujisawa
Tel: +81 (0)4 6635 3050

KR – South Korea, Seoul
Tel: +82 2 559 0400

KZ – Kazakhstan, Almaty
Tel: +7 7272 505 800
parker.easteurope@parker.com

LV – Latvia, Riga
Tel: +371 6 745 2601
parker.latvia@parker.com

MX – Mexico, Apodaca
Tel: +52 81 8156 6000

MY – Malaysia, Shah Alam
Tel: +60 3 7849 0800

NL – The Netherlands, Oldenzaal
Tel: +31 (0)541 585 000
parker.nl@parker.com

NO – Norway, Ski
Tel: +47 64 91 10 00
parker.norway@parker.com

NZ – New Zealand, Mt Wellington
Tel: +64 9 574 1744

PL – Poland, Warsaw
Tel: +48 (0)22 573 24 00
parker.poland@parker.com

PT – Portugal, Leca da Palmeira
Tel: +351 22 999 7360
parker.portugal@parker.com

RO – Romania, Bucharest
Tel: +40 21 252 1382
parker.romania@parker.com

RU – Russia, Moscow
Tel: +7 495 645-2156
parker.russia@parker.com

SE – Sweden, Spånga
Tel: +46 (0)8 59 79 50 00
parker.sweden@parker.com

SG – Singapore
Tel: +65 6887 6300

SK – Slovakia, Banská Bystrica
Tel: +421 484 162 252
parker.slovakia@parker.com

SL – Slovenia, Novo Mesto
Tel: +386 7 337 6650
parker.slovenia@parker.com

TH – Thailand, Bangkok
Tel: +662 717 8140

TR – Turkey, Istanbul
Tel: +90 216 4997081
parker.turkey@parker.com

TW – Taiwan, Taipei
Tel: +886 2 2298 8987

UA – Ukraine, Kiev
Tel: +380 44 494 2731
parker.ukraine@parker.com

UK – United Kingdom, Warwick
Tel: +44 (0)1926 317 878
parker.uk@parker.com

US – USA, Cleveland (industrial)
Tel: +1 216 896 3000

US – USA, Lincolnshire (mobile)
Tel: +1 847 821 1500

VE – Venezuela, Caracas
Tel: +58 212 238 5422

ZA – South Africa, Kempton Park
Tel: +27 (0)11 961 0700
parker.southafrica@parker.com



European Product Information Centre

Free phone: 00 800 27 27 5374
(from AT, BE, CH, CZ, DE, EE, ES, FI, FR, IE,
IL, IS, IT, LU, MT, NL, NO, PT, SE, SK, UK)

US Product Information Centre

Free phone: 1-800-27 27 537
www.parker.com