



BRAND	GROOVER MODEL	ROLLER PART NUMBER	NOTES
VICTAULIC	VE272SFS	RP08272012	Parker approved and tested
VICTAULIC	VE270SFD	RP08272012	Parker approves and tested
VICTAULIC	VE416FS	RP08416012	Not tested
VICTAULIC	RG3212	RP08321212	Not tested
VICTAULIC	VE460	RPQ1460012	Not tested

RIGID	MODEL # 918	WILL NOT WORK DO NOT USE
--------------	--------------------	---------------------------------

VE272SFS Pipe/Tubing Roll Grooving Tool

**WARNING****WARNING**

Failure to follow instructions and warnings could result in death or serious personal injury and property damage.

- Before operating or servicing the VE272SFS tool read all instructions in this manual and all warning labels on the tool.
- Wear safety glasses, hardhat, foot protection, and hearing protection.
- Save this operating and maintenance manual in a place accessible to all operators of the tool.

If you need additional copies of any literature, or if you have questions concerning the safe and proper operation of this tool, contact Victaulic, P.O. Box 31, Easton, PA 18044-0031, Phone: 1-800-PICK VIC, E-Mail: pickvic@victaulic.com



Original Instructions

TABLE OF CONTENTS

Hazard Identification	4	Maintenance	34
Operator Safety Instructions	4	Lubrication	34
Introduction	6	Checking And Filling Hydraulic Systems	36
Receiving the Tool	6	Air Bleeding	37
Container Contents	6	Parts Ordering Information	37
Power Requirements	7	Accessories	37
Power Drive Requirements	7	Troubleshooting	40
Extension Cord Requirements	7	Tool Rating and Roll Selection	42
Tool Nomenclature	8	OGS and “ES” Rolls for Steel And Stainless Steel Pipe	42
Tool Dimensions and Specifications	9	OGS Rolls for Aluminum and PVC Plastic Pipe	43
Tool Setup	10	RX Rolls for Schedule 5S and 10S Stainless Steel Pipe	44
Pre-Operation Checks and Adjustments	14	Rolls for CTS US Standard – ASTM Drawn Copper Tubing	45
Grooving Rolls	14	Rolls for European Standard – EN 1057 Drawn Copper Tubing	46
Pipe Preparation	15	Rolls for Australian Standard – AS 1432 Drawn Copper Tubing	47
Groovable Pipe Lengths		Explanation of Critical Roll	
Short Pipe Lengths	15	Groove Dimensions	48
Long Pipe Lengths	17	Roll Groove Specifications	50
Roll Guard Adjustment	18	Steel, Stainless Steel, Aluminum, And PVC Pipe	50
Pipe Stabilizer Adjustment	20	Steel Pipe And All Materials Grooved With “ES” Rolls	53
Groove Diameter Stop Adjustment	22	CTS US Standard – ASTM B-88 And ASTM B-306 Copper Tubing	54
Grooving Operation	24	European Standard – EN 1057 Copper Tubing	55
Roll Changing	27	Australian Standard – AS 1432 Copper Tubing	56
Lower Roll Removal For 2-inch/50 mm And Larger Sizes	28	EC Declaration of Incorporation	58
Upper Roll Removal	29		
Arbor Removal	29		
Lower Roll/Adapter Assembly Installation For ¾-inch/20 mm And 1 – 1½-inch/ 25 – 40 mm Sizes	30		
Upper Roll Installation	31		
Lower Roll/Adapter Assembly Removal For ¾-inch/20 mm And 1 – 1½-inch/ 25 – 40 mm Sizes	32		
Arbor Installation	32		
Lower Roll Installation For 2-inch/50 mm And Larger Sizes	33		

HAZARD IDENTIFICATION

Definitions for identifying the various hazard levels are provided below.



This safety alert symbol indicates important safety messages. When you see this symbol, be alert to the possibility of personal injury.

Carefully read and fully understand the message that follows.



DANGER

- The use of the word “DANGER” identifies an immediate hazard with a likelihood of death or serious personal injury if instructions, including recommended precautions, are not followed.



WARNING

- The use of the word “WARNING” identifies the presence of hazards or unsafe practices that could result in death or serious personal injury if instructions, including recommended precautions, are not followed.



CAUTION

- The use of the word “CAUTION” identifies possible hazards or unsafe practices that could result in personal injury and product or property damage if instructions, including recommended precautions, are not followed.

NOTICE

- The use of the word “NOTICE” identifies special instructions that are important but not related to hazards.

OPERATOR SAFETY INSTRUCTIONS

The VE272SFS is designed for the sole purpose of roll grooving pipe. These instructions must be read and understood by each operator PRIOR to working with the grooving tools. These instructions describe safe operation of the tool, including set up and maintenance. Each operator must become familiar with the tool's operations, applications, and limitations. Particular care should be given to reading and understanding the dangers, warnings, and cautions described throughout these operating instructions.

Use of these tools requires dexterity and mechanical skills, as well as sound safety habits. Although these tools are designed and manufactured for safe, dependable operation, it is difficult to anticipate all combinations of circumstances that could result in an accident. The following instructions are recommended for safe operation of these tools. The operator is cautioned to always practice “safety first” during each phase of use, including set up and maintenance. It is the responsibility of the lessee or user of these tools to ensure that all operators read this manual and fully understand the operation of these tools.

Store this manual in a clean, dry area where it is always readily available. Additional copies of this manual are available upon request through Victaulic.



DANGER

1. **Avoid using the tool in potentially dangerous environments.** Do not expose the tool to rain, and do not use the tool in damp or wet locations. Do not use the tool on sloped or uneven surfaces. Keep the work area well lit. Allow sufficient space to operate the tool properly.
2. **Ground the drive motor to protect the operator from electric shock.** Ensure that the drive motor is connected to an internally grounded electrical source.

3. **Disconnect the power cord from the electrical source before servicing the tool.** Only authorized personnel should perform maintenance on the tool. Always disconnect the power cord from the electrical source before servicing or adjusting the tool.
4. **Prevent accidental startups.** Place the power switch in the “OFF” position before connecting the tool to an electrical source.

 **WARNING**

1. **Prevent back injury.** DO NOT attempt to lift tool components without the use of mechanical lifting equipment, or with fewer than two people.
2. **Wear proper apparel.** Do not wear loose clothing, jewelry, or anything that can become entangled in moving parts.
3. **Wear protective items when working with tools.** Always wear safety glasses, hard hat, foot protection, and hearing protection.
4. **Keep hands and tools away from grooving rolls and stabilizer wheel during the grooving operation.** Grooving rolls can crush or cut fingers and hands.
5. **Do not reach inside pipe ends during tool operation.** Pipe edges can be sharp and can snag gloves, hands, and shirt sleeves.
6. **Operate the tool from the control station side only.** The tool must be operated with the safety foot switch that is located for easy operator access. Never reach across moving parts. If the tool does not contain a safety foot switch, do not use the tool, and contact Victaulic.
7. **Do not over-reach.** Maintain proper footing and balance at all times. Ensure that the safety foot switch is easily accessible for the operator.

 **CAUTION**

1. **This tool is designed ONLY for roll grooving pipe/tubing sizes, materials, and wall thicknesses listed in the “Tool Rating and Roll Selection” section.**
2. **Inspect the equipment.** Before using the tool, check all moveable parts for any obstructions. Ensure that tool components are installed and adjusted in accordance with the “Tool Setup” section.
3. **Stay alert.** Do not operate the tool if you are drowsy from medication or fatigue.
4. **Keep visitors, trainees, and observers away from the immediate work area.** All visitors should be kept a safe distance from the equipment at all times.
5. **Keep work areas clean.** Keep the work area around the tool clear of any obstructions that could limit movement of the operator. Clean up any spills.
6. **Secure the work, machine, and accessories.** Ensure that the tool is stable. Refer to the “Tool Setup” section.
7. **Support the work.** Support long pipe/tubing lengths with a pipe stand, in accordance with the “Long Pipe Lengths” section.
8. **Do not force the tool.** Do not force the tool or accessories to perform any functions beyond the capabilities described in these instructions. Do not overload the tool.
9. **Maintain tool with care.** Keep the tool clean at all times to ensure proper and safe performance. Follow the instructions for lubricating tool components.
10. **Use only Victaulic replacement parts and accessories.** Use of any other parts may result in a voided warranty, improper operation, and hazardous situations. Refer to the “Parts Ordering Information” and “Accessories” sections.
11. **Do not remove any labels from the tool.** Replace any damaged or worn labels.

INTRODUCTION

NOTICE

- Drawings and/or pictures in this manual may be exaggerated for clarity.
- The tool, along with this operating and maintenance instructions manual, contains trademarks, copyrights, and/or patented features that are the exclusive property of Victaulic.

The Victaulic VE272SFS tool is a hydraulic feed tool for roll grooving pipe to receive Victaulic grooved pipe products. The standard VE272SFS tool is supplied with grooving rolls for 2–12 inch/50–300 mm steel pipe. Rolls are marked with the size and part number, and are color coded to identify the pipe/tubing material. For roll grooving to other specifications and materials, refer to the “Tool Rating and Roll Selection” section. Grooving rolls for other specifications, sizes, and materials must be purchased separately.



CAUTION

- This tool must be used **ONLY** for roll grooving pipe/tubing designated in the “Tool Rating and Roll Selection” section of this manual.

Failure to follow this instruction could overload the tool, resulting in reduced tool life and/or tool damage.

RECEIVING THE TOOL

The VE272SFS tool is palletized individually and enclosed in a cardboard sleeve, which is designed for repeated shipping. Optional roll sets and pipe stabilizer/mounting hardware are shipped in a separate container. Save the original container for return shipment of rental tools and accessories.

Upon receipt of the tool, make sure that all necessary parts are included. If any parts are missing, contact Victaulic.

CONTAINER CONTENTS



Qty.	Description
1	Tool Head with Mounting Table
1	Upper Leg
2	Adjustable Legs
1	Hand Pump/Pump Support
2	Upper Rolls for 2 – 6-inch/50 – 150 mm Steel Pipe and 8 – 12-inch/200 – 300 mm Steel Pipe
3	“Keyless” Lower Rolls for 2 – 3-inch/ 50 – 80 mm, 4 – 6-inch/100 – 150 mm, and 8 – 12-inch/200 – 300 mm Steel Pipe ‡
1	Guard Setting Pad
1	Lower Roll Removal Wedge
1	Can of Dry Graphite Spray
1	Pipe Tape
2	TM-VE272SFS Operating and Maintenance Instructions Manual
1	RP-VE272SFS Repair Parts List

NOTE: Optional items, such as the stabilizer assembly, may be shipped separately.

‡ The 8–12-inch/200–300 mm roll set is mounted on the tool head assembly at the factory

POWER REQUIREMENTS

DANGER

- To reduce the risk of electric shock, check the electrical source for proper grounding.**
- Before performing any maintenance on the tool, disconnect the power cord from the electrical source.**

Failure to follow these instructions could result in death or serious personal injury.

POWER DRIVE REQUIREMENTS

The VE272SFS tool is designed for operation with a power drive. The tool mounts directly onto a Victaulic VPD752 Power Drive or a Ridgid® 300 Power Drive with a 38-rpm maximum chuck speed. Always refer to the operating manual for the power drive for additional information.

Power must be supplied to the power drive through a safety foot switch to ensure safe operation. Ensure that the power drive is properly grounded in accordance with Article 250 of the National Electrical Code.

If an extension cord is required, refer to the “Extension Cord Requirements” section that follows for cord sizes.

EXTENSION CORD REQUIREMENTS

When pre-wired outlets are not available and an extension cord must be used, it is important to use the proper cord size (i.e. Conductor Size American Wire Gauge). Cord size selection is based upon tool rating (amps) and cord length (feet). Use of a cord size (gauge) thinner than required will cause significant voltage drop at the power drive while the tool is operating. Voltage drops may cause damage to the power drive and can result in improper tool operation. **NOTE:** It is acceptable to use a cord size (gauge) that is heavier than required.

The required cord sizes (gauges) for cord lengths up to and including 100 feet/31 m are listed in the table below. Use of extension cords longer than 100 feet/31 m must be avoided.

Power Drive Rating volts/amps	Cord Lengths feet/meters		
	25 8	50 15	100 31
115 15	12 gauge	12 gauge	10 gauge

® Ridgid is a registered trademark of the Ridgid Tool Company

TOOL NOMENCLATURE

NOTICE

- Drawings and/or pictures in this manual may be exaggerated for clarity.
- The tool, along with this operating and maintenance instructions manual, contains trademarks, copyrights, and/or patented features that are the exclusive property of Victaulic.

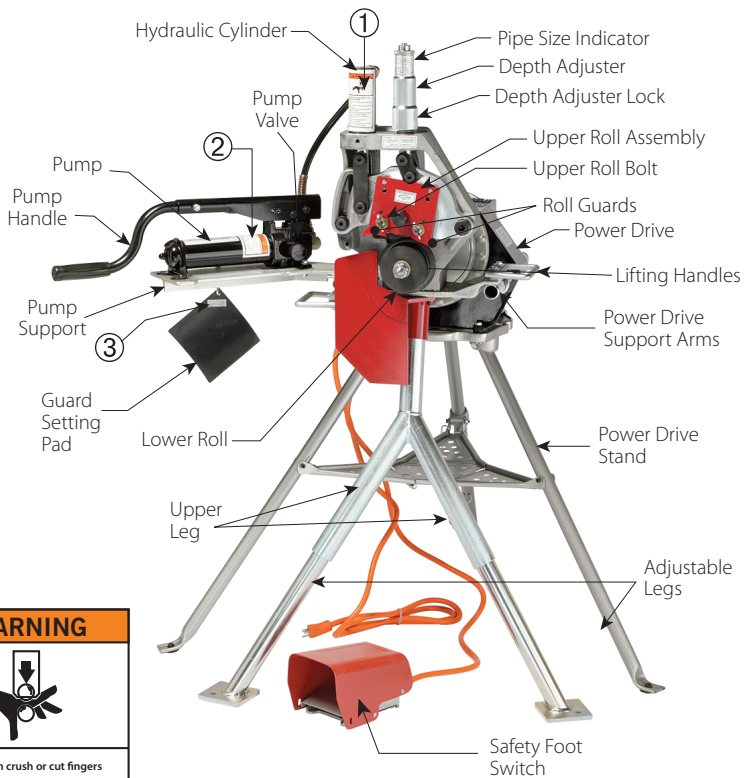

①

⚠ WARNING

Grooving rolls can crush or cut fingers and hands.

- Always disconnect the tool from the power source before making any tool adjustments.
- Make sure the guard is adjusted properly before grooving pipe.
- Loading/unloading pipe will place your hands close to the grooving rolls. Keep hands away from the grooving rolls and the roller on the pipe stabilizer during operation.
- Never reach inside the pipe ends or across the tool or pipe during operation.
- Never groove pipe that is shorter than the recommended lengths listed in the operating and maintenance manual.
- Never wear loose clothing, loose gloves, or anything that can become entangled in moving parts.

2244 Rev. D R027272AB

②

⚠ WARNING

Failure to follow instructions and warnings could result in serious personal injury, property damage, and/or product damage.

- Before operating or servicing any pipe preparation tools, read all instructions in the Operating and Maintenance Instructions Manual and all labels on the tool.
- Wear safety glasses, hardhat, foot protection, and hearing protection when working around tools.

If you need additional copies of any literature, or if you have questions concerning the safe and proper operation of any pipe preparation tools, contact Victaulic, P.O. Box 31, Easton, PA 18044-0031, Phone 1-800-PICK VIG, E-Mail: pickvic@victaulic.com

0367 Rev. D R031272AB

③

ALWAYS KEEP THIS PAD WITH THE TOOL. USE IT TO SET THE GUARDS IN ACCORDANCE WITH THE TOOL OPERATION AND MAINTENANCE MANUAL.

4868 Rev. D R068272LAB

TOOL DIMENSIONS AND SPECIFICATIONS

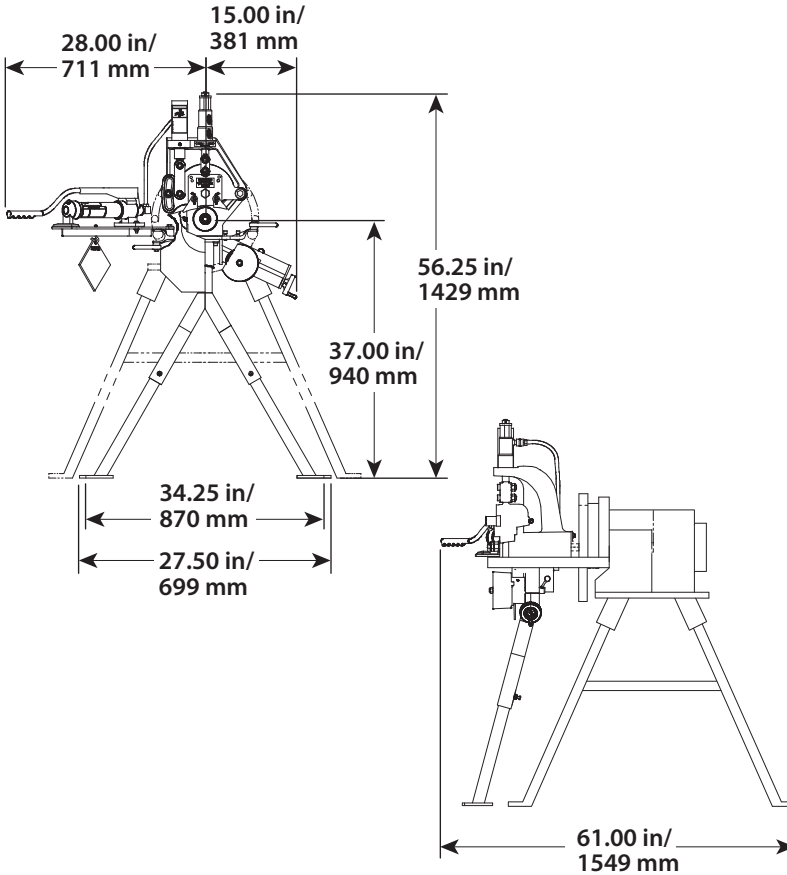

Tool weight is 184 pounds/84 kilograms.

Tool sound pressure is 99.7 dB(A), while tool sound power is 91.7 dB(A). All measurements taken with a VPD 752 power drive.

NOTE: Noise measurements are dependent on the power drive, and will vary based on configuration. Always check the power drive manufacturer's documentation for details.

TOOL SETUP

WARNING

- **DO NOT connect the power drive to the electrical source until instructed otherwise.**

Accidental startup of the tool could result in serious personal injury.

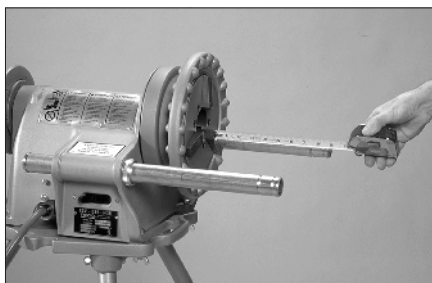

The standard VE272SFS tool is intended for field or shop setup. Before grooving, the tool head assembly and legs must be mounted onto a Victaulic VPD752 Power Drive or a Ridgid 300 Power Drive with a 38-rpm maximum chuck speed.

1. Remove all components from the packaging, and make sure all necessary items are included. Refer to the “Receiving the Tool” section.
2. Select a location for the power drive, tool, and pipe stand by taking into consideration the following factors (refer to the drawing below for overall dimensions):
 - a. The required power supply (refer to the power drive manufacturer’s instructions)
 - b. Adequate space to handle pipe lengths
 - c. A firm and level surface for the power drive, tool, and pipe stand
 - d. Adequate clearance around the tool for adjustment and maintenance

3. Remove threading dies, cutoff attachments, etc. from the power drive. Extend the two tubular support arms approximately 7½ inches/190 mm beyond the chuck of the power drive. Secure the support arms in this position. Refer to the power drive manufacturer’s instructions.
4. Open the chuck of the power drive fully. Refer to the power drive manufacturer’s instructions.

WARNING

- **During tool set-up, at least two people are needed to safely handle the weight of the tool head assembly (184 pounds/ 84 kilograms). If a hoist is available, use it to lift the tool head assembly into position.**

Failure to follow this instruction may result in serious injury.

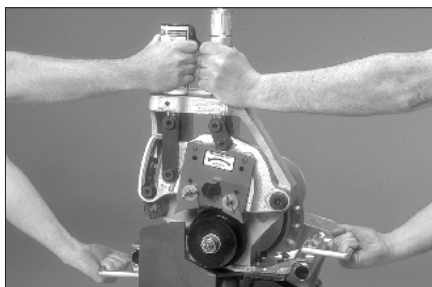

5. Slide the tool head assembly completely onto the arms of the power drive.

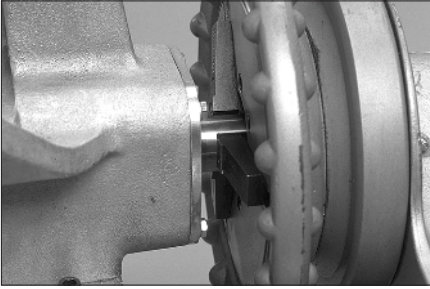

6. Allow approximately ½-inch/13-mm clearance from the hex bolts on the back of the tool to the power drive chuck.
7. Align the flat portions of the drive shaft with the chuck jaws by turning the lower roll.

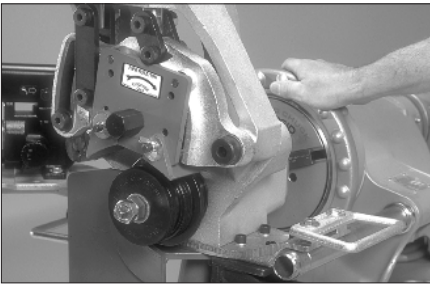

8. Tighten the chuck. Make sure the jaws engage with the flats of the drive shaft.
9. Insert the two adjustable legs completely into the sockets of the upper leg. Hand-tighten the hex bolts.

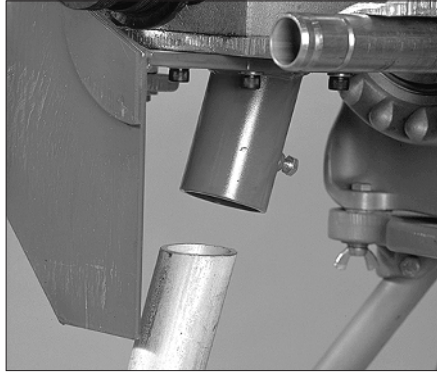

10. Insert the top of the leg assembly completely into the socket under the tool head assembly. Rotate the assembly until it seats completely in the socket. The hex head bolts on the legs should be facing toward the back of the machine (toward the power drive).

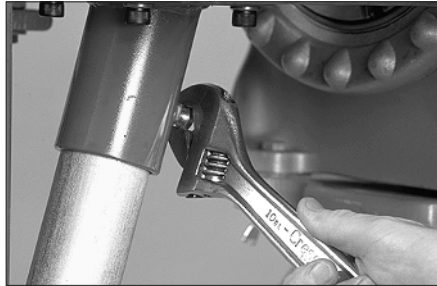

11. Tighten the hex head bolt with a wrench.



12. Loosen the hex bolts to release the two lower legs, allowing them to slide down to the floor. Turn the leg pads at the bottom until they are resting flat of the floor.

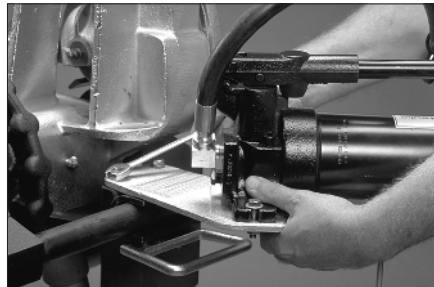

15. Attach the hand pump/pump support to the left side of the tool with the two hex bolts (supplied). Tighten the two hex bolts with a wrench.

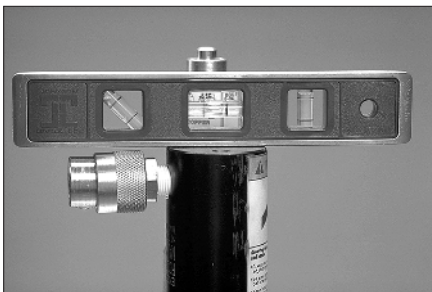

13. Level the tool from front to back.
NOTE: The top of the hydraulic cylinder is a good location to measure “level,” as shown above.



16. Connect the hydraulic line from the hand pump to the power cylinder with the connectors provided.
17. Hang the guard setting pad on the hook provided under the base of the hand pump.

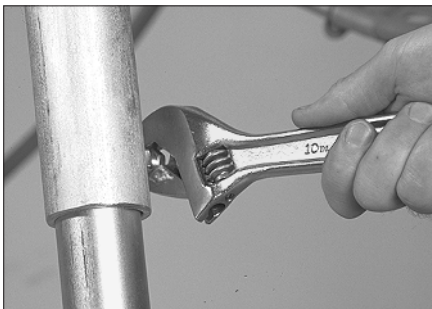

14. Using a wrench, tighten the two hex head bolts on the two legs to maintain the level position.



DANGER



- To reduce the risk of electric shock, check the electrical source for proper grounding.
- Before performing any maintenance on the tool, disconnect the power cord from the electrical source.

Failure to follow these instructions could result in death or serious personal injury.

18. Ensure that the switch on the power drive is in the “OFF” position. Plug the power drive into an internally grounded electrical outlet. The outlet must meet the requirements for the power drive (refer to the power drive manufacturer’s instructions). If an extension cord is used, refer to the “Extension Cord Requirements” section.



WARNING

- DO NOT operate the power drive without a safety foot switch. If the tool does not contain a safety foot switch, contact Victaulic.**

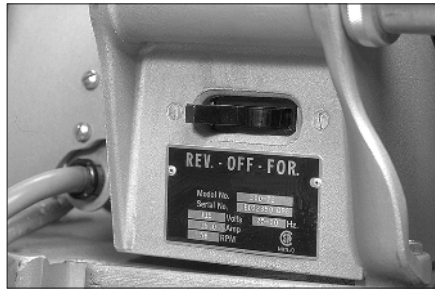
Operating the tool without a safety foot switch could result in serious personal injury.

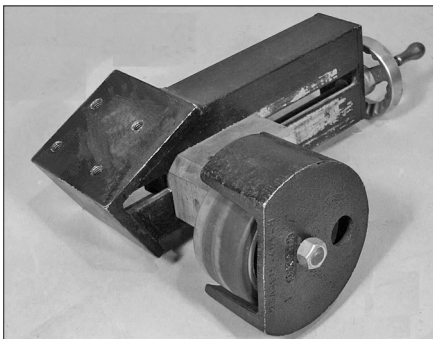

19. Turn the power drive switch to the position that will produce **clockwise** rotation of the chuck when viewed from the front of the tool. On the Victaulic VPD752 or Ridgid 300 Power Drive, placing the switch in the reverse position will produce clockwise rotation of the chuck, lower roll, and pipe.
20. Depress the safety foot switch, check the rotation of the chuck and lower roll, and ensure that the tool is stable. If rotation is counterclockwise, place the switch on the power drive to the opposite position. If the tool wobbles, ensure that the tool is mounted squarely in the chuck and that the tool is level on the floor. If the wobble persists, the power drive support arms are bent or the power drive is damaged. Have the power drive repaired if the wobble persists.
21. Turn the switch on the power drive to the “OFF” position, or disconnect the power cord from the electrical source.



22a. If the optional stabilizer assembly was ordered separately, attach it to the right side of the tool with the four hex bolts and four lock washers provided.

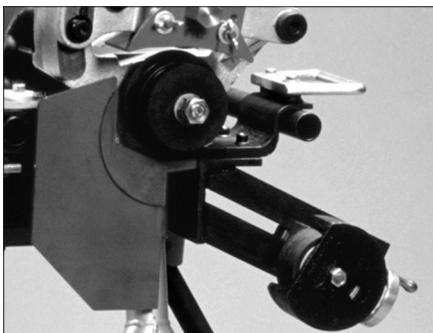

22b. Use the hex bolts provided for installing the screws.

PRE-OPERATION CHECKS AND ADJUSTMENTS

Every Victaulic roll grooving tool is checked, adjusted, and tested at the factory prior to shipment. However, before attempting to operate the tool, the following checks and adjustments should be made to ensure proper tool operation.

WARNING

- **DO NOT** operate the power drive without a safety foot switch. If the tool does not contain a safety foot switch, contact Victaulic.

Operating the tool without a safety foot switch could result in serious personal injury.

GROOVING ROLLS

Ensure that the proper roll set is installed on the tool for the pipe size and material that will be grooved. Roll sets are marked with the pipe size and part number, and they are color coded for the pipe material. Refer to the “Tool Rating and Roll Selection” section. If the proper rolls are not installed on the tool, refer to the “Roll Changing” section.

CAUTION

- Ensure that roll-retaining bolts and nuts are tight. Loose retaining bolts and nuts could cause damage to the tool and rolls.

PIPE PREPARATION

For proper tool operation and production of grooves that are within Victaulic specifications, the following guidelines must be followed.

1. Victaulic recommends square-cut pipe for use with grooved-end pipe products. Square-cut pipe **MUST** be used with FlushSeal® and EndSeal® gaskets. Beveled-end pipe may be used, provided that the wall thickness is standard wall (ANSI B36.10) or less and that the bevel meets ANSI B16.25 (37½°) or ASTM A-53 (30°). **NOTE:** Roll grooving beveled-end pipe may result in unacceptable pipe flare.
2. Raised internal and external weld beads and seams must be ground flush with the pipesurface 2 inches/50 mm back from the pipe ends.
3. All coarse scale, dirt, and other foreign material must be removed from the interior and exterior surfaces of the pipe ends.

CAUTION

- **For maximum grooving roll life, remove foreign material and loose rust from the interior and exterior surfaces of the pipe ends. Rust is an abrasive material that will wear the surface of grooving rolls.**

Foreign material may interfere with or damage grooving rolls, resulting in distorted grooves and grooves that are out of Victaulic specifications.

GROOVABLE PIPE LENGTHS

The VE272SFS is capable of grooving short pipe lengths without the use of a pipe stand. Refer to the “Short Pipe Lengths” section below.

Pipe lengths longer than those listed in Table 1 on the following page (and up to 20 feet/6 meters) must be supported with a pipe stand.

Pipe lengths from 20 feet/6 meters up to double-random lengths (approximately 40 feet/12 meters) must be supported with two pipe stands.

SHORT PIPE LENGTHS

 WARNING	
	<ul style="list-style-type: none"> • Grooving rolls can crush or cut fingers and hands. <p>Never groove pipe that is shorter than the recommended lengths listed in this manual.</p>

Table 1 shows the minimum and maximum pipe lengths that can be grooved without the use of a pipe stand. Refer to the “Grooving Operation” section for instructions on how to groove short pipe lengths. For pipe longer than what is shown in Table 1, refer to the “Long Pipe Lengths” section.

NOTICE

- **Grooved pipe/tubing nipples, shorter than those listed in Table 1, are available from Victaulic.**

TABLE 1 – PIPE LENGTHS SUITABLE FOR GROOVING

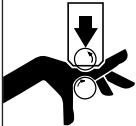
Steel, Stainless Steel, Aluminum, and PVC Pipe		CTS US Standard ASTM B-88 Copper Tubing Size	Length – inches/mm	
Nominal Size inches/ mm	Actual Outside Dia. inches/ mm		Nominal inches/ Actual mm	Min. Max.
3/4	1.050	–	8	36
20	26.9	–	205	915
1	1.315	–	8	36
25	33.7	–	205	915
1¼	1.660	–	8	36
32	42.4	–	205	915
1½	1.900	–	8	36
40	48.3	–	205	915
2	2.375	2	8	36
50	60.3	2	205	915
2½	2.875	2½	8	36
65	73.0	2½	205	915
3	3.500	3	8	36
80	88.9	3	205	915
3½	4.000	–	8	36
90	101.6	–	205	915
4	4.500	4	8	36
100	114.3	4	205	915
4½	5.000	–	8	32
120	127.0	–	205	815
5	5.563	5	8	32
125	141.3	5	205	815
152.4 mm	6.000	–	10	30
	152.4	–	255	765
6	6.625	6	10	28
150	168.3	6	255	715
203.2 mm	8.000	–	10	24
	203.2	–	255	610
8	8.625	8	10	24
200	219.1	8	255	610
10	10.750	–	10	20
250	273.0	–	255	510
12	12.750	–	12	18
300	323.9	–	305	460

Nominal Size Millimeters		Length - millimeters	
European Standard Copper Tubing Size	Australian Standard Copper Tubing Size	Minimum	Maximum
54	DN50	205	915
64	DN65	205	915
66.7		205	915
76.1	DN80	205	915
88.9		205	915
108	DN100	205	915
133	DN125	205	815
159	DN150	255	715

If pipe is required that is shorter than the minimum length listed in Table 1, shorten the next-to-last piece so that the last piece is as long (or longer) than the minimum length specified. Refer to the example below.

EXAMPLE: A 20-foot, 4-inch/6.2-m length of 10-inch/250 mm diameter steel pipe is required to finish a section, and only 20-foot/6.1-m lengths are available. Instead of roll grooving a 20-foot/6.1-m length of steel pipe and a 4-inch/0.1-m length of steel pipe, follow these steps:

1. Refer to Table 1 on this page and note that for 10-inch/250 mm diameter steel pipe, the minimum length that should be roll grooved is 10 inches/255 mm.
2. Roll groove a 19-foot, 6-inch/5.9-m length of pipe and a 10-inch/255-mm length of pipe. Refer to the “Long Pipe/Tubing Lengths” section.

LONG PIPE LENGTHS

When roll grooving pipe that exceeds the maximum length shown in Table 1, a roller-type pipe stand must be used. The roller-type pipe stand must be capable of handling the weight of the pipe, while allowing the pipe to rotate freely.

1. Ensure that the tool is level. Refer to the “Tool Setup” section for leveling requirements.
2. When pipe flare is excessive, right-to-left tracking must be kept to a minimum. It may be necessary to use less than $\frac{1}{2}^\circ$ for the tracking angle.
3. Installation of couplings on pipe that exceeds the maximum allowable flare may prevent pad-to-pad closure of the housings and/or may cause damage to the coupling gasket. Refer to the applicable “Roll Groove Specifications” table for details.
4. If the tool is properly set up in a level position, but the back end of the pipe is higher than the end being grooved, the pipe may not track. As a result, excessive flare may occur on the pipe end. Refer to the “Tool Setup” section and figures 1 and 2 on this page for tool setup and pipe positioning requirements.

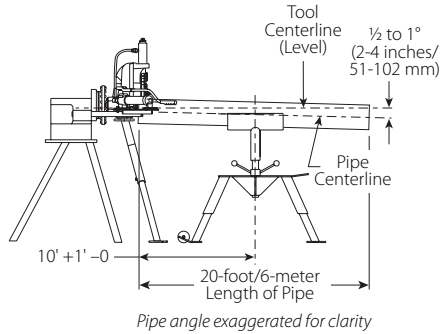

FIGURE 1 - SUPPORT OF PIPE

6. Position the pipe stand approximately $\frac{1}{2}^\circ$ to the left for the tracking angle. Refer to Figure 2 below.

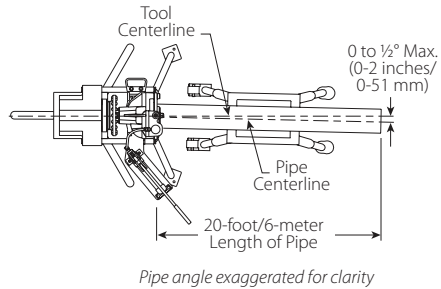

FIGURE 2 - TRACKING ANGLE

NOTICE

- Figure 1 shows a typical pipe stand.
 - Victaulic offers several pipe stands, such as the VAPS112 and VAPS224. Refer to the “Accessories” section for further details.
 - Refer to the manual provided with the pipe stand for additional information regarding setup and maintenance.
5. Place the pipe stand at a distance slightly beyond half the pipe length from the tool. Refer to Figure 1 on this page.

ROLL GUARD ADJUSTMENT

WARNING

- Before making any tool adjustments, always disconnect the power cord from the electrical source.

Accidental startup of the tool could result in serious personal injury.

VE272SFS guards must be adjusted every time rolls are changed or when the pipe size or wall thickness is different from pipe that was grooved previously.

1. Make sure the proper roll set is installed on the tool for the pipe size and material that will be grooved. Roll sets are marked with the pipe size/part number, and they are color-coded for the pipe material. Refer to the “Tool Rating and Roll Selection” section. If the proper rolls are not installed on the tool, refer to the “Roll Changing” section.

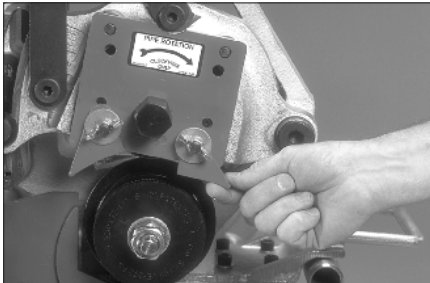

2. Loosen the wing nuts, and move the roll guards to the full-up position. Tighten the wing nuts.



3. Set the groove diameter stop to the pipe size and schedule/thickness that will be grooved. To set the groove diameter stop, back off the depth adjuster lock, align the depth adjuster with the proper diameter and thickness, and lock the setting in position with the depth adjuster lock.



4. If the tool is equipped with a stabilizer, retract the stabilizer, if necessary, to insert the pipe. To retract the stabilizer, loosen the stabilizer locking handle, and retract the stabilizer roller with the hand wheel to provide clearance for the pipe when it is inserted onto the lower roll.

! WARNING

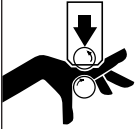

Grooving rolls can crush or cut fingers and hands.

- Before making any tool adjustments, always disconnect the power cord from the electrical source.

- Loading and unloading pipe will place your hands close to the rollers. Keep hands away from the grooving rolls during operation.
- Never reach inside the pipe end or across the tool or pipe during operation.
- Always groove pipe in a direction that rotates away from the operator.
- Never groove pipe that is shorter than the recommended lengths listed in this manual.
- Never wear loose clothing, loose gloves, or anything that can become entangled in moving parts.



6. Close the hand pump valve by turning the knob **clockwise**.

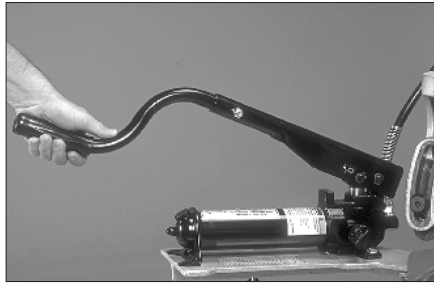

7. Using the hand pump, bring the upper roll down into firm contact with the pipe.

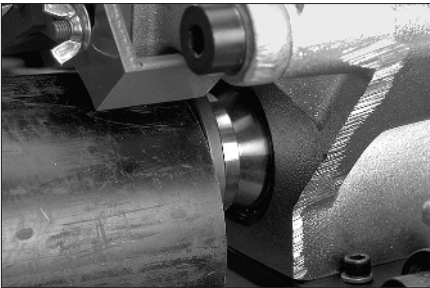

5. Insert a length of pipe of the correct size and schedule/ thickness over the lower roll with the pipe end against the lower roll backstop flange. Refer to the "Pipe/Tubing Preparation" section.

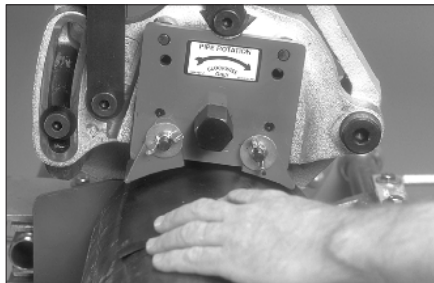

8. Remove the guard-setting pad from its storage hook beneath the pump support. Hold the guard-setting pad firmly against the pipe, and push it under the roll guards until it is flush against the red plate.

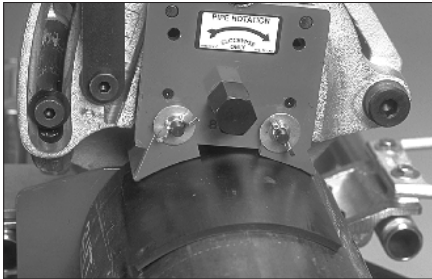
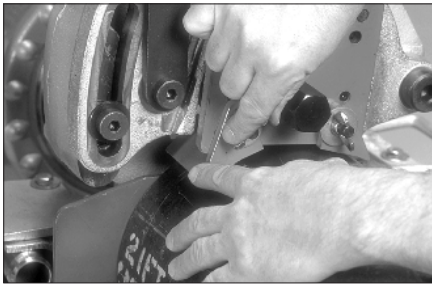

PIPE STABILIZER ADJUSTMENT

(Applies only to tools equipped with the optional pipe stabilizer)

The optional pipe stabilizer for the VE272SFS is designed to prevent pipe sway for 8 – 12-inch/ 200 – 300 mm NPS sizes in short and long lengths. When the stabilizer is adjusted for a selected pipe size and wall thickness, it does not require further adjustment unless pipe of a different size and wall thickness will be grooved. Pipe of the same size and thickness may be moved in and out of the tool without retracting the stabilizer.

WARNING

- **Before making any tool adjustments, always disconnect the power cord from the electrical source.**

Accidental startup of the tool could result in serious personal injury.

9. Loosen the wing nuts, and adjust each guard to conform to and lightly pinch the guard-setting pad against the pipe. Tighten the wing nuts to secure the guards into position.
10. Remove the guard-setting pad. Store the pad back on the hook provided under the pump support.

1. Make sure the proper roll set is installed on the tool for the pipe size and material to be grooved. Rolls are marked with the pipe size, part number, and they are color-coded according to the pipe material. Refer to the “Tool Rating and Roll Selection” section.



2. Loosen the stabilizer locking handle. Using the hand wheel, retract the stabilizer roller to clear the pipe when it is inserted onto the lower roll.

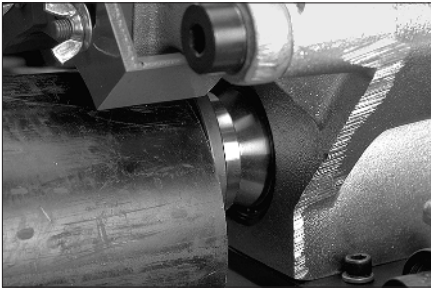

3. Insert a length of pipe that is the correct size and schedule over the lower roll. Make sure the pipe end contacts the lower-roll backstop flange.



4. Close the hand pump valve by turning the knob **clockwise**.

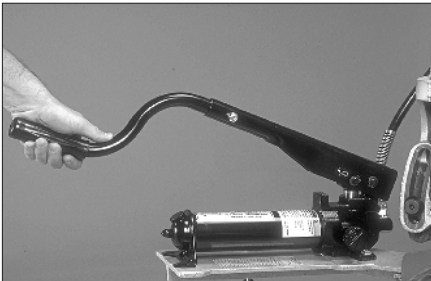

5. Using the hand pump, bring the upper roll down into firm contact with the pipe.
6. Make sure the guards are adjusted properly. Refer to the "Roll Guard Adjustment" section.

⚠ CAUTION

- **DO NOT** adjust the stabilizer to push the pipe to the left and off center from the rolls. Increased pipe-end flare and shortened roll life will result if the pipe is pushed to the left and off center.
- **Assembly of couplings on pipe that exceeds the maximum allowable flare dimension may prevent proper pad-to-pad assembly of coupling housings and may cause gasket distortion/damage.**

Failure to prepare pipe in accordance with all instructions may cause joint failure, resulting in personal injury and/or property damage.



7. Using the hand wheel, advance the stabilizer roller inward until the roller lightly contacts the pipe. Tighten the stabilizer locking handle. Refer to figures 3 and 4 on the next page for proper positioning.
8. Complete all adjustments and groove the pipe. Refer to the "Grooving Operation" section. Observe the stabilizer roller while grooving. It should remain in contact with the pipe, and the pipe should rotate smoothly without swaying from side to side. If the pipe is not rotating smoothly or is swaying from side to side, adjust the stabilizer roller further inward. Continue the grooving operation and make further adjustments, as necessary. **DO NOT** adjust the stabilizer too far inward, since it will skew the pipe to the left and off center, resulting in excessive pipe-end flare.

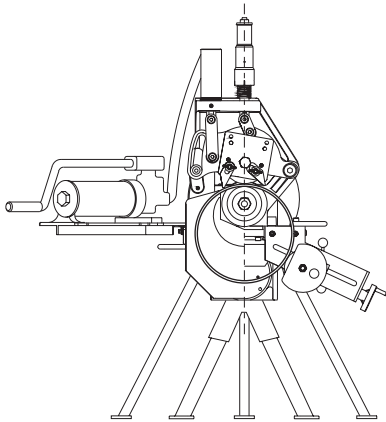

FIGURE 3 - "CORRECT"

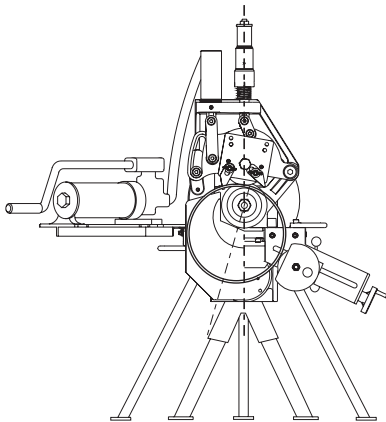

FIGURE 4 - "INCORRECT"

GROOVE DIAMETER STOP ADJUSTMENT

The groove diameter stop must be adjusted for each pipe size or change in wall thickness. The groove diameter, which is identified as the "C" dimension," is listed under the "Roll Groove Specifications" section. In addition, a label is affixed to the tool, which lists the "C" dimensions.

NOTICE

- **The groove diameter stop must be adjusted for each pipe size or change in wall thickness.**
- **The groove diameter, which is identified as the "C" dimension, is listed under the "Roll Groove Specifications" section.**
- **To perform the following adjustments, use several scrap sections of pipe that are the proper material, diameter, and thickness. Make sure the scrap sections meet the length requirements listed in Table 1.**

To achieve the proper diameter:

- a. Determine the diameter and thickness of the pipe to be grooved.
- b. Locate the proper pipe diameter and thickness on the pipe-size indicator label of the depth stop. The depth stop can be rotated for easy viewing.



1. Back off the depth adjuster lock. Align the top edge of the depth adjuster with the line down and to the right of the proper size and schedule markings, as shown above. Lock the depth adjuster in position with the depth adjuster lock.

NOTICE

- The markings provide an approximate groove diameter adjustment and are not exact groove diameter settings. Variations in pipe OD and wall thickness make it impossible to calibrate the groove diameter stop exactly.

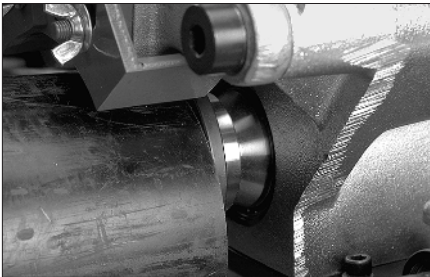

2. Insert a length of pipe over the lower roll with the pipe end against the lower-roll backstop flange.
3. Prepare a trial groove. Refer to the "Grooving Operation" section.

WARNING

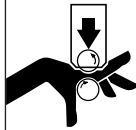

Grooving rolls can crush or cut fingers and hands.

- Before making any tool adjustments, always disconnect the power cord from the electrical source.

- Loading and unloading pipe will place your hands close to the rollers. Keep hands away from the grooving rolls during operation.
- Never reach inside the pipe end or across the tool or pipe during operation.
- Always groove pipe in a direction that rotates away from the operator.
- Never groove pipe that is shorter than the recommended lengths listed in this manual.
- Never wear loose clothing, loose gloves, or anything that can become entangled in moving parts.

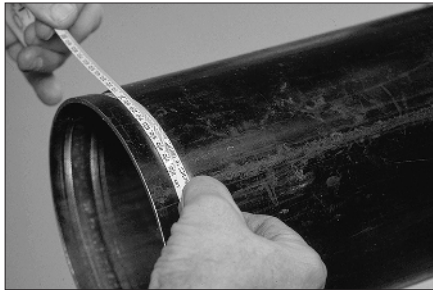

4. After a trial groove is prepared and the pipe is removed from the tool, carefully check the "C" dimension. Refer to "Roll Groove Specifications". The PT-100 Pipe Tape, supplied with the tool, is the best method for checking the "C" dimension. Alternately, a vernier caliper or narrow-land micrometer may be used to check this dimension at two locations (90° apart) around the groove. The average reading must be within the required groove diameter specification.

⚠ CAUTION

- The “C” dimension (groove diameter) and maximum allowable flare must conform to Victaulic specifications to ensure proper joint performance.
- The “C” dimension (groove diameter) must be within specification for the diameter and wall thickness of pipe. The groove diameter should be checked and adjusted, as necessary, to ensure grooves remain within specification.

Failure to follow these instructions could cause joint failure, resulting in personal injury and/or property damage.

- 5a. If the groove diameter (“C” dimension) is not within Victaulic specifications, the diameter stop must be adjusted.
- 5b. To adjust for a smaller groove diameter, turn the depth adjuster **counterclockwise** (when viewed from above the tool).
- 5c. To adjust for a larger groove diameter, turn the depth adjuster **clockwise** (when viewed from above the tool).

NOTE: A quarter turn either way will change the groove diameter adjustment by approximately 0.031 inch/0.8 mm. A full turn either way will change the groove diameter adjustment by approximately 0.125 inch/3.2 mm.

6. Prepare another trial groove, and check the groove diameter (“C” dimension), as described in step 4. Repeat these steps, as necessary, until the groove diameter is within specification.

GROOVING OPERATION

⚠ DANGER



- To reduce the risk of electric shock, check the electrical source for proper grounding.

- Before operating the tool, review the “Operator Safety Instructions” section of this manual.

Failure to follow these instructions could result in death or serious personal injury.

⚠ CAUTION

- This tool must be used **ONLY** for roll grooving pipe designated in the “Tool Rating and Roll Selection” section of this manual.

Failure to follow this instruction could overload the tool, resulting in reduced tool life and/or damage to the tool.

1. Before grooving, ensure that all instructions in the previous sections of this manual have been followed.
2. Plug the power drive into an internally grounded electrical source. **NOTE:** The power drive **MUST** be grounded. Refer to the power drive manufacturer’s instructions for detailed information.



- Set the power drive switch to produce **clockwise** rotation of the lower roll when viewed from the front of the tool. On the Victaulic VPD752 Power Drive and Ridgid 300 Power Drive, place the switch in the reverse position to produce clockwise rotation of the lower roll.

WARNING

- The power drive must be operated with a safety foot switch. If the power drive is not supplied with a safety foot switch, contact Victaulic.

Operating the tool without a safety foot switch could result in serious personal injury.

- Make sure the tool is operational by depressing the safety foot-switch pedal. The lower roll must turn **clockwise** when viewed from the front of the tool. Remove foot from the safety foot switch.



- Open the hand pump valve by turning the knob **counterclockwise**. Opening the hand pump valve will allow the upper roll and arm to move to the full up position.

WARNING

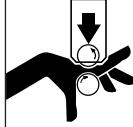

Grooving rolls can crush or cut fingers and hands.

- Before making any tool adjustments, always disconnect the power cord from the electrical source.
- Loading and unloading pipe will place your hands close to the rollers. Keep hands away from the grooving rolls during operation.
- Never reach inside the pipe end or across the tool or pipe during operation.
- Always groove pipe in a direction that rotates away from the operator.
- Never groove pipe that is shorter than the recommended lengths listed in this manual.
- Never wear loose clothing, loose gloves, or anything that can become entangled in moving parts.

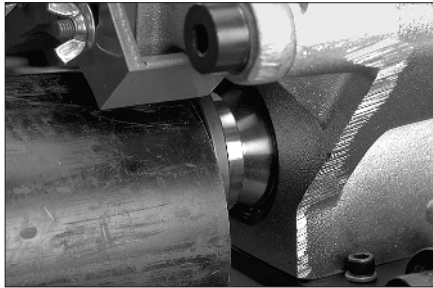

- Insert a length of pipe that is the correct size and thickness onto the lower roll. Make sure the pipe end contacts the lower-roll backstop flange completely. If the pipe is being supported with a pipe stand, remove hands from the pipe.



7. Close the hand pump valve by turning the knob **clockwise**.

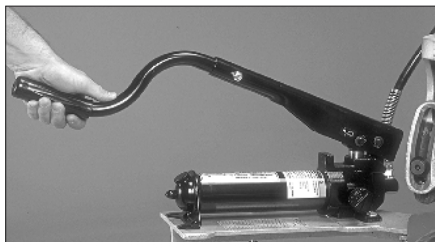

- 8a. Use the hand pump to bring the upper roll down into firm contact with the pipe.
- 8b. If grooving a short length of pipe, remove hands from the pipe. Refer to the "Short Pipe Lengths" section for requirements.

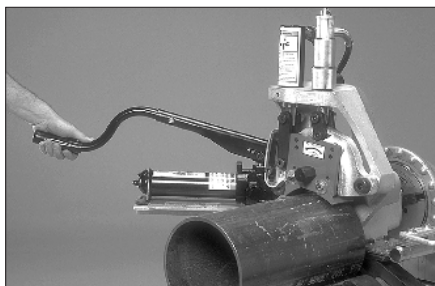

9. Depress and hold down the safety foot-switch pedal. The pipe will begin to rotate clockwise. As the pipe rotates, begin the grooving process by slowly pumping the handle of the hand pump.

NOTICE

- **DO NOT** pump the handle too fast. The rate should be sufficient to groove the pipe and maintain an audible, moderate-to-heavy load on the power drive motor.



10. Continue the grooving process until the depth stop makes firm contact with the top of the tool body. Continue to rotate the pipe for one to three revolutions to ensure groove completion.
- 11a. Release the safety foot switch pedal, and withdraw foot from the safety foot switch.

⚠ WARNING

- **DO NOT** place hands inside the pipe end or in the area of the grooving rolls or stabilizer roller while the pipe is still rotating.

Failure to follow these instructions could result in serious personal injury.

- 11b. If a short length of pipe is in the tool, manually support the pipe.



12. To release the pipe, open the hand pump valve by turning the knob counterclockwise. Remove the pipe from the tool.

NOTICE

- **The groove diameter must be within specification for the diameter and wall thickness of pipe. The groove diameter should be checked and adjusted, as necessary, to ensure grooves remain within specification.**

ROLL CHANGING

WARNING

- **Before making any tool adjustments, always disconnect the power cord from the electrical source.**

Accidental startup of the tool could result in serious personal injury.

The VE272SFS roll grooving tool is designed with rolls to accommodate several pipe sizes, which eliminates the need for frequent roll changes.

An upper roll and a “keyless” lower roll for 8 – 12-inch/200 – 300 mm steel pipe are factory installed on the tool. When 2 – 6-inch/ 50 – 150 mm steel pipe or other pipe materials are required for grooving, the upper and lower rolls must be changed. Refer to the following sections:

1. “Upper Roll Removal” section
2. “Lower Roll Removal for 2-inch/50 mm and Larger Sizes” section
3. “Lower Roll Installation for 2-inch/50 mm and Larger Sizes” section
4. “Upper Roll Installation” section

When 1½-inch/40 mm and smaller size steel pipe is required for grooving, the optional lower roll/adaptor assembly for ¾-inch/20 mm and 1 – 1½-inch/25 – 40 mm steel pipe must be ordered and installed. In addition, the correct upper roll for steel pipe must be installed. To accomplish this, the upper and lower rolls and the arbor for 2-inch/50 mm and larger sizes must be removed. Refer to the following sections:

1. “Upper Roll Removal” section
2. “Lower Roll Removal for 2-inch/50 mm and Larger Sizes” section
3. “Arbor Removal” section
4. “Lower Roll/Adapter Assembly Installation” section
5. “Upper Roll Installation” section

In addition, different pipe materials may require different rolls. For proper roll selection, refer to the “Tool Rating and Roll Selection” section.

LOWER ROLL REMOVAL FOR 2-INCH/ 50 MM AND LARGER SIZES



1. Open the hand pump valve by turning the knob **counterclockwise**. Opening the hand pump valve will allow the upper roll and arm to move to the full up position.

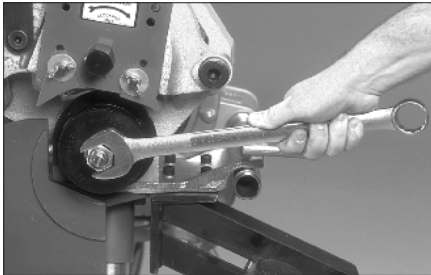

2. Using a wrench, loosen (**counterclockwise**) and remove the thin jam nut that secures the thicker nut onto the threaded stud of the arbor.

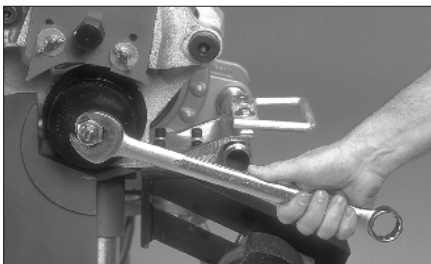

3. Using a wrench, loosen (**counterclockwise**) the thicker nut on the threaded stud of the arbor. Back off the nut approximately $\frac{1}{4}$ inch/6 mm without removing it from the threaded stud of the arbor.

WARNING



- **DO NOT** strike the lower roll/main shaft with a hammer or other blunt object.

Striking the lower roll/main shaft can cause fragmentation, resulting in serious personal injury.

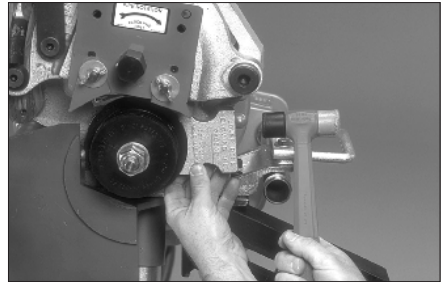

4. To loosen the lower roll from the arbor, use the aluminum wedge supplied with the tool. Place the aluminum wedge behind the lower roll, and strike the wedge with a soft-faced hammer to break the roll loose from the arbor. **DO NOT STRIKE THE ROLL DIRECTLY WITH A HAMMER.**

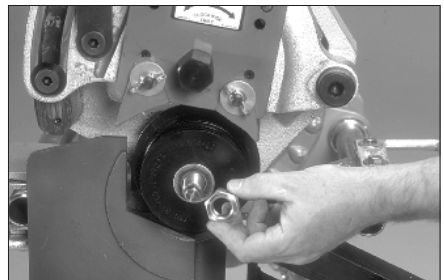

5. Remove the thick nut, washer, and lower roll. Store these items in a clean, dry location.

UPPER ROLL REMOVAL

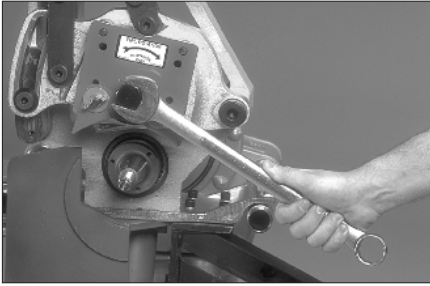

1. Using a wrench, loosen (**counterclockwise**) and remove the bolt from the upper roll. Store the bolt in a clean, dry location.

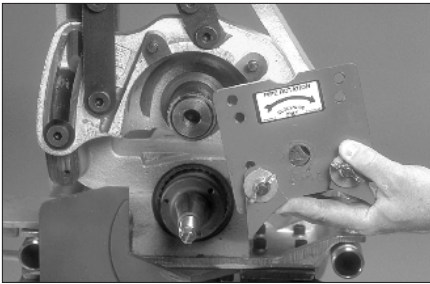

2. Remove the upper roll assembly. Store the upper roll in a clean, dry location.

ARBOR REMOVAL

This procedure is necessary for grooving smaller-size pipe or for replacing a damaged arbor. The standard arbor installed in the tool is specifically for 2 – 12-inch/50 – 300 mm pipe. When it is necessary to groove 1½-inch/40 mm and smaller size pipe, the optional lower roll/adaptor assembly must be ordered and installed.

1. Refer to the “Lower Roll Removal for 2-inch/50 mm and Larger Sizes” section to remove the lower roll.

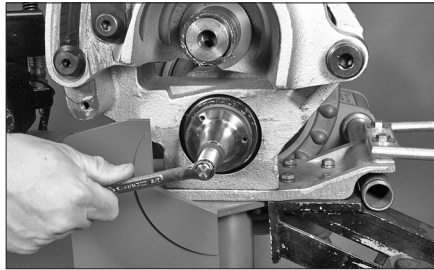

2. With a wrench engaged on the exposed hex-portion stud of the arbor, loosen the arbor by turning **counterclockwise**.
NOTE: The arbor should move outward as it is being loosened.

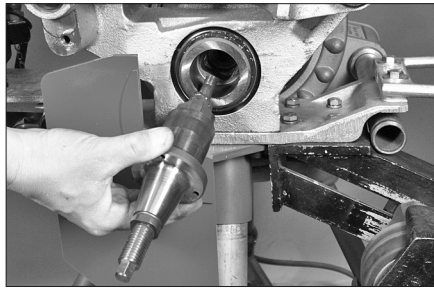

3. When the arbor has stopped moving outward, pull the arbor out of the tool. Store the arbor in a clean, dry location.

NOTICE

- If the arbor was insufficiently lubricated, it may be difficult to remove it from the drive shaft.
- The arbor features three ¼ – 20 UNC tapped holes so that jack bolts (not supplied) can be used to push the arbor out of the tool.

CAUTION

- **NEVER** operate the tool with jack bolts installed in the arbor.

Failure to follow this instruction will result in improper tool operation and tool damage.

NOTICE

- The $\frac{3}{4}$ -inch/20 mm and 1 – $1\frac{1}{2}$ -inch/25 – 40 mm lower roll/adaptor assembly is held in position with left-hand threads and must be tightened by turning **COUNTERCLOCKWISE**.

LOWER ROLL/ADAPTER ASSEMBLY INSTALLATION FOR $\frac{3}{4}$ -INCH/20 MM AND 1 – $1\frac{1}{2}$ -INCH/25 – 40 MM SIZES

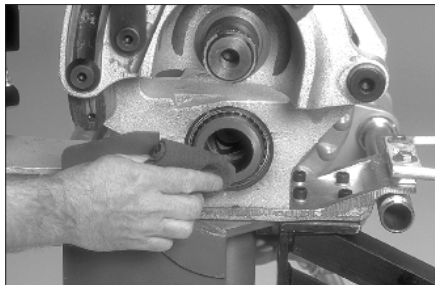

1. Using a soft cloth, clean the bore of the main shaft and the lower roll/adaptor assembly.



2. Lightly lubricate the lower roll/adaptor assembly with dry graphite spray (supplied with the tool and available from Victaulic).

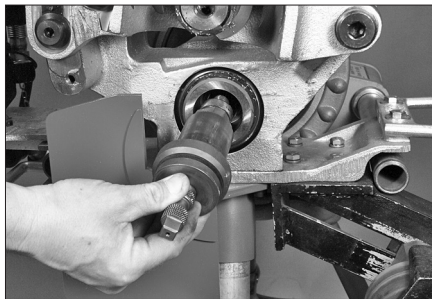

3. Carefully insert the lower roll/adaptor assembly into the main shaft. Make sure the lower roll/adaptor assembly is fully seated on the main shaft. It may be necessary to rotate the lower roll/adaptor assembly to align its square end with the square bore in the main shaft. Tighten the lower roll/adaptor assembly by turning **counterclockwise**.

UPPER ROLL INSTALLATION

Refer to the “Tool Rating and Roll Selection” section for information regarding grooving rolls.

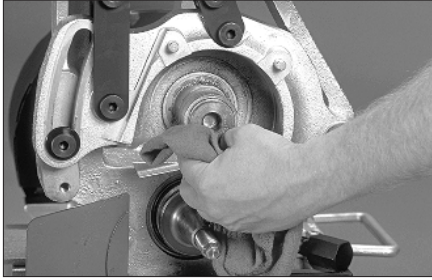

1. Before installing the upper roll, clean any dirt and scale from all shaft surfaces and roll bores.

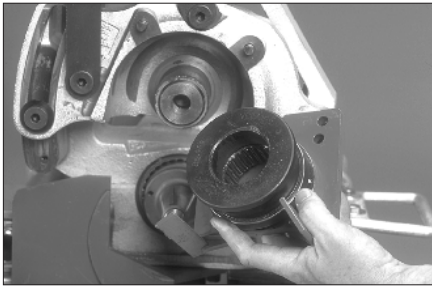

2. While the upper roll is removed from the tool, inspect the internal roller bearing for contamination, proper lubrication, and freedom of movement. In addition, inspect the guards for wear and freedom of movement. Repair or replace damaged components, as necessary.

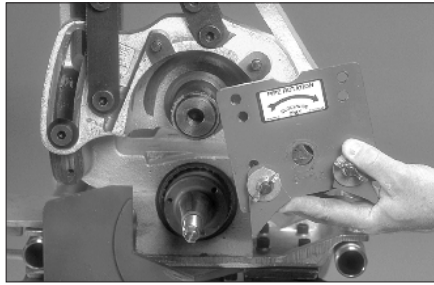

3. Carefully slide the desired upper roll assembly onto the upper shaft with the red plate facing out. Loosen the guards, if necessary, to ease installation. Make sure the red plate engages the two pins on the arm and that it contacts the front of the upper roll shaft.

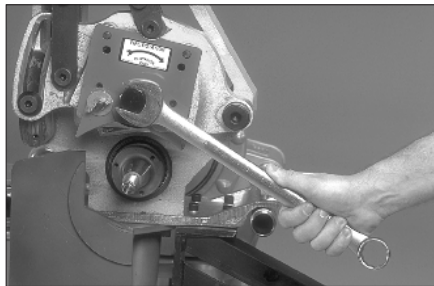

4. Insert the bolt for the upper roll. Tighten the bolt (**clockwise**) securely with a wrench.

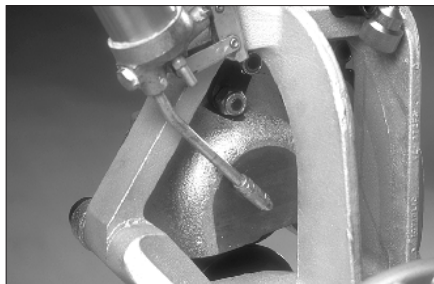

5. Lubricate the upper roll bearing. Refer to the “Maintenance” section for additional maintenance information.

**LOWER ROLL/ADAPTER ASSEMBLY
REMOVAL FOR 3/4-INCH/20 MM AND
1 – 1½-INCH/25 – 40 MM SIZES**



1. Open the hand pump valve by turning the knob **counterclockwise**. Opening the hand pump valve will allow the upper roll and arm to move to the full up position.

NOTICE

- The 3/4-inch/20 mm and 1 – 1½-inch/ 25 – 40 mm lower roll/adapter assembly is held in position with left-hand threads and must be removed by turning **CLOCKWISE**.



2. Using a wrench engaged on the square end of the lower roll/adapter assembly, remove the lower roll/adapter assembly by turning clockwise. Store the lower roll/adapter assembly in a clean, dry location.

ARBOR INSTALLATION

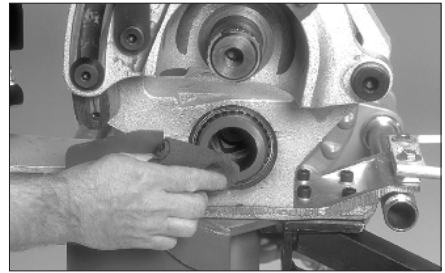

1. Using a soft cloth, clean the bore of the main shaft and the arbor.

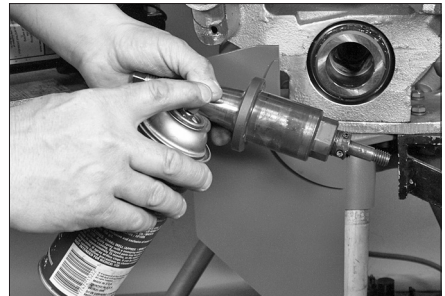

2. Lightly lubricate the arbor with dry graphite spray (supplied with the tool and available from Victaulic).



3. Carefully insert the arbor into the main shaft. Make sure the arbor is fully seated in the main shaft. It may be necessary to rotate the arbor to align its square end with the square bore in the main shaft. Tighten the arbor into the main shaft by turning the exposed hex-portion of the threaded stud **clockwise**.

- 4a. Install the lower roll for the correct size and pipe material by referring to the “Lower Roll Installation” section.
- 4b. Make sure the upper roll is installed for the correct pipe size and material.

LOWER ROLL INSTALLATION FOR 2-INCH/50 MM AND LARGER SIZES

NOTICE

- The arbor must be installed before attempting to install the lower roll. Refer to the “Arbor Installation” section.

CAUTION

- Ensure that the square drive flats of the roll are aligned properly with the square drive flats of the arbor.
- Make sure the thick nut is tightened securely onto the threaded stud of the arbor.

Failure to follow these instructions can result in the lower roll slipping on the arbor and causing damage to the arbor.

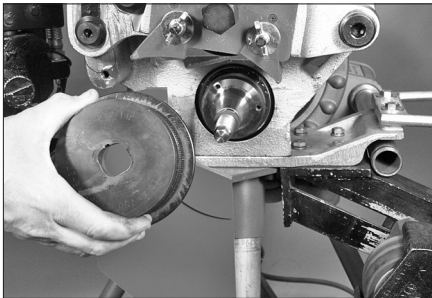

1. Place the lower roll onto the arbor. Re-position the roll guards, if necessary, to ease assembly. Make sure the lower roll fits fully onto the arbor. **NOTE:** The square drive flats of the roll must be aligned with the square drive flats of the arbor.

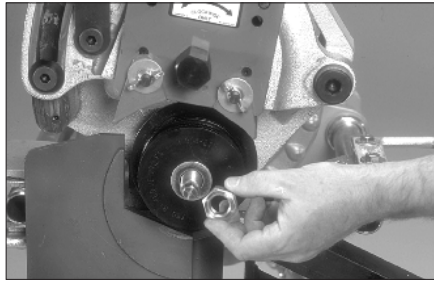

2. Install the flat washer and thick nut onto the threaded stud of the arbor in front of the lower roll. Tighten the thick nut **clockwise** securely with a wrench.

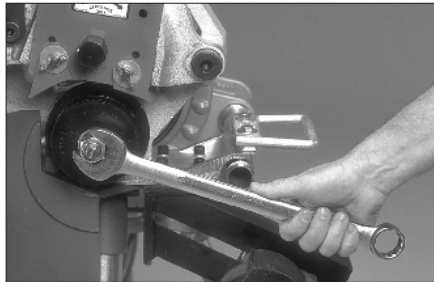

3. Install the thin jam nut onto the threaded stud of the arbor. Using a wrench, tighten the thin jam nut **clockwise** securely against the thick nut.



4. Close the hand pump valve by turning the knob **clockwise**.

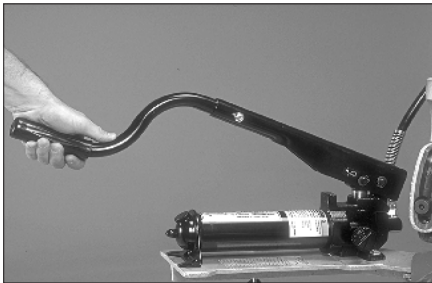



5. Pump the hand pump several times until the upper roll interlocks with the lower roll. This will confirm proper roll installation.



6. Open the hand pump valve by turning the knob **counterclockwise**.
7. Lower roll installation for 2-inch/50 mm and larger sizes is now complete. Before grooving, follow all steps in the “Pre-Operation Checks and Adjustments” section.

MAINTENANCE

 DANGER	
	<ul style="list-style-type: none"> • Before performing any maintenance on the tool, disconnect the power cord from the electrical source. <p>Failure to follow this instruction could result in death or serious personal injury.</p>

This section provides information about keeping tools in proper operating condition and guidance for making repairs, when necessary. Preventive maintenance during operation will pay for itself in repair and operating savings.

Replacement parts must be ordered from Victaulic to ensure proper and safe operation of the tool.

LUBRICATION

1. After every eight hours of operation, lubricate the machine. Always lubricate the upper roll bearings when rolls are changed.

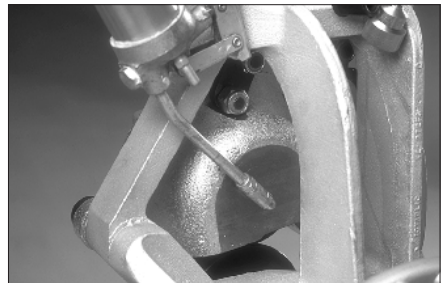

2. Grease the upper roll bearing at the grease fitting with a No. 2EP lithium-base grease, as shown above.

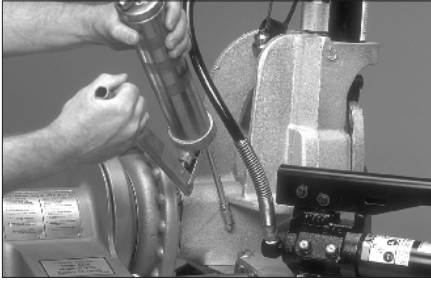

- Grease the main shaft bearings at the grease fitting with a No. 2EP lithium-base grease, as shown above.

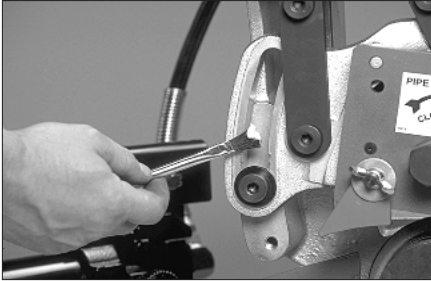

- Lubricate the linkage mechanisms, the arm pivot point, and the arm sliding surfaces with a heavy-duty spray lubricant, or grease may be applied by hand.

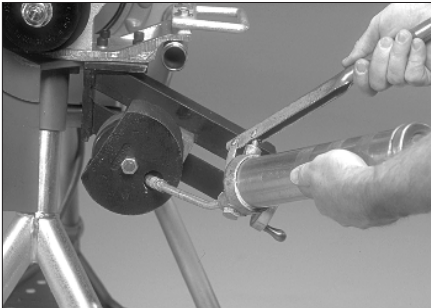

- For tools equipped with the optional pipe stabilizer:** Lubricate the stabilizer wheel with a No. 2EP lithium-base grease, as shown above.

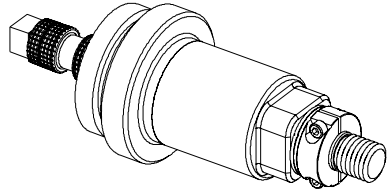

- After every forty hours of operation, clean and lubricate the $\frac{3}{4}$ -inch/20 mm lower roll (if equipped) and the 1 – $1\frac{1}{2}$ -inch/25 – 40 mm lower roll.

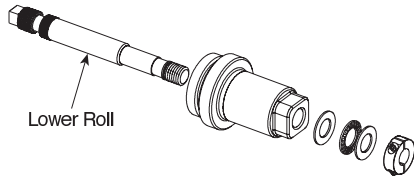

- Remove the cap screws, and disassemble the two-piece collar. Remove both the collar and the needle bearing, along with the washers.
- Remove the lower roll from the arbor. Clean the $\frac{3}{4}$ -inch/20 mm lower roll (if equipped) and the 1 – $1\frac{1}{2}$ -inch/25 – 40 mm lower roll. Lightly lubricate the lower rolls with dry graphite spray (supplied with the tool and available from Victaulic).

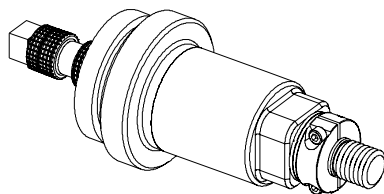

- Re-assemble the $\frac{3}{4}$ -inch/20 mm lower roll (if equipped) and the 1 – $1\frac{1}{2}$ -inch/25 – 40 mm lower roll. Lubricate the needle bearing with bearing grease. Make sure the end gaps are uniform on the two-piece collar.

CHECKING AND FILLING HYDRAULIC SYSTEMS

The hydraulic fluid level in the hand pump must be checked semi-annually or if the pump feels “spongy.”



1. Open the hand pump valve by turning the knob **counterclockwise**.

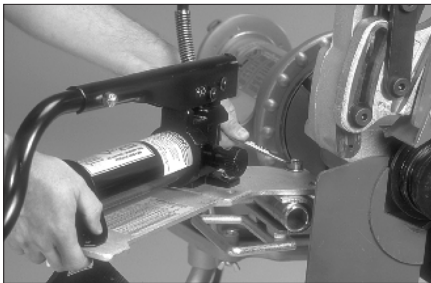

2. Remove the hand pump/pump support from the tool base.



3. Loosen, but do not remove, the hydraulic fill plug/dipstick at the back end of the pump.

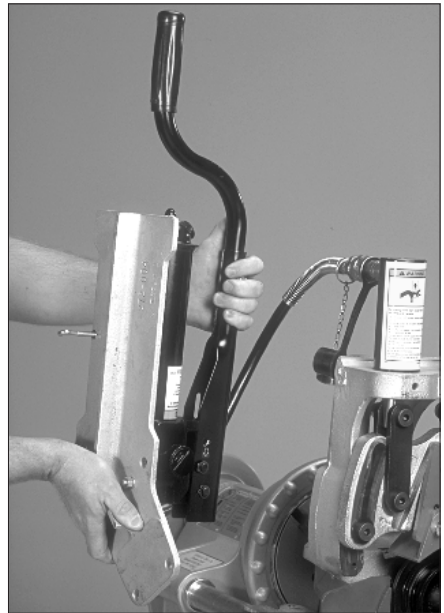

4. Hold the hand pump so that the fill plug end is **above** the hydraulic cylinder. This will prevent siphoning of oil from the hydraulic cylinder through the hand pump.
5. Check the fluid level. Add hydraulic jack oil (ISO 32) to the proper level, as required. On models without a dipstick, remove the cap. The oil should be approximately $\frac{1}{2}$ – 1 inch/13 – 25 mm from the end.

AIR BLEEDING

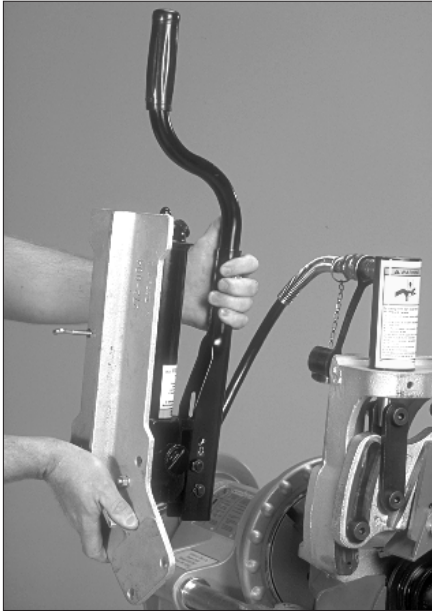

1. To bleed air from the system, hold the entire hand pump above the hydraulic cylinder. Close the hand pump valve by turning the knob **clockwise**. Open the fill plug one full turn.
2. Pump the hand pump several times to build pressure.
3. Open the hand pump valve by turning the knob **counterclockwise**, and allow air to escape.
4. Repeat steps 1 to 3 several times to bleed all air from the system.
5. Check the oil level. Add more oil, if necessary.
6. Continue to hold the pump above the hydraulic cylinder, and close the fill plug.
7. Install the hand pump/pump support securely to the tool by following steps 15 to 17 of the "Tool Setup" section.

PARTS ORDERING INFORMATION

When ordering parts, the following information is required for Victaulic to process the order and send the correct part(s). Request the RP-272SFS Repair Parts List for detailed drawings and parts listings.

1. Tool Model Number – VE272SFS
2. Tool Serial Number – The serial number is stamped onto the tool body
3. Quantity, Part Number, and Description – For example, (1), R029266MCH, Main Shaft
4. Where to Send the Part(s) – Company name and address
5. To Whose Attention to Send the Part(s)
6. Purchase Order Number

Order parts from Victaulic at the address listed in this manual.

ACCESSORIES

VAPS 112 VICTAULIC ADJUSTABLE PIPE STAND



The Victaulic VAPS 112 is a portable, adjustable, roller-type pipe stand that contains four legs for additional stability. Ball transfer rollers, adjustable for $\frac{3}{4}$ – 12-inch/20 – 300 mm pipe, accommodate linear and rotational movement. The turnstile design permits ease of grooving for both pipe ends. Contact Victaulic for details.

VAPS 224 VICTAULIC ADJUSTABLE PIPE STABILIZER ASSEMBLY STAND



The Victaulic VAPS 224 contains features that are similar to the VAPS 112, but it is suitable for 2 – 24-inch/50 – 600 mm pipe sizes. Contact Victaulic for details.

VPD752 POWER DRIVE



The Victaulic VPD752 Power Drive can be used as the power drive unit for several different roll grooving tool models with the correct base plate. The power drive utilizes a 60 Hz universal motor and requires 115V/1 Phase, 15 amps of power. A safety foot switch is included for proper operation. Contact Victaulic for details.

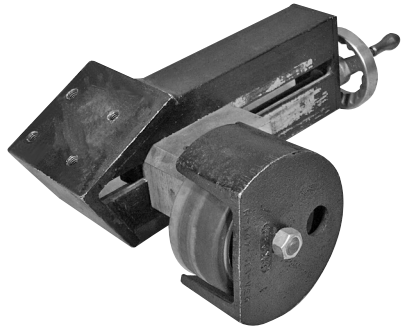

A pipe stabilizer is available to prevent pipe sway on 8 – 12-inch/200 – 300 mm pipe sizes. Contact Victaulic for details.

OPTIONAL ROLLS

Refer to the “Tool Rating and Roll Selection” section for rolls that are available for different materials and groove specifications.

This page intentionally blank

TROUBLESHOOTING

PROBLEM	POSSIBLE CAUSE	SOLUTION
Pipe will not stay in grooving rolls.	Incorrect pipe positioning of long pipe length.	Refer to the "Long Pipe Lengths" section.
	Lower roll and pipe are not rotating clockwise.	Flip the switch on the power drive to the opposite rotation position.
Pipe stops rotating during grooving.	Rust or dirt buildup is present on the lower roll.	Remove rust or dirt accumulation from the lower roll with a stiff wire brush.
	Rust or dirt is excessively heavy inside the pipe end.	Remove heavy rust and dirt from inside the pipe end.
	Worn grooving rolls.	Inspect the lower roll for worn knurls. Replace the lower roll if excessive wear is present.
	Power drive has stalled due to excessive pumping of the hand pump.	Support the pipe. Open the hand pump valve by turning the knob counterclockwise. Close the hand pump valve by turning the knob clockwise. Continue grooving by pumping the hand pump at a moderate rate.
	The circuit breaker has tripped or a fuse has blown out on the electrical circuit that supplies the power drive.	Reset the breaker, or replace the fuse.
The tool will not groove the pipe.	Pipe is beyond the wall thickness capacity of the tool.	Refer to the "Tool Ratings" section.
While grooving, loud squeaks or echo	Pipe material is excessively hard.	Refer to the "Tool Ratings" section.
	Incorrect pipe support positioning of long pipe. Pipe is "over-tracking."	Move the pipe support to the right. Refer to the "Long Pipe Lengths" section.
	Pipe end is not cut square.	Cut the pipe end squarely.
	Pipe is rubbing excessively on the lower roll backstop flange.	Remove the pipe from the tool, and apply a light coating of grease to the face of the lower roll backstop flange, as needed.
During grooving, loud thumps or bangs occur approximately once every revolution of the pipe.	Pipe has a pronounced weld seam.	Grind the raised welds flush with the interior and exterior pipe surfaces 2 inches (50 mm) back from the pipe end.

TROUBLESHOOTING (CONTINUED)

PROBLEM	POSSIBLE CAUSE	SOLUTION
Pipe flare is excessive.	Pipe support adjusted too high for long pipe.	Refer to the "Long Pipe Lengths" section.
	Tool is tilted forward (out of level) while grooving long pipe.	Refer to the "Tool Setup" section.
	Incorrect pipe support positioning of long pipe. Pipe is "over-tracking".	Move the pipe support to the right. Refer to the "Long Pipe Lengths" section.
	Pipe stabilizer is adjusted too far inward.	Back off the pipe stabilizer to the furthest point where it still stabilizes the pipe effectively.
Larger diameter pipe sways or vibrates from side to side.	Incorrect pipe stabilizer adjustment.	Move the pipe stabilizer in or out until the pipe rotates smoothly.
	Optional pipe stabilizer was not purchased, installed, or used.	Purchase, install, or use the optional pipe stabilizer.
The tool will not groove the pipe.	Hand pump valve is not closed tightly.	Tighten the hand pump valve by turning the knob clockwise.
	Improper feed rate.	Advance the feed at the rate specified in the "Grooving Operation" section.
	Hand pump is low on oil.	Refer to the "Maintenance" section.
	Air is present in the hydraulic system.	Refer to the "Maintenance" section.
	Pipe is beyond the wall thickness capacity of the tool.	Refer to the "Tool Rating and Roll Selection" section.
Pipe grooves do not meet Victaulic specifications.	Groove diameter stop is not adjusted correctly.	Refer to the "Groove Diameter Stop Adjustment" section.
	Pipe is beyond the wall thickness capacity of the tool.	Refer to the "Tool Rating and Roll Selection" section.
The "A" Gasket Seat or "B" Groove Width dimensions do not meet Victaulic specifications.	Upper roll bearing is not lubricated adequately.	Refer to the "Maintenance" section.
	Incorrect upper roll, lower roll, or both installed on the tool.	Install the correct rolls. Refer to the "Tool Rating and Roll Selection" section.

In the event of tool malfunction outside the scope of the troubleshooting section, contact Victaulic Engineering Services for assistance.

TOOL RATING AND ROLL SELECTION

ORIGINAL GROOVE SYSTEM AND “ES” ROLLS FOR STEEL AND STAINLESS STEEL PIPE – COLOR-CODED BLACK

(For light-wall stainless steel pipe, refer to separate table)

Pipe Size		Dimensions - inches/millimeters				OGS Roll Part Numbers	“ES” Roll Part Numbers
Nominal Size inches or mm	Actual Outside Diameter inches/mm	Steel Pipe Wall Thickness †		Stainless Steel Pipe Wall Thickness *			
		Minimum	Maximum	Minimum	Maximum		
¾	1.050 26.9	0.065 1.7	0.113 2.9	0.065 1.7	0.113 2.9	Lower Roll R9A0268L01 Upper Roll R9A0268U02	—
1	1.315 33.7	0.065 1.7	0.133 3.4	0.065 1.7	0.133 3.4	Lower Roll R9A1268L02 Upper Roll R9A0268U02	—
1¼	1.660 42.4	0.065 1.7	0.140 3.6	0.065 1.7	0.140 3.6		
1½	1.900 48.3	0.065 1.7	0.145 3.7	0.065 1.7	0.145 3.7		
2	2.375 60.3	0.065 1.7	0.154 3.9	0.154 3.9	0.154 3.9	Lower Roll R902272L03	Lower Roll RZ02272L03
2½	2.875 73.0	0.083 2.1	0.203 5.2	0.203 5.2	0.203 5.2		
3	3.500 88.9	0.083 2.1	0.216 5.5	0.216 5.5	0.216 5.5	Upper Roll R9A2268U06	Upper Roll RZA2268U03
3½	4.000 101.6	0.083 2.1	0.226 5.7	0.226 5.7	0.226 5.7		
4	4.500 114.3	0.083 2.1	0.375 9.5	0.237 6.0	0.237 6.0	Lower Roll R904272L06	Lower Roll RZ04272L06
4½	5.000 127.0	0.095 2.4	0.375 9.5	0.237 6.0	0.237 6.0		
5	5.563 141.3	0.109 2.8	0.375 9.5	0.258 6.6	0.258 6.6	Upper Roll R9A2268U06	Upper Roll RZA2268U06
152.4mm	6.000 152.4	0.109 2.8	0.258 6.6	0.258 6.6	0.258 6.6		
6	6.625 168.3	0.109 2.8	0.375 9.5	0.280 7.1	0.280 7.1	Lower Roll R908272L12	Lower Roll RZ08272L12
203.2mm	8.000 203.2	0.109 2.8	0.322 8.2	0.250 6.4	0.322 8.2		
8	8.625 219.1	0.109 2.8	0.375 9.5	0.250 6.4	0.322 8.2	Upper Roll R9A8268U12	Upper Roll RZA8268U12
10	10.750 273.0	0.134 3.4	0.375 9.5	0.250 6.4	0.365 9.3		
12	12.750 323.9	0.156 4.0	0.375 9.5	0.250 6.4	0.375 9.5		

† Maximum ratings on steel are limited to pipe of a Brinell Hardness Number (BHN) of 180 BHN and less

* Types 304/304L and 316/316L stainless steel pipe

In addition, the following pipe sizes may be roll grooved: 76.1 mm; 108.0 mm; 127.0 mm; 133.0 mm; 139.7 mm; 159.0 mm; 165.1 mm; 216.3 mm; 267.4 mm; and 318.5 mm. Contact Victaulic for details.

**ORIGINAL GROOVE SYSTEM ROLLS FOR ALUMINUM AND PVC PLASTIC PIPE –
COLOR-CODED YELLOW ZINC**

Pipe Size		Dimensions - inches/millimeters				Roll Part Numbers
Nominal Size inches or mm	Actual Outside Diameter inches/mm	Aluminum Pipe Wall Thickness †		PVC Plastic Pipe Wall Thickness *		
		Minimum	Maximum	Minimum	Maximum	
2	2.375 60.3	0.065 1.7	0.154 3.9	0.154 3.9	0.154 3.9	Lower Roll R902272L03 Upper Roll RP02272U06
2½	2.875 73.0	0.083 2.1	0.203 5.2	0.203 5.2	0.276 7.0	
3	3.500 88.9	0.083 2.1	0.216 5.5	0.216 5.5	0.300 7.6	
3½	4.000 101.6	0.083 2.1	0.226 5.7	0.226 5.7	0.318 8.1	Lower Roll R904272L06 Upper Roll RP02272U06
4	4.500 114.3	0.083 2.1	0.237 6.0	0.237 6.0	0.337 8.6	
4½	5.000 127.0	0.095 2.4	0.237 6.0	—	—	
5	5.563 141.3	0.109 2.8	0.258 6.6	0.258 6.6	0.375 9.5	
152.4 mm	6.000 152.4	0.109 2.8	0.258 6.6	—	—	
6	6.625 168.3	0.109 2.8	0.280 7.1	0.280 7.1	0.432 11.0	

† Alloys 6061-T4 and 6063-T4

* PVC Type 1. Grade 1 – PVC 1120; PVC Type 1. Grade II – PVC 1220; PVC Type II. Grade I – PVC 2116

The wall thicknesses listed are nominal minimum and maximum

In addition, the following pipe sizes may be roll grooved: 76.1 mm; 108.0 mm; 133.0 mm; 139.7 mm; 159.0 mm; and 165.1 mm. Contact Victaulic for details.

A special lower roll is available for grooving 2-inch Schedule 80 PVC plastic pipe (part number RP02272L02). Contact Victaulic for details.

**RX ROLLS FOR SCHEDULE 5S AND 10S STAINLESS STEEL PIPE –
COLOR-CODED SILVER**

Pipe Size		Dimensions - inches/millimeters		RX Roll Part Numbers
Nominal Size inches	Actual Outside Diameter inches/mm	Stainless Steel Pipe † Wall Thickness		
		Minimum	Maximum	
2	2.375 60.3	0.065 1.7	0.109 2.8	Lower Roll RX02272L03
2½	2.875 73.0	0.083 2.1	0.120 3.0	
3	3.500 88.9	0.083 2.1	0.120 3.0	Upper Roll RXA2268U06
3½	4.000 101.6	0.083 2.1	0.120 3.0	
4	4.500 114.3	0.083 2.1	0.120 3.0	Lower Roll RX04272L06
5	5.563 141.3	0.109 2.8	0.134 3.4	
6	6.625 168.3	0.109 2.8	0.134 3.4	Upper Roll RXA2268U06
8	8.625 219.1	0.109 2.8	0.148 3.8	
10	10.750 273.0	0.134 3.4	0.165 4.2	Lower Roll RX08272L12
12	12.750 323.9	0.156 4.0	0.180 4.6	

† Types 304/304L and 316/316L stainless steel pipe

The wall thicknesses listed are nominal minimum and maximum

In addition, the following pipe sizes may be roll grooved: 76.1 mm; 108.0 mm; 133.0 mm; 139.7 mm; 152.4 mm; 159.0 mm; 165.1 mm; and 203.2 mm. Contact Victaulic for details.

**ROLLS FOR CTS US STANDARD – ASTM DRAWN COPPER TUBING –
COLOR-CODED COPPER**

Pipe Size		Dimensions – inches/millimeter		Copper Roll Part Numbers
Nominal Size inches	Actual Outside Diameter inches/mm	Copper Tubing Wall Thickness †		
		Minimum	Maximum	
2	2.125 54.0	0.042 1.1	0.083 2.1	Lower Roll RR02272L06 Upper Roll RRA2268U08
2½	2.625 66.7	0.065 1.7	0.095 2.4	
3	3.125 79.4	0.045 1.1	0.109 2.8	
4	4.125 104.8	0.058 1.5	0.134 3.4	
5	5.125 130.2	0.072 1.8	0.160 4.1	
6	6.125 155.6	0.083 2.1	0.192 4.9	
8	8.125 206.4	0.109 2.8	0.271 6.9	Lower Roll RR08272L0 Upper Roll RRA2268U08

† ASTM B-306, Type DWV and ASTM B-88, Types K, L, M copper tubing

The wall thicknesses listed are nominal minimum and maximum

ROLLS FOR EUROPEAN STANDARD – EN 1057 DRAWN COPPER TUBING – COLOR-CODED COPPER

Nominal Size mm	Dimensions – millimeters/inches		Copper Roll Part Numbers
	Copper Tubing Wall Thickness †		
	Minimum	Maximum	
54.0	1.2 0.047	2.0 0.079	Lower Roll RRE1272L06 Upper Roll RRE1272U06
64.0	2.0 0.079	2.0 0.079	
66.7	1.2 0.047	2.0 0.079	
76.1	1.5 0.059	2.0 0.079	
88.9	2.0 0.079	2.0 0.079	
108.0	1.5 0.059	2.5 0.098	
133.0	1.5 0.059	3.0 0.118	
159.0	2.0 0.079	3.0 0.118	

† The European Standard (EN 1057) replaces the British Standard (BS 2871) and DIN Standard (DIN 1786). However, to ensure proper product performance, refer to Tables X and Y in the British Standard (BS 2871).

**ROLLS FOR AUSTRALIAN STANDARD – AS 1432 DRAWN COPPER TUBING –
COLOR CODED COPPER**

Nominal Size mm	Dimensions – millimeters/inches		Copper Roll Part Numbers
	Copper Tubing Wall Thickness †		
	Minimum	Maximum	
DN 50	0.9 0.035	1.6 0.063	Lower Roll RRE1272L06 Upper Roll RRE1272U06
DN 65	0.9 0.035	1.6 0.063	
DN 80	1.2 0.047	2.0 0.079	
DN 100	1.2 0.047	2.0 0.079	
DN 125	1.4 0.055	2.0 0.079	
DN 150	1.6 0.063	2.6 0.102	

† Types A, B, and D

EXPLANATION OF CRITICAL ROLL GROOVE DIMENSIONS FOR ORIGINAL GROOVE SYSTEM (OGS) PRODUCTS

WARNING

- Pipe dimensions and groove dimensions must be within the tolerances specified in the tables on the following pages to ensure proper joint performance.

Failure to follow these specifications could cause joint failure, resulting in serious personal injury and/or property damage.

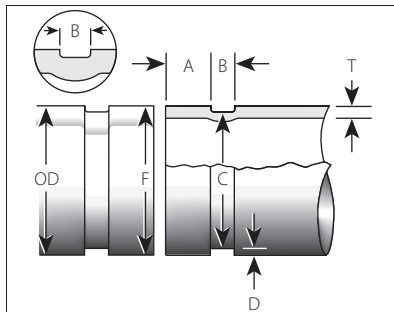

STANDARD ROLL GROOVE

Illustration is exaggerated for clarity

NOTICE

FOR STANDARD COUPLINGS WITH RATINGS ON LIGHT-WALL STAINLESS STEEL PIPE:

- Victaulic RX rolls **MUST** be used when roll grooving light-wall stainless steel pipe for use with standard couplings.

Pipe Outside Diameter – Nominal NPS Pipe Size (ANSI B36.10) and Basic Metric Pipe Size (ISO 4200) – The average pipe outside diameter must not vary from the specifications listed in the tables on the following pages. Maximum allowable pipe ovality shall comply with the requirements of ASTM A-999 and API 5L. Greater variations between the major and minor diameters will result in difficult coupling assembly.

For NPS pipe, the maximum allowable tolerance from square-cut pipe ends is: $\frac{1}{16}$ inch/1.6 mm for 4 to 24-inch/114.3 to 610-mm sizes and $\frac{3}{32}$ inch/2.4 mm for 26-inch/660-mm and larger sizes. This is measured from the true square line.

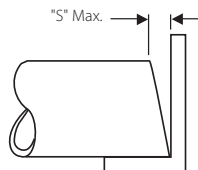

Any internal and external weld beads or seams must be ground flush to the pipe surface. The inside diameter of the pipe end must be cleaned to remove coarse scale, dirt, and other foreign material that might interfere with or damage grooving rolls. The front edge of the pipe end shall be uniform with no concave/convex surface features that will cause improper grooving roll tracking or result in difficulties during coupling assembly.

“A” Dimension – The “A” dimension, or the distance from the pipe end to the groove, identifies the gasket seating area. This area must be free from indentations, projections (including weld seams), and roll marks from the pipe end to the groove to ensure a leak-tight seal. All foreign material, such as loose paint, scale, oil, grease, chips, rust, and dirt must be removed.

“B” Dimension – The “B” dimension, or groove width, controls expansion, contraction, and angular deflection of flexible couplings by the distance it is located from the pipe and its width in relation to the coupling housings’ “key” width. The bottom of the groove must be free of all foreign material, such as dirt, chips, rust, and scale that may interfere with proper coupling assembly.

“C” Dimension – The “C” dimension is the average diameter at the base of the groove. This dimension must be within the diameter’s tolerance and concentric with the OD for proper coupling fit. The groove must be of uniform depth for the entire pipe circumference.

“D” Dimension – The “D” dimension is the normal depth of the groove and is a reference for a “trial groove” only. Variations in pipe OD affect this dimension and must be altered, if necessary, to keep the “C” dimension within tolerance. The groove diameter must conform to the “C” dimension described above.

“F” Dimension – Maximum allowable pipe-end flare diameter is measured at the extreme pipe-end diameter. **NOTE:** This applies to average (pi tape) and single-point readings.

“T” Dimension – The “T” dimension is the lightest grade (minimum nominal wall thickness) of pipe that is suitable for cut or roll grooving. Pipe that is less than the minimum nominal wall thickness for cut grooving may be suitable for roll grooving or adapted for Victaulic couplings by using Vic-Ring® Adapters. Vic-Ring Adapters can be used in the following situations (contact Victaulic for details):

- When pipe is less than the minimum nominal wall thickness suitable for roll grooving
- When pipe outside diameter is too large to roll or cut groove
- When pipe is used in abrasive services

NOTICE

- **Coatings that are applied to the interior surfaces of Victaulic grooved and plain-end pipe couplings must not exceed 0.010 inch/0.25 mm. This includes the bolt pad mating surfaces.**
- **In addition, the coating thickness applied to the gasket-sealing surface and within the groove on the pipe exterior must not exceed 0.010 inch/0.25 mm.**

**ROLL GROOVE SPECIFICATIONS
STEEL, STAINLESS STEEL, ALUMINUM, AND PVC PIPE**

Pipe Size		Dimensions – inches/millimeters												
Nominal Size inches/mm	Actual Outside Diameter inches/mm	Pipe Outside Diameter		Gasket Seat "A"		Groove Width "B"				Groove Diameter "C"		Groove Depth "D" (ref.)	Min. Allow. Wall Thick. "T"*	Max. Allow. Flare Dia. "F"
		Max.	Min.	Basic	Max.	Min.	Basic	Max.	Min.	Max.	Min.			
¾ 20	1.050	1.060	1.040	0.625	0.656	0.594	0.281	0.312	0.250	0.938	0.923	0.056	0.049	1.15
	26.9	26.9	26.4	15.9	16.7	15.1	7.1	7.9	6.4	23.8	23.4	1.5	1.2	29.2
1 25	1.315	1.328	1.302	0.625	0.656	0.594	0.281	0.312	0.250	1.190	1.175	0.063	0.049	1.43
	33.7	33.7	33.1	15.9	16.7	15.1	7.1	7.9	6.4	30.2	29.9	1.6	1.2	36.3
1¼ 32	1.660	1.676	1.644	0.625	0.656	0.594	0.281	0.312	0.250	1.535	1.520	0.063	0.049	1.77
	42.4	42.4	41.8	15.9	16.7	15.1	7.1	7.9	6.4	39.0	38.6	1.6	1.2	45.0
1½ 40	1.900	1.919	1.881	0.625	0.656	0.594	0.281	0.312	0.250	1.775	1.760	0.063	0.049	2.01
	48.3	48.7	47.8	15.9	16.7	15.1	7.1	7.9	6.4	45.1	44.7	1.6	1.2	51.1
2 50	2.375	2.399	2.351	0.625	0.656	0.594	0.344	0.375	0.313	2.250	2.235	0.063	0.049	2.48
	60.3	60.9	59.7	15.9	16.7	15.1	8.7	9.5	8.0	57.2	56.8	1.6	1.2	63.0
2½ 65	2.875	2.904	2.846	0.625	0.656	0.594	0.344	0.375	0.313	2.720	2.702	0.078	0.078	2.98
	73.0	73.8	72.3	15.9	16.7	15.1	8.7	9.5	8.0	69.1	68.6	2.0	2.0	75.7
76.1 mm	3.000	3.030	2.970	0.625	0.656	0.594	0.344	0.375	0.313	2.845	2.827	0.078	0.078	3.10
	76.1	77.0	75.4	15.9	16.7	15.1	8.7	9.5	8.0	72.3	71.8	2.0	2.0	78.7
3 80	3.500	3.535	3.469	0.625	0.656	0.594	0.344	0.375	0.313	3.344	3.326	0.078	0.078	3.60
	88.9	89.8	88.1	15.9	16.7	15.1	8.7	9.5	8.0	84.9	84.5	2.0	2.0	91.4
3½ 90	4.000	4.040	3.969	0.625	0.656	0.594	0.344	0.375	0.313	3.834	3.814	0.083	0.078	4.10
	101.6	102.6	100.8	15.9	16.7	15.1	8.7	9.5	8.0	97.4	96.9	2.2	2.0	104.1
108.0 mm	4.250	4.293	4.219	0.625	0.656	0.594	0.344	0.375	0.313	4.084	4.064	0.083	0.078	4.35
	108.0	109.0	107.2	15.9	16.7	15.1	8.7	9.5	8.0	103.7	103.2	2.2	2.0	110.5
4 100	4.500	4.545	4.469	0.625	0.656	0.594	0.344	0.375	0.313	4.334	4.314	0.083	0.078	4.60
	114.3	115.4	113.5	15.9	16.7	15.1	8.7	9.5	8.0	110.1	109.6	2.2	2.0	116.8
4½ 120	5.000	5.050	4.969	0.625	0.656	0.594	0.344	0.375	0.313	4.834	4.814	0.083	0.078	5.10
	127.0	128.3	126.2	15.9	16.7	15.1	8.7	9.5	8.0	122.8	122.3	2.2	2.0	129.5

Table continued on the following page.

STEEL, STAINLESS STEEL, ALUMINUM, AND PVC PIPE (CONTINUED)

Pipe Size		Dimensions – inches/millimeters												
Nominal Size inches/mm	Actual Outside Diameter inches/mm	Pipe Outside Diameter		Gasket Seat "A"			Groove Width "B"			Groove Diameter "C"		Groove Depth "D" (ref.)	Min. Allow. Wall Thick. "T" ¹	Max. Allow. Flare Dia. "F"
		Max.	Min.	Basic	Max.	Min.	Basic	Max.	Min.	Max.	Min.			
133.0 mm	5.250	5.303	5.219	0.625	0.656	0.594	0.344	0.375	0.313	5.084	5.064	0.083	0.078	5.35
	134.7	132.6	132.6	15.9	16.7	15.1	8.7	9.5	8.0	129.1	128.6	2.2	2.0	135.9
139.7 mm	5.500	5.556	5.469	0.625	0.656	0.594	0.344	0.375	0.313	5.334	5.314	0.083	0.078	5.60
	139.7	141.1	138.9	15.9	16.7	15.1	8.7	9.5	8.0	135.5	135.0	2.2	2.0	142.2
5	5.563	5.619	5.532	0.625	0.656	0.594	0.344	0.375	0.313	5.395	5.373	0.084	0.078	5.66
125	141.3	142.7	140.5	15.9	16.7	15.1	8.7	9.5	8.0	137.0	136.5	2.2	2.0	143.8
152.4 mm	6.000	6.056	5.969	0.625	0.656	0.594	0.344	0.375	0.313	5.830	5.808	0.085	0.078	6.10
	152.4	153.8	151.6	15.9	16.7	15.1	8.7	9.5	8.0	148.1	147.5	2.2	2.0	154.9
159.0 mm	6.250	6.313	6.219	0.625	0.656	0.594	0.344	0.375	0.313	6.032	6.002	0.109	0.109	6.35
	159.0	160.4	158.0	15.9	16.7	15.1	8.7	9.5	8.0	153.2	152.5	2.8	2.8	161.3
165.1 mm	6.500	6.563	6.469	0.625	0.656	0.594	0.344	0.375	0.313	6.330	6.308	0.085	0.078	6.60
	165.1	166.7	164.3	15.9	16.7	15.1	8.7	9.5	8.0	160.8	160.2	2.2	2.0	167.6
6	6.625	6.688	6.594	0.625	0.656	0.594	0.344	0.375	0.313	6.455	6.433	0.085	0.078	6.73
150	168.3	169.9	167.5	15.9	16.7	15.1	8.7	9.5	8.0	164.0	163.4	2.2	2.8	170.9
203.2 mm	8.000	8.063	7.969	0.750	0.781	0.719	0.469	0.500	0.438	7.816	7.791	0.092	0.109	8.17
	203.2	204.8	202.4	19.1	19.8	18.3	11.9	12.7	11.1	198.5	197.9	2.4	2.8	207.5
216.3 mm	8.515	8.578	8.484	0.750	0.781	0.719	0.469	0.500	0.438	8.331	8.306	0.092	0.109	8.69
	216.3	217.9	215.5	19.1	19.8	18.3	11.9	12.7	11.1	211.6	211.0	2.4	2.8	220.7
8	8.625	8.688	8.594	0.750	0.781	0.719	0.469	0.500	0.438	8.441	8.416	0.092	0.109	8.80
200	219.1	220.7	218.3	19.1	19.8	18.3	11.9	12.7	11.1	214.4	213.8	2.4	2.8	223.5
254.0 mm	10.000	10.063	9.969	0.750	0.781	0.719	0.469	0.500	0.438	9.812	9.785	0.094	0.134	10.17
	254.0	255.6	253.2	19.1	19.8	18.3	11.9	12.7	11.1	249.2	248.5	2.4	3.4	258.3
267.4 mm	10.528	10.591	10.497	0.750	0.781	0.719	0.469	0.500	0.438	10.340	10.313	0.094	0.134	10.70
	267.4	269.0	266.6	19.1	19.8	18.3	11.9	12.7	11.1	262.6	262.0	2.4	3.4	271.8

Table continued on the following page.

STEEL, STAINLESS STEEL, ALUMINUM, AND PVC PIPE (CONTINUED)

Pipe Size		Dimensions – inches/millimeters											
Nominal Size inches/ mm	Actual Outside Diameter inches/mm	Pipe Outside Diameter		Gasket Seat "A"		Groove Width "B"			Groove Diameter "C"		Groove Depth "D" (ref.)	Min. Allow. Wall Thick. "r" ¹ **	Min. Allow. Flare Dia. "F"
		Max.	Min.	Basic	Max.	Min.	Max.	Min.	Max.				
10 250	10.750	10.813	10.719	0.750	0.781	0.719	0.469	0.500	0.438	10.535	0.094	0.134	10.92
	273.0	274.7	272.3	19.1	19.8	18.3	11.9	12.7	11.1	268.3	2.4	3.4	277.4
304.8 mm	12.000	12.063	11.969	0.750	0.781	0.719	0.469	0.500	0.438	11.781	0.109	0.156	12.17
	304.8	306.4	304.0	19.1	19.8	18.3	11.9	12.7	11.1	299.2	2.8	4.0	309.1
318.5 mm	12.539	12.602	12.508	0.750	0.781	0.719	0.469	0.500	0.438	12.321	0.109	0.156	12.71
	318.5	320.1	317.7	19.1	19.8	18.3	11.9	12.7	11.1	313.0	2.8	4.0	322.8
12 300	12.750	12.813	12.719	0.750	0.781	0.719	0.469	0.500	0.438	12.531	0.109	0.156	12.92
	323.9	325.5	323.1	19.1	19.8	18.3	11.9	12.7	11.1	318.3	2.8	4.0	328.2

STEEL PIPE AND ALL MATERIALS GROOVED WITH "ES" ROLLS

Pipe Size		Dimensions – inches/millimeters											
Nominal Size inches/ mm	Actual Outside Diameter inches/ mm	Pipe Outside Diameter		Gasket Seat "A"		Groove Width "B"		Groove Diameter "C"		Groove Depth "D" (ref.)	Min. Allow. Wall Thick. "T"	Max. Allow. Flare Dia. "F"	
		Max.	Min.	Max.	Min.	Max.	Min.	Max.	Min.				
2	2.375	2.399	2.351	0.572	0.552	0.265	0.250	2.250	2.235	0.063	0.154	2.480	
50	60.3	60.9	59.7	14.5	14.0	6.7	6.4	57.2	56.8	1.6	3.9	63.0	
2½	2.875	2.904	2.846	0.572	0.552	0.265	0.250	2.720	2.702	0.078	0.203	2.980	
65	73.0	73.8	72.3	14.5	14.0	6.7	6.4	69.1	68.6	2.0	5.2	75.7	
3	3.500	3.535	3.469	0.572	0.552	0.265	0.250	3.344	3.326	0.083	0.216	3.600	
80	88.9	89.8	88.1	14.5	14.0	6.7	6.4	84.9	84.5	2.1	5.5	91.4	
4	4.500	4.545	4.469	0.610	0.590	0.320	0.300	4.334	4.314	0.083	0.237	4.600	
100	114.3	115.4	113.5	15.5	15.0	8.1	7.6	110.1	109.6	2.1	6.0	116.8	
6	6.625	6.688	6.594	0.610	0.590	0.320	0.300	6.455	6.433	0.085	0.280	6.730	
150	168.3	169.9	167.5	15.5	15.0	8.1	7.6	164.0	163.4	2.2	7.1	170.9	
8	8.625	8.688	8.594	0.719	0.699	0.410	0.390	8.441	8.416	0.092	0.322	8.800	
200	219.1	220.7	218.3	18.3	17.8	10.4	9.9	214.4	213.8	2.3	8.2	223.5	
10	10.750	10.813	10.719	0.719	0.699	0.410	0.390	10.562	10.535	0.094	0.365	10.920	
250	273.0	274.7	272.3	18.3	17.8	10.4	9.9	268.3	267.6	2.4	9.3	277.4	
12	12.750	12.813	12.719	0.719	0.699	0.410	0.390	12.531	12.501	0.109	0.375	12.920	
300	323.9	325.5	323.1	18.3	17.8	10.4	9.9	318.3	317.5	2.8	9.5	328.2	

COPPER TUBING TO CTS US STANDARD – ASTM B-88 AND ASTM B-306

Nominal inches/ Actual mm		Dimensions – inches/millimeters										
		Copper Tubing Outside Diameter †		Gasket Seat "A"		Groove Width "B"		Groove Diameter "C"		Groove Depth "D" (ref.)	Min. Allow. Wall Thick. "T"	Max. Allow. Flare Dia. "F"
		Max.	Min.	Basic	Max.	Min.	Max.	Min.	Max.			
2	2.127	2.123	0.610	0.640	0.580	0.330	0.300	2.029	2.009	0.048	DWV *	2,220
5/4	54.0	53.9	15.5	16.3	14.7	8.4	7.6	51.5	51.0	1.2		56.4
2½	2.627	2.623	0.610	0.640	0.580	0.330	0.300	2.525	2.505	0.050		2,720
6/7	66.7	66.6	15.5	16.3	14.7	8.4	7.6	64.1	63.6	1.2		69.1
3	3.127	3.123	0.610	0.640	0.580	0.330	0.300	3.025	3.005	0.050	DWV *	3,220
7/4	79.4	79.3	15.5	16.3	14.7	8.4	7.6	76.8	76.3	1.2		81.8
4	4.127	4.123	0.610	0.640	0.580	0.330	0.300	4.019	3.999	0.053	DWV *	4,220
10/4.8	104.8	104.7	15.5	16.3	14.7	8.4	7.6	102.1	101.6	1.4		107.2
5	5.127	5.123	0.610	0.640	0.580	0.330	0.300	4.999	4.979	0.063	DWV *	5,220
13/0.2	130.2	130.1	15.5	16.3	14.7	8.4	7.6	127.0	126.5	1.6		132.6
6	6.127	6.123	0.610	0.640	0.580	0.330	0.300	5.999	5.979	0.063	DWV *	6,220
155/6	155.6	155.5	15.5	16.3	14.7	8.4	7.6	152.3	151.9	1.6		158.0
8	8.127	8.121	0.610	0.640	0.580	0.330	0.300	7.959	7.939	0.083	DWV *	8,220
206/4	206.4	206.3	15.5	16.3	14.7	8.4	7.6	202.2	201.7	2.1		208.8

† The outside diameter of roll grooved copper tubing cannot vary from the tolerance listed. The maximum allowable tolerance from square cut ends is 0.030 inch/0.8 mm for 2 – 3 inch/54.0 – 79.4 mm sizes and 0.045 inch/1.1 mm for 4 – 6 inch/104.8 – 155.6 mm sizes; this is measured from the true square line.

* ASTM B-306 drain-waste and vent (DWV) is the minimum wall thickness of copper tubing that can be roll grooved.

COPPER TUBING TO EUROPEAN STANDARD – EN 1057

Actual Size † mm		Dimensions – inches/millimeters										
		Actual Outside Diameter *		Gasket Seat "A"		Groove Width "B"		Groove Diameter "C"		Groove Depth "D" (ref.)	Max. Allow. Flare Dia. "F"	
		Max.	Min.	Basic	Max.	Min.	Max.	Min.	Max.			Min.
54	54.07 2.129	53.93 2.123	15.87 0.625	16.64 0.655	15.11 0.595	8.38 0.330	7.62 0.300	51.51 2.028	51.00 2.008	1.25 0.049	56.38 2.220	
64	64.07 2.522	63.93 2.517	15.87 0.625	16.64 0.655	15.11 0.595	8.38 0.330	7.62 0.300	61.47 2.420	60.96 2.400	1.27 0.050	66.41 2.615	
66.7	66.77 2.629	66.63 2.623	15.87 0.625	16.64 0.655	15.11 0.595	8.38 0.330	7.62 0.300	64.14 .525	63.63 2.505	1.27 0.050	69.09 2.720	
76.1	76.17 2.999	76.03 2.993	15.87 0.625	16.64 0.655	15.11 0.595	8.38 0.330	7.62 0.300	73.41 2.890	72.90 2.870	1.35 0.053	78.61 3.095	
88.9	88.97 3.496	88.83 3.497	15.87 0.625	16.64 0.655	15.11 0.595	8.38 0.330	7.62 0.300	85.70 3.374	85.19 3.354	1.60 0.063	91.63 3.607	
108	108.07 4.255	107.93 4.249	15.87 0.625	16.64 0.655	15.11 0.595	8.38 0.330	7.62 0.300	104.80 4.126	104.29 4.106	1.60 0.063	110.54 4.352	
133	133.20 5.244	132.80 5.228	15.87 0.625	16.64 0.655	15.11 0.595	8.38 0.330	7.62 0.300	129.29 5.090	128.78 5.070	1.85 0.073	135.79 5.346	
159	159.20 6.280	158.80 6.252	15.87 0.625	16.64 0.655	15.11 0.595	8.38 0.330	7.62 0.300	155.30 6.114	154.79 6.094	1.85 0.073	161.80 6.370	

† European Standard Copper Tubing: EN 1057 drawn copper tubing size

* The outside diameter of roll grooved copper tubing cannot vary from the tolerance listed. The maximum allowable tolerance from square cut ends is 0.8 mm/0.030 inch for 54 – 88.9 mm sizes and 1.1 mm/0.045 inch for 108 – 159 mm sizes; this is measured from the true square line.

COPPER TUBING TO AUSTRALIAN STANDARD – AS 1432

Nominal Size † mm	Dimensions – inches/millimeters												Max. Allow. Flare Dia. "F"
	Actual Outside Diameter *		Gasket Seat "A"		Groove Width "B"		Groove Diameter "C"		Groove Depth "D" (ref.)	Max. Allow. Flare Dia. "F"			
	Max.	Min.	Basic	Max.	Min.	Max.	Min.	Max.			Min.		
DN 50	50.80 2.000	50.67 1.995	15.87 0.625	16.64 0.655	15.11 0.595	8.38 0.330	7.62 0.300	48.21 1.898	47.70 1.878	1.25 0.049	53.06 2.089		
DN 65	63.50 2.500	63.35 2.494	15.87 0.625	16.64 0.655	15.11 0.595	8.38 0.330	7.62 0.300	60.88 2.397	60.38 2.377	1.27 0.050	65.83 2.592		
DN 80	76.20 3.000	76.02 2.993	15.87 0.625	16.64 0.655	15.11 0.595	8.38 0.330	7.62 0.300	73.56 2.896	73.05 2.876	1.27 0.050	78.51 3.091		
DN 100	101.60 4.000	101.35 3.990	15.87 0.625	16.64 0.655	15.11 0.595	8.38 0.330	7.62 0.300	98.78 3.889	98.27 3.869	1.35 0.053	103.88 4.090		
DN 125	127.00 5.000	126.75 4.990	15.87 0.625	16.64 0.655	15.11 0.595	8.38 0.330	7.62 0.300	123.67 4.869	123.16 4.849	1.60 0.063	128.77 5.070		
DN 150	152.40 6.000	152.10 5.988	15.87 0.625	16.64 0.655	15.11 0.595	8.38 0.330	7.62 0.300	149.05 5.868	148.54 5.848	1.60 0.063	154.66 6.089		

† Nominal AS 1432 drawn copper tubing size

* The outside diameter of roll grooved copper tubing cannot vary from the tolerance listed. The maximum allowable tolerance from square cut ends is 0.8 mm/0.030 inch for DN 50 – 80 mm sizes and 1.1 mm/0.045 inch for DN 100 – 150 mm sizes; this is measured from the true square line.

This page intentionally blank

EC DECLARATION OF INCORPORATION

In Accordance with the Machinery Directive 2006/42/EC

Victaulic Company, headquartered at 4901 Kesslersville Road, Easton, PA 18040, USA, hereby declares that the machinery listed below complies with the essential safety requirements of the Machinery Directive, 2006/42/EC.

Product Model:	VE-272 SFS
Serial No. :	Refer to Machinery Nameplate
Product Description:	Portable Pipe Roll Grooving Tool
Conformity Assessment:	2006/42/EC, Annex I
Technical Documentation:	The relevant technical documentation prepared in accordance with Annex VII (B) of the Machinery Directive 2006/42/EC, will be made available upon request to the governing authorities.
Compatible Power Drives:	When installed with any of the following power drive units, each having an appropriate EC Declaration of Conformity in accordance with Annex II (A) of the Directive 2006/42/EC, the VE-272 SFS may be commissioned for its full intended purpose:

Victaulic VPD752	Victaulic VPD753	Berkley Tool BT-5020	Ridgid* 300
---------------------	---------------------	-------------------------	-------------

Authorized Representative: Victaulic Company
c/o Victaulic Europe BVBA
Prijkelstraat 36
9810, Nazareth
Belgium

Signed for and on behalf of Victaulic Company,



Mr. Len R. Swantek
Director – Global Regulatory Compliance
Machinery Manufacturer Representative

Place of Issue: Easton, Pennsylvania, USA

Date of Issue: April 11, 2016

MD_DoI_RGT_001_041116_en

*RIDGID IS A REGISTERED TRADEMARK OF RIDGE TOOL COMPANY.
VICTAULIC IS A REGISTERED TRADEMARK OF VICTAULIC COMPANY. ©2013 VICTAULIC COMPANY. ALL RIGHTS RESERVED.



VE272SFS Pipe/Tubing Roll Grooving Tool

UPDATED 04/2016

TM-VE272SFS 3776 REV C RM00272SFS

VICTAULIC IS A REGISTERED TRADEMARK OF VICTAULIC COMPANY.

© 2016 VICTAULIC COMPANY. ALL RIGHTS RESERVED.



VE270FSD and VE271FSD

PIPE ROLL GROOVING TOOLS

**WARNING****WARNING**

Failure to follow instructions and warnings could result in serious personal injury, property damage, and/or product damage.

- Before operating or servicing any roll grooving tools, read all instructions in this manual and all warning labels on the tool.
- Wear safety glasses, hardhat, foot protection, and hearing protection while working around this tool.
- Save this operating and maintenance manual.

If you need additional copies of any literature, or if you have questions concerning the safe and proper operation of this tool, contact Victaulic, P.O. Box 31, Easton, PA 18044-0031, Phone: 1-800-PICK VIC, E-Mail: pickvic@victaulic.com.

INDEX

Hazard Identification	2	Maintenance	29
Operator Safety Instructions	2	Lubrication	29
Introduction	4	Checking and Filling Hydraulic Hand Pump Hydraulic Fluid	30
Receiving the Tool	4	Air Bleeding	31
Tool Nomenclature	5	Recommended Lubricants	32
Tool Setup	6	Parts Ordering Information	32
VE270FSD Overall Dimensions and Mounting Hole Locations	7	Accessories	33
Power Requirements	7	Troubleshooting	34
Extension Cord Requirements	7	Tool Rating and Roll Selection	36
Preparing Pipe for Grooving	8	Original Groove System and “ES” Rolls for Steel and Schedule 40 Stainless Steel Pipe - Color-Coded Black	36
Pipe Length Requirements	8	Original Groove System Rolls for Aluminum and PVC Plastic Pipe - Color-Coded Yellow Zinc	37
Checking and Adjusting the Tool		Original Groove System Rolls for Schedule 5S and 10S Stainless Steel Pipe - Color-Coded Silver	38
Prior to Grooving	9	Rolls for CTS US Standard - ASTM B-88 Hard-Drawn Copper Tubing and DWV Per ASTM B-306 – Color-Coded Copper	38
Grooving Rolls	9	Explanation of Critical Roll Groove Dimensions	39
Keyless Arbors and Universal Lower Rolls	10	Roll Groove Specifications	40
Groove Diameter Stop Adjustment	11	Original Groove System for Steel and Stainless Steel Pipe	40
Adjusting the Roll Guards	13	Original Groove System for Steel Pipe and All Materials Grooved with “ES” Rolls	43
Pipe Stabilizer Adjustment	15	CTS US Standard - ASTM B-88 Hard-Drawn Copper Tubing and DWV Per ASTM B-306	44
Grooving Short Pipe Lengths	17	European Standard – EN 1057 R250 (Half-Hard) Copper Tubing	45
Grooving Long Pipe Lengths	20	Australian Standard – AS 1432 Tables A, B, and D Copper Tubing	46
Roll Changing	23		
Lower Roll Removal for ¾-inch/26.9-mm and 1 – 1 ½-inch/33.7 – 48.3-mm Sizes	23		
Lower Roll Removal for 2-inch/60.3-mm and Larger Sizes	23		
Upper Roll Removal - All Sizes	25		
Arbor Removal for 2-inch/60.3-mm and Larger Sizes	25		
Upper Roll Installation - All Sizes	26		
Lower Roll Assembly Installation for ¾-inch/26.9-mm and 1 – 1 ½-inch/ 33.7 – 48.3-mm Sizes	27		
Arbor Installation Procedure for 2-inch/60.3-mm and Larger Sizes	27		
Lower Roll Installation for 2-inch/60.3-mm and Larger Sizes	28		

HAZARD IDENTIFICATION

Definitions for identifying the various hazard levels are provided below.



This safety alert symbol indicates important safety messages. When you see this symbol, be alert to the possibility of personal injury.

Carefully read and fully understand the message that follows.



DANGER

- The use of the word “DANGER” identifies an immediate hazard with a likelihood of death or serious personal injury if instructions, including recommended precautions, are not followed.



WARNING

- The use of the word “WARNING” identifies the presence of hazards or unsafe practices that could result in death or serious personal injury if instructions, including recommended precautions, are not followed.



CAUTION

- The use of the word “CAUTION” identifies possible hazards or unsafe practices that could result in personal injury and product or property damage if instructions, including recommended precautions, are not followed.

NOTICE

- The use of the word “NOTICE” identifies special instructions that are important but not related to hazards.

OPERATOR SAFETY INSTRUCTIONS

The VE270FSD is designed only for roll grooving pipe. Use of this tool requires dexterity and mechanical skills, as well as sound safety habits. Although this tool is manufactured for safe, dependable operation, it is impossible to anticipate all combinations of circumstances that could result in an accident. The following instructions are recommended for safe operation of this tool. The operator is cautioned to always practice “safety first” during each phase of use, including setup and maintenance. It is the responsibility of the owner, lessee, or user of this tool to ensure that all operators read this manual and fully understand the operation of this tool.

Read this manual before operating or servicing this tool. Become familiar with the tool's operations, applications, and limitations. Be particularly aware of its specific hazards. Store this manual in a clean area where it is always readily available. Additional copies of this manual are available upon request through Victaulic.

1. The VE270FSD tool is designed ONLY for roll grooving pipe sizes, materials, and wall thicknesses listed in the applicable “Tool Rating and Roll Selection” section.
2. Avoid using the tool in dangerous environments. Do not expose the tool to rain, and do not use the tool in damp or wet locations. Do not use the tool on sloped or uneven surfaces. Keep the work area well lit. Allow sufficient space to operate the tool properly.
3. Ground the motor/drive to protect the operator from electric shock. The motor/drive must be connected to an internally-grounded electrical source.
4. Prevent back injury. Always practice safe lifting techniques.

5. Inspect the equipment. Before using the tool, check all moveable parts for any obstructions. Make sure guards and tool components are installed and adjusted properly.
6. Prevent accidental startups. Disconnect the tool from the electrical source when the tool is not in use.
7. Wear proper apparel. Do not wear loose clothing, jewelry, or anything that can become entangled in moving parts.
8. Wear protective items when working with tools. Always wear safety glasses, hardhat, foot protection, and hearing protection.
9. Stay alert. Do not operate the tool if you are drowsy from medication or fatigue. Avoid horseplay around the equipment.
10. Keep visitors away from the immediate work area. All visitors should be kept a safe distance from the equipment at all times.
11. Keep work areas clean. Keep the work area around the tool clear of any obstructions that could limit the movement of the operator. Clean up any oil or other spills.
12. Secure the work, tool, and accessories. Make sure the tool is stable. Refer to the applicable "Tool Setup" section.
13. Support the work. Support long pipe lengths with a pipe stand that is secured to the floor or the ground.
14. Operate the tool only with a safety foot switch. The motor/drive must be operated with a safety foot switch that is located for easy operator access. Never reach across moving parts. If the tool does not contain a safety foot switch, contact Victaulic.
15. Keep hands and tools away from grooving rolls and stabilizer roller during the grooving operation. Grooving rolls can crush or cut fingers and hands.
16. Do not reach inside the pipe ends during tool operation. Pipe edges can be sharp and can snag gloves, hands, and shirt sleeves. Fingers and hands can be crushed between the pipe and lower roll.
17. Do not over-reach. Maintain proper footing and balance at all times. Make sure the safety foot switch is easily accessible for the operator.
18. Do not force the tool. Do not force the tool or accessories to perform any functions beyond their capabilities. Do not overload the tool.
19. Do not abuse the foot switch cord. Keep the cord away from heat, oil, and sharp objects.
20. Always disconnect the tool from the electrical source before servicing or adjusting the tool. Only authorized personnel should attempt to perform maintenance on the tool.
21. Maintain tools with care. Keep tools clean at all times to ensure proper and safe performance. Follow the instructions for lubricating tool components.
22. Use only Victaulic replacement parts and accessories. Use of any other parts may result in a voided warranty, improper operation, and hazardous situations.
23. Do not remove any labels from the tool. Replace any damaged or worn labels.

INTRODUCTION**NOTICE**

- **Drawings and/or pictures in this manual may be exaggerated for clarity.**
- **The tool, along with this operating and maintenance instructions manual, contains trademarks, copyrights, and/or patented features that are the exclusive property of Victaulic Company.**

VE270FSD Roll Grooving Tools are semi-automated, hydraulic-feed tools for roll grooving pipe to receive Victaulic grooved pipe products. The standard VE270FSD tool is supplied with rolls for grooving 2 - 12-inch/60.3 - 323.9-mm carbon steel pipe. VE270FSD rolls are marked with the size and part number, and they are color coded to identify the pipe material. For roll grooving to other specifications and materials, refer to the applicable “Tool Rating and Roll Selection” section. Grooving rolls for other specifications, sizes, and materials must be purchased separately.

**CAUTION**

- **These tools must be used ONLY for roll grooving pipe designated in the applicable “Tool Rating and Roll Selection” section of this manual.**

Failure to follow this instruction could overload the tool, resulting in reduced tool life and/or damage to the tool.

RECEIVING THE TOOL

VE270FSD tools are palletized individually and enclosed in a cardboard sleeve, which is designed for use in re-shipping the tool back to Victaulic upon completion of the rental contract, when applicable. Optional roll sets and pipe stabilizer/mounting hardware are shipped in a separate container.

Upon receipt of the tool, make sure all necessary parts are included. If any parts are missing, contact Victaulic.

VE270FSD CONTAINER CONTENTS

Qty.	Description
1	VE270FSD Tool Head with Mounting Table and Motor/Drive, Four Legs, Safety Foot Switch with Cord, and Hydraulic Hand Pump/Pump Support Assembly
1	Lower Roll for 2 - 3 1/2-inch/60.3 - 101.6-mm Carbon Steel Pipe
1	Lower Roll for 4 - 6-inch/114.3 - 168.3-mm Carbon Steel Pipe.
1	Upper Roll for 2 - 6-inch/60.3 - 168.3-mm Carbon Steel Pipe.
1	Roll Set for 8 - 12-inch/219.1 - 323.9-mm Carbon Steel Pipe Mounted on the Tool (Unless Ordered Otherwise)
2	TM-VE270FSD Operating and Maintenance Instructions Manual
2	RP-270FSD Repair Parts List
1	Guard Setting Pad
1	Lower Roll Removal Wedge
1	Pipe Diameter Tape
1	Can of Mechanical Assembly Spray
1	Roll Storage Bag

TOOL NOMENCLATURE

NOTICE

- Drawings and/or pictures in this manual may be exaggerated for clarity.
- The tool, along with this operating and maintenance instructions manual, contains trademarks, copyrights, and/or patented features that are the exclusive property of Victaulic.

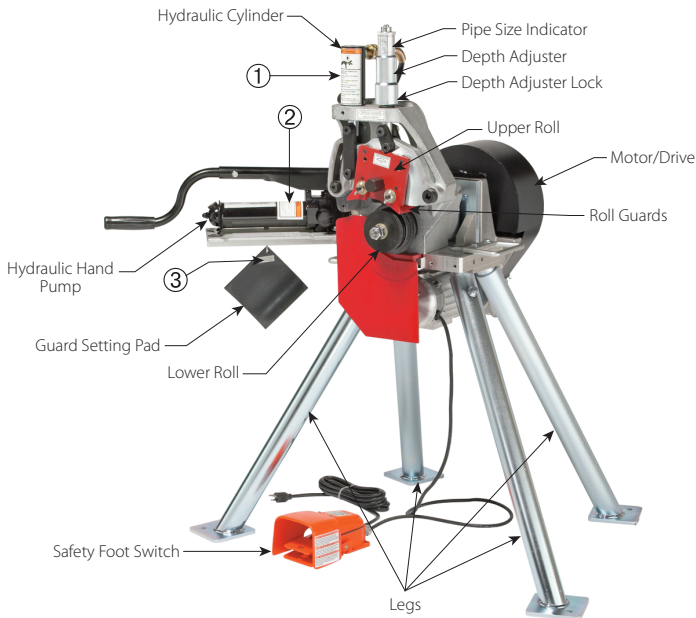

①

WARNING

Grooving rolls can crush or cut fingers and hands.

- Always disconnect the tool from the power source before making any tool adjustments.
- Make sure the guard is adjusted properly before grooving pipe.
- Loading/unloading pipe will place your hands close to the grooving rolls. Keep hands away from the grooving rolls and the roller on the pipe stabilizer during operation.
- Never reach inside the pipe ends or across the tool or pipe during operation.
- Never groove pipe that is shorter than the recommended lengths listed in the operating and maintenance manual.
- Never wear loose clothing, loose gloves, or anything that can become entangled in moving parts.

234 Rev. D R07376LB

②

WARNING

Failure to follow instructions and warnings could result in serious personal injury, property damage, and/or product damage.

- Before operating or servicing any pipe preparation tools, read all instructions in the Operating and Maintenance Instructions Manual and all labels on the tool.
- Wear safety glasses, hardhat, foot protection, and hearing protection when working around tools.

If you need additional copies of any literature, or if you have questions concerning the safe and proper operation of any pipe preparation tools, contact Victaulic, P.O. Box 31, Easton, PA 18044-0031, Phone 1-800-792-6126, Ext. 5, E-Mail: prodsvic@victaulic.com.

997 Rev. D R01172AB

③

ALWAYS KEEP THIS PAD WITH THE TOOL. USE IT TO SET THE GUARDS IN ACCORDANCE WITH THE TOOL OPERATION AND MAINTENANCE MANUAL.

496B Rev. D R068272LAB

TOOL SETUP**⚠ WARNING**

- **DO NOT connect the tool to the electrical source until instructed otherwise.**
- **The tool MUST be leveled and anchored securely on a concrete floor or base.**

Failure to follow these instructions could result in serious personal injury.

1. Remove all components from the packaging, and make sure all necessary items are included. Refer to the "Receiving the Tool" section.



2. The VE270FSD Roll Grooving Tool must be located on a level concrete floor or base. After an appropriate location is chosen, the tool must be leveled front to back and anchored securely. **NOTE:** The tool's legs are adjustable to aid in leveling the tool. A non-level tool can severely affect grooving operation. When checking tool level, place the level on top of the hydraulic cylinder, as shown above.

3. Select a location for the tool and pipe stand by taking into consideration the following factors:
 - 3a. The required power supply (refer to the "Power Requirements" section)
 - 3b. Ambient temperature requirements of 20° F to 104° F/-21°C to 26° C
 - 3c. A level concrete floor or base for the tool and pipe stand
 - 3d. Adequate space to handle pipe lengths
 - 3e. Adequate clearance around the tool and stabilizer assembly (if equipped) for adjustment and maintenance (refer to drawings on following page)

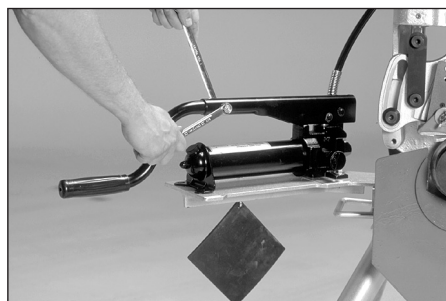

4. Insert the hand pump handle into the lever arm of the hydraulic hand pump. Position the hand pump handle with the handle grip facing down. Lock the handle in this position with the set screw or nut/bolt provided.



5. Connect the hydraulic line from the hydraulic hand pump to the hydraulic cylinder using the connectors provided.

VE270FSD tool setup is complete.

VE270FSD OVERALL DIMENSIONS AND MOUNTING HOLE LOCATIONS

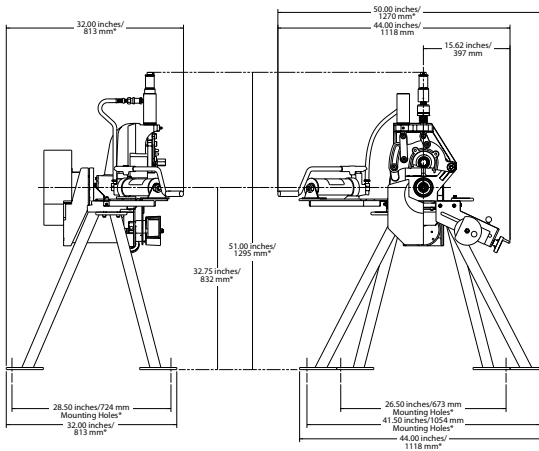

POWER REQUIREMENTS

DANGER

- To reduce the risk of electric shock, check the electrical source for proper grounding.
- Before performing any maintenance on the tool, disconnect the tool from the electrical source.

Failure to follow these instructions could result in death or serious personal injury.

The VE270FSD is equipped with a 120 VAC 50/60-Hz motor. Maximum current draw is 15 amps. The VE271FSD is equipped with a 220 VAC 50/60-Hz motor. Maximum current draw is 8 amps. In addition, tools are equipped with the corresponding grounded plug.



Power must be supplied to the motor/drive through a safety foot switch to ensure safe operation. Make sure the motor/drive is grounded properly in accordance with Article 250 of the National Electrical Code.

If an extension cord is required, refer to the “Extension Cord Requirements” section for cord sizes.

EXTENSION CORD REQUIREMENTS

When pre-wired outlets are not available and an extension cord must be used, it is important to use the proper cord size (i.e. Conductor Size American Wire Gauge). Cord size selection is based upon tool rating (amps) and cord length (feet). Cord sizes (gauges) thinner than required will cause significant voltage drop at the motor/drive while the tool is operating. Voltage drops may cause damage to the motor/drive and can result in improper tool operation. **NOTE:** It is acceptable to use a heavier cord size (gauge) than what is required.

The required cord sizes (gauges) for cord lengths, up to and including 100 feet/30 m, are listed in the table below. Use of extension cords longer than 100 feet/30 m must be avoided.

Motor/Drive Rating	Cord Lengths		
Volts (Amps)	25 feet/ 8 m	50 feet/ 15 m	100 feet/ 30 m
115 15	12 gauge	12 gauge	10 gauge
220 8	16 gauge	16 gauge	14 gauge

PREPARING PIPE FOR GROOVING

For proper tool operation and production of grooves that are within Victaulic specifications, the following pipe preparation steps must be followed.

Victaulic recommends square-cut pipe for use with grooved-end pipe products. Square-cut pipe **MUST** be used with Victaulic FlushSeal® and EndSeal® gaskets. For 12-inch/323.9-mm and smaller pipe sizes, beveled-end pipe may be used with Victaulic standard and Vic-Flange gaskets, provided that the wall thickness is standard wall (ANSI B36.10) or less and that the bevel meets ANSI B16.25 (37½°) or ASTM A-53 (30°). **NOTE:** Roll grooving beveled-end pipe may result in unacceptable pipe flare.

1. For 12-inch/323.9-mm and smaller pipe sizes, raised internal and external weld beads and seams must be ground flush with the pipe surface 2 inches/50 mm back from the pipe ends.
2. All coarse scale, dirt, and other foreign material must be removed from the interior and exterior surfaces of the pipe ends.



CAUTION

- **For maximum grooving roll life, remove foreign material and loose rust from the interior and exterior surfaces of the pipe ends. Rust is an abrasive material that will wear the surface of grooving rolls.**

Foreign material may interfere with or damage grooving rolls, resulting in distorted grooves and grooves that are out of Victaulic specifications.

PIPE LENGTH REQUIREMENTS

VE270FSD tools are capable of grooving short pipe lengths without the use of a pipe stand. Table 1 identifies the minimum pipe lengths that can be grooved safely by using Victaulic Grooving Tools. In addition, this table identifies the maximum pipe lengths that can be grooved without the use of a pipe stand. Refer to the “Grooving Short Pipe Lengths” section for instructions on how to groove short pipe lengths. **NOTE:** Grooved pipe nipples, shorter than those listed in Table 1, are available from Victaulic.

Pipe lengths, longer than those listed in Table 1 (and up to 20 feet/6 meters), must be supported with a pipe stand. Pipe lengths, from 20 feet/6 meters up to double-random lengths (approximately 40 feet/12 meters), must be supported with two pipe stands. Refer to the “Long Pipe Lengths” section for instructions on how to groove long pipe lengths.

If pipe is required that is shorter than the minimum length listed in Table 1, shorten the next-to-last piece so that the last piece is as long (or longer) than the minimum length specified.

EXAMPLE: A 20-foot, 4-inch/6.2-m length of 10-inch diameter steel pipe is required to finish a section, and only 20-foot/6.1-m lengths are available. Instead of roll grooving a 20-foot/6.1-m length of steel pipe and a 4-inch/102-mm length of steel pipe, follow these steps:

1. Refer to Table 1, and note that for 10-inch diameter steel pipe, the minimum length that should be roll grooved is 10 inches/255 mm.
2. Roll groove a 19-foot, 6-inch/5.9-m length of pipe and a 10-inch/255-mm length of pipe. Refer to the “Long Pipe Lengths” section.

TABLE 1- PIPE LENGTHS SUITABLE FOR GROOVING

Pipe Size		Length – inches/mm	
Nominal Pipe Size inches or mm	Actual Outside Diameter inches/mm	Minimum	Maximum
¾ 20	1.050 26.9	8 203.2	36 914.4
1 25	1.315 33.7	8 203.2	36 914.4
1¼ 32	1.660 42.4	8 203.2	36 914.4
1½ 40	1.900 48.3	8 203.2	36 914.4
2 50	2.375 60.3	8 203.2	36 914.4
2½ 65	2.875 73.0	8 203.2	36 914.4
3 80	3.500 88.9	8 203.2	36 914.4
3½ 90	4.000 101.6	8 203.2	36 914.4
108.0 mm	4.250 108.0	8 205	36 915
4	4.500 114.3	8 205	36 915
4½	5.000 127.0	8 205	32 815
133.0 mm	5.250 133.0	8 205	32 815
139.7 mm	5.500 139.7	8 205	32 815
5	5.563 141.3	8 205	32 815

Pipe Size		Length – inches/mm	
Nominal Pipe Size inches or mm	Actual Outside Diameter inches/mm	Minimum	Maximum
152.4 mm	6.000 152.4	10 255	30 765
159.0 mm	6.250 159.0	10 255	30 765
165.1 mm	6.500 165.1	10 255	30 765
6	6.625 168.3	10 255	28 715
203.2 mm	8.000 203.2	10 255	24 610
216.3 mm	8.516 216.3	10 255	24 610
8	8.625 219.1	10 255	24 610
254.0 mm	10.000 254.0	10 255	20 510
267.4 mm	10.528 267.4	10 255	20 510
10	10.750 273.0	10 255	20 510
304.8 mm	12.000 304.8	12 305	18 460
318.5 mm	12.539 318.5	12 305	18 460
12	12.750 323.9	12 305	18 460

CHECKING AND ADJUSTING THE TOOL PRIOR TO GROOVING

Every Victaulic roll grooving tool is checked, adjusted, and tested at the factory prior to shipment. However, before attempting to operate the tool, the following checks and adjustments should be made to ensure proper tool operation.

WARNING

- Always disconnect the turn off the main power supply to the tool before making any tool adjustments.

Failure to follow this instruction could result in serious personal injury.

GROOVING ROLLS

Make sure the proper roll set is installed on the tool for the pipe/tubing size and material that will be grooved. Roll sets are marked with the pipe size, part number, and they are color coded for the pipe material. Refer to the applicable “Tool Rating and Roll Selection” section. If the proper rolls are not installed on the tool, refer to the “Roll Changing” section.

CAUTION

- Make sure roll retaining bolts and nuts are tight.

Loose roll retaining bolts and nuts could cause damage to the tool and rolls.

KEYLESS ARBORS AND UNIVERSAL LOWER ROLLS

Victaulic has introduced an improved “keyless” method for transmitting grooving power between the arbor and lower roll. This “keyless” design applies to the lower rolls and arbor only. All existing upper roll sets are compatible with all lower roll types, as described in this section. The possibility of losing or shearing Woodruff keys is eliminated with this “keyless” method.

The patented “keyless” lower grooving rolls still allow hands-free grooving for short pipe lengths listed in the “Pipe Length Requirements” section of this manual.

1. It is important to determine what type of arbor is available for the tool.

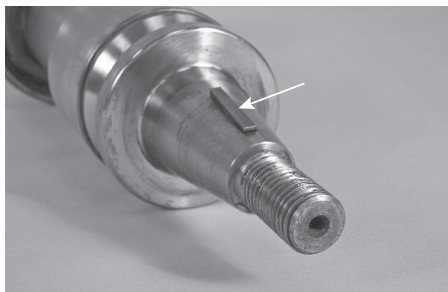

The keyed-type arbor contains a Woodruff key and can be used with new, universal-type lower rolls and older-type lower rolls.

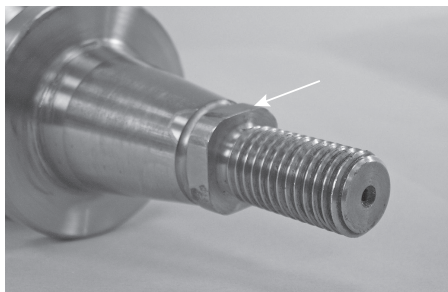

The “keyless-type” arbor contains a square drive and can be used ONLY with the new, universal-type lower rolls.

2. It is important to determine what type of lower rolls are available for the tool.

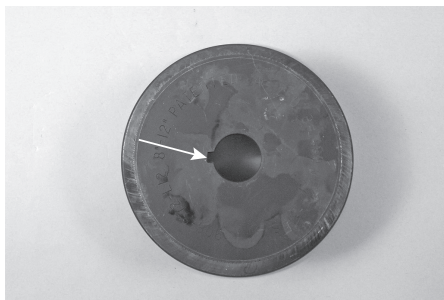

The “key-drive only” lower rolls, shown in the photo above, have a circular bore and can be used ONLY with the keyed-type arbors that contain the Woodruff key. Refer to the photo in the previous column for the keyed-type arbor.

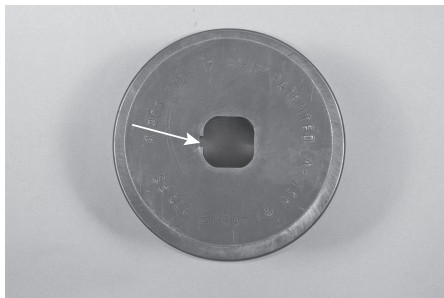

The “universal” lower rolls, shown in the photo above, have a square bore that allows for easy installation onto the “keyless” arbor. In addition, these “universal” lower rolls contain a keyway for use with keyed-type arbors.

⚠ CAUTION

- **DO NOT attempt to install a “key-drive only” lower roll onto a tool that has a “keyless” arbor.**

Failure to follow this instruction could result in damage to the arbor and lower roll.

GROOVE DIAMETER STOP ADJUSTMENT

The groove diameter stop must be adjusted for each pipe size or change in wall thickness. The groove diameter, which is identified as the “C” dimension, is listed under the “Roll Groove Specifications” section. In addition, a label is affixed to the tool, which lists the “C” dimensions.

NOTICE

- **To perform the following adjustments, Victaulic recommends the use of several short, scrap sections of pipe that are the proper material, diameter, and thickness to be grooved. Make sure the scrap sections meet the length requirements listed in Table 1.**

To achieve the proper diameter:

1. Determine the diameter and thickness of the pipe to be grooved.



2. Locate the proper diameter and thickness on the pipe size indicator. The pipe size indicator barrel can be rotated for easy viewing.



3. Unlock the depth adjuster from the depth adjuster lock.

- 3a. Align the top edge of the depth adjuster with the lowest line position of the proper size and schedule markings.
- 3b. Hold the depth adjuster to prevent it from turning.
- 3c. Turn the depth adjuster lock counterclockwise to lock the depth adjuster in this position. Back off the depth adjuster lock. Align the depth adjuster with the proper diameter and thickness indicated on the pipe size indicator. Lock the depth adjuster in position with the depth adjuster lock.

NOTICE

- **Rotating the depth adjusters while locked will cause premature thread wear of the depth adjusters and cylinder ram.**
- **The markings provide an approximate groove diameter adjustment and are not exact groove diameter settings. Variations in pipe OD and wall thickness make it impossible to calibrate the groove diameter stop exactly.**
- **Set the initial adjustment shallow (at bottom edge of mark), groove a sample piece of pipe, then make the final adjustment.**

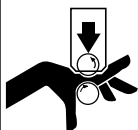

4. Insert a length of pipe over the lower roll with the pipe end against the lower-roll backstop flange.

! WARNING

Grooving rolls can crush or cut fingers and hands.

- Always turn off the main power supply to the tool before making any tool adjustments.

- Loading/unloading pipe will place your hands close to the rollers. Keep hands away from the grooving rolls and the roller on the pipe stabilizer during operation.
- Never reach inside the pipe ends or across the tool or pipe during operation.
- Always groove pipe in a **CLOCKWISE** direction.
- Never groove pipe that is shorter than the recommended lengths listed in this manual.
- Never wear loose clothing, loose gloves, or anything that can become entangled in moving parts.

5. Prepare a trial groove. Refer to the applicable "Grooving Operation" section.

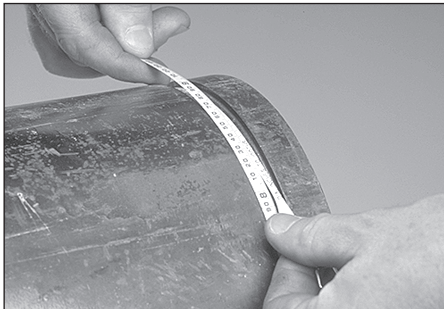

6. After a trial groove is prepared and the pipe is removed from the tool, check the groove diameter ("C" dimension) carefully. Refer to the "Roll Groove Specifications" section. A standard pipe tape, supplied with the tool, is the best method for

checking the "C" dimension. In addition, a vernier caliper or narrow-land micrometer can be used to check this dimension at two locations (90° apart) within the groove. The average reading must be within the required groove diameter specification.

! CAUTION

- The "C" dimension (groove diameter) must conform to Victaulic specifications to ensure proper joint performance.

Failure to follow this instruction could cause joint failure, resulting in personal injury and/or property damage.

7. If the groove diameter ("C" dimension) is not within Victaulic specifications, the diameter stop must be adjusted.
 - 7a. Unlock the depth adjuster from the depth adjuster lock.
 - 7b. To adjust for a smaller groove diameter, turn the depth adjuster counterclockwise (when viewed from above the tool). Turn the depth adjuster lock counterclockwise to lock the depth adjuster in this position.
 - 7c. To adjust for a larger groove diameter, turn the depth adjuster clockwise (when viewed from above the tool). Turn the depth adjuster lock counterclockwise to lock the depth adjuster in this position.

NOTE: A quarter turn either way will change the groove diameter by 0.031 inch/.79 mm or 0.125 inch/3.2 mm per full turn.

NOTICE

- Rotating the depth adjusters while locked will cause premature thread wear of the depth adjusters and cylinder ram.

8. Prepare another trial groove, and check the groove diameter ("C" dimension), as described in previous steps. Repeat these steps, as necessary, until the groove diameter is within specification.

ADJUSTING THE ROLL GUARDS

⚠ WARNING

- Always unplug the power cord before making any roll guard adjustments.

Accidental start up of tool may result in serious personal injury.

The VE270FSD guards must be adjusted every time rolls are changed or the pipe size or wall thickness is different from previous pipe grooved.

1. Make sure the proper roll set is installed on the tool for the pipe size and material to be grooved. Rolls are marked with the pipe size, part number, and they are color-coded according to the pipe material. Refer to the applicable “Tool Rating and Roll Selection” section.

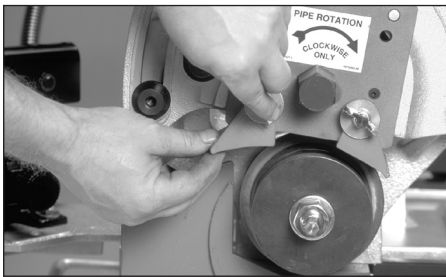

2. Loosen the wing nuts and move the adjustable guards to the full up position. Tighten the wing nuts.



3. Set the groove diameter stop to the pipe size and schedule/thickness to be grooved by backing off the depth adjuster lock and aligning the depth adjuster with the proper

pipe diameter and thickness marking. Lock the depth adjuster in position with the depth adjuster lock.

⚠ WARNING

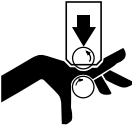

Grooving rolls can crush or cut fingers and hands.

- Loading/unloading pipe will place your hands close to the rollers. Keep hands away from the grooving rolls and the roller on the pipe stabilizer.

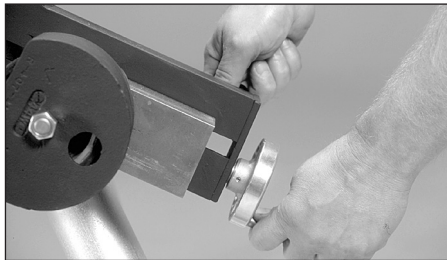

4. **If the tool is equipped with the optional pipe stabilizer:** Retract the pipe stabilizer, if necessary, to insert the pipe onto the lower roll by loosening the locking handle and retracting the stabilizer roller with the handwheel.

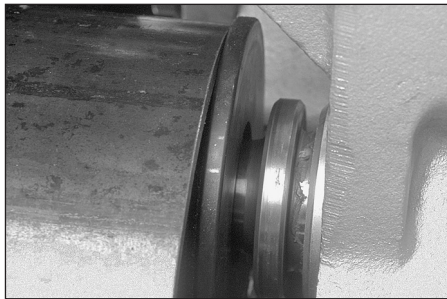

5. Insert a length of pipe that is the correct size and schedule over the lower roll. Make sure the pipe end contacts the lower-roll backstop flange. The pipe must rest directly on top of the roll and must not be skewed to one side or the other.



6. Close the valve on the hydraulic hand pump by turning it clockwise.

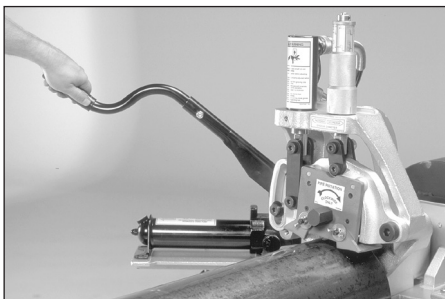
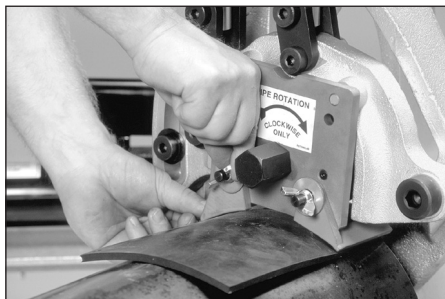

7. Pump the handle of the hydraulic hand pump to bring the upper roll down into firm contact with pipe.



9. Loosen the wing nuts and adjust each guard to conform to and lightly pinch the pad against the pipe. Tighten the wing nuts to secure each guard in position. Remove the guard setting pad.
10. Remove the guard setting pad. Store the pad on the hook provided under the hydraulic hand pump support.



8. Remove the guard setting pad from its storage hook under the hydraulic hand pump support. Hold the guard setting pad firmly down against the pipe while pushing it under the adjustable guards until it contacts the upper roll.



11. Open the valve on the hydraulic hand pump by turning it counterclockwise to allow the upper roll and arm to move to the full up position.

PIPE STABILIZER ADJUSTMENT

Applies only to tools equipped with the optional pipe stabilizer

 WARNING
<ul style="list-style-type: none"> • Always disconnect the tool from the electrical source before making any tool adjustments. • DO NOT reach over pipe while making adjustments. • DO NOT make adjustments while the tool/pipe is in operation/motion. <p>Failure to follow these instructions could result in serious personal injury.</p>

The pipe stabilizer for the VE270FSD is designed to prevent sway of short and long pipe lengths in 8 - 12-inch/219.1 - 323.9-mm sizes. The pipe stabilizer is required when grooving light-wall stainless steel pipe and 8-inch/206.4-mm copper tubing.

When the pipe stabilizer is adjusted for a selected pipe size and wall thickness, it does not require further adjustment unless pipe of a different size and wall thickness will be grooved. Pipe of the same size and wall thickness can be moved in and out of the tool without retracting the stabilizer.

1. Make sure the proper roll set is installed on the tool for the pipe size and material to be grooved. Rolls are marked with the pipe size, part number, and they are color-coded according to the pipe material. Refer to the applicable "Tool Rating and Roll Selection" section.

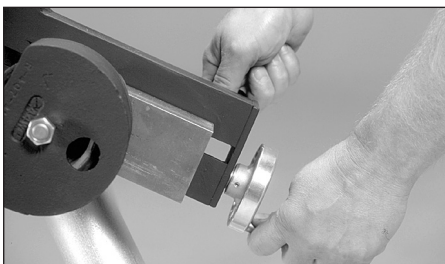

2. Loosen the stabilizer locking handle.

- 2a. Using the stabilizer handwheel, retract the stabilizer roller to clear the pipe when it is inserted onto the lower roll.

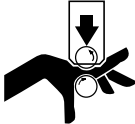
 WARNING	
	<p>Grooving rolls can crush or cut fingers and hands.</p> <ul style="list-style-type: none"> • Loading/unloading pipe will place your hands close to the rollers. Keep hands away from the grooving rolls and the roller on the pipe stabilizer.

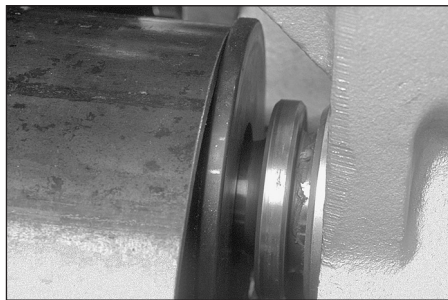

3. Insert a length of pipe that is the correct size and schedule over the lower roll. Make sure the pipe end contacts the lower-roll backstop flange. The pipe must rest directly on top of the roll and must not be skewed to one side or the other.



4. Close the valve on the hydraulic hand pump by turning it clockwise.

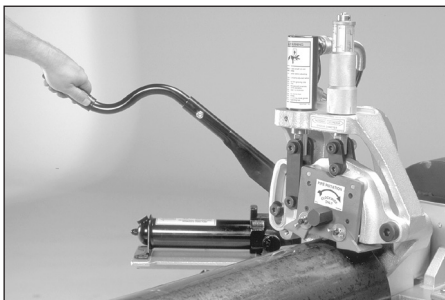

5. Pump the handle of the hydraulic hand pump to bring the upper roll down into firm contact with pipe.

CAUTION

- **DO NOT** adjust the stabilizer roller to push the pipe to the left and off center from the rolls. Increased pipe-end flare and shortened roll life will result if the pipe is pushed to the left and off center.
- **DO NOT** reach across the pipe to make pipe stabilizer adjustments.
- **DO NOT** adjust the pipe stabilizer while the pipe is in motion.
- Assembly of couplings on pipe that exceeds the maximum allowable flare dimension may prevent proper pad-to-pad assembly of coupling housings and gasket distortion/damage.

Failure to prepare pipe in accordance with all instructions may cause joint failure, resulting in personal injury and/or property damage.

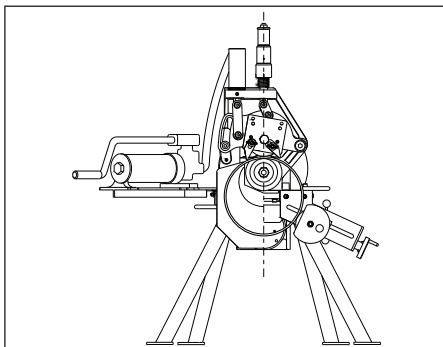

"CORRECT"

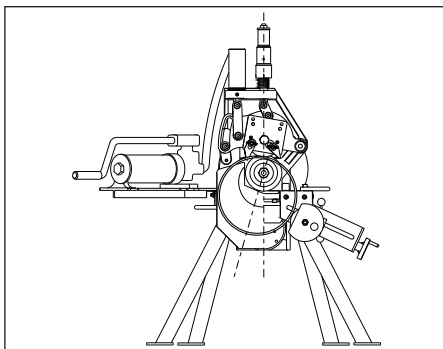

"INCORRECT"

6. Using the stabilizer handwheel, adjust the stabilizer roller inward to the correct position (shown in the drawing above). Tighten the locking handle.
7. Complete all adjustments and groove the pipe. Refer to the applicable "Grooving Operation" section. Observe the stabilizer roller while grooving. It should remain in contact with the pipe, and the pipe should rotate smoothly without swaying from side to side. If the pipe is not rotating smoothly or is swaying from side to side, discontinue grooving and adjust the stabilizer roller further. Continue the grooving operation and make further adjustments, as necessary. **DO NOT** adjust the stabilizer roller too far inward, since it will skew the pipe to the left and off center, resulting in excessive pipe-end flare.

GROOVING SHORT PIPE LENGTHS

CAUTION

- This tool must be used **ONLY** for roll grooving pipe designated in the applicable “Tool Rating and Roll Selection” section of this manual.

Failure to follow this instruction could overload the tool, resulting in reduced tool life and/or damage to the tool.

1. Before grooving, make sure all instructions in the previous sections of this manual have been followed.
2. Connect the tool to an internally-grounded electrical source.



3. Depress the safety foot switch momentarily to ensure the tool is operational. The lower roll should be rotating clockwise when viewed from the front of the tool. Remove foot from the switch.

WARNING

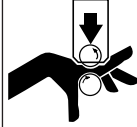

Grooving rolls can crush or cut fingers and hands.

- Always turn off the main power supply to the tool before making any tool adjustments.
- Loading/unloading pipe will place your hands close to the rollers. Keep hands away from the grooving rolls and the roller on the pipe stabilizer during operation.
- Never reach inside the pipe ends or across the tool or pipe during operation.
- Always groove pipe in a **CLOCKWISE** direction.
- Never groove pipe that is shorter than the recommended lengths listed in this manual.
- Never wear loose clothing, loose gloves, or anything that can become entangled in moving parts.



4. Open the valve on the hydraulic hand pump by turning it counterclockwise to allow the upper roll and arm to move to the full up position.



5. Insert a length of pipe that is the correct size and thickness onto the lower roll. Make sure the pipe end contacts the lower-roll backstop flange completely.



6. Close the valve on the hydraulic hand pump by turning it clockwise.

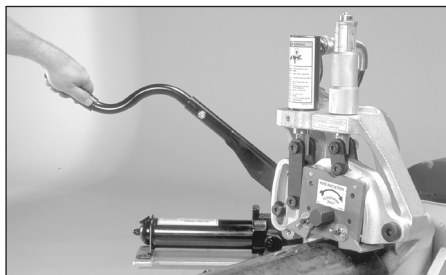

7. The operator should be positioned on the safety foot switch/hydraulic hand pump side of the tool. While manually supporting the pipe, pump the handle of the hydraulic hand pump to bring the upper roll down into firm contact with the pipe.
- 7a. Remove hands from the pipe.



8. Depress and hold down the safety foot switch. The pipe will begin to rotate clockwise when viewed from the front of the tool. As the pipe rotates, begin forming the groove by pumping the handle of the hydraulic hand pump slowly.

NOTICE

- Do not pump the handle of the hydraulic hand pump too fast. The rate should be sufficient to groove the pipe and maintain audible, moderate-to-heavy load on the motor/drive.



9. Continue the grooving process until the depth adjuster lock comes into contact with the top of the tool body. Continue pipe rotation for several revolutions to ensure groove completion.
- 9a. Release the safety foot switch, and withdraw foot from the switch.



10. Prepare to support the pipe. Open the valve on the hydraulic hand pump by turning it counterclockwise to release the pipe. Remove the pipe from the tool.
11. If no more roll grooving will be performed for a while, disconnect the tool from the electrical source.

NOTICE

- **The groove diameter must be within specification for the diameter and wall thickness of pipe. The groove diameter should be checked and adjusted, as necessary, to ensure grooves remain within specification.**

GROOVING LONG PIPE LENGTHS

CAUTION

- For long pipe lengths, make sure the pipe stand is positioned properly to minimize pipe-end flare.
- DO NOT install couplings on pipe that exceeds the maximum allowable flare.
- This tool must be used ONLY for roll grooving pipe designated in the applicable “Tool Rating and Roll Selection” section of this manual.
- Always refer to the applicable “Roll Groove Specifications” table for details.

Failure to follow these instructions could cause product failure, resulting in property damage.

When roll grooving pipe that exceeds the maximum length shown in Table 1, a roller-type pipe stand must be used. The roller-type pipe stand must be capable of handling the weight of the pipe, while allowing the pipe to rotate freely.

1. Make sure the tool is level. Refer to the “Tool Setup” section for leveling requirements.

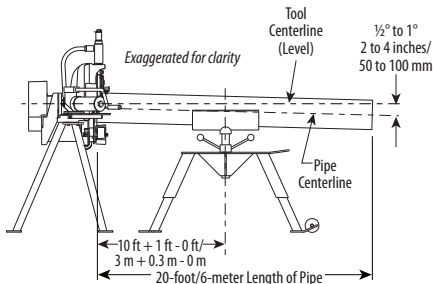

2. Place the pipe stand at a distance slightly beyond half the pipe length from the tool. Refer to the drawing above.

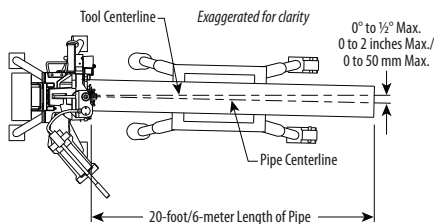

3. Position the pipe stand approximately 0 - 1/2 a degree to the left for the tracking angle. Refer to the drawing above. **NOTE:** When pipe flare is excessive, right-to-left tracking must be kept to a minimum. It may be necessary to use less than 1/2 a degree for the tracking angle.
4. If the tool is properly set up in a level position, but the back end of the pipe is higher than the end being grooved, the pipe may not track. In addition, excessive flare may occur on the pipe end. Refer to the “Tool Setup” section and the drawings above for tool setup and pipe positioning requirements.
5. Before grooving, make sure all instructions in the previous sections of this manual have been followed.
6. Connect the tool to an internally-grounded electrical source.



7. Depress the safety foot switch momentarily to ensure the tool is operational. The lower roll should be rotating clockwise when viewed from the front of the tool. Remove foot from the switch.

! WARNING

Grooving rolls can crush or cut fingers and hands.

- Always turn off the main power supply to the tool before making any tool adjustments.
- Loading/unloading pipe will place your hands close to the rollers. Keep hands away from the grooving rolls and the roller on the pipe stabilizer during operation.
- Never reach inside the pipe ends or across the tool or pipe during operation.
- Always groove pipe in a **CLOCKWISE** direction.
- Never groove pipe that is shorter than the recommended lengths listed in this manual.
- Never wear loose clothing, loose gloves, or anything that can become entangled in moving parts.

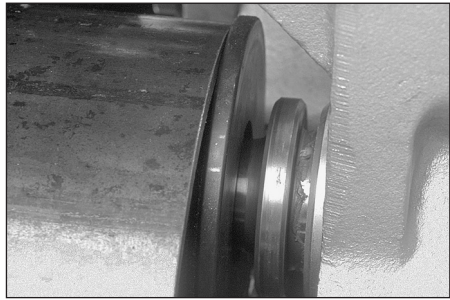

9. Insert a length of pipe that is the correct size and thickness onto the lower roll. Make sure the pipe end contacts the lower-roll backstop flange completely. Remove hands from the pipe.



10. Close the valve on the hydraulic hand pump by turning it clockwise.



8. Open the valve on the hydraulic hand pump by turning it counterclockwise to allow the upper roll and arm to move to the full up position.



11. The operator should be positioned on the safety foot switch/hydraulic hand pump side of the tool, as shown above. Pump the handle of the hydraulic hand pump to bring the upper roll down into firm contact with the pipe.
- 11a. Depress and hold down the safety foot switch. The pipe will begin to rotate clockwise when viewed from the front of the tool. As the pipe rotates, begin forming the groove by pumping the handle of the hydraulic hand pump slowly.

NOTICE

- **Do not pump the handle of the hydraulic hand pump too fast. The rate should be sufficient to groove the pipe and maintain audible, moderate-to-heavy load on the motor/drive.**



12. Continue the grooving process until the depth adjuster lock comes into contact with the top of the tool body. Continue pipe rotation for several revolutions to ensure groove completion.

- 12a. Release the safety foot switch, and withdraw foot from the switch.



13. Open the valve on the hydraulic hand pump by turning it counterclockwise to release the pipe. Remove the pipe from the tool.
14. If no more roll grooving will be performed for a while, disconnect the tool from the electrical source.

NOTICE

- **The groove diameter must be within specification for the diameter and wall thickness of pipe. The groove diameter should be checked and adjusted, as necessary, to ensure grooves remain within specification.**

ROLL CHANGING

VE270FSD Roll Grooving Tools are designed with rolls to accommodate several pipe sizes and materials, which eliminates the need for frequent roll changes.

When a different pipe size or material is required for grooving, the upper and lower rolls must be changed. For proper roll selection, refer to the "Tool Rating and Roll Selection" section.

LOWER ROLL REMOVAL FOR ¾-INCH/ 26.9-MM AND 1 – 1 ½-INCH/33.7 – 48.3-MM SIZES

⚠ WARNING

- Always disconnect the tool from the electrical source before changing rolls.

Failure to follow this instruction could result in serious personal injury.

NOTICE

- The ¾-inch/26.9-mm and 1 – 1 ½-inch/33.7 – 48.3-mm lower roll assembly is held in position with left-hand threads and must be loosened by turning clockwise.



1. Open the valve on the hydraulic hand pump by turning it counterclockwise to allow the upper roll and arm to move to the full up position.

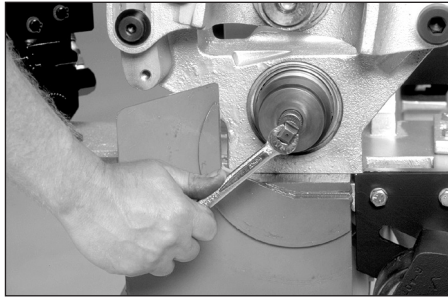

2. With a wrench engaged on the square end of the lower roll assembly, loosen and remove the lower roll assembly by turning **clockwise**. Store the lower roll assembly in the roll storage bag provided with the tool.

LOWER ROLL REMOVAL FOR 2-INCH/ 60.3-MM AND LARGER SIZES

⚠ WARNING

- Always disconnect the tool from the electrical source before changing rolls.

Failure to follow this instruction could result in serious personal injury.

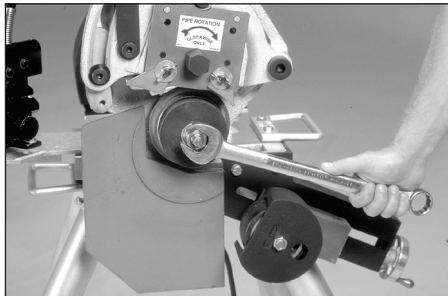

1. Using a wrench, loosen and remove the thin jam nut that secures the large nut on the arbor.

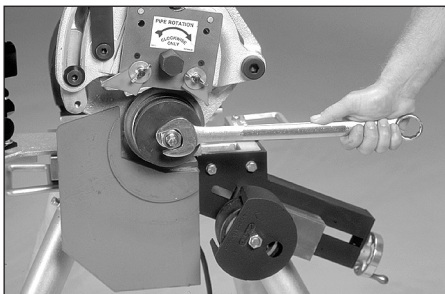

- Using a wrench, loosen the large nut on the arbor, and back it off $\frac{1}{4}$ inch/6 mm. DO NOT remove the large nut.

- Remove the nut, washer, and lower roll. Store these components in the tool cabinet.

WARNING



- Use only the aluminum wedge with a soft-faced hammer for removing the lower roll. Never strike the lower roll directly for any reason.
- Always wear eye protection when using the aluminum wedge.

Failure to follow these instructions could result in serious personal injury.

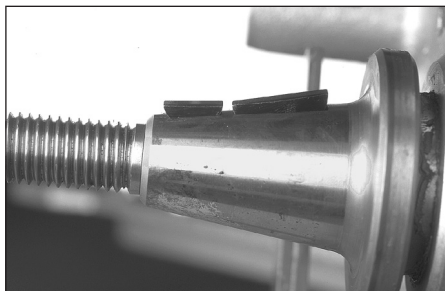

FOR KEYED-TYPE ARBORS ONLY: Be careful not to lose the Woodruff key. The Woodruff key should remain in the arbor. Inspect the Woodruff key and replace, if damaged. Spare Woodruff keys are supplied with the tool shipment. Replacement Woodruff keys must be filed or sanded until the key drags slightly in the keyway of the arbor. NEVER force a replacement key by hammering it into the arbor.

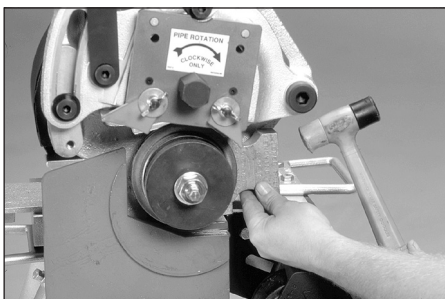

- To loosen the lower roll from the tapered arbor, use the aluminum wedge supplied with the tool. Place the wedge behind the lower roll, and strike the wedge with a soft-faced hammer to break the lower roll loose from the taper. DO NOT strike the lower roll directly with a hammer.

UPPER ROLL REMOVAL – ALL SIZES

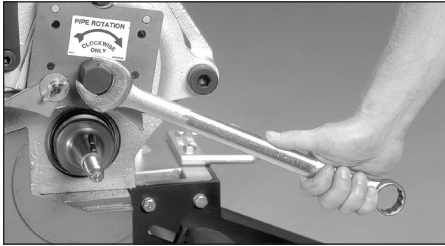

1. Using a wrench, loosen and remove the upper roll bolt. Place the upper roll bolt in a safe location.

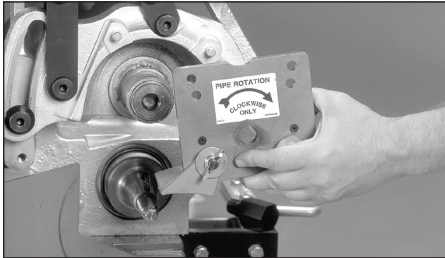

2. Remove the upper roll assembly by pulling it straight out of the tool. Store the upper roll assembly in the roll storage bag provided with the tool.

ARBOR REMOVAL FOR 2-INCH/60.3-MM AND LARGER SIZES

1. Remove the lower roll from the tool by referring to the “Lower Roll Removal for 2-inch/60.3-mm and Larger Sizes” section.

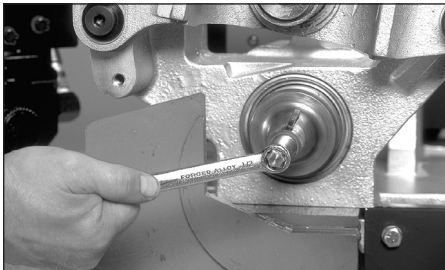

2. With a wrench engaged on the hex portion of the stud, loosen the stud by turning **counterclockwise**. The arbor should move outward as the stud is loosened.



3. When the stud has stopped moving the arbor outward, pull the arbor assembly out of the tool's main shaft. Store the arbor assembly in a safe location.

NOTICE

- The arbor could become difficult to remove from the main shaft if insufficient lubrication was applied. The arbor features three ¼ – 20 UNC tapped holes so that jack bolts can be used to push out the arbor.

CAUTION

- Never operate the tool with jack bolts installed in the arbor.

Failure to follow this instruction could result in personal injury and tool damage.

UPPER ROLL INSTALLATION – ALL SIZES



1. Prior to installation, clean all shaft surfaces and roll bores to remove any dirt and scale.

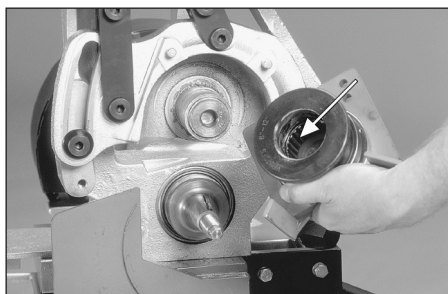

2. Inspect the roller bearing inside the upper roll for proper lubrication and movement. Inspect the roll guards for wear and freedom of movement. Repair or replace any damaged components, if necessary.

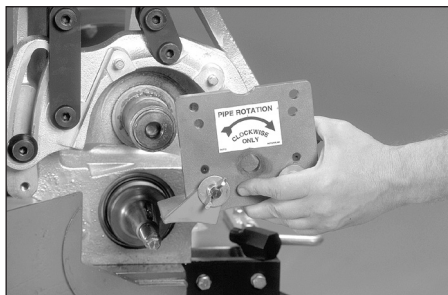

3. Slide the upper roll assembly carefully onto the upper shaft with the red plate facing out. Loosen the roll guards, if necessary, to ease installation. Make sure the red plate engages the two pins on the arm and that it contacts the front of the upper shaft.

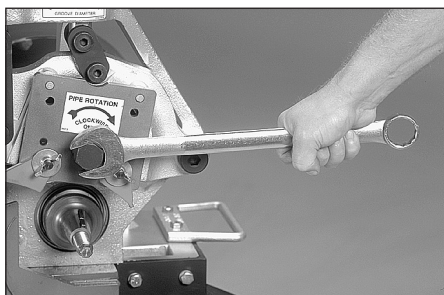

4. Insert the upper roll bolt, and tighten it securely with a wrench.

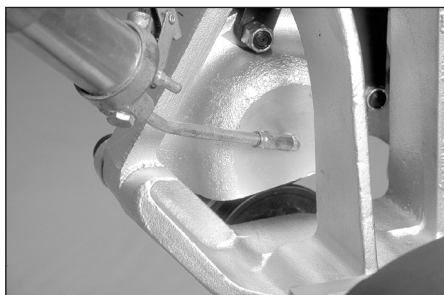

5. Lubricate upper roll bearing. Refer to the “Maintenance” section for the recommended lubricant.

**LOWER ROLL ASSEMBLY INSTALLATION FOR
3/4-INCH/26.9-MM AND 1 – 1 1/2-INCH/
33.7 – 48.3-MM SIZES**



1. Clean the bore of the main shaft and the lower roll assembly with a soft cloth.



2. Apply a light coating of mechanical assembly spray (supplied with the tool and available from Victaulic) to the lower roll assembly.

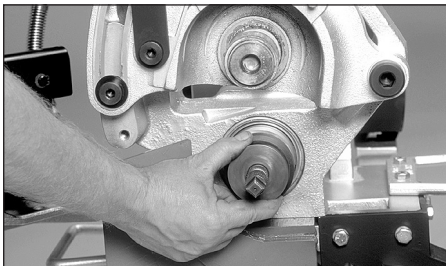

3. Insert the lower roll assembly carefully into the main shaft, making sure it is seated fully. It may be necessary to rotate the lower roll assembly to align its square back end with the main shaft.
- 3a. With a wrench engaged on the square end of the lower roll assembly, tighten the lower roll assembly by turning **counterclockwise**.

**ARBOR INSTALLATION PROCEDURE FOR
2-INCH/60.3-MM AND LARGER SIZES**



1. Clean the bore of the main shaft and the arbor with a soft cloth.

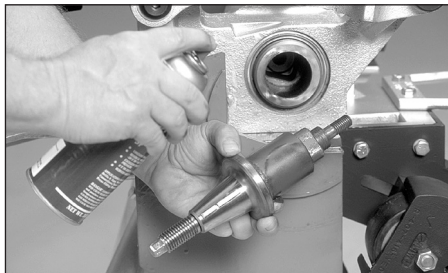

2. Apply a light coating of mechanical assembly spray (supplied with the tool and available from Victaulic) to the lower roll assembly.

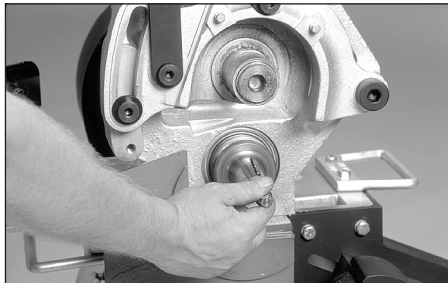

3. Insert the arbor carefully into the main shaft, making sure it is seated fully. It may be necessary to rotate the arbor to align its square back end with the main shaft.
- 3a. With a wrench engaged on the hex portion of the stud, tighten the stud by turning **clockwise**. The arbor should move inward as the stud is tightened.

**LOWER ROLL INSTALLATION FOR
2-INCH/60.3-MM AND LARGER SIZES****NOTICE**

- The arbor must be installed prior to installing 2-inch/60.3-mm and larger size lower rolls. Refer to the “Arbor Installation Procedure for 2-inch/60.3-mm and Larger Sizes” section.

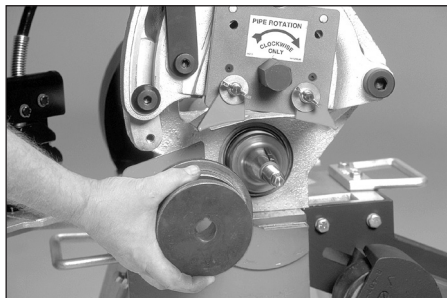
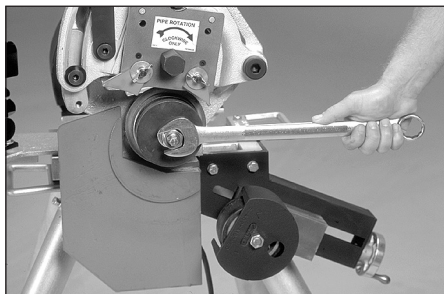

1. Install the lower roll onto the arbor.
Re-position the roll guards, if necessary, to ease installation. **FOR KEYED-TYPE ARBORS:** Make sure the lower roll fits fully onto arbor with the keys aligned with the keyway. **FOR KEYLESS-TYPE ARBORS:** Align the square drive of the lower roll with the square drive of the arbor.



2. Install the flat washer and large nut onto the threaded arbor stud. Fasten the large nut securely with a wrench to set the lower roll in position. **DO NOT** over-tighten the large nut.

3. **FOR KEYED-TYPE ARBORS ONLY:** Install the thin jam nut onto the threaded arbor stud. Tighten the thin jam nut securely against the large nut.
4. Roll set installation is now complete. Before grooving, make sure all instructions in the previous sections of this manual have been followed (i.e. adjusting the roll guards, adjusting the groove diameter stop, etc.).

MAINTENANCE**⚠ DANGER**

- Always turn off the main power supply to the tool before making any tool adjustments or before performing any maintenance.

Failure to follow this instruction could result in death or serious personal injury.

This section provides information about keeping tools in proper operating condition and guidance for making repairs when it becomes necessary. Preventive maintenance during operation will pay for itself in repair and operating savings.

Replacement parts must be ordered from Victaulic to ensure proper and safe operation of the tool.

LUBRICATION

After every 8 hours of operation, lubricate the tool. Always lubricate the upper roll bearings when rolls are changed.

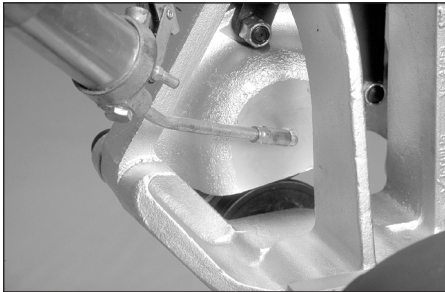

1. Grease the upper roll bearings every time roll changes are made and after every 8 hours of operation. A grease fitting is provided, as shown above. Refer to the applicable "Recommended Lubricants" table for the proper grease.

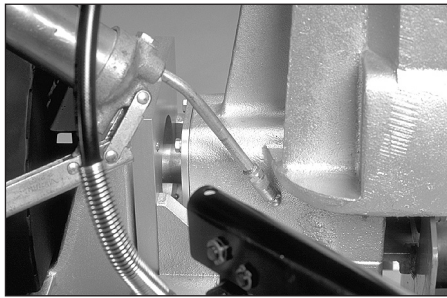

2. Grease the main shaft bearings through the grease fitting on the side of the tool, as shown above. Refer to the applicable "Recommended Lubricants" table for the proper grease.

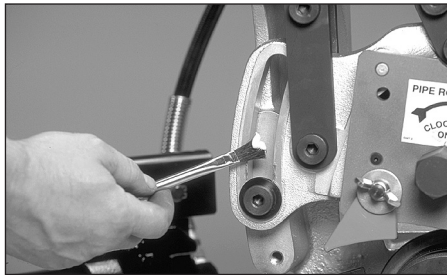

3. Lubricate the linkage mechanisms, the arm pivot point, and the arm sliding surfaces. A heavy-duty spray lubricant can be used, or apply grease by hand. Refer to the applicable "Recommended Lubricants" table for the proper grease.

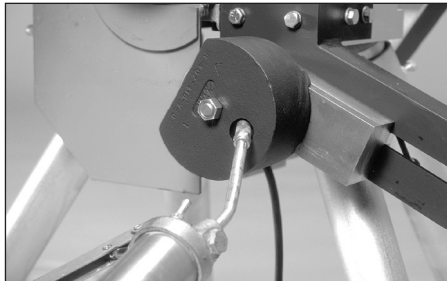

4. Lubricate the stabilizer wheel (if equipped) through the grease fitting, as shown above. Refer to the applicable "Recommended Lubricants" table for the proper grease.

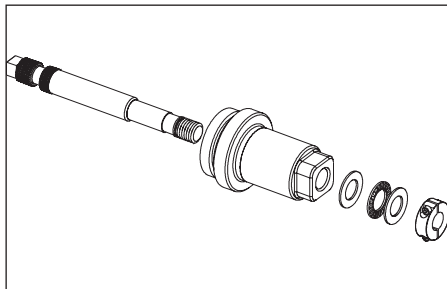
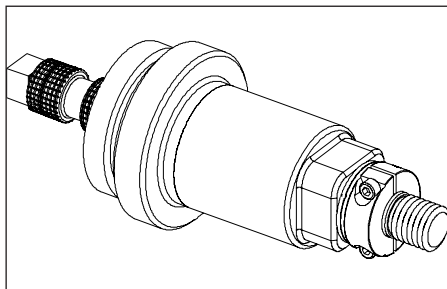

5. After every 40 hours of operation, clean and lubricate the 3/4-inch/26.9 and 1 - 1 1/2-inch/33.7 - 48.3-mm lower roll assemblies.
- 5a. Remove the cap screws and disassemble the two-piece collar. Remove the collar, needle bearing, and washers.
- 5b. Remove the lower roll from the arbor. Clean the 3/4-inch/26.9 and 1 - 1 1/2-inch/33.7 - 48.3-mm lower roll and lightly lubricate with the proper lubricant (mechanical assembly spray supplied with the tool and available from Victaulic).
- 5c. Reassemble the 3/4-inch/26.9 and 1 - 1 1/2-inch/33.7 - 48.3-mm lower roll assembly. Lubricate the needle bearing.

CHECKING AND FILLING HYDRAULIC HAND PUMP HYDRAULIC FLUID

The hydraulic fluid level in the hydraulic hand pump must be checked a minimum of every six months (depending on tool usage) or if pumping feels spongy.



1. Open the valve on the hydraulic hand pump by turning it counterclockwise.

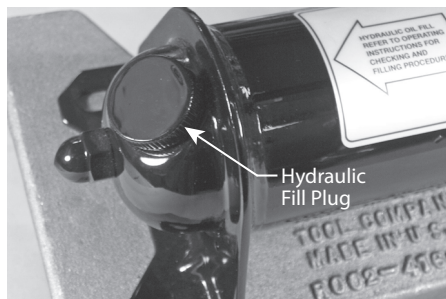

2. Remove the hydraulic fill plug at the back end of the hydraulic hand pump.
- 2a. Check the hydraulic fluid level. Add hydraulic jack oil to the bottom of the threaded port.
- 2b. Re-install the hydraulic fill plug.
- 2c. Follow the "Air Bleeding" section.

AIR BLEEDING



1. Remove the hydraulic hand pump/pump support assembly from the tool base.



2. Close the valve on the hydraulic hand pump by turning it clockwise.



3. To bleed air from the system, hold the entire hydraulic hand pump so that the hydraulic fill plug end is ABOVE the hydraulic cylinder. This will prevent siphoning of fluid from the hydraulic cylinder through the hydraulic hand pump.
4. Open the hydraulic fill plug one full turn.
5. Pump the handle of the hydraulic hand pump several strokes to build pressure.
6. Open the valve on the hydraulic hand pump by turning it counterclockwise. Allow air to escape.
7. Repeat steps 2 – 6 several times to bleed all air from the system.
8. Continue to hold the hydraulic hand pump above the hydraulic cylinder, and close the hydraulic fill plug.
9. Re-install the hydraulic hand pump/pump support assembly securely to the tool base.

RECOMMENDED LUBRICANTS**BEARING AND SLIDE GREASE**

(General Purpose EP Lithium Base Grease)

Manufacturer	Product
BP Amoco	Energrease LC-EP2
Gulf Oil Corp.	Gulfcrown Grease EP#2
Lubriplate	No. 630-2
Mobil Oil Corp.	Mobilux EP2
Pennzoil Products Co.	Pennlith EP 712 Lube
Shell Oil Co.	Alvania EP2
Sun Refining	Sun Prestige 742 EP
Texaco Inc.	Multifak EP2

HYDRAULIC OIL

(High Pressure, Anti-Wear/Anti-Foam Hydraulic Oil ISO Grade 32)

Manufacturer	Product
BP Amoco	Energol HLP-HM32
Gulf Oil Corp.	Harmony 32 AW
Kendall Refining Co.	Kenoil R&O AW-32
Lubriplate	HO-o
Mobil Oil Corp.	Mobil DTE 24
Pennzoil Products Co.	Pennzbell AW32
Shell Oil Co.	Tellus 32
Sun Refining	Survis 832
Texaco Inc.	Rando

PARTS ORDERING INFORMATION

When ordering parts, the following information is required for Victaulic to process the order and send the correct part(s). Request the RP-270FSD Repair Parts List for detailed drawings and parts listings.

1. Tool Model Number – VE270FSD
2. Tool Series Number – The serial number can be found on the side of the tool on the nameplate
3. Quantity, Part Number, and Description
4. Where to Send the Part(s) – Company name and address
5. To Whose Attention to Send the Part(s)
6. Purchase Order Number
7. Billing Address

Parts can be ordered by calling 1-800-PICK VIC.

ACCESSORIES

VAPS112 VICTAULIC ADJUSTABLE PIPE STAND



The Victaulic VAPS112 is a portable, adjustable, roller-type pipe stand that contains four legs for additional stability. Ball transfer rollers, adjustable for 2 - 12-inch/60.3 - 323.9-mm pipe, and the “V” rest for ¾ - 1½-inch/ 26.9 - 48.3-mm pipe accommodate linear and rotational movement. The turnstile design permits ease of grooving for both pipe ends. Contact Victaulic for details.

VAPS224 VICTAULIC ADJUSTABLE PIPE STAND



The Victaulic VAPS224 contains features that are similar to the VAPS112, but it is suitable for 2 – 24-inch/60.3 - 610.0-mm pipe sizes. Contact Victaulic for details.

OPTIONAL ROLLS

Refer to the applicable “Tool Rating and Roll Selection” section, which identifies rolls that are available for different pipe materials and groove specifications.

PIPE STABILIZER

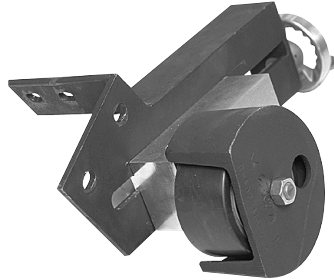

The pipe stabilizer for the VE270FSD is designed to prevent sway of short and long pipe lengths in 8 - 12-inch/219.1 - 323.9-mm sizes. The pipe stabilizer is required when grooving light-wall stainless steel pipe and 8-inch/ 206.4-mm copper tubing. Contact Victaulic for details.

TROUBLESHOOTING

PROBLEM	POSSIBLE CAUSE	SOLUTION
Pipe will not stay in grooving rolls.	Incorrect pipe positioning of long pipe length.	Refer to the “Long Pipe Lengths” section.
	Lower roll and pipe are not rotating clockwise.	Contact Victaulic.
Pipe stops rotating during the grooving operation.	Rust or dirt buildup is present on the lower roll.	Remove rust or dirt accumulation from the lower roll with a stiff wire brush.
	Rust or dirt is excessively heavy inside the pipe end.	Remove heavy rust and dirt from inside the pipe end.
	Worn grooving rolls.	Inspect the lower roll for worn knurls. Replace the lower roll if excessive wear is present.
	The motor/drive has stalled due to excessive pumping of the hydraulic hand pump.	Open the valve on the hydraulic hand pump to release the pipe. Close the valve on the hydraulic hand pump and continue grooving. Pump the hydraulic hand pump at a moderate rate.
	The main breaker has tripped and/or a fuse has blown on the electrical circuit supplying the motor/drive.	Reset the breaker and/or replace the fuse.
	The Woodruff keys are broken or missing.	Remove the lower roll and insert the punch tool into the key removal hole(s). Press out the broken key(s) and install the new keys (supplied with the tool). Re-install the lower roll.
While grooving, loud squeaks echo through the pipe.	Incorrect pipe support positioning of a long pipe length. Pipe is “over-tracking.”	Move the pipe support to the right. Refer to the “Long Pipe Lengths” section.
	Pipe is not cut square.	Cut the pipe end squarely.
	Pipe is rubbing excessively on the lower-roll backstop flange.	Remove the pipe from the tool, and apply a light coating of bandsaw blade wax to the face of the pipe end.
During grooving, loud thumps or bangs occur approximately once every revolution of the pipe.	Pipe has a pronounced weld seam.	For 12-inch/323.9-mm and smaller pipe sizes, raised internal and external weld beads and seams must be ground flush with the pipe surface 2 inches/50 mm back from the pipe ends.
Pipe flare is excessive.	Pipe support is adjusted too high for long pipe.	Refer to the “Long Pipe Lengths” section.
	Tool is tilted forward (out of level) while grooving long pipe.	Refer to the applicable “Tool Setup” section.
	Incorrect pipe support positioning of long pipe. Pipe is “over-tracking.”	Move the pipe support to the right. Refer to the “Long Pipe Lengths” section.
	Pipe stabilizer is adjusted too far inward.	Back off the pipe stabilizer to the furthest point where it still stabilizes the pipe effectively.
Larger diameter pipe sways or vibrates from side to side.	Incorrect pipe stabilizer adjustment.	Move the pipe stabilizer in or out until the pipe rotates smoothly. If the pipe stabilizer is not installed, contact Victaulic to order the kit.

TROUBLESHOOTING (CONTINUED)

PROBLEM	POSSIBLE CAUSE	SOLUTION
Tool will not groove the pipe.	The valve on the hydraulic hand pump is not closed tightly.	Tighten the valve on the hydraulic hand pump.
	The hydraulic hand pump is low on hydraulic fluid.	Refer to the "Checking and Filling Hydraulic Hand Pump Hydraulic Fluid" section.
	Air is present in the hydraulic system.	Refer to the "Air Bleeding" section.
	Pipe is beyond the wall thickness or pipe yield strength capacity of the tool.	Refer to the applicable "Tool Rating and Roll Selection" section.
Pipe groove diameters do not meet Victaulic specifications.	Groove diameter stop is not adjusted properly.	Refer to the "Groove Diameter Stop Adjustments" section.
	Pipe is beyond the wall thickness or pipe yield strength capacity of the tool.	Refer to the applicable "Tool Rating and Roll Selection" section.
The "A" Gasket Seat or "B" Groove Width dimensions do not meet Victaulic specifications.	Upper roll bearing is not lubricated adequately.	Refer to the "Maintenance" section.
	Incorrect upper roll, lower roll, or both installed on the tool	Install the correct rolls. Refer to the applicable "Tool Rating and Roll Selection" section.
	Pipe not inserted fully onto the lower roll, or pipe is not tracking properly.	Make sure pipe is against the lower-roll backstop flange. Refer to the "Long Pipe Lengths" section for proper pipe stand positioning.

TOOL RATING AND ROLL SELECTION

ORIGINAL GROOVE SYSTEM AND “ES” ROLLS FOR STEEL AND SCHEDULE 40 STAINLESS STEEL PIPE - COLOR CODED BLACK

(For light-wall stainless steel pipe, refer to separate table)

Pipe Size		Dimensions inches/millimeters				Original Groove System Type	“ES” Type
Nominal Size inches	Actual Outside Diameter inches/mm	Steel Pipe Wall Thickness		Stainless Steel Pipe Wall Thickness		Roll Part Numbers	Roll Part Numbers
		Minimum	Maximum*	Minimum	Maximum		
¾	1.050 26.9	0.065 1.7	0.113 2.9	0.065 1.7	0.113 2.9	Lower Roll R900268LA1 Upper Roll R9A0268U02	
1	1.315 33.7	0.065 1.7	0.133 3.4	0.065 1.7	0.133 3.4	Lower Roll R901268LA2 Upper Roll R9A0268U02	
1¼	1.660 42.4	0.065 1.7	0.140 3.6	0.065 1.7	0.140 3.6		
1½	1.900 48.3	0.065 1.7	0.145 3.7	0.065 1.7	0.145 3.7		
2	2.375 60.3	0.065 1.7	0.154 3.9	0.154 3.9	0.154 3.9	Lower Roll R902272L03 Upper Roll R9A2272U06	Lower Roll RZ02272L03 Upper Roll RZA2272U03
2½	2.875 73.0	0.083 2.1	0.203 5.2	0.203 5.2	0.203 5.2		
3	3.500 88.9	0.083 2.1	0.216 5.5	0.216 5.5	0.216 5.5		
3½	4.000 101.6	0.083 2.1	0.226 5.7	0.226 5.7	0.226 5.7		
4	4.500 114.3	0.083 2.1	0.375 9.5	0.237 6.0	0.237 6.0	Lower Roll R904272L06 Upper Roll R9A2272U06	Lower Roll RZ04272L06 Upper Roll RZA4272U06
4½	5.000 127.0	0.095 2.4	0.375 9.5	0.237 6.0	0.237 6.0		
5	5.563 141.3	0.109 2.8	0.375 9.5	0.258 6.6	0.258 6.6		
6	6.625 168.3	0.109 2.8	0.375 9.5	0.280 7.1	0.280 7.1		
8	8.625 219.1	0.109 2.8	0.375 9.5	0.250 6.4	0.322 8.2	Lower Roll R908272L12 Upper Roll R9A8272U12	Lower Roll RZ08272L12 Upper Roll RZA8272U12
10	10.750 273.0	0.134 3.4	0.375 9.5	0.250 6.4	0.365 9.3		
12	12.750 323.9	0.156 4.0	0.375 9.5	0.250 6.4	0.375 9.5		

* When roll grooving pipes at or near the maximum rated thickness, the pipe must not exceed the yield strength of API-5L Grade “B”, ASTM Grade “B”, 150 Brinell Hardness Number (BHN) maximum.

Types 304/304L and 316/316L stainless steel pipe

The wall thicknesses listed are nominal minimum and maximum

In addition, the following pipe sizes may be roll grooved: 76.1 mm; 108.0 mm; 133.0 mm; 139.7 mm; 152.4 mm; 159.0 mm; 165.1 mm; 203.2 mm; 216.3 mm; 254.0 mm; 267.4 mm; 304.8 mm; and 318.5 mm. Contact Victaulic for details.

**ORIGINAL GROOVE SYSTEM ROLLS FOR ALUMINUM AND PVC PLASTIC PIPE -
COLOR CODED YELLOW ZINC**

Pipe Size		Dimensions inches/millimeters				RP
Nominal Size inches	Actual Outside Diameter inches/mm	Aluminum Pipe Wall Thickness		PVC Plastic Pipe Wall Thickness		Roll Part Numbers
		Minimum	Maximum	Minimum	Maximum	
2	2.375 60.3	0.065 1.7	0.154 3.9	0.154 3.9	0.154 3.9	Lower Roll RP02272L03 Upper Roll RPA2272U06
2½	2.875 73.0	0.083 2.1	0.203 5.2	0.203 5.2	0.276 7.0	
3	3.500 88.9	0.083 2.1	0.216 5.5	0.216 5.5	0.300 7.6	
3½	4.000 101.6	0.083 2.1	0.226 5.7	0.226 5.7	0.318 8.1	
4	4.500 114.3	0.083 2.1	0.237 6.0	0.237 6.0	0.337 8.6	Lower Roll RP04272L06 Upper Roll RPA2272U06
4½	5.000 127.0	0.095 2.4	0.237 6.0			
5	5.563 141.3	0.109 2.8	0.258 6.6	0.258 6.6	0.375 9.5	
6	6.625 168.3	0.109 2.8	0.280 7.1	0.280 7.1	0.432 11.0	
8	8.625 219.1	0.109 2.8	0.322 8.2	0.322 8.2	0.322 8.2	Lower Roll RP08272L12 Upper Roll RPA8272U12
10	10.750 273.0	0.134 3.4	0.250 6.4			
12	12.750 323.9	0.156 4.0	0.250 6.4			

Aluminum Alloys 6061-T4 and 6063-T4

PVC Type 1, Grade 1 - PVC 1120; PVC Type 1, Grade II - PVC 1220; PVC Type II, Grade 1 - PVC 2116

The wall thicknesses listed are nominal minimum and maximum

For aluminum pipe, the following additional pipe sizes may be roll grooved: 76.1 mm; 108.0 mm; 133.0 mm; 139.7 mm; 152.4 mm; 159.0 mm; 165.1 mm; 203.2 mm; 216.3 mm; 254.0 mm; 267.4 mm; 304.8 mm; and 318.5 mm. Contact Victaulic for details.

For PVC pipe, the following additional pipe sizes may be roll grooved: 76.1 mm; 108.0 mm; 133.0 mm; 139.7 mm; 159.0 mm; 165.1 mm; and 216.3 mm. Contact Victaulic for details.

ORIGINAL GROOVE SYSTEM RX ROLLS FOR SCHEDULE 5S AND 10S STAINLESS STEEL PIPE - COLOR CODED SILVER

Pipe Size		Dimensions inches/millimeters		RX
Nominal Size inches	Actual Outside Diameter inches/mm	Stainless Steel Pipe Wall Thickness		Roll Part Numbers
		Minimum for Schedule 5S	Maximum for Schedule 10S	
2	2.375 60.3	0.065 1.7	0.109 2.8	Lower Roll RX02272L03 Upper Roll RXA2272U06
2½	2.875 73.0	0.083 2.1	0.120 3.0	
3	3.500 88.9	0.083 2.1	0.120 3.0	
3½	4.000 101.6	0.083 2.1	0.120 3.0	
4	4.500 114.3	0.083 2.1	0.120 3.1	Lower Roll RX04272L06 Upper Roll RXA2272U06
5	5.563 141.3	0.109 2.8	0.134 3.4	
6	6.625 168.3	0.109 2.8	0.134 3.4	
8	8.625 219.1	0.109 2.8	0.148 3.8	Lower Roll RX08272L12 Upper Roll RXA8272U12
10	10.750 273.0	0.134 3.1	0.165 4.2	
12	12.750 323.9	0.156 4.0	0.180 4.6	

Types 304/304L and 316/316L stainless steel pipe. The wall thicknesses listed are nominal minimum and maximum.

ROLLS FOR CTS US STANDARD - ASTM B-88 HARD-DRAWN COPPER TUBING AND DWV PER ASTM B-306 – COLOR-CODED COPPER

Tube Size		Dimensions inches/millimeters		Copper
Nominal Size inches	Actual Outside Diameter inches/mm	Copper Tubing Wall Thickness *		Roll Part Numbers
		Minimum	Maximum	
2	2.125 54.0	0.042 1.1	0.083 2.1	Lower Roll RR02272L06 Upper Roll RRA2272U08
2½	2.625 66.7	0.065 1.7	0.095 2.4	
3	3.125 79.4	0.045 1.1	0.109 2.8	
4	4.125 104.8	0.058 1.5	0.134 3.4	
5	5.125 130.2	0.072 1.8	0.160 4.1	
6	6.125 155.6	0.083 2.1	0.192 4.9	
8	8.125 206.4	0.109 2.8	0.271 6.9	Lower Roll RR08272L08 Upper Roll RRA2272U08

* ASTM B306, Type DWV and ASTM B88, Types K, L, M copper tubing. For grooving copper tubing to other standards, contact Victaulic. The wall thicknesses listed are nominal minimum and maximum.

EXPLANATION OF CRITICAL ROLL GROOVE DIMENSIONS

Pipe Outside Diameter - Nominal NPS Pipe Size (ANSI B36.10) and Basic Metric Pipe Size (ISO 4200) – The average pipe outside diameter must not vary from the specifications listed in the tables on the following pages. Maximum allowable pipe ovality should not vary by more than 1%. Greater variations between the major and minor diameters will result in difficult coupling assembly. For IPS pipe, the maximum allowable tolerance from square-cut pipe ends is 0.030 inch/0.8 mm for ¾ - 3½-inch/26.9 - 101.6-mm sizes; 0.045 inch/1.1 mm for 4 - 6-inch/114.3 - 168.3-mm sizes; and 0.060 inch/1.5 mm for 8-inch/219.1-mm and larger sizes. This is measured from the true square line. Any internal and external weld beads or seams must be ground flush to the pipe surface. The inside diameter of the pipe end must be cleaned to remove coarse scale, dirt, and other foreign material that might interfere with or damage grooving rolls.

“A” Dimension – The “A” dimension, or the distance from the pipe end to the groove, identifies the gasket seating area. This area must be free from indentations, projections (including weld seams), and roll marks from the pipe end to the groove to ensure a leak-tight seal. All foreign material, such as loose paint, scale, oil, grease, chips, rust, and dirt must be removed.

“B” Dimension – The “B” dimension, or groove width, controls expansion, contraction, and angular deflection of flexible couplings by the distance it is located from the pipe and its width in relation to the coupling housings’ “key” width. The bottom of the groove must be free from all foreign material, such as dirt, chips, rust, and scale that may interfere with proper coupling assembly.

“C” Dimension – The “C” dimension is the proper diameter at the base of the groove. This dimension must be within the diameter’s tolerance and concentric with the OD for proper coupling fit. The groove must be of uniform depth for the entire pipe circumference.

“D” Dimension – The “D” dimension is the normal depth of the groove and is a reference for a “trial groove” only. Variations in pipe OD affect this dimension and must be altered, if necessary, to keep the “C” dimension within tolerance. This groove must conform to the “C” dimension described above.

“F” Dimension (Original Roll Groove Only) – Maximum allowable pipe-end flare diameter is measured at the extreme pipe-end diameter.

“T” Dimension – The “T” dimension is the lightest grade (minimum, nominal wall thickness) of pipe that is suitable for cut or roll grooving. Pipe that is less than the minimum, nominal wall thickness for cut grooving may be roll grooved or adapted for Victaulic couplings by using Vic-Ring® adapters. Vic-Ring adapters can be used in the following situations (contact Victaulic for details):

- When the pipe is less than the minimum, nominal wall thickness suitable for roll grooving
- When the pipe outside diameter is too large to roll or cut groove
- When the pipe is used in abrasive services

ROLL GROOVE SPECIFICATIONS
ORIGINAL GROOVE SYSTEM FOR STEEL AND STAINLESS STEEL PIPE

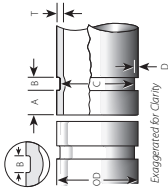

Pipe Size		Dimensions – Inches/millimeters															
		Pipe Outside Diameter		Gasket Seat "A"			Groove Width "B"			Groove Diameter "C"			Groove Depth "D" (ref.)	Min. Allow. Wall Thick. "T"	Max. Allow. Flare Dia.		
		Max.	Min.	Basic	Max.	Min.	Basic	Max.	Min.	Max.	Min.						
Nominal Size inches or mm	Actual Out. Diameter inches/mm	Max.	Min.	Basic	Max.	Min.	Basic	Max.	Min.	Basic	Max.	Min.	Max.	Min.	Max.	Min.	Max.
¾	1.050	1.060	1.040	0.625	0.656	0.594	0.281	0.312	0.250	0.281	0.312	0.250	0.938	0.923	0.056	0.049	1.15
20	26.9	26.9	26.4	15.9	16.7	15.1	7.1	7.9	6.4	7.1	7.9	6.4	23.8	23.4	1.5	1.2	29.2
25	1.315	1.328	1.302	0.625	0.656	0.594	0.281	0.312	0.250	0.281	0.312	0.250	1.190	1.175	0.063	0.049	1.43
32	1.660	1.676	1.644	0.625	0.656	0.594	0.281	0.312	0.250	0.281	0.312	0.250	1.535	1.520	0.063	0.049	1.77
40	1.900	1.919	1.881	0.625	0.656	0.594	0.281	0.312	0.250	0.281	0.312	0.250	1.775	1.760	0.063	0.049	2.01
50	2.375	2.399	2.351	0.625	0.656	0.594	0.344	0.375	0.313	0.344	0.375	0.313	2.250	2.235	0.063	0.049	2.48
65	2.875	2.904	2.846	0.625	0.656	0.594	0.344	0.375	0.313	0.344	0.375	0.313	2.720	2.702	0.078	0.078	2.98
76.1 mm	3.000	3.030	2.970	0.625	0.656	0.594	0.344	0.375	0.313	0.344	0.375	0.313	2.845	2.827	0.078	0.078	3.10
80	3.500	3.535	3.469	0.625	0.656	0.594	0.344	0.375	0.313	0.344	0.375	0.313	3.344	3.326	0.078	0.078	3.60
90	4.000	4.040	3.969	0.625	0.656	0.594	0.344	0.375	0.313	0.344	0.375	0.313	3.834	3.814	0.083	0.078	4.10
108.0 mm	4.250	4.293	4.219	0.625	0.656	0.594	0.344	0.375	0.313	0.344	0.375	0.313	4.084	4.064	0.083	0.078	4.35
4	4.500	4.545	4.469	0.625	0.656	0.594	0.344	0.375	0.313	0.344	0.375	0.313	4.334	4.314	0.083	0.078	4.60
	114.3	115.4	113.5	15.9	16.7	15.1	8.7	9.5	8.0	8.7	9.5	8.0	110.1	109.6	2.2	2.0	116.8

Table continued on the following page.

ROLL GROOVE SPECIFICATIONS
ORIGINAL GROOVE SYSTEM FOR STEEL AND STAINLESS STEEL PIPE (CONTINUED)

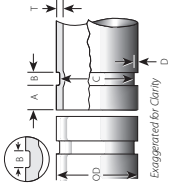

Pipe Size		Dimensions – Inches/millimeters															
		Actual Out. Diameter		Gasket Seat "A"			Groove Width "B"			Groove Diameter "C"			Groove Depth "D" (ref.)	Min. Wall Thick. "T"	Max. Allow. Flare Dia.		
		inches/mm	inches/mm	Basic	Max.	Min.	Basic	Max.	Min.	Basic	Max.	Min.					
		Max.	Min.														
4½	5.000 127.0	5.050 128.3	4.969 126.2	0.625 15.9	0.656 16.7	0.594 15.1	0.344 8.7	0.375 9.5	0.313 8.0	4.834 122.3	4.814 122.3	0.083 2.2	0.078 2.0	5.10 129.5			
133.0 mm	5.250 133.0	5.303 134.7	5.219 132.6	0.625 15.9	0.656 16.7	0.594 15.1	0.344 8.7	0.375 9.5	0.313 8.0	5.084 129.1	5.064 128.6	0.083 2.2	0.078 2.0	5.35 135.9			
139.7 mm	5.500 139.7	5.556 141.1	5.469 138.9	0.625 15.9	0.656 16.7	0.594 15.1	0.344 8.7	0.375 9.5	0.313 8.0	5.334 135.5	5.314 135.0	0.083 2.2	0.078 2.0	5.60 142.2			
5	5.563 141.3	5.619 142.7	5.532 140.5	0.625 15.9	0.656 16.7	0.594 15.1	0.344 8.7	0.375 9.5	0.313 8.0	5.395 137.0	5.373 136.5	0.084 2.2	0.078 2.0	5.66 143.8			
152.4 mm	6.000 152.4	6.056 153.8	5.969 151.6	0.625 15.9	0.656 16.7	0.594 15.1	0.344 8.7	0.375 9.5	0.313 8.0	5.830 148.1	5.808 147.5	0.085 2.2	0.078 2.0	6.10 154.9			
159.0 mm	6.260 159.0	6.313 160.4	6.219 158.0	0.625 15.9	0.656 16.7	0.594 15.1	0.344 8.7	0.375 9.5	0.313 8.0	6.032 153.2	6.002 152.5	0.109 2.8	0.109 2.8	6.35 161.3			
165.1 mm	6.500 165.1	6.563 166.7	6.469 164.3	0.625 15.9	0.656 16.7	0.594 15.1	0.344 8.7	0.375 9.5	0.313 8.0	6.330 160.8	6.308 160.2	0.085 2.2	0.078 2.0	6.60 167.6			
6	6.625 168.3	6.688 169.9	6.594 167.5	0.625 15.9	0.656 16.7	0.594 15.1	0.344 8.7	0.375 9.5	0.313 8.0	6.455 164.0	6.433 163.4	0.085 2.2	0.078 2.0	6.73 170.9			
203.2 mm	8.000 203.2	8.063 204.8	7.969 202.4	0.750 19.1	0.781 19.8	0.719 18.3	0.469 11.9	0.500 12.7	0.438 11.1	7.816 198.5	7.791 197.9	0.092 2.4	0.109 2.8	8.17 207.5			
216.3 mm	8.515 216.3	8.578 217.9	8.484 215.5	0.750 19.1	0.781 19.8	0.719 18.3	0.469 11.9	0.500 12.7	0.438 11.1	8.331 211.6	8.306 211.0	0.092 2.4	0.109 2.8	8.69 220.7			
8	8.625 219.1	8.688 220.7	8.594 218.3	0.750 19.1	0.781 19.8	0.719 18.3	0.469 11.9	0.500 12.7	0.438 11.1	8.441 214.4	8.416 213.8	0.092 2.4	0.109 2.8	8.80 223.5			

Table continued on the following page.

ROLL GROOVE SPECIFICATIONS
ORIGINAL GROOVE SYSTEM FOR STEEL AND STAINLESS STEEL PIPE (CONTINUED)

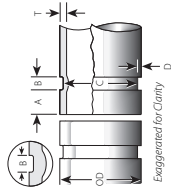

Pipe Size		Dimensions – Inches/millimeters													
Nominal Size inches or mm	Actual Out. Diameter inches/mm	Pipe Outside Diameter		Gasket Seat "A"			Groove Width "B"			Groove Diameter "C"		Groove Depth "D" (ref.)	Min. Wall Thick. "T"	Max. Allow. Flare Dia.	
		Max.	Min.	Basic	Max.	Min.	Basic	Max.	Min.	Max.	Min.				
254.0 mm	10.000	10.063	9.969	0.750	0.781	0.719	0.469	0.500	0.438	9.812	9.785	0.094	0.134	10.17	
	254.0	255.6	253.2	19.1	19.8	18.3	11.9	12.7	11.1	249.2	248.5	2.4	3.4	258.3	
267.4 mm	10.528	10.591	10.497	0.750	0.781	0.719	0.469	0.500	0.438	10.340	10.313	0.094	0.134	10.70	
	267.4	269.0	266.6	19.1	19.8	18.3	11.9	12.7	11.1	262.6	262.0	2.4	3.4	271.8	
10	10.750	10.813	10.719	0.750	0.781	0.719	0.469	0.500	0.438	10.562	10.535	0.094	0.134	10.92	
	273.0	274.7	272.3	19.1	19.8	18.3	11.9	12.7	11.1	268.3	267.6	2.4	3.4	277.4	
304.8 mm	12.000	12.063	11.969	0.750	0.781	0.719	0.469	0.500	0.438	11.781	11.751	0.109	0.156	12.17	
	304.8	306.4	304.0	19.1	19.8	18.3	11.9	12.7	11.1	299.2	298.5	2.8	4.0	309.1	
318.5 mm	12.539	12.602	12.508	0.750	0.781	0.719	0.469	0.500	0.438	12.321	12.291	0.109	0.156	12.71	
	318.5	320.1	317.7	19.1	19.8	18.3	11.9	12.7	11.1	313.0	312.2	2.8	4.0	322.8	
12	12.750	12.813	12.719	0.750	0.781	0.719	0.469	0.500	0.438	12.531	12.501	0.109	0.156	12.92	
	323.9	325.5	323.1	19.1	19.8	18.3	11.9	12.7	11.1	318.3	317.5	2.8	4.0	328.2	

ROLL GROOVE SPECIFICATIONS
ORIGINAL GROOVE SYSTEM FOR STEEL PIPE AND ALL MATERIALS GROOVED WITH "ES" ROLLS

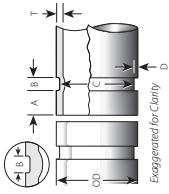

Pipe Size		Dimensions – inches/millimeters													
		Pipe Outside Diameter		Gasket Seat "A"		Groove Width "B"		Groove Diameter "C"		Groove Depth "D" (ref.)	Min. Allow. Wall Thick. "T"	Max. Allow. Flare Dia.			
Nominal Size inches/mm	Actual Out. Diameter inches/mm	Max.	Min.	Max.	Min.	Max.	Min.	Max.	Min.				Max.	Min.	Max.
4	4.500 114.3	4.545 115.4	4.469 113.5	0.590 15.5	0.610 15.5	0.320 8.1	0.300 7.6	4.314 109.6	4.334 110.1	0.083 2.1	0.237 6.0	4.600 116.8			
6	6.625 168.3	6.688 169.9	6.594 167.5	0.590 15.5	0.610 15.5	0.320 8.1	0.300 7.6	6.433 163.4	6.455 164.0	0.085 2.2	0.280 7.1	6.730 170.9			
8	8.625 219.1	8.688 220.7	8.594 218.3	0.699 17.8	0.719 18.3	0.410 10.4	0.390 9.9	8.416 213.8	8.441 214.4	0.092 2.3	0.322 8.2	8.800 223.5			
10	10.750 273.0	10.813 274.7	10.719 272.3	0.699 17.8	0.719 18.3	0.410 10.4	0.390 9.9	10.535 267.6	10.562 268.3	0.094 2.4	0.365 9.3	10.920 277.4			
12	12.750 323.9	12.813 325.5	12.719 323.1	0.699 17.8	0.719 18.3	0.410 10.4	0.390 9.9	12.501 317.5	12.531 318.3	0.109 2.8	0.375 9.5	12.920 328.2			

ROLL GROOVE SPECIFICATIONS

CTS US STANDARD - ASTM B-88 HARD-DRAWN COPPER TUBING AND DWV PER ASTM B-306

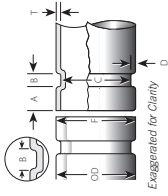

Copper Tubing Size	Dimensions – inches/mm												
	Copper Tubing Outside Diameter †		Gasket Seat "A"		Groove Width "B"		Groove Diameter "C"		Groove Depth "D" (Ref. Only)	Min. Allow. Wall Thick. "U"	Max. Allow. Flare Dia. "T"		
			Basic	Max.	Min.	Max.	Min.	Max.				Min.	Max.
Nominal Size inches/Actual mm	Max.	Min.											
2	2.127	2.123	0.610	0.640	0.580	0.330	0.300	2.009	0.048	DWV*	2.220		
54.0	54.0	53.9	15.5	16.3	14.7	8.4	7.6	51.5	1.2		56.4		
2½	2.627	2.623	0.610	0.640	0.580	0.330	0.300	2.525	0.050	0.065	2.720		
66.7	66.7	66.6	15.5	16.3	14.7	8.4	7.6	64.1	1.2	1.7	69.1		
3	3.127	3.123	0.610	0.640	0.580	0.330	0.300	3.025	0.050	DWV*	3.220		
79.4	79.4	79.3	15.5	16.3	14.7	8.4	7.6	76.8	1.2		81.8		
4	4.127	4.123	0.610	0.640	0.580	0.330	0.300	4.019	0.053	DWV*	4.220		
104.8	104.8	104.7	15.5	16.3	14.7	8.4	7.6	102.1	1.4		107.2		
5	5.127	5.123	0.610	0.640	0.580	0.330	0.300	4.999	0.063	DWV*	6.220		
130.2	130.2	130.1	15.5	16.3	14.7	8.4	7.6	127.0	1.6		132.6		
6	6.127	6.123	0.610	0.640	0.580	0.330	0.300	5.999	0.063	DWV*	6.220		
155.6	155.6	155.5	15.5	16.3	14.7	8.4	7.6	152.3	1.6		158.0		
8	8.127	8.121	0.610	0.640	0.580	0.330	0.300	7.959	0.083	DWV*	8.220		
206.4	206.4	206.3	15.5	16.3	14.7	8.4	7.6	202.2	2.1		208.8		

† The outside diameter of roll grooved copper tubing cannot vary from the tolerance listed. The maximum allowable tolerance from square cut ends is 0.030inch/0.8mm for 2 – 3-inch/54.0 – 79.4-mm sizes and 0.045inch/1.1mm for 4 – 6-inch/104.8 – 155.6-mm sizes; this is measured from the true square line.

* ASTM B-306 drain-waste and vent (DWV) is the minimum wall thickness of copper tubing that can be roll grooved.

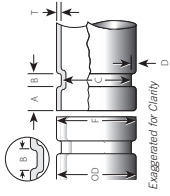

ROLL GROOVE SPECIFICATIONS
EUROPEAN STANDARD – EN 1057 R250 (HALF-HARD) COPPER TUBING

European Standard Copper Tubing Nominal Size † mm		Dimensions – mm/inches											
		Actual OD*		Gasket Seat "A"		Groove Width "B"		Groove Diameter "C"		Groove Depth "D" (Ref. Only)		Max. Allow. Flare Dia. "F"	
		Max.	Min.	Basic	Max.	Min.	Max.	Min.	Max.	Min.	Max.	Min.	Max.
54	54.07 2.129	53.93 2.123	15.87 0.625	16.64 0.655	15.11 0.595	8.38 0.330	7.62 0.300	51.51 2.028	51.00 2.008	1.25 0.049	56.38 2.220		
64	64.07 2.522	63.93 2.517	15.87 0.625	16.64 0.655	15.11 0.595	8.38 0.330	7.62 0.300	61.47 2.420	60.96 2.400	1.27 0.050	66.41 2.615		
66.7	66.77 2.629	66.63 2.623	15.87 0.625	16.64 0.655	15.11 0.595	8.38 0.330	7.62 0.300	64.14 2.525	63.63 2.505	1.27 0.050	69.09 2.720		
76.1	76.17 2.999	76.03 2.993	15.87 0.625	16.64 0.655	15.11 0.595	8.38 0.330	7.62 0.300	73.41 2.890	72.90 2.870	1.35 0.053	78.61 3.095		
88.9	88.97 3.503	88.83 3.497	15.87 0.625	16.64 0.655	15.11 0.595	8.38 0.330	7.62 0.300	85.70 3.374	85.19 3.354	1.60 0.063	91.63 3.607		
108	108.07 4.255	107.93 4.249	15.87 0.625	16.64 0.655	15.11 0.595	8.38 0.330	7.62 0.300	104.80 4.126	104.29 4.106	1.60 0.063	110.54 4.352		
133	133.20 5.244	132.80 5.228	15.87 0.625	16.64 0.655	15.11 0.595	8.38 0.330	7.62 0.300	129.29 5.090	128.78 5.070	1.85 0.073	135.79 5.346		
159	159.20 6.280	158.80 6.252	15.87 0.625	16.64 0.655	15.11 0.595	8.38 0.330	7.62 0.300	155.30 6.114	154.79 6.094	1.85 0.073	161.80 6.370		

† European Standard Copper Tubing: Nominal EN 1057 drawn copper tubing size

* The outside diameter of roll grooved copper tubing cannot vary from the tolerance listed. The maximum allowable tolerance from square cut ends is 0.8mm/0.030inch for 54 – 88.9-mm sizes and 1.1 mm 0.045inch for 108 – 159-mm sizes; this is measured from the true square line.

ROLL GROOVE SPECIFICATIONS

AUSTRALIAN STANDARD – AS 1432 TABLES A, B, AND D COPPER TUBING

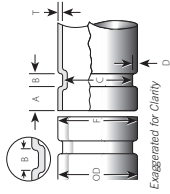

Australian Standard Copper Tubing Nominal Size (Actual Size)		Dimensions – mm/inches											
		Actual OD*		Gasket Seat "A"		Groove Width "B"		Groove Diameter "C"		Groove Depth "D" (Ref. Only)		Max. Allow. Flare Dia. "F"	
Max.	Min.	Basic	Max.	Min.	Max.	Min.	Max.	Min.	Max.	Min.	Max.	Min.	Max.
DN 50 (50.8)	50.80 2.000	50.67 1.995	15.87 0.625	16.64 0.655	15.11 0.595	8.38 0.330	7.62 0.300	48.21 1.898	47.70 1.878	1.25 0.049	53.06 2.089		
DN 65 (63.5)	63.50 2.500	63.35 2.494	15.87 0.625	16.64 0.655	15.11 0.595	8.38 0.330	7.62 0.300	60.88 2.397	60.38 2.377	1.27 0.050	65.38 2.592		
DN 80 (76.2)	76.20 3.000	76.02 2.993	15.87 0.625	16.64 0.655	15.11 0.595	8.38 0.330	7.62 0.300	73.56 2.896	73.05 2.876	1.27 0.050	78.51 3.091		
DN 100 (101.6)	101.60 4.000	101.35 3.990	15.87 0.625	16.64 0.655	15.11 0.595	8.38 0.330	7.62 0.300	98.78 3.889	98.27 3.869	1.35 0.053	103.88 4.090		
DN 125 (127.0)	127.00 5.000	126.75 4.990	15.87 0.625	16.64 0.655	15.11 0.595	8.38 0.330	7.62 0.300	123.67 4.869	123.16 4.849	1.60 0.063	128.77 5.070		
DN 150 (152.4)	152.40 6.000	152.10 5.988	15.87 0.625	16.64 0.655	15.11 0.595	8.38 0.330	7.62 0.300	149.05 5.868	148.54 5.848	1.60 0.063	154.66 6.089		

† Nominal AS 1432 drawn copper tubing size

* The outside diameter of roll grooved copper tubing cannot vary from the tolerance listed. The maximum allowable tolerance from square cut ends is 0.8mm/0.030inch for DN 50 – 80-mm sizes and 1.1mm/0.045inch for DN 100 – 150-mm sizes; this is measured from the true square line.

VE270FSD and VE271FSD

PIPE ROLL GROOVING TOOLS

For complete contact information, visit www.victaulic.com

TM-VE270/271FSD 2469 REV C UPDATED 03/2010 RM00270000

VICTAULIC IS A REGISTERED TRADEMARK OF VICTAULIC COMPANY. © 2010 VICTAULIC COMPANY.
ALL RIGHTS RESERVED. PRINTED IN THE USA.



VE416FS and VE416FSD Roll Grooving Tools



VE416FSD Shown Above

PARTS ORDERING INFORMATION

When ordering parts, the following information is necessary for Victaulic to process the order promptly:

1. Tool Model Number – VE416FS or VE416FSD
2. Tool Serial Number – The Serial Number can be found on the side of the tool.
3. Quantity, Item Number, Part Number, Description
4. Where to send the part(s) – Company Name and Address
5. To whose attention to send the part(s)
6. Purchase Order Number

Parts may be ordered from the nearest Victaulic Sales Office listed on the last page.

VE416FS and VE416FSD Roll Grooving Tools

VE416FS MAIN ASSEMBLY

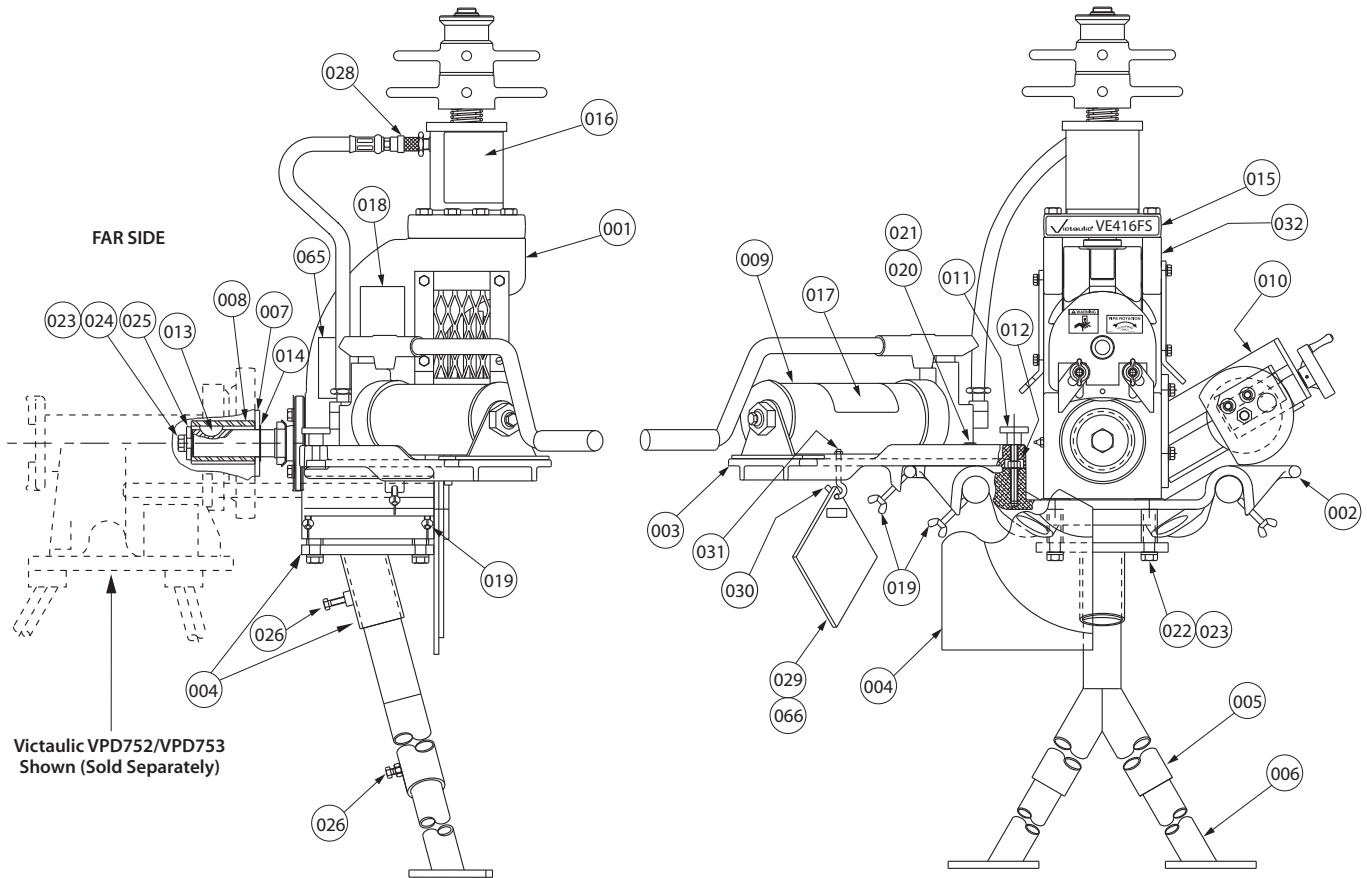

Victaulic VPD752/VPD753
Shown (Sold Separately)

Item#	Part #	Qty.	Description
001	R-100-416-VE0	1	Tool Head Assembly
002	R-001-416-MAC	1	Table
003	R-002-416-MAC	1	Pump Support
004	R-028-416-WLD	1	Guard/Mounting Weldment
005	R-006-272-0FS	1	"Y" Upper Leg Support
006	R-007-272-0FS	2	Leg
007	R-007-416-PLT	1	Drive Lug Flange
008	R-008-416-PLT	1	Drive Lug
009	R-201-261-0FS	1	Hydraulic Hand Pump Assembly
010	R-400-416-VE0	1	Stabilizer Assembly
011	N-M04-000-004	1	Steel Hand Knob
012	N-N05-060-000	1	3/8 - 16 UNC Elastic Locknut, Thin
012A	N-N05-060-000	2	3/8 - 16 UNC Elastic Locknut, Thin
013	N-K01-121-000	1	Woodruff Key
014	N-T54-000-143	1	Retaining Ring
015	R-016-416-LAB	1	Identification Label#
016	R-010-414-LBL	1	Instruction Label#
017	R-062-260-LBL	1	Hydraulic Hand Pump Label#
018	R-009-424-VE0	1	"C" Diameter Label#

Item#	Part #	Qty.	Description
019	R-010-260-0FS	5	Wing Set Screw
019A	R-010-260-0FS	1	Wing Set Screw
020	N-S01-060-012	2	3/8 - 16 UNC x .75 Lg. Hex Head Cap Screw, Pltd.
021	N-W03-060-000	2	3/8 Lockwasher, Pltd.
021A	N-W03-060-000	6	3/8 Lockwasher, Pltd.
022	N-S01-800-400	4	1/2 - 13 UNC x 4.00 Lg. Hex Head Cap Screw, Pltd.
023	N-W03-080-000	5	1/2 Lockwasher, Pltd.
023A	N-W03-080-000	8	1/2 Lockwasher, Pltd.
024	N-S01-080-104	1	1/2 - 13 UNC x 1.25 Lg. Hex Head Cap Screw, Pltd.
025	R-026-416-PLT	1	Drive Lug Retainer
026	N-S01-050-012	3	3/8 - 18 UNC x .75 Lg. Grd. 5 Hex Hd. Cap Screw, Pltd.
027	R-010-416-LAB	1	Standard Pipe Wall Thickness Label#
028	N-H50-000-018	1	Female Connection
029	R-039-272-0FS	1	Guard Setting Pad Assembly
030	N-S40-040-000	1	1/4 - 20 x 2.63 Lg. Hook Bolt
031	N-N01-040-000	1	1/4 - 20 UNC Hex Nut, Pltd.
032	R-070-260-VE0	1	Copper Groove Label#

Refer to pages 8 - 10 for images of product labels

VE416FS and VE416FSD Roll Grooving Tools

VE416FSD MAIN ASSEMBLY

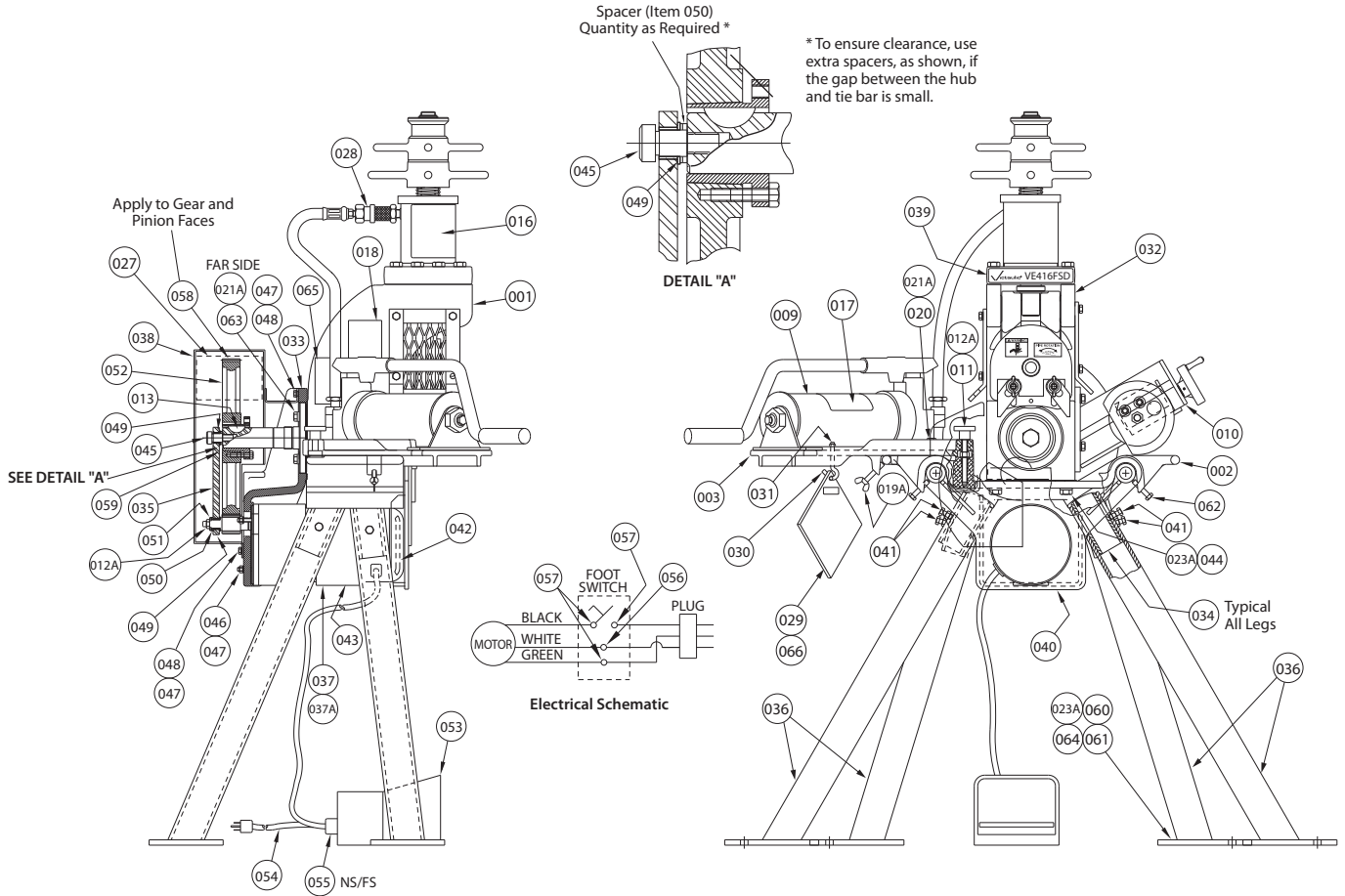

Item#	Part #	Qty.	Description
033	R-012-417-MAC	1	Motor Mounting Bracket
034	R-003-416-PLT	4	Upper Leg
035	R-014-417-PLT	1	Tie Bar
036	R-013-417-PLT	4	Lower Leg
037	R-019-417-FSD	1	Gear Motor, 120VAC, 1 Phase
037A	R-19A-416-FSD	1	Gear Motor, 220VAC, 1 Phase
038	R-015-417-PNT	1	Gear Guard
039	R-021-417-LAB	1	Identification Label#
040	R-023-417-PNT	1	Motor Guard
041	N-502-050-012	4	5/16 - 18 UNC x .75 Lg. Hex Head Cap Screw, Pltd.
042	R-020-417-FSD	1	Gear Motor Filter
043	R-022-417-LAB	1	Gear Motor Label - 120 Volt#
043A	R-22E-416-FSD	1	Gear Motor Label - 220 Volt#
044	N-S01-080-112	4	1/2 - 13 UNC x 1.75 Lg. Hex Head Cap Screw, Pltd.
045	N-S05-100-012	1	.625 x .75 Lg. Shoulder Bolt, Blk. Ox.
046	N-N02-040-000	4	1/4 - 28 UNF Hex Nut, Pltd.
047	N-W03-040-000	8	1/4 Lockwasher, Pltd.
048	N-S01-040-010	4	1/4 - 20 UNC x .63 Lg. Hex Head Cap Screw, Pltd.
049	N-B21-062-001	2	Flange Bushing

Item#	Part #	Qty.	Description
050	N-B22-062-001	1	Thrust Bushing
051	N-B40-048-001	1	Tongued Washer
052	R-037-417-MAC	1	Roll Groover Spur Gear
053	N-E03-000-002	1	Footswitch
054	N-E04-000-011	1	Line Cord (20-foot Length)
055	N-E06-000-001	2	Connector
056	-	1	Wire Nut
057	-	4	Wire Terminal
058	-	As Req.	Lubriplate Gear Shield, Heavy (Spray)
059	N-M38-000-001	1	Bushing
060	N-N01-080-000	4	1/2 - 13 Standard Hex Nut, Pltd.
061	N-W06-080-000	4	1/2 SAE Flat Washer, Pltd.
062	N-S01-050-108	4	5/16 - 18 UNC x 1.50 Lg. Hex Head Cap Screw, Pltd.
063	N-S01-060-104	4	3/8 - 16 UNC x 1.25 Lg. Hex Head Cap Screw, Pltd.
064	N-S01-080-204	4	1/2 - 13 UNC x 2.25 Lg. Grd. 5 Hex Hd. Cap Screw, Pltd.
065	R-011-424-LBL	1	"C" Diameter Label (AGS)#
066	R-077-416-ASY	1	Guard Setting Pad Assembly (AGS)
067	R-207-267-LBL	1	Groove Profile Information Label (Not Shown)#

Refer to pages 8 - 10 for images of product labels

VE416FS and VE416FSD Roll Grooving Tools

VE416FS AND VE416FSD HEAD ASSEMBLY

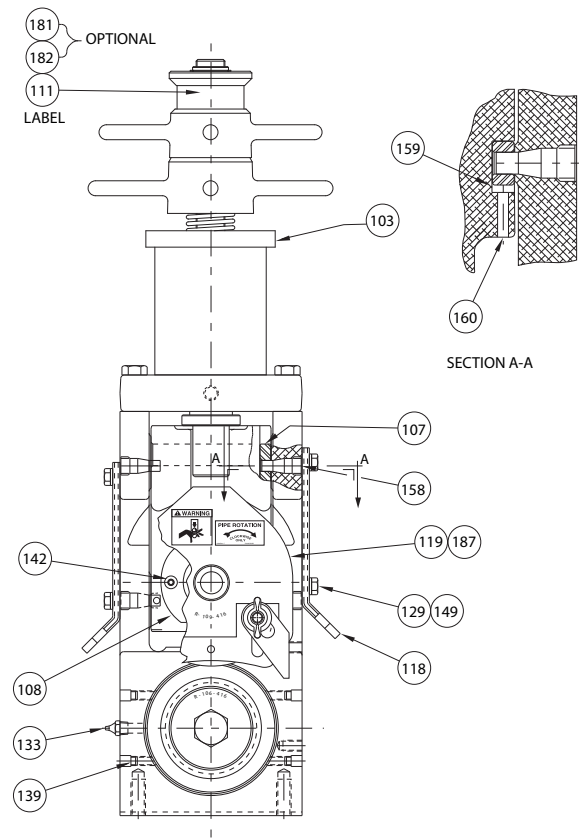
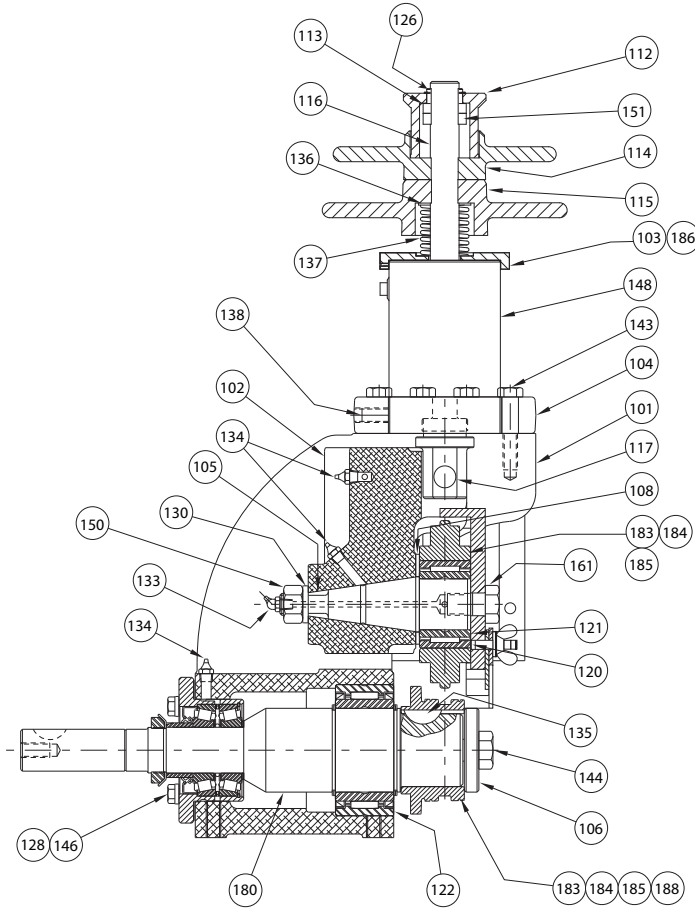

Item#	Part #	Qty.	Description
101	R-601-416-MCH	1	Tool Head Housing
102	R-602-416-MCH	1	Slide
103	R-130-416-PLT	1	Return Spring Seat *
104	R-604-416-MCH	1	Cylinder Mounting Block
105	R-105-416-MAC	1	Upper Shaft
106	R-106-416-MAC	1	Lower Roll Washer
107	R-607-416-MCH	2	Gib
108	R-108-416-MAC	1	Upper Roll Thrust Washer
111	R-111-414-LBL	1	Pipe Size Indicator Label#
112	R-112-416-PLT	1	Depth Adjuster Barrel
113	R-113-416-PLT	1	Depth Calibration Nut
114	R-114-416-PLT	1	Depth Adjuster
115	R-616-414-MCH	1	Depth Adjuster Lock *
116	R-611-414-PLT	1	Cylinder Ram *
117	R-117-416-MAC	1	Ram to Slide Pin
118	R-148-416-PNT	2	Roll Guard
119	R-035-416-0FS	1	Roll Guard Assembly (4 - 16")
120	N-B02-250-001	Ref.	Roller Bearing (Supplied with Upper Roll)
121	N-B04-175-001	1	Bearing Race
122	N-B02-350-001	1	Roller Bearing
126	N-T52-000-125	1	Retaining Ring
128	N-W03-060-000	4	3/8 Lockwasher, Pltd.
129	N-W03-050-000	6	5/16 Lockwasher, Pltd.
130	N-W03-120-000	1	3/4 Lockwasher, Pltd.
133	N-M01-000-001	2	Lubrication Fitting
134	N-M01-000-002	3	Lubrication Fitting
135	N-K01-080-900	1	Woodruff Key
136	R-615-414-PNT	1	Spring Washer *

Item#	Part #	Qty.	Description
137	N-M03-000-006	1	Compression Spring *
138	N-S80-080-100	1	1/2 - 13 UNC x 1.00 Lg. Brass Tip Set Screw
139	N-S81-050-012	4	5/16 - 18 UNC x .75 Lg. Cup Point Set Screw
142	N-S09-010-008	2	10 - 24 UNC x .50 Lg. Flat Head Socket Cap Screw, Blk. Ox.
143	N-S01-080-204	8	1/2 - 13 UNC x 2.25 Lg. Grd. 5 Hex Hd. Cap Screw, Pltd.
144	N-S02-120-104	1	3/4 - 10 UNC x 1.25 Lg. Grd. 8 Hex Hd. Cap Screw, Pltd.
145	N-M02-000-001	As Req.	Lubriplate
146	N-S01-060-104	4	3/8 - 16 UNC x 1.25 Lg. Hex Hd. Cap Screw, Pltd.
148	R-162-416-VE0	1	Cylinder
149	N-S01-050-012	6	5/16 - 18 UNC x .75 Lg. Hex Head Cap Screw, Pltd.
150	N-N01-120-000	1	3/4 - 10 UNC Hex Nut, Pltd.
151	R-151-416-PLT	1	Depth Calibration Locknut
158	R-658-416-MCH	4	Gib Screw
159	R-159-416-MAC	2	Gib Wear Plate
160	N-P01-003-100	4	.187 Dia. x 1.00 Lg. Roll Pin
161	R-030-272-0FS	1	Upper Roll Guard Cover Screw
180	R-180-416-VE0	1	Main Shaft Assembly
181	R-181-414-LBL	1	JIS and British Pipe Size Indicator Label#
182	R-182-414-LBL	1	DIN Pipe Size Indicator Label#
183	R-902-416-003	1	Standard Roll Set (2 - 3 1/2")
184	R-904-416-006	1	Standard Roll Set (4 - 6")
185	R-908-416-012	1	Standard Roll Set (8 - 12")
186	N-S81-006-006	3	#6 - 32 UNC x .38 Lg. Cup Point Set Screw *
187	R-W01-416-ASY	1	Upper Roll Assembly (AGS)
188	R-W01-416-L16	1	Lower Roll Assembly (AGS)

* Items noted with an asterisk are new components installed on VE416FS/VE416FSD tools as of January 2005.
Refer to pages 8 - 10 for images of product labels

VE416FS and VE416FSD Roll Grooving Tools

VE416FS AND VE416FSD MAIN SHAFT

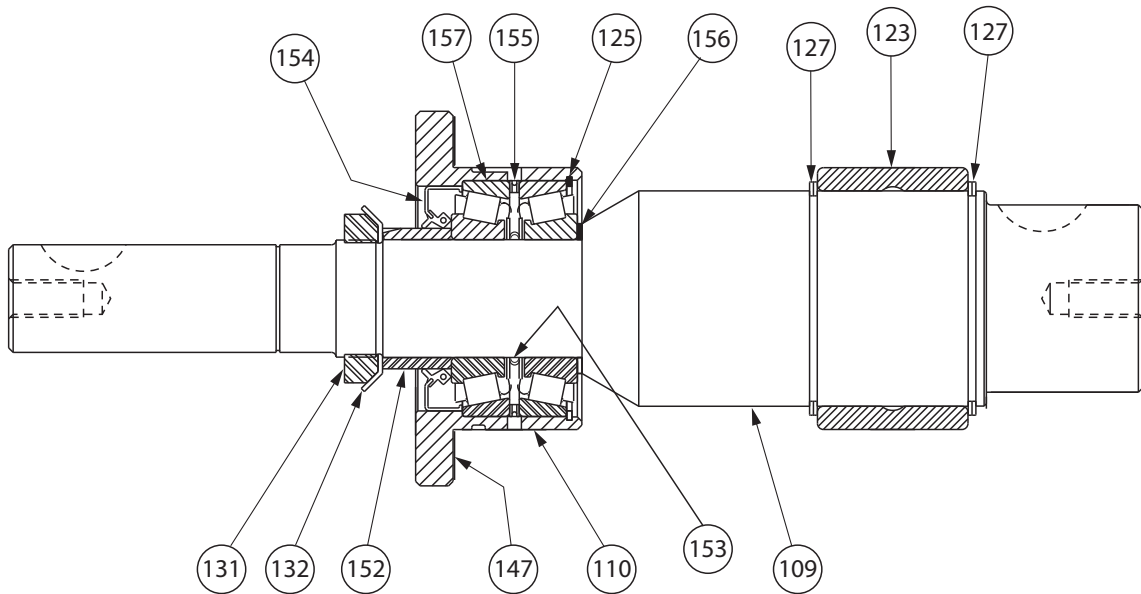

Item#	Part #	Qty.	Description
109	R-103-416-MAC	1	Main Shaft
110	R-110-416-MAC	1	Rear Bearing Housing
123	N-B04-287-001	1	Bearing Race
125	N-T53-000-314	1	Retaining Ring
127	N-T56-000-287	2	Retaining Ring
131	N-B63-000-008	1	Locknut
132	N-B61-000-108	1	Lockwasher
147**	N-B70-000-006	1	.020 Shim
	N-B70-000-005	1	.007 Shim
	N-B70-000-004	1	.005 Shim

Item#	Part #	Qty.	Description
152	R-152-416-MAC	1	Spacer
153	N-M41-000-001	1	Adjustable Spacer
154	N-M27-000-004	1	Oil Seal
155	R-155-416-MAC	1	Bearing Spacer
156	R-156-416-MAC	1	Main Shaft Spacer
157	N-B09-157-001	2	Tapered Roller Bearing

** Quantity of shims will vary depending on each unit.

VE416FS and VE416FSD Roll Grooving Tools

VE416FS AND VE416FSD HYDRAULIC HAND PUMP ASSEMBLY

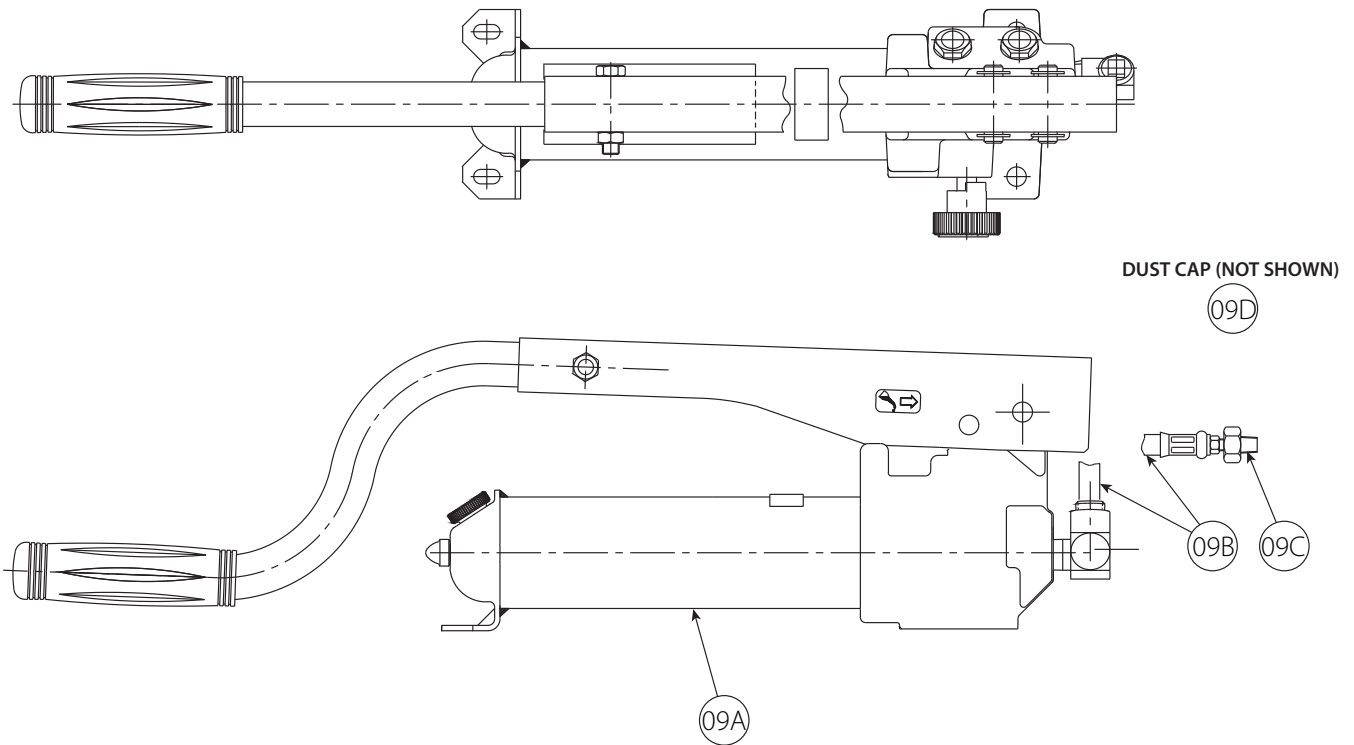

Item#	Part #	Qty.	Description
09A	R-201-261-0FS	1	Hand Pump
09B	N-H02-006-002	1	Hydraulic Hose (25-inch Length with 3/8 NPT Ends)

Item#	Part #	Qty.	Description
09C	N-H50-000-017	1	Male Hose Half Coupler
09D	N-H50-000-015	2	Dust Cap

VE416FS and VE416FSD Roll Grooving Tools

VE416FS AND VE416FSD STABILIZER ASSEMBLY

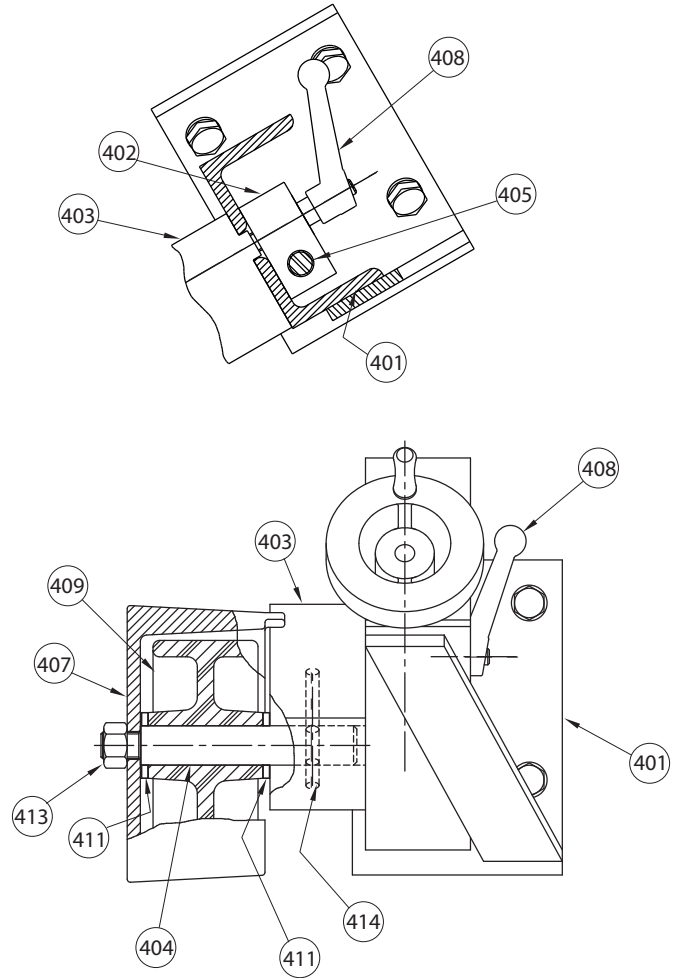
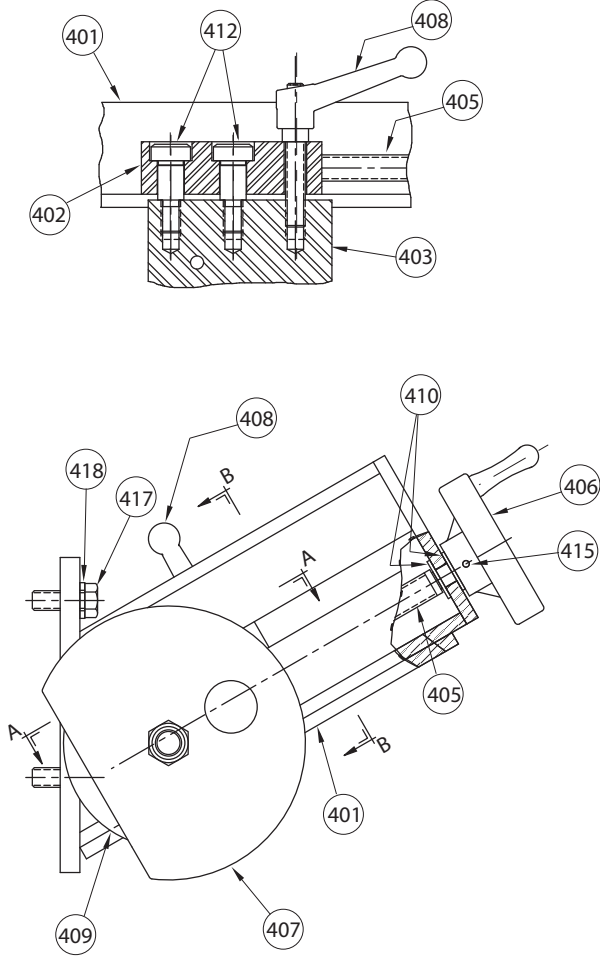

Item#	Part #	Qty.	Description
401	R-401-416-PNT	1	Stabilizer Body
402	R-402-416-PLT	1	Stabilizer Guide Nut
403	R-403-416-PLT	1	Stabilizer Guide
404	R-404-416-MAC	1	Stabilizer Roller Shaft
405	R-405-416-MAC	1	Stabilizer Adjusting Screw
406	R-406-416-MAC	1	Stabilizer Hand Wheel
407	R-407-416-PNT	1	Stabilizer Wheel Guard
408	N-M04-000-002	1	Stabilizer Locking Handle Assembly
409	N-M05-000-004	1	4 Dia. x 2 Polyurethane Wheel

Item#	Part #	Qty.	Description
410	N-B05-037-002	2	Thrust Washer
411	N-B05-075-004	2	Thrust Washer
412	N-S05-080-012	2	.50 Dia. x .75 Lg. Socket Hd. Shoulder Bolt, Blk. Ox.
413	N-N02-080-000	1	½ - 20 UNF Hex Nut, Pltd.
414	N-P01-004-208	1	.25 Dia x 2.50 Lg. Roll Pin
415	N-P01-002-102	1	.125 Dia. x 1.125 Lg. Roll Pin
417	N-S02-060-100	4	¾ - 16 x 1.00 Lg. Hex Head Cap Screw, Pltd.
418	N-W03-060-000	4	¾ Lockwasher, Pltd.

VE416FS and VE416FSD Roll Grooving Tools

IMAGES OF THE LABELS ON PAGES 8 - 10 ARE NOT TO SCALE.

R-010-414-LBL



← INCREASE DECREASE →

GROOVE DIAMETER

⚠ WARNING



Grooving rolls can crush or cut fingers and hands.

- Always disconnect the tool from the power source or switch tool off before making any tool adjustments.
- Make sure the guard is adjusted properly before grooving pipe.
- Loading/unloading pipe will place your hands close to the rollers. Keep hands away from the grooving rolls and the roller on the pipe stabilizer during operation.

- Never reach inside the pipe ends or across the tool or pipe during operation.
- Always groove pipe in a **CLOCKWISE** direction.
- Never groove pipe that is shorter than the recommended lengths listed in the operating and maintenance manual.
- Never wear loose clothing, loose gloves, or anything that can become entangled in moving parts.

⚠ WARNING



Failure to follow instructions and warnings could result in serious personal injury.

- Before operating or servicing this tool, read all instructions in the operating and maintenance manual and all labels on the tool.
- Wear safety glasses, hardhat, foot protection, and hearing protection.

If you have questions concerning the safe and proper operation of this tool, contact Victaulic, P.O. Box 31, Easton, PA 18044-0031, Phone: 1-800-PICK VIC, E-Mail: pickvic@victaulic.com.

2271 Rev. C R010414LBL

R-111-414-LBL

<p>COPPER</p> <p>2^{DW} 2M, 3-4^{DW} 2½-3M 5-6^{DW} 4M 5-6M 8M-8^{DW} V</p>	<p>SCH. 5S</p> <p>4 5-8 10-12</p>	<p>SCH. 10S</p> <p>2-3½ 4 5-8 10-12</p>	<p>SCH. 40</p> <p>2½-3½ 2 4-6 8 10-12 10</p>	<p>STD.</p> <p>4-6 8 10-12</p>	<p>SCH. 80 PVC</p> <p>2 2½ 3-3½ 4 5 6</p>	<p>AGS™ C.S.</p> <p>14" - 16" 355,6mm - 406,4mm 5,6mm Sch. 10/6,3mm Sch. 20/8,0mm 8,8mm STD. WT./9,5mm</p>	<p>AGS™ S.S.</p> <p>14" - 16" 355,6mm - 406,4mm Sch. 5S Sch. 10S Sch. 10</p>	<p>COPPER</p> <p>2L 2K 2½ L-K, 3L 3K-4L 4K, 5-6L 5K 6K 8L 8K</p>
--	--	--	--	---	--	---	---	---

4932 Rev. G R111414LBL

R-181-414-LBL

<p>BRITISH MEDIUM</p> <p>60.8x3.65 89.5x4.05 114.9x4.5</p>	<p>BRITISH HEAVY</p> <p>60.8x4.5 89.5x4.85 139.7x5.0 165.1x5.0</p>	<p>JIS</p> <p>114.3x4.9 139.8x5.1 165.2x5.0 165.2x5.5 216.3x5.8</p>	<p>76.3x4.5 89.1x4.2 114.3x4.5 139.8x4.5</p> <p>76.3x4.5 89.1x4.5 216.3x6.4 267.4x6.4 267.4x6.6 318.5x6.9</p> <p>318.5x6.4 355.6x7.9 406.4x7.9</p>
---	---	--	--

4933 Rev. C R181414LBL

R-182-414-LBL

<p>DIN 2448</p> <p>60.3 X 2.9 88.9 X 3.2 114.3 X 3.6</p> <p>76.1 X 2.9 139.7 X 4.0 406.4 X 8.8</p> <p>219.1 X 6.3 273.0 X 6.3 355.6 X 8.0</p> <p>168.3 X 4.5 323.9 X 7.1</p>	<p>DIN 2458</p> <p>60.3 X 2.3 76.1 X 2.6 88.9 X 2.9</p> <p>114.3 X 3.2 219.1 X 4.5</p> <p>139.7 X 3.6 273.0 X 5.0 323.9 X 5.6 355.6 X 5.6</p> <p>168.3 X 4.0 406.4 X 6.3</p>	<p>DIN 1.4571</p> <p>60.3 X 2.0 76.1 X 2.0 88.9 X 2.0</p> <p>108.0 X 2.0 114.3 X 2.0</p> <p>133.0 X 3.0 139.7 X 3.0 159.0 X 3.0 168.3 X 3.0 219.1 X 4.0</p>
---	---	--

4934 Rev. D R182414LBL

VE416FS and VE416FSD Roll Grooving Tools

R-009-424-LBL

ROLL GROOVE DIAMETER SPECIFICATION

SIZE	O.D.		Ø "C"	
	MAXIMUM	MINIMUM	MAXIMUM	MINIMUM
3/4 [26.9]	1.060 [26.9]	1.040 [26.4]	.938 [23.8]	.923 [23.4]
1 [33.7]	1.328 [33.7]	1.302 [33.1]	1.190 [30.2]	1.175 [29.9]
1 1/4 [42.4]	1.676 [42.6]	1.644 [41.8]	1.535 [39.0]	1.520 [38.6]
1 1/2 [48.3]	1.919 [48.7]	1.881 [47.8]	1.775 [45.1]	1.760 [44.7]
2 [60.3]	2.399 [60.9]	2.351 [59.7]	2.250 [57.2]	2.235 [56.8]
2 1/2 [73]	2.904 [73.8]	2.846 [72.3]	2.720 [69.1]	2.702 [68.6]
3 [88.9]	3.535 [89.8]	3.469 [88.1]	3.344 [84.9]	3.326 [84.5]
3 1/2 [101.6]	4.040 [102.6]	3.969 [100.8]	3.834 [97.4]	3.814 [96.9]
4 [114.3]	4.545 [115.4]	4.469 [113.5]	4.334 [110.1]	4.314 [109.6]
4 1/2 [127]	5.050 [128.3]	4.969 [126.2]	4.834 [122.8]	4.814 [122.3]
5 [141.3]	5.619 [142.7]	5.532 [140.5]	5.395 [137.0]	5.373 [136.5]
6 [168.3]	6.688 [169.9]	6.594 [167.5]	6.455 [164.0]	6.433 [163.4]
8 [219.1]	8.688 [220.7]	8.594 [218.3]	8.441 [214.4]	8.416 [213.8]
10 [273]	10.663 [255.6]	10.563 [253.2]	10.412 [249.2]	10.385 [248.5]
12 [304.8]	12.663 [306.4]	12.563 [304.0]	12.412 [299.2]	12.385 [298.5]
14 O.D. [323.9]	14.063 [325.5]	13.969 [323.1]	13.781 [318.3]	13.751 [317.5]
14 O.D. [355.6]	14.063 [357.2]	13.969 [354.8]	13.781 [350.0]	13.751 [349.3]
15 O.D. [382.6]	15.063 [382.6]	14.969 [380.2]	14.781 [375.4]	14.751 [374.7]
16 O.D. [406.4]	16.063 [408.0]	15.969 [405.6]	15.781 [400.8]	15.751 [400.1]
18 O.D. [457]	18.063 [458.8]	17.969 [456.4]	17.781 [451.6]	17.751 [450.9]
20 O.D. [508]	20.063 [509.6]	19.969 [507.2]	19.781 [502.4]	19.751 [501.7]
22 O.D. [559]	22.063 [560.4]	21.969 [558.0]	21.656 [550.1]	21.626 [549.3]
24 O.D. [610]	24.063 [611.2]	23.969 [608.8]	23.656 [600.9]	23.626 [600.1]
26 O.D. [660]	26.093 [662.8]	25.969 [659.6]	25.500 [647.7]	25.437 [646.1]
28 O.D. [711]	28.093 [713.6]	27.969 [710.4]	27.500 [698.5]	27.437 [696.9]
30 O.D. [762]	30.093 [764.4]	29.969 [761.2]	29.500 [749.3]	29.437 [747.7]
32 O.D. [813]	32.093 [815.2]	31.969 [812.0]	31.500 [800.1]	31.437 [798.5]
36 O.D. [914]	36.093 [916.8]	35.969 [913.6]	35.500 [901.7]	35.437 [900.1]
42 O.D. [1067]	42.093 [1069.2]	41.969 [1066.0]	41.500 [1052.5]	41.437 [1050.9]
48 O.D. [1219]	48.093 [1221.6]	47.969 [1218.4]	47.500 [1204.9]	47.437 [1203.3]

R-070-260-VEO

COPPER ROLL GROOVE DIAMETER SPECIFICATION

SIZE	O.D.		Ø "C"	
	MAXIMUM	MINIMUM	MAXIMUM	MINIMUM
2 [54.0]	2.127 [54.0]	2.123 [53.9]	2.029 [51.5]	2.009 [51.0]
2 1/2 [66.7]	2.627 [66.7]	2.623 [66.6]	2.525 [64.1]	2.505 [63.6]
3 [79.4]	3.127 [79.4]	3.123 [79.3]	3.025 [76.8]	3.005 [76.3]
4 [104.8]	4.127 [104.8]	4.123 [104.7]	4.019 [102.1]	3.999 [101.6]
5 [130.2]	5.127 [130.2]	5.123 [130.1]	4.999 [127.0]	4.979 [126.5]
6 [155.6]	6.127 [155.6]	6.123 [155.5]	5.999 [152.3]	5.979 [151.9]
8 [206.4]	8.127 [206.4]	8.121 [206.3]	7.959 [202.2]	7.939 [201.7]

-IMPORTANT-

USE ONLY VICTAULIC GROOVING ROLLS DESIGNED FOR COPPER TUBING (COLOR CODED COPPER)

GROOVE COPPER TUBING AT A MODERATE RATE BY UNIFORMLY FORMING GROOVES IN 5 TO 10 TUBE ROTATIONS. FORMING GROOVES AT FASTER RATES CAN RESULT IN POOR GROOVE SHARPNESS AND JOINT FAILURE.

R-011-424-LBL

Victaulic AGS™ ROLL GROOVE DIAMETER SPECIFICATION

SIZE	O.D.		Ø "C"	
	MAXIMUM	MINIMUM	MAXIMUM	MINIMUM
14 [355.6]	14.094 [358.0]	13.969 [354.8]	13.500 [342.9]	13.455 [341.8]
16 [406.4]	16.094 [408.8]	15.969 [405.6]	15.500 [393.7]	15.455 [392.6]
18 [457]	18.094 [459.6]	17.969 [456.4]	17.500 [444.5]	17.455 [443.4]
20 [508]	20.094 [510.4]	19.969 [507.2]	19.500 [495.3]	19.455 [494.2]
22 [559]	22.094 [561.2]	21.969 [558.0]	21.500 [546.1]	21.455 [545.0]
24 [610]	24.094 [612.0]	23.969 [608.8]	23.500 [596.9]	23.455 [595.8]
26 [660]	26.094 [662.8]	25.969 [659.6]	25.430 [645.9]	25.370 [644.4]
28 [711]	28.094 [713.6]	27.969 [710.4]	27.430 [696.7]	27.370 [695.2]
30 [762]	30.094 [764.4]	29.969 [761.2]	29.430 [747.5]	29.370 [746.0]
32 [813]	32.094 [815.2]	31.969 [812.0]	31.430 [798.3]	31.370 [796.8]
36 [914]	36.094 [916.8]	35.969 [913.6]	35.430 [899.9]	35.370 [898.4]
38 [965.2]	38.094 [967.6]	37.969 [964.4]	37.430 [950.7]	37.370 [949.2]
40 [1016.0]	40.094 [1018.4]	39.969 [1015.2]	39.375 [1000.1]	39.315 [998.6]
42 [1067.0]	42.094 [1069.2]	41.969 [1066.0]	41.375 [1050.9]	41.315 [1049.4]
44 [1117.6]	44.094 [1120.0]	43.969 [1116.8]	43.375 [1101.7]	43.315 [1100.2]
46 [1168.4]	46.094 [1170.8]	45.969 [1167.6]	45.375 [1152.5]	45.315 [1151.0]
48 [1219.0]	48.094 [1221.6]	47.969 [1218.4]	47.375 [1203.3]	47.315 [1201.8]
52 [1320.8]	52.094 [1323.2]	51.969 [1320.0]	51.375 [1304.9]	51.315 [1303.4]
54 [1372.0]	54.094 [1374.0]	53.969 [1370.8]	53.375 [1355.7]	53.315 [1354.2]
56 [1422.0]	56.094 [1424.8]	55.969 [1421.6]	55.375 [1406.5]	55.315 [1404.0]
60 [1524.0]	60.094 [1526.4]	59.969 [1523.2]	59.375 [1508.1]	59.315 [1506.6]
72 [1828.8]	72.094 [1831.2]	71.969 [1828.0]	71.375 [1812.9]	71.315 [1811.4]

R-207-264-LBL

Pipe and groove features, noted below, must be measured to verify they are within current Victaulic specifications. Victaulic submittal publications can be downloaded at www.victaulic.com.

OD = Average Pipe Outside Diameter
 T = Pipe Wall Thickness
 A = Distance from Pipe End to Groove
 B = Groove Width
 C = Average Diameter at Base of Groove
 D = Groove Depth
 F = Pipe-End Flare

R-062-260-LBL

HYDRAULIC OIL FILL
 Refer to operating instructions for checking and filling procedures

VIC-EASY™ ROLL GROOVING TOOL
 HYDRAULIC HAND PUMP

VE416FS and VE416FSD Roll Grooving Tools

R-010-416-LAB

 STANDARD PIPE WALL THICKNESS																			
PIPE SIZE	O.D.	SCHEDULE								PIPE SIZE	O.D.	SCHEDULE							
		5	10	20	30	40	STD	80	XStrg.			5	10	20	30	40	STD	80	XStrg.
¾	1.050	.065	.083	-	-	.113	.113	.154	.154	26	26.000	-	.312	.500	-	-	.375	-	.500
1	1.315	.065	.109	-	-	.133	.133	.179	.179	28	28.000	-	.312	.500	.625	-	.375	-	.500
1¼	1.660	.065	.109	-	-	.140	.140	.191	.191	30	30.000	-	.312	.500	.625	-	.375	-	.500
1½	1.900	.065	.109	-	-	.145	.145	.200	.200	32	32.000	-	.312	.500	.625	.688	.375	-	.500
2	2.375	.065	.109	-	-	.154	.154	.218	.218	36	36.000	-	.312	.500	.625	.750	.375	-	.500
2½	2.875	.083	.120	-	-	.203	.203	.267	.276	38	38.000	-	-	-	-	-	.375	-	.500
3	3.500	.083	.120	-	-	.216	.216	.300	.300	40	40.000	-	-	-	-	-	.375	-	.500
3½	4.000	.083	.120	-	-	.226	.226	.318	.318	42	42.000	-	-	-	-	-	.375	-	.500
4	4.500	.083	.120	-	-	.237	.237	.337	.337	44	44.000	-	-	-	-	-	.375	-	.500
5	5.563	.109	.134	-	-	.258	.258	.375	.375	46	46.000	-	-	-	-	-	.375	-	.500
6	6.625	.109	.134	-	-	.280	.280	.432	.432	48	48.000	-	-	-	-	-	.375	-	.500
8	8.625	.109	.148	.250	.277	.322	.322	.500	.500	52	52.000	-	-	-	-	-	.375	-	.500
10	10.750	.134	.165	.250	.307	.365	.365	.593	.500	54	54.000	-	-	-	-	-	.375	-	.500
12	12.750	.165	.180	.250	.330	.406	.375	.687	.500	56	56.000	-	-	-	-	-	.375	-	.500
14	14.000	-	.250	.312	.375	.437	.375	.750	.500	60	60.000	-	-	-	-	-	.375	-	.500
16	16.000	-	.250	.312	.375	.500	.375	.843	.500	64	64.000	-	-	-	-	-	.375	-	.500
18	18.000	-	.250	.312	.437	.562	.375	.937	.500	68	68.000	-	-	-	-	-	.375	-	.500
20	20.000	-	.250	.375	.500	.593	.375	1.031	.500	72	72.000	-	-	-	-	-	.375	-	.500
24	24.000	-	.250	.375	.562	.687	.375	1.281	.500	4920 Rev. D								R010416LAB	

R-016-416-LAB



R-021-417-LAB



R-022-417-LAB

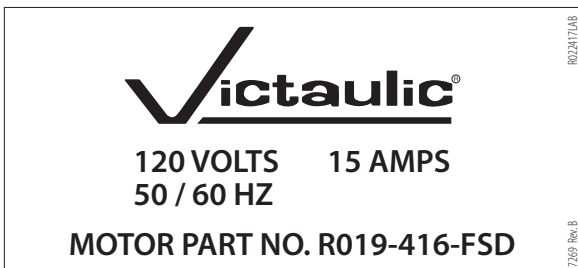

R-22E-416-FSD

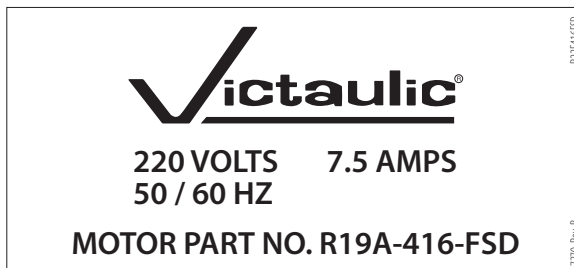

VE416FS and VE416FSD Roll Grooving Tools

For complete contact information, visit www.victaulic.com

RP-VE416FS/FSD 1459 REV G UPDATED 12/2012 RPL0416000

VICTAULIC IS A REGISTERED TRADEMARK OF VICTAULIC COMPANY. © 2012 VICTAULIC COMPANY. ALL RIGHTS RESERVED. PRINTED IN THE USA.

RP-VE416FS/FSD



RG3212 Roll Grooving Tool

**OGS**

PARTS ORDERING INFORMATION

When ordering parts, the following information is necessary for Victaulic to process the order promptly:

1. Tool Model Number – RG3212
2. Tool Serial Number – The Serial Number can be found on the side of the tool.
3. Quantity*, Item Number, Part Number, Description
4. Where to send the part(s) – Company Name and Address
5. To whose attention to send the part(s)
6. Purchase Order Number

Parts may be ordered from your nearest Victaulic Sales Office.

* Quantity given in **Qty.** column indicates total number of pieces required per tool. Value of "A/R" indicates "As Required" which may differ based on usage and environment.

MAIN ASSEMBLY

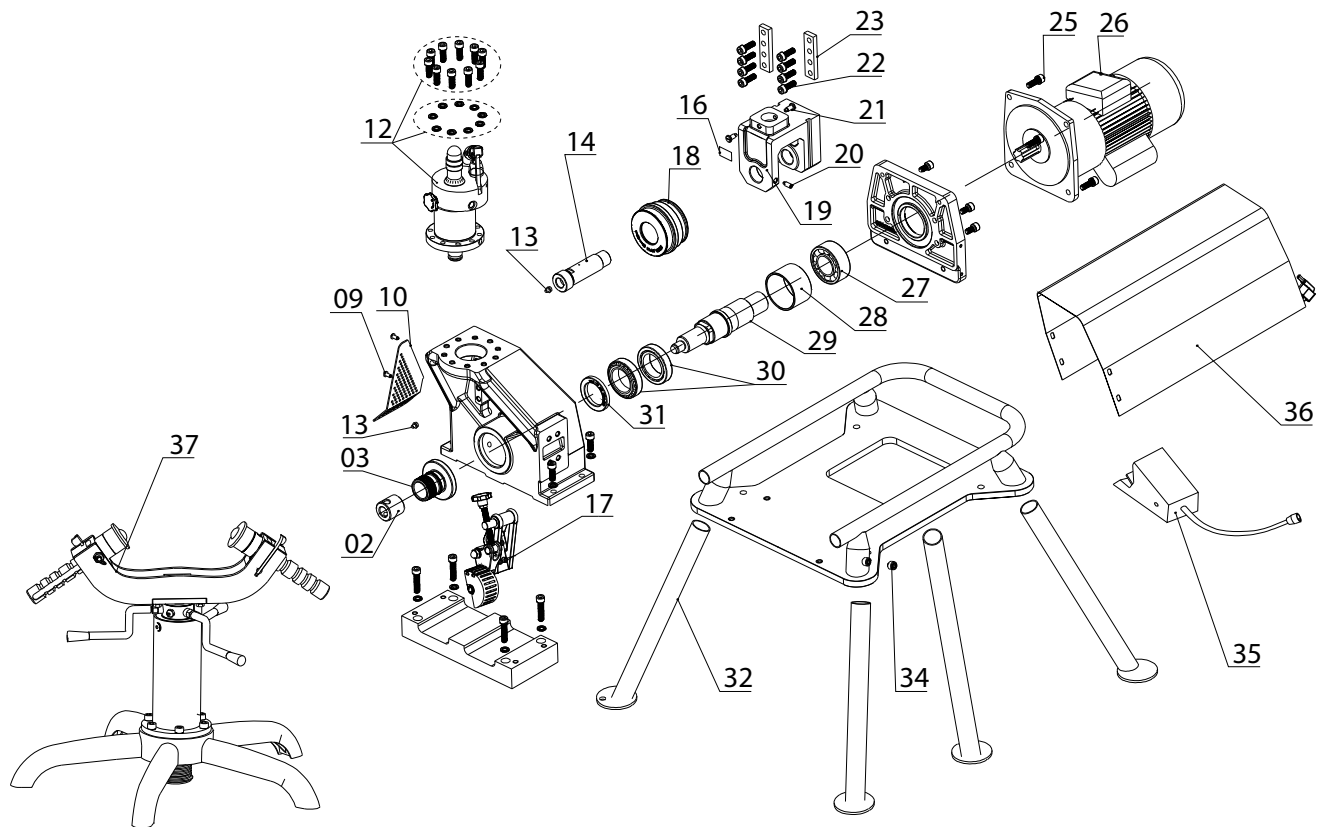

Item #	Part #	Qty.	Description
02	R000321SFN	1	Lower Roll Retaining Nut
03	see page 7		RG3212 Lower Roll
12	R000321PAY	1	Hydraulic Pump Assembly
13	R000321CUP	2	Oil Cup M10 x 1 (Grease Fitting)
16	see page 8	1	Pinch Point Label *
17	R000321STA	1	Stabilizer Wheel Assembly
18	see page 7		RG3212 Upper Roll
29	R000321MST	1	Main Shaft
35	R000321FTS	1	Foot Switch
36	R000321ECA	1	Electrical Cover Assembly
37	R000321PSA	1	Pipe Stand Assembly

* Included in assembly. Not available for individual sale.

UPPER GUIDE KIT

Item #	Part #	Qty.	Description
	R000321UGD	1	Upper Guide Kit
16	*	1	Pinch Point Label
19	*	1	Upper Roll Guide
20	*	1	Hexagon Set Screw M10 x 30
21	*	2	Piston Fixed Ring Screw
22	*	8	Hexagon Socket Head Cap Screw M10 x 20
23	*	2	Guide Rail

MOTOR AND GEARBOX KIT

Item #	Part #	Qty.	Description
	R000321MGB	1	Motor and Gearbox Replacement Kit
25	*	4	Hexagon Socket Head Cap Screw M10 x 25
26	*	1	Motor 1500W

SAFETY GUARD KIT

Item #	Part #	Qty.	Description
	R000321SGD	1	Safety Guard Kit
9	*	2	Cross Recessed Pan Head Screw M6 x 8
10	*	1	Tool Head Safety Cover

UPPER SHAFT KIT

Item #	Part #	Qty.	Description
	R000321USF	1	Upper Shaft Kit
13	*	1	Oil Cup M10 x 1 (Grease Fitting)
14	*	1	Upper Shaft
20	*	1	Hexagon Set Screw M10 x 30

MAIN SHAFT BEARING KIT

Item #	Part #	Qty.	Description
	R000321MSB	1	Main Shaft Bearing Kit
27	*	1	Rear Bearing 5208
28	*	1	Bushing
30	*	2	Front Bearing 32010
31	*	1	Seal Ring 50 x 72

LEG KIT

Item #	Part #	Qty.	Description
	R000321RPL	1	Replacement Leg Kit
32	*	1	Stand Leg 790mm
34	*	1	Hexagon Socket Head Cap Screw M10x25

HYDRAULIC PUMP ASSEMBLY (R000321PAY)

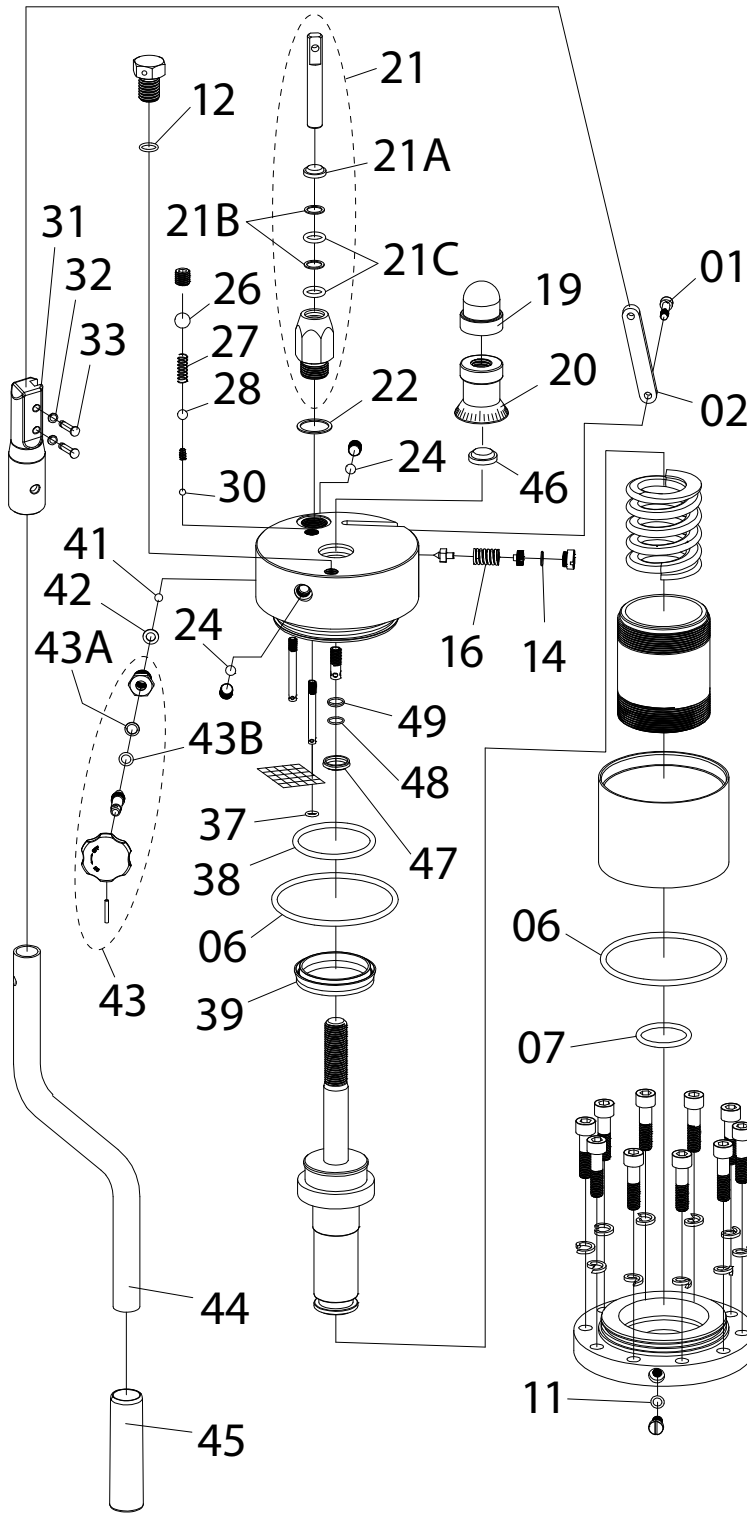

HYDRAULIC PUMP LINKAGE KIT

Item #	Part #	Qty.	Description
	R000321PLN	1	Hydraulic Pump Linkage Kit
01	*	1	Linkage Plate Fixing Screw
02	*	1	Linkage Plate
21	*	1	Hexagonal Cylinder Assembly
22	*	1	Copper Washer D28 x D22 x 1.5
31	*	1	Handle Seat
32	*	2	Lock Nut M5
33	*	2	Screw M5

* Included in assembly. Not available for individual sale.

SEAL RING SET

Item #	Part #	Qty.	Description
	R000321SRS	1	Seal Ring Set
06	*	2	O-Ring D85 x 3.1
07	*	1	O-Ring D35 x 3.1
11	*	1	O-Ring D12 x 2.4
12	*	1	O-Ring D13 x 1.9
14	*	1	O-Ring D15 x 1.9
16	*	1	Relief Valve Flat Spring
21A	*	1	Dust Seal Ring D18 x d12 x 4.5
21B	*	2	Gasket D16 x d12 x 1.6
21C	*	2	O-Ring D16 x 2.4
22	*	1	Copper Washer D28 x d22 x 1.5
24/41	*	3	Steel Ball φ6
26	*	1	Steel Ball φ9.525
27	*	1	Oil Outlet Valve Spring
28	*	1	Steel Ball φ8
30	*	1	Steel Ball φ5
37	*	1	O-Ring D8 x 1.9
38	*	1	O-Ring D60 x 3.5
39	*	1	Y-Ring D50 x d40 x 10
42	*	1	Copper Washer D12 x d8 x 1
43A	*	1	O-Ring D11 x 1.9
43B	*	1	Gasket D10.8 x d8.2 x 1.2
46	*	1	Dust Seal Ring D32 x d20 x 5
47	*	1	Y-Ring D28 x d20 x 5
48	*	1	O-Ring D24 x 2.4
49	*	1	Gasket D24 x d20 x 1.5

DEPTH STOP KIT

Item #	Part #	Qty.	Description
	R000321DST	1	Depth Stop Kit
19	*	1	Depth Stop Fastening Nut
20	*	1	Depth Stop Nut

HYDRAULIC PUMP RELIEF KNOB KIT

Item #	Part #	Qty.	Description
	R000321PRK	1	Hydraulic Pump Relief Knob Kit
41	*	1	Steel Ball φ6
42	*	1	Copper Washer D12 x D8 x 1
43	*	1	Relief Knob Assembly

HYDRAULIC PUMP HANDLE KIT

Item #	Part #	Qty.	Description
	R000321PHL	1	Hydraulic Pump Handle Kit
44	*	1	Handle
45	*	1	Handle Sleeve

PIPE STAND ASSEMBLY (R000321PSA)

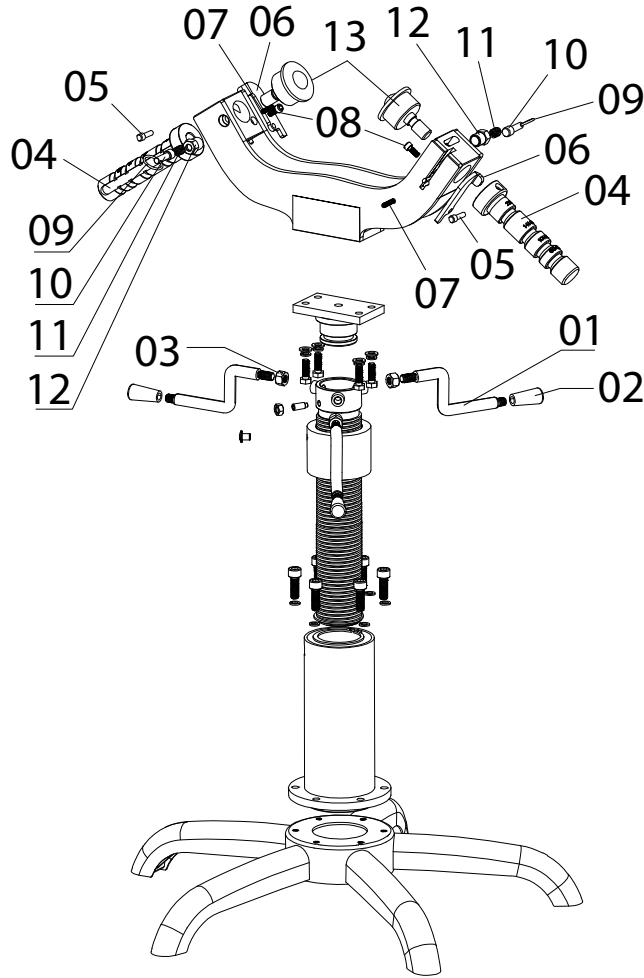

SUPPORT HANDLE KIT

Item #	Part #	Qty.	Description
	R000321SHL	1	Support Handle Kit
01	*	1	Support Handle
02	*	1	Nut
03	*	1	Handle Sleeve M10 x 40

* Included in assembly. Not available for individual sale.

PIPE STAND PIN KIT

Item #	Part #	Qty.	Description
	R000321PSP	1	Pipe Stand Pin Kit
09	*	1	Ring
10	*	1	Fasten Pin
11	*	1	Position Spring
12	*	1	Fasten Screw

PIPE STAND ADJUSTMENT SHAFT KIT

Item #	Part #	Qty.	Description
	R000321PSS	1	Pipe Stand Adjustment Shaft Kit
04	*	1	Adjustment Shaft
05	*	1	Hexagon Socket Head Cap Screw M6 x 10

PIPE STAND BEARINGS KIT

Item #	Part #	Qty.	Description
	R000321PSB	1	Pipe Stand Bearings Kit
13	*	2	CV Joint Ball

PIPE STAND ADJUSTMENT CLIP KIT

Item #	Part #	Qty.	Description
	R000321PSC	1	Pipe Stand Adjustment Clip Kit
06	*	1	Position Block
07	*	1	Position Spring
08	*	1	Hexagon Socket Head Cap Screw M6x30

STABILIZER WHEEL ASSEMBLY (R000321STA)

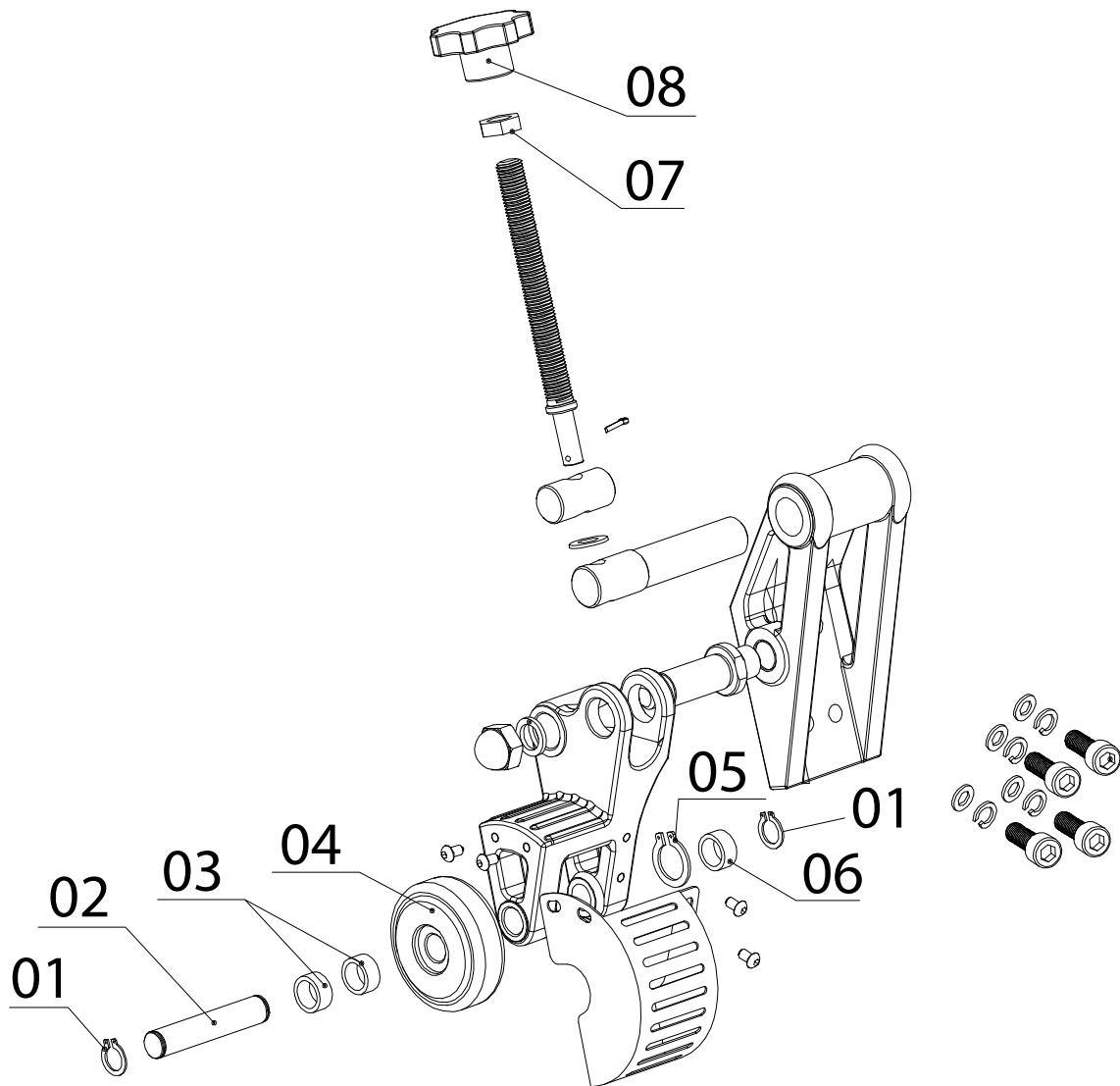

STABILIZER WHEEL KIT

Item #	Part #	Qty.	Description
	R000321SWL	1	Stabilizer Wheel Kit
01	*	2	Circlip $\phi 17$
02	*	1	Stabilizer Wheel Shaft
03	*	2	Wheel Bearing 6003RS
04	*	1	Stabilizer Wheel
05	*	1	Circlip $\phi 35$
06	*	1	Wheel Bushing

* Included in assembly. Not available for individual sale.

STABILIZER KNOB KIT

Item #	Part #	Qty.	Description
	R000321STK	1	Stabilizer Knob Kit
07	*	1	Hex Nut M16
08	*	1	Hand Knob M16X63

ELECTRICAL COVER ASSEMBLY (R000321ECA)

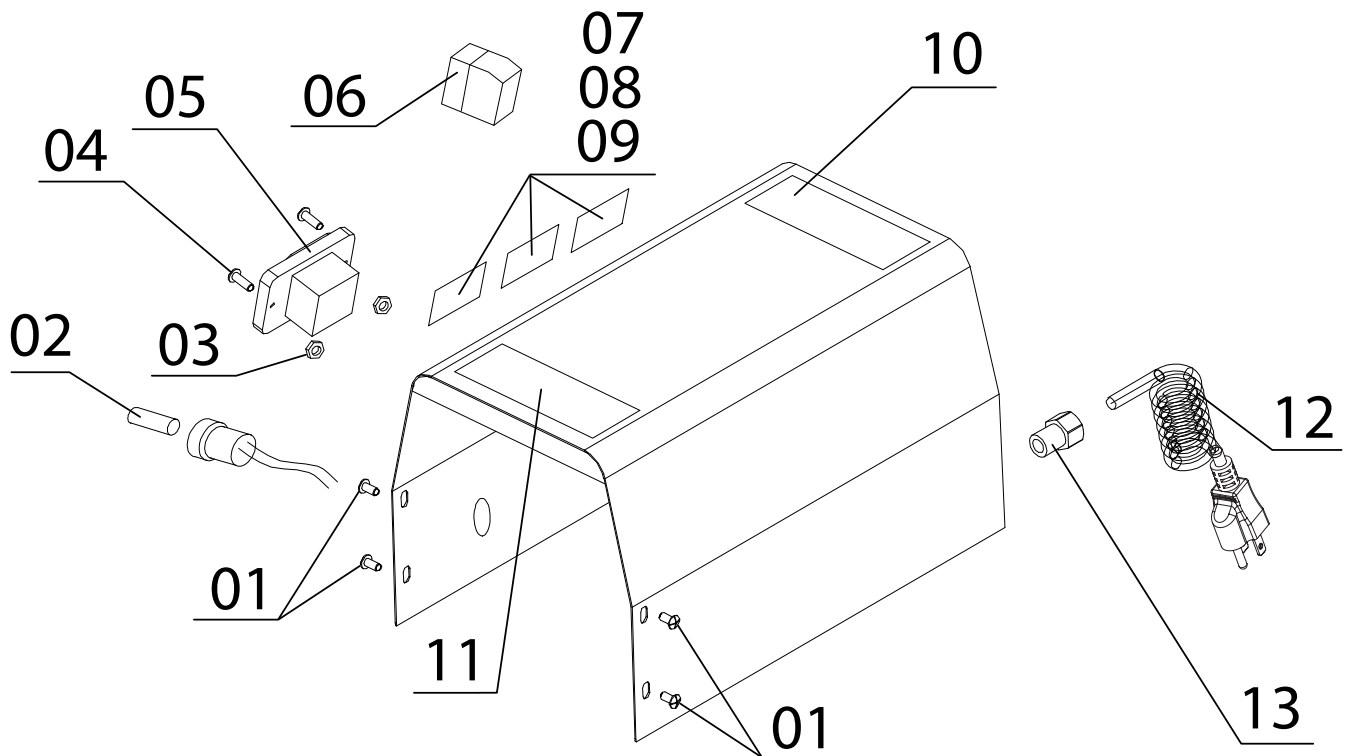

Item #	Part #	Qty.	Description
01	*	4	Cross Recessed Pan Head Screw M6 x 8
02	NELC000115	1	Fuse, 6x30mm 1A 250V AC Fast Blow
06	NELC000114	1	AC Contactor (Schneider Electric LC1D18F7)
07	see page 8	1	Warning Label for Grooving Tools *
08	see page 8	1	Roll Grooving Tool Electrical Danger Plate *
09	see page 8	1	Fuse Rating Label *
10	see page 8	1	"C" Diameter Reference Label *
11	see page 8	1	Serial Number Identification Tag *

* Included in assembly. Not available for individual sale.

SWITCH KIT

Item #	Part #	Qty.	Description
	R000321SWH	1	On/Off Switch Kit
03	*	2	Nut M4
04	*	2	Cross Recessed Pan Head Screw M4 x 16
05	*	1	Switch HY56

POWER CABLE KIT

Item #	Part #	Qty.	Description
	R000321PCB	1	Power Cable Kit
12	*	1	US Power Cable
13	*	1	Cable Strain Relief

ROLLS AND ROLL ASSEMBLIES

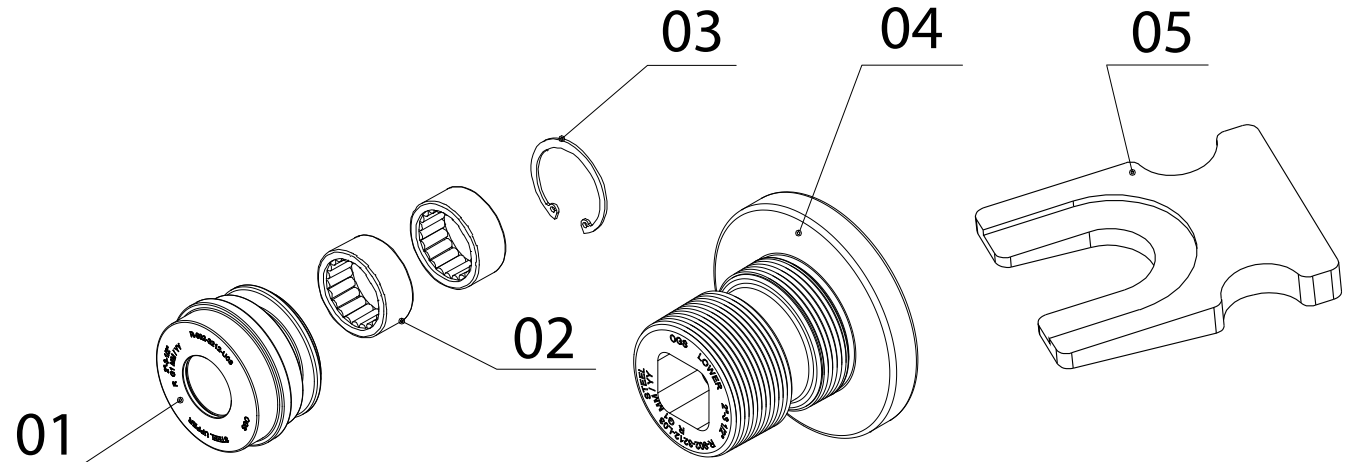

2–3.5 INCH UPPER ROLL ASSEMBLY

Item #	Part #	Qty.	Description
	R902321UA3	1	RG3212 2–3.5 inch Upper Roll Assembly
01	*	1	Upper Roll 2–3.5 inch
02	*	2	Upper Roll Bearing 4084105D
03	*	1	Circlip ϕ 47

* Included in assembly. Not available for individual sale.

LOWER ROLL

Item #	Part #	Qty.	Description
04	**		RG3212 Lower Roll
	R902321L03	1	RG3212 Lower Roll 2–3.5 inch
	R904321L06	1	RG3212 Lower Roll 4–6 inch
	R908321L12	1	RG3212 Lower Roll 8–12 inch

** Size must be specified.

4–6 INCH UPPER ROLL ASSEMBLY

Item #	Part #	Qty.	Description
	R904321UA6	1	RG3212 4–6 inch Upper Roll Assembly
01	*	1	Upper Roll 4–6 inch
02	*	2	Upper Roll Bearing 4084105D
03	*	1	Circlip ϕ 47

LOWER ROLL REMOVAL WEDGE

Item #	Part #	Qty.	Description
05	R000321LRW	1	Lower Roll Removal Wedge

8–12 INCH UPPER ROLL ASSEMBLY

Item #	Part #	Qty.	Description
	R908321A12	1	RG3212 8–12 inch Upper Roll Assembly
01	*	1	Upper Roll 8–12 inch
02	*	2	Upper Roll Bearing 4084105D
03	*	1	Circlip ϕ 47

UPPER ROLL BEARING KIT

Item #	Part #	Qty.	Description
	R000321URB	1	Upper Roll Bearing Kit
02	*	2	Upper Roll Bearing 4084105D
03	*	1	Circlip ϕ 47

RG3212 Roll Grooving Tool

LABEL KIT (IMAGES OF THE LABELS ON THIS PAGE ARE NOT TO SCALE)

01

WARNING

Failure to follow instructions and warnings could result in serious personal injury, property damage, and/or product damage.

- Before operating or servicing this tool, read the entire operating and maintenance instructions manual and all labels on the tool.
- Wear safety glasses, hardhat, foot protection, and hearing protection.
- Operate the tool only with a safety foot switch. If the tool does not contain a safety foot switch, contact Victaulic.

Contact Victaulic with questions regarding the safe and proper operation of tools:

Web: victaulic.com E-Mail: pickvic@victaulic.com Phone: 1-800-PICK-VIC

R0282260LBL
1532 Rev. D

02

DANGER

ELECTRIC SHOCK HAZARD

- ALWAYS disconnect tool from power source before performing maintenance or adjustments.

• Only authorized personnel should perform maintenance or adjustments.

Failure to follow these instructions could result in death or serious personal injury.

11469 Rev. A R111469LBL

03

ROLL GROOVE DIAMETER SPECIFICATION

13130 Rev. A R313130LBL

SIZE	O.D.		ø "C"	
	MAX.	MIN.	MAX.	MIN.
2 [60.3]	2.399 [60.9]	2.351 [59.7]	2.250 [57.2]	2.235 [56.8]
2 ½ [73.0]	2.904 [73.8]	2.846 [72.3]	2.720 [69.1]	2.702 [68.6]
3 [88.9]	3.535 [89.8]	3.469 [88.1]	3.344 [84.9]	3.326 [84.5]
3 ½ [101.6]	4.040 [102.6]	3.969 [100.8]	3.834 [97.4]	3.814 [96.9]
4 [114.3]	4.545 [115.4]	4.469 [113.5]	4.334 [110.1]	4.314 [109.6]
4 ½ [127.0]	5.050 [128.3]	4.969 [126.2]	4.834 [122.8]	4.814 [122.3]
5 [141.3]	5.619 [142.7]	5.532 [140.5]	5.395 [137.0]	5.373 [136.5]
6 [168.3]	6.688 [169.9]	6.594 [167.5]	6.455 [164.0]	6.433 [163.4]
[203.2]	8.063 [204.8]	7.969 [202.4]	7.816 [198.5]	7.791 [197.9]
8 [219.1]	8.688 [220.7]	8.594 [218.3]	8.441 [214.4]	8.416 [213.8]
[254.0]	10.063 [255.6]	9.969 [253.2]	9.812 [249.2]	9.785 [248.5]
10 [304.8]	10.813 [306.4]	10.719 [304.0]	10.562 [299.2]	10.535 [298.5]
12 [323.9]	12.813 [325.5]	12.719 [323.1]	12.531 [318.3]	12.501 [317.5]

04

RG3212

SERIAL NO.

DATE MFD.

VOLTS

PHASE

HERTZ

FULL-LOAD CURRENT

• BEARING GREASE – No. 2EP Lithium-Based Grease
 • GEAR MOTOR LUBRICANT – Spray-Type, Heavy-Duty Open Gear Lubricant
 • HYDRAULIC OIL – ISO Viscosity Grade 22
 • Always refer to the TM-RG3212 for complete Operating and Maintenance Instructions

Victaulic Company
World Headquarters
4901 Kesslersville Road
Easton, PA 18040
Phone: 1-800-PICK-VIC
pickvic@victaulic.com

Victaulic Company
No. 13, Tieshan Dong 2 Road,
DaLian Development Zone
Dalian, China 116630
Phone: 86-411-39213600
vicap@victaulic.com

Manufactured in
China
13129 Rev. B R313129LBL

05

PINCH
POINT

11240 Rev. B R211240LBL

06

FUSE RATING

6x30 mm 1A 250V AC

FAST BLOW

Item #	Part #	Qty.	Description
	R000321LBL	1	Label Kit
01	*	1	Warning Label for Grooving Tools
02	*	1	Roll Grooving Tool Electrical Danger Plate
03	*	1	"C" Diameter Reference Label
04	*	1	Serial Number Identification Tag †
05	*	1	Pinch Point Label
06	*	1	Fuse Rating Label

* Included in assembly. Not available for individual sale.
 † Customer shall retain previous plate to ensure transfer of ID information upon replacement.

VE460 Roll Grooving Tool



OGS
OGS-200
AGS[™]
EndSeal[™]

⚠ WARNING



Failure to follow instructions and warnings could result in death or serious personal injury, property damage, and product damage.

- Before operating or servicing any pipe preparation tools, read all instructions in the operating and maintenance manual and all warning labels on the tool.

- Wear safety glasses, hardhat, foot protection, and hearing protection while working around pipe preparation tools.
- Save the operating and maintenance manual in a place accessible to all operators of the tool.

If you need additional copies of any literature, or if you have questions concerning the safe and proper operation of any pipe preparation tools, contact Victaulic, P.O. Box 31, Easton, PA 18044-0031, Phone: 1-800-PICK VIC, E-Mail: pickvic@victaulic.com

Original Instructions

TABLE OF CONTENTS

Hazard Identification	2	Maintenance	49
Operator Safety Instructions	2	Lubrication	50
Introduction	4	Checking and Filling Gear Reducer Oil	51
Receiving the Tool	4	Gear Reducer Input Shaft	51
Large Container Contents	4	Checking and Filling Hydraulic Oil	52
Small Container Contents	4	Replacing Hydraulic Oil and Filter	52
Tool Return or Disposal	4	Air Bleeding	55
Power Requirements	5	Recommended Lubricants	57
Power Hookup	5	Parts Ordering Information	57
Tool Nomenclature	6	Accessories	58
Important Information for Tool Setup	7	Troubleshooting	58
Tool Dimensions and Specifications		VE460 Ratings - Maximum Pipe Size	
Without Support Bases	8	and Wall Thickness Capacity	
With Support Bases	9	(OGS and OGS-200)	60
Lifting Requirements		VE460 Ratings - Maximum Pipe Size	
Without Support Bases	10	and Wall Thickness Capacity (AGS)	60
With Support Bases	11	Roll Part Numbers	61
Tool Setup		Link to OGS Groove Specifications	63
24-inch/610-mm and Smaller Pipe	12	Link to EndSeal “ES” Groove	
26-inch/660-mm and Larger Pipe	14	Specifications	63
Verification Of Pipe Rotation Direction	20	Link to AGS Groove Specifications	63
Emergency Stop Operation	22	Links to Additional Resources	63
Preparing Pipe for Grooving	24	EC Declaration of Conformity	64
Pipe Length Requirements	24	UK Declaration of Conformity	65
Checking and Adjusting the Tool Prior to			
Grooving	26		
Grooving Rolls	26		
Adjusting the Roll Guards	26		
Pipe Stabilizer Adjustment	29		
Ram Speed Adjustment	31		
Dwell Control Adjustment	32		
Time Range Adjustment	32		
Pipe Size Adjustment	33		
Groove Diameter Stop Adjustment	33		
Grooving Long Pipe Lengths	36		
Grooving Short Pipe Lengths	40		
Roll Changing	42		
Lower Roll Removal	44		
Upper Roll Removal	45		
Upper Roll Installation	45		
Lower Roll Installation	46		

HAZARD IDENTIFICATION

Definitions for identifying the various hazard levels are provided below.



This safety alert symbol indicates important safety messages. When you see this symbol, be alert to the possibility of personal injury.

Carefully read and fully understand the message that follows.

DANGER

- The use of the word “**DANGER**” identifies an immediate hazard with a likelihood of death or serious personal injury if instructions, including recommended precautions, are not followed.

WARNING

- The use of the word “**WARNING**” identifies the presence of hazards or unsafe practices that could result in death or serious personal injury if instructions, including recommended precautions, are not followed.

CAUTION

- The use of the word “**CAUTION**” identifies possible hazards or unsafe practices that could result in personal injury and product or property damage if instructions, including recommended precautions, are not followed.

NOTICE

- The use of the word “**NOTICE**” identifies special instructions that are important but not related to hazards.

OPERATOR SAFETY INSTRUCTIONS

The VE460 Roll Grooving Tool is designed for the sole purpose of roll grooving pipe. These instructions must be read and understood by each operator PRIOR to working with the grooving tool. These instructions describe safe operation of the tool, including set up and maintenance. Each operator must become familiar with the tool's operations, applications, and limitations. Particular care should be given to reading and understanding the dangers, warnings, and cautions described throughout these operating instructions.

Use of this tool requires dexterity and mechanical skills, as well as sound safety habits. Although this tool is designed and manufactured for safe, dependable operation, it is difficult to anticipate all combinations of circumstances that could result in an accident. The following instructions are recommended for safe operation of this tool. The operator is cautioned to always practice “safety first” during each phase of use, including set up and maintenance. It is the responsibility of the lessee or user of this tool to ensure that all operators read this manual and fully understand the operation of this tool.

Store this manual in a clean, dry area where it is always readily available. Additional copies of this manual are available upon request through Victaulic, or can be downloaded at victaulic.com.

DANGER

1. **Avoid using the tool in potentially dangerous environments.** Do not expose the tool to rain, and do not use the tool in damp or wet locations. Do not use the tool on sloped or uneven surfaces. Keep the work area well lit. Allow sufficient space to operate the tool properly.
2. **Ground the tool to protect the operator from electric shock.** Ensure that the tool is connected to an internally grounded electrical source.

3. **Disconnect the power cord from the electrical source before servicing the tool.** Only authorized personnel should perform maintenance on the tool. Always disconnect the power cord from the electrical source before servicing or adjusting the tool.
4. **Prevent accidental startups.** Place the power switch in the “OFF” position before connecting the tool to an electrical source.

 **WARNING**

1. **Prevent back injury.** Always use proper lifting techniques when handling tool components.
2. **Wear proper apparel.** Do not wear loose clothing, jewelry, or anything that can become entangled in moving parts.
3. **Wear protective items when working with tools.** Always wear safety glasses, hardhat, foot protection, and hearing protection.
4. **Keep hands and tools away from grooving rolls and stabilizer roller during the grooving operation.** Grooving rolls can crush or cut fingers and hands.
5. **Do not reach inside pipe ends during tool operation.** Pipe edges can be sharp and can snag gloves, hands, and shirt sleeves.
6. **Operate the tool only with a safety foot switch.** The power drive shall be operated with a safety foot switch that is located for easy operator access. Never reach across moving parts. If the tool does not contain a safety foot switch, contact Victaulic.
7. **Do not over-reach.** Maintain proper footing and balance at all times. Ensure that the safety foot switch is easily accessible to the operator.
8. **Do not make any modifications to the tool.** Do not remove any safety guarding or any components that would affect tool performance.
9. **Do not operate the tool at ram speeds exceeding those specified in this manual.**

 **CAUTION**

1. **The VE460 tool is designed ONLY for roll grooving pipe sizes, materials, and wall thicknesses as designated.**
2. **Inspect the equipment.** Before using the tool, check moveable parts for obstructions. Ensure that tool components are installed and adjusted in accordance with the “Tool Setup” section. Ensure that properly matched roll sets are installed and lubricated.
3. **Stay alert.** Do not operate the tool if you are drowsy from medication or fatigue.
4. **Keep visitors, trainees, and observers away from the immediate work area.** All visitors should be kept a safe distance from the equipment at all times.
5. **Keep work areas clean.** Keep the work area around the tool clear of any obstructions that could limit movement of the operator. Clean up any spills.
6. **Secure the work, machine, and accessories.** Ensure that the tool is stable. Refer to the “Tool Setup” section.
7. **Support the work.** Support long pipe lengths with a pipe stand, in accordance with the “Long Pipe/Tubing Lengths” section.
8. **Do not force the tool.** Do not force the tool or accessories to perform any functions beyond the capabilities described in these instructions. Do not overload the tool.
9. **Maintain tool with care.** Keep the tool clean at all times to ensure proper and safe performance. Follow the instructions for lubricating tool components.
10. **Use only Victaulic replacement parts and accessories.** Use of any other parts may result in a voided warranty, improper operation, and hazardous situations. Refer to the “Parts Ordering Information” and “Accessories” sections.
11. **Do not remove any labels from the tool.** Replace any damaged or worn labels.

INTRODUCTION

NOTICE

- Drawings and/or pictures in this manual may be exaggerated for clarity.
- The tool, along with this operating and maintenance instructions manual, contains trademarks, copyrights, and/or patented features that are the exclusive property of Victaulic.

The VE460 Roll Grooving Tool is a motorized, semi-automatic, hydraulic-feed tool for roll grooving pipe to receive Victaulic grooved pipe products. The VE460 tool is supplied with matched rolls for grooving 4–12-inch/114.3–323.9-mm carbon steel pipe to Original Groove System (OGS) specifications and 14–24-inch/355.6–610-mm carbon steel pipe to Advanced Groove System (AGS) specifications.

VE460 rolls are marked with the size and part number, and are color coded to identify the pipe material. For roll grooving to other specifications and materials, refer to the tables on page 60. Grooving tools for other specifications, sizes, and materials must be purchased separately.

CAUTION

- This tool must be used **ONLY** for grooving pipe with specifications that fall within the designated parameters.
- Verify that the upper and lower grooving rolls are a matched set.

Failure to follow these instructions could damage the tool and cause product failure, resulting in property damage or personal injury.

RECEIVING THE TOOL

VE460 tools are palletized individually and enclosed in a wooden or cardboard sleeve. The stabilizer assembly and additional roll sets are shipped in a separate container. Save the original packaging for return shipment of rental tools.

Upon receipt of the tool, ensure that all necessary parts are included. If any parts are missing, contact Victaulic.

LARGE CONTAINER CONTENTS

Qty.	Description
1	VE460 Pipe Roll Grooving Tool
1	Roll Set for 8–12-inch/219.1–323.9-mm Steel Pipe Mounted on the Tool (Unless Ordered Otherwise) - Original Groove System Specifications
1	Stabilizer Mounting Hardware (Installed Loose in Mounting Holes for Stabilizer)
1	Pipe Diameter Tape
1	Hydraulic System Bleeder Tube
1	Safety Foot Switch with Detachable Line Cord
2	TM-VE460 Operating and Maintenance Instructions Manual
2	RP-VE460 Repair Parts List

SMALL CONTAINER CONTENTS

Qty.	Description
1	Stabilizer Assembly
1	Roll Set for 4–6-inch/114.3–168.3-mm Steel Pipe - Original Groove System Specifications
1	Roll Set for 14–24-inch/355.6–610-mm Steel Pipe - AGS Specifications

NOTE: Support bases for grooving 26-inch/660.0-mm and larger pipe sizes shall be ordered separately and will be shipped in separate containers from the tool components listed on this page.

TOOL RETURN OR DISPOSAL

Prepare tool for shipment as received. Ensure that chips and debris are thoroughly cleaned from the machine, all fluids are drained, and power is disconnected. VE460 tool, drained fluids, and accessories shall be disposed of or recycled according to local ordinances. Contact Victaulic with questions.

POWER REQUIREMENTS

DANGER

- **ONLY QUALIFIED ELECTRICIANS SHOULD CONNECT INCOMING POWER TO THE TOOL.**

- **To reduce the risk of electric shock, check the electrical source for proper grounding.**
- **Always turn off the main power supply to the tool before making any tool adjustments or before performing any maintenance.**
- **DO NOT alter the plug in any way.**

Failure to follow these instructions could result in death or serious personal injury.

THE VE460 IS DESIGNED FOR USE ON A TYPE TN POWER DISTRIBUTION SYSTEM AND CAN OPERATE UNDER THE FOLLOWING CONDITIONS:

Volts	Phase	Hertz	Full-Load Current
230	3	50/60	18.3 AMPS
380	3	50/60	9.9 AMPS
415	3	50/60	9.1 AMPS
460	3	50/60	8.2 AMPS

Short circuit interrupting capacity is 5,000 AMPS.

The tool is shipped with the wiring set for 220-volt operation, unless specified otherwise on the order. To re-wire the tool for 440-volt service, the following conversions shall be made. Refer to the electrical schematic in the RP-VE460 Repair Parts List and the information contained on the nameplate on the tool's drive motor and hydraulic pump motor.

Conversions to 440-volt, 60-Hz service include:

1. Motor Connections
2. Thermal Overload Unit Changes

The circuit protection required for 220-volt operation is 45 amps. For 440-volt operation, 25-amp circuit protection is required.

All VE460 components are grounded to the frame of the tool. Ensure that the frame is grounded properly.

For other voltages and frequencies, contact Victaulic.

POWER HOOKUP

Each VE460 Roll Grooving Tool is provided with a label outside the main electrical enclosure, which identifies voltage ratings for the tool (refer to example below). Reference shall be made to this label to ensure proper tool setup.

VE460

SERIAL NO.

DATE MFD.

VOLTS	PHASE	HERTZ	FULL-LOAD CURRENT
230	3	50/60	18.3 AMPS
380	3	50/60	9.9 AMPS
415	3	50/60	9.1 AMPS
460	3	50/60	8.2 AMPS

DRIVE MOTOR:

VOLTS	PHASE	HERTZ	FULL-LOAD CURRENT
230	3	50/60	12.6 AMPS
380	3	50/60	7.6 AMPS
415	3	50/60	7.0 AMPS
460	3	50/60	6.3 AMPS

SHORT CIRCUIT INTERRUPTING CAPACITY 5,000 AMPS

- GEAR OIL – AGMA 7
- HYDRAULIC OIL – HIGH-PRESSURE, ANTI-WEAR ISO GRADE 32
- BEARING LUBE – ANTI-WEAR, EXTREME PRESSURE NLGI GRADE 2

ELECTRICAL ASSEMBLY DWG. 1E-301-460-1MCH REVISION LEVEL

Victaulic Company World Headquarters
 4901 Kesslersville Road • Easton, PA 18040
 victaulic.com

Manufactured in Canada

The VE460 Roll Grooving Tool is supplied with a ¾-inch nominal conduit opening for wiring incoming power. The conduit opening is located at the back of the tool near the main electrical enclosure.

Incoming electrical connections shall be made inside the main electrical enclosure. The incoming, three-phase power shall be connected at the top of the main breaker at the upper-right side within the main electrical enclosure.

1. Make the ground connection inside the main electrical enclosure.
2. Make 3-phase electrical connections to the circuit breaker of the tool.
3. After power is connected, the tool shall be checked for proper rotational direction.

TOOL NOMENCLATURE

NOTICE

- Drawings and/or pictures in this manual may be exaggerated for clarity.
- The tool, along with this operating and maintenance instructions manual, contains trademarks, copyrights, and/or patented features that are the exclusive property of Victaulic.

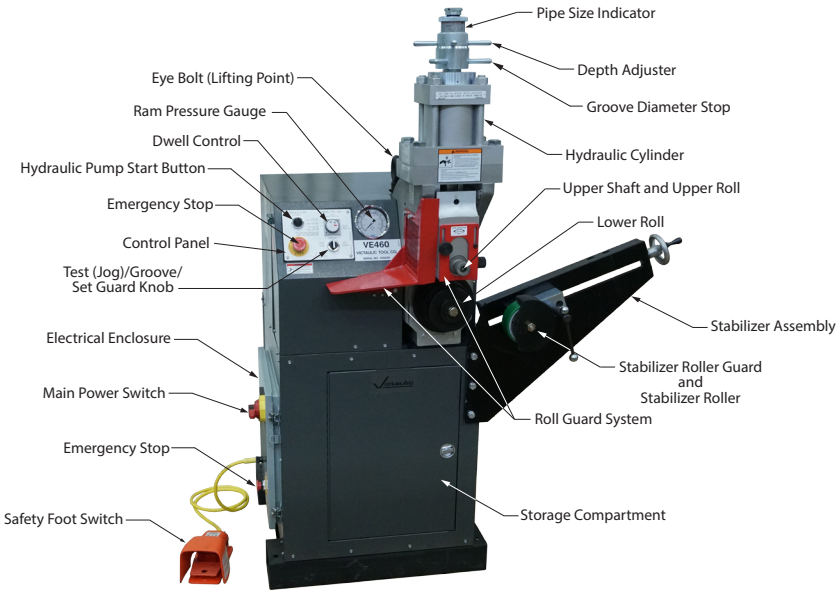

Located Under Control Panel

⚠ DANGER	
	<p>Contact with hazardous voltage inside this cover plate may result in death or serious personal injury.</p> <ul style="list-style-type: none"> • ALWAYS disconnect the tool from the power source before performing maintenance or adjustments. • Only qualified personnel should open this cover plate.
	<p>3308 Rev. B R095424LE</p>

Located on Electrical Enclosure

⚠ DANGER	
	<p>Contact with hazardous voltage inside this door may result in death or serious personal injury.</p> <ul style="list-style-type: none"> • ALWAYS disconnect the tool from the power source before performing maintenance or adjustments. • Only qualified personnel should open this door.
	<p>3308 Rev. B R095424LE</p>

Located on Front of Tool

⚠ WARNING	
	<p>Grooving rolls can crush or cut fingers and hands.</p> <ul style="list-style-type: none"> • Always disconnect the tool from the power source before making any tool adjustments. • Loading/unloading pipe will place your hands close to the rollers. Keep hands away from the grooving rolls and the roller on the pipe stabilizer during operation.
	<ul style="list-style-type: none"> • Never reach inside the pipe ends or across the tool or pipe during operation. • Always groove pipe in a CLOCKWISE direction. • Never groove pipe that is shorter than the recommended lengths listed in the operating and maintenance manual. • Never wear loose clothing, loose gloves, or anything that can become entangled in moving parts. <p>3307 Rev. C R091024LE</p>

⚠ WARNING	
	<p>Failure to follow instructions and warnings could result in serious personal injury, property damage, and/or product damage.</p> <ul style="list-style-type: none"> • Before operating or servicing any pipe preparation tools, read all instructions in the Operating and Maintenance Instructions Manual and all labels on the tool. • Wear safety glasses, hardhat, foot protection, and hearing protection when working around tools.
	<p>If you need additional copies of any literature, or if you have questions concerning the safe and proper operation of any pipe preparation tools, contact Victaulic, P.O. Box 31, Easton, PA 18044-0031, Phone: 1-800-PICK-VIC, E-Mail: pickvic@victaulic.com.</p> <p>3307 Rev. B R091024LE</p>

IMPORTANT INFORMATION FOR TOOL SETUP

Support bases are required when using a VE460 Roll Grooving Tool to groove 26-inch/660-mm and larger pipe sizes. Each support base corresponds with a range of pipe sizes; these requirements shall be followed to ensure pipe is grooved properly (refer to table below).

If the tool will be used for roll grooving 24-inch/610-mm and smaller pipe sizes, follow the “Tool Setup for Grooving 24-inch/610-mm and Smaller Pipe Sizes” section. For the 24-inch/610-mm and smaller pipe size range, support bases are not required, but the tool shall be anchored to a sturdy, level concrete floor.

If the tool will be used for roll grooving 26-inch/660-mm and larger pipe sizes, follow the “Tool Setup for Grooving 26-inch/660-mm and Larger Pipe Sizes” section. **NOTE:** Each support base is 12 inches/305 mm in height and weighs approximately 180 pounds/82 kilograms.

WARNING

- The tool or bottom support base **SHALL** always be anchored to a sturdy, level concrete floor that is capable of handling the weight of the tool and accessories.
- Handrails shall be installed and the electrical cord/safety foot switch cord shall be routed through the support base(s) to prevent tripping hazards.

Failure to follow this instruction could result in property damage or serious personal injury.

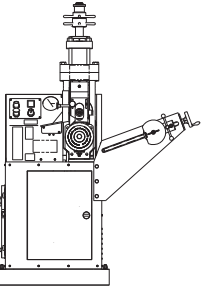
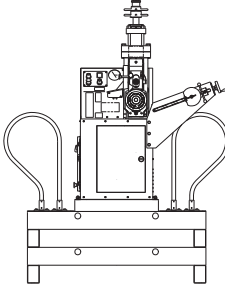
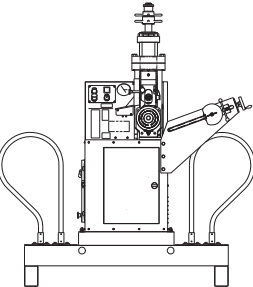
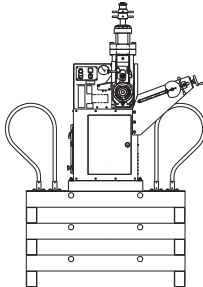
Configuration	Pipe Size Range	Configuration	Pipe Size Range
 <p>Tool without support base(s)</p>	24-inch/610-mm and Smaller Pipe Sizes	 <p>Tool installed with two support bases</p>	40–50-inch/ 1016–1270-mm Pipe Sizes
 <p>Tool installed with one support base</p>	26–38-inch/ 660–965-mm Pipe Sizes	 <p>Tool installed with three support bases</p>	52–60-inch/ 1320–1524-mm Pipe Sizes

TOOL DIMENSIONS AND SPECIFICATIONS – WITHOUT SUPPORT BASES

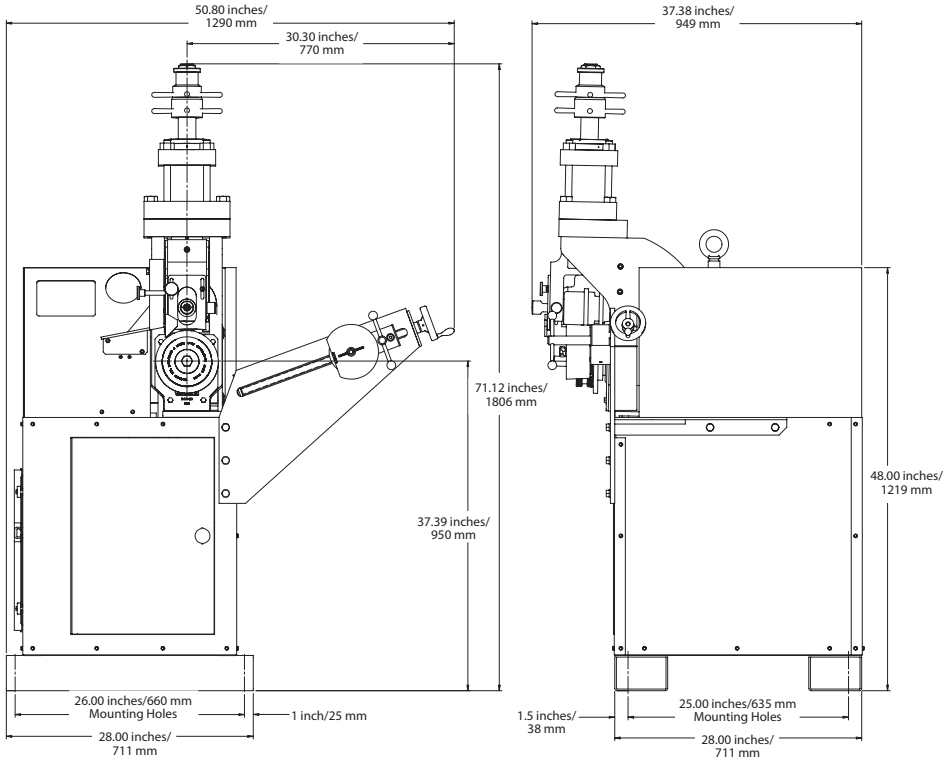

TOOL DIMENSIONS AND SPECIFICATIONS – WITH SUPPORT BASES

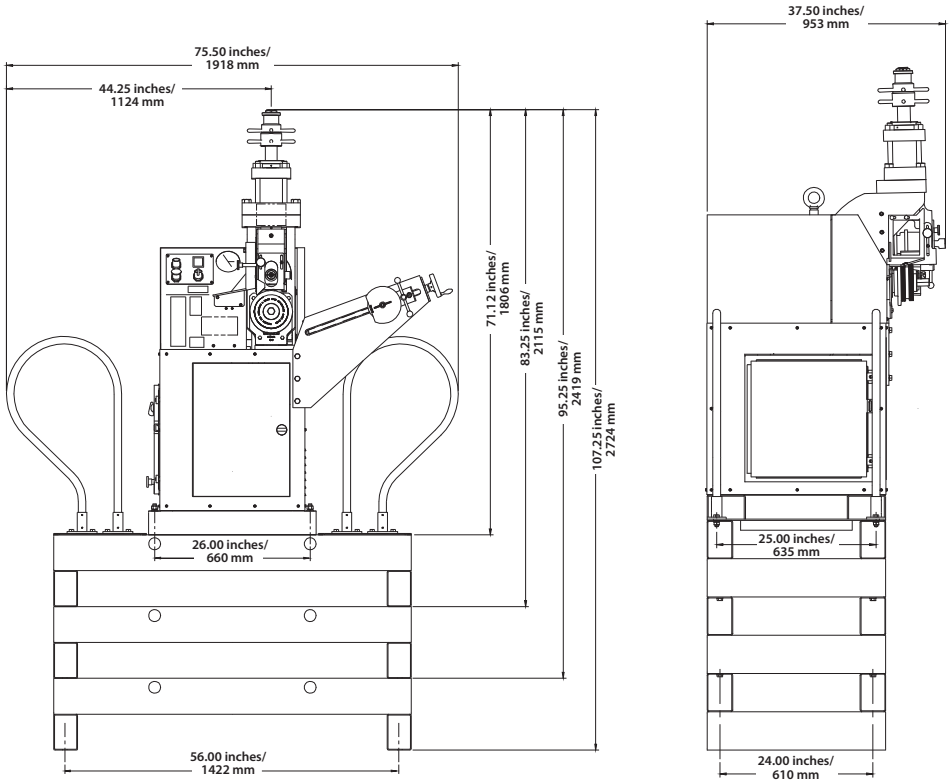

The VE460 Roll Grooving Tool by itself weighs approximately 1800 pounds/820 kilograms.

- The VE460 Roll Grooving Tool mounted on one support base weighs approximately 1980 pounds/900 kilograms.
- The VE460 Roll Grooving Tool mounted on two support bases weighs approximately 2160 pounds/980 kilograms.
- The VE460 Roll Grooving Tool mounted on three support bases weighs approximately 2340 pounds/1065 kilograms.

Tool sound pressure is below 70 dB(A).

LIFTING REQUIREMENTS – WITHOUT SUPPORT BASES

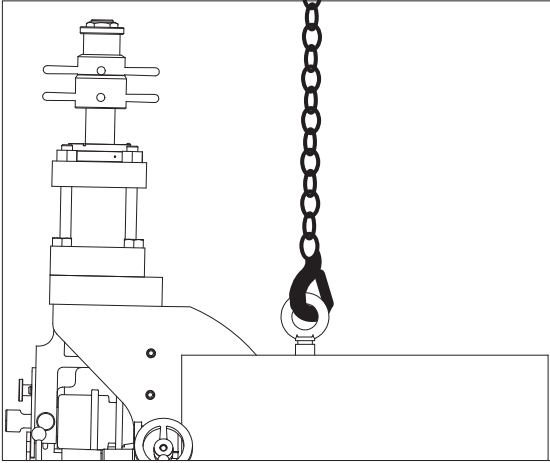

⚠ WARNING

- An overhead crane shall be used to lift/transport the tool to its intended location.
- An eye bolt is provided in the top-middle section of the tool, as shown in the drawing to the left.
- Minimum capacity rating of the overhead crane shall be 2000 pounds/910 kilograms.

Failure to follow this instruction could result in property damage or serious personal injury.

LIFTING REQUIREMENTS – WITH SUPPORT BASES

WARNING

- DO NOT attempt to use the eye bolt for lifting a VE460 Roll Grooving Tool that is installed on a support base(s).
- When attempting to relocate a VE460 Roll Grooving Tool that is installed on a support base(s), the wedge-type concrete floor anchors shall be removed, and a forklift shall be used to transport the tool assembly.
- The forks of the forklift shall engage only with the top support base, as shown in the drawing below.
- Wedge-type concrete floor anchors shall be used to anchor the tool/support base assembly to the floor at the new location. Refer to the “Tool Setup for Grooving 26-inch/660-mm and Larger Pipe Sizes” section.

Failure to follow these instructions could result in property damage or serious personal injury.

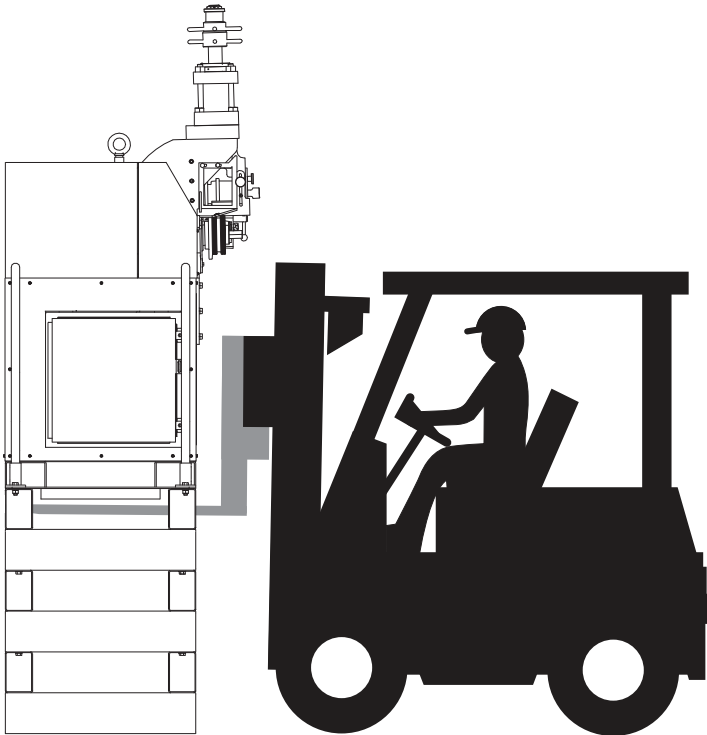

TOOL SETUP

24-INCH/610-MM AND SMALLER PIPE

WARNING

- **DO NOT** turn on the main power supply to the tool until instructed otherwise.
- The tool **SHALL** be leveled and anchored securely on a concrete floor or base.

Failure to follow these instructions could result in serious personal injury.

1. Remove all components from the packaging, and ensure that all necessary items are included. Refer to the “Receiving the Tool” section.
2. Select a location for the tool and pipe stand by taking into consideration the following factors:
 - a. The required power supply (refer to the “Power Requirements” section)
 - b. Ambient temperature requirements of 20° F to 104° F / -6°C to 40° C and ambient humidity requirements of 30 to 85% RH non-condensing.
 - c. A level concrete floor for the tool/support base(s) and pipe stand
 - d. Adequate space to handle pipe lengths
 - e. Adequate clearance around the tool/ support base(s) for adjustment and maintenance
 - f. Adequate stability and distance from other machinery, free from excessive vibration and impact.
 - g. Proper lighting and protection from rain, snow, and environmental contaminants.
 - h. Electrical Panel disconnect and Emergency Stop buttons must be accessible at all times.

NOTE: An overhead crane shall be used to lift/ transport the tool to its intended location. An eye bolt is provided in the top-middle section of the tool. Ensure that the minimum capacity rating of the overhead crane is 2000 pounds/910 kilograms. Refer to the “Tool Dimensions and Weight – Without Support Bases” section for additional information.



3. The VE460 Roll Grooving Tool is designed for use in a permanent location and shall be located on a level concrete floor or base. After an appropriate location is chosen, the tool shall be leveled front-to-back and side-to-side and anchored securely. A non-level tool can severely affect grooving operation. When checking tool level, place the level directly on the tool surfaces, as shown above.

WARNING

- **During tool setup, two people are needed to safely handle the stabilizer assembly due to its weight.**
- **An alternative is to use a hoist to lift the stabilizer assembly into position.**

Failure to follow these instructions could result in serious personal injury.

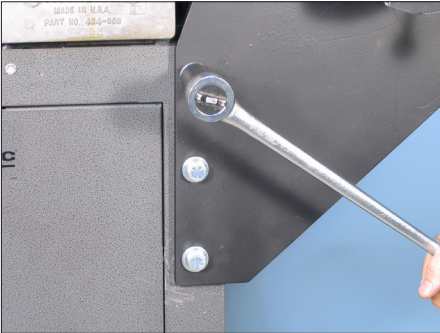
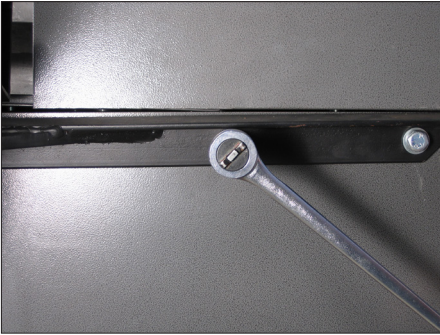

4. Remove the stabilizer bolts and lock washers from the front and right side of the tool. Position the stabilizer assembly onto the front, right corner of the tool so that the mounting holes in the stabilizer assembly align with the mounting holes in the tool. Using the stabilizer bolts and lock washers, removed previously from the tool, fasten the stabilizer assembly to the tool.

NOTE: The tool frame is designed so that no nuts are required on the ends of the bolts. Tighten all stabilizer bolts completely until the lock washers are compressed fully.

NOTICE

- VE460 tools are equipped with a detachable safety foot switch cord. The safety foot switch can be removed easily for storage in the cabinet when the tool is not in use.



5. Install the safety foot switch by aligning the pins/tab of the male adapter plug with the receptacle.



6. Tighten the locking ring on the plug.

7. Proceed to the "Power Requirements" section.

26-INCH/660-MM AND LARGER PIPE

⚠ WARNING

- **DO NOT** turn on the main power supply to the tool until instructed otherwise.
- The bottom support base **SHALL** always be anchored to a sturdy, level concrete floor that is capable of handling the weight of the tool and accessories.

Failure to follow these instructions could result in serious personal injury.

1. Remove all components from the packaging, and ensure that all necessary items are included. Refer to the “Receiving the Tool” section.

2. The VE460 Roll Grooving Tool with support base(s) is designed for use in a permanent location and shall be located on a level concrete floor. After an appropriate location is chosen, the bottom support base shall be level and securely anchored. A non-level tool can severely affect grooving operation.

3. Select a location for the tool/support base(s) and pipe stand by taking into consideration the following factors:

- a. The required power supply (refer to the “Power Requirements” section)
- b. Ambient temperature requirements of 20° F to 104° F / -6° C to 40° C and ambient humidity requirements of 30 to 85% RH non-condensing.
- c. A level concrete floor for the tool/support base(s) and pipe stand
- d. Adequate space to handle pipe lengths
- e. Adequate clearance around the tool/support base(s) for adjustment and maintenance
- f. Adequate stability and distance from other machinery, free from excessive vibration and impact.
- g. Proper lighting and protection from rain, snow, and environmental contaminants.
- h. Electrical Panel disconnect and Emergency Stop buttons must be accessible at all times.

⚠ WARNING

- During tool setup, two people are needed to safely handle the stabilizer assembly due to its weight.
- An alternative is to use a hoist to lift the stabilizer assembly into position.

Failure to follow these instructions could result in serious personal injury.

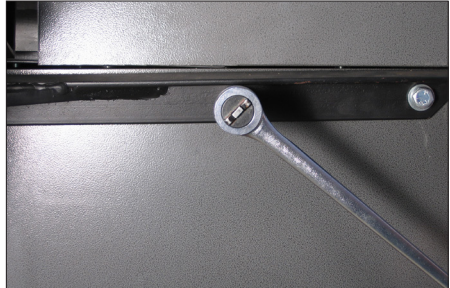

4. Remove the stabilizer bolts and lock washers from the front and right side of the tool. Position the stabilizer assembly onto the front, right corner of the tool so that the mounting holes in the stabilizer assembly align with the mounting holes in the tool. Using the stabilizer bolts and lock washers, removed previously from the tool, fasten the stabilizer assembly to the tool.

NOTE: The tool frame is designed so that no nuts are required on the ends of the bolts. Tighten all stabilizer bolts completely until the lock washers are compressed.

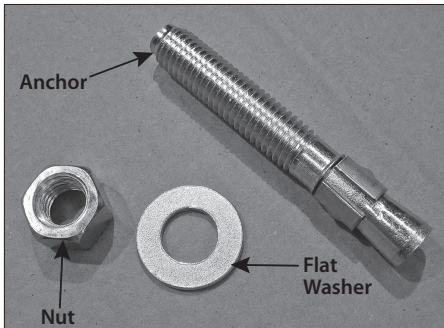
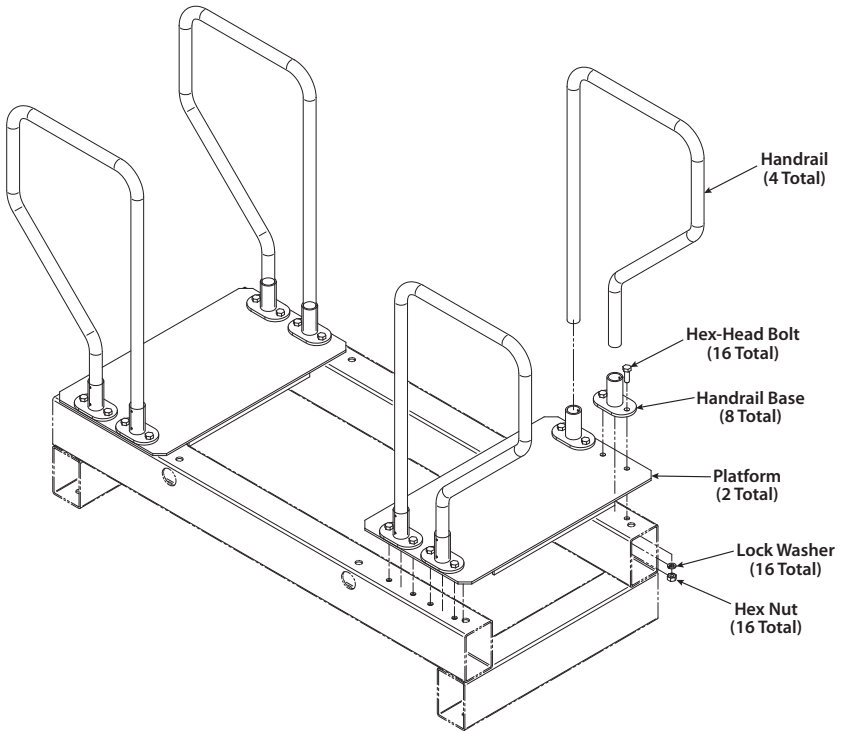

5. Wedge-type concrete floor anchors ($\frac{5}{8}$ x $4\frac{1}{4}$ -inch size) shall be used to secure the bottom platform to the floor. Ensure that the floor anchors are installed into the concrete floor in accordance with the manufacturer's instructions.



6. Using a four-point lifting method, as shown above, raise the bottom support base over the area where the floor anchors are installed. Align the four holes in the support base with the four floor anchors. Slowly lower the support base over the floor anchors.

NOTE: DO NOT attempt to move the support base with a forklift.



7. Install a flat washer and nut onto each of the floor anchors, as shown. Tighten the nut completely.



8. At this time, an additional support base can be installed. Following the same four-point lifting method as shown in step 6, raise the second support base over the first support base. Align the four holes in the second support base with the four holes in the first support base. Slowly lower the second support base onto the first support base.

9. Locate the bolt, two flat washers, lock washer, and nut (supplied with the support base kit). This hardware is required to anchor the support bases to each other.

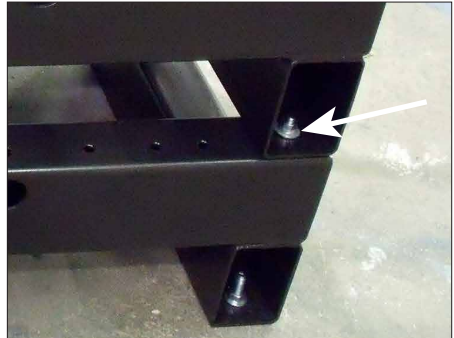

10. Insert a bolt with flat washer through the holes in the second support base and first support base. Apply a flat washer, lock washer, and nut to the end of the bolt. Tighten the nut completely until the lock washer is compressed. Repeat this step for the other three hole locations.

11. If a third support base is required, repeat steps 8–10.



12. When the correct number of support bases are installed and secured, the tool shall be lifted into position and placed onto the support base(s). An eye bolt is provided in the top-middle section of the tool. Ensure that the minimum capacity rating of the overhead crane is 2000 pounds/910 kilograms. Refer to the “Tool Dimensions and Weights – Without Support Bases” section for additional information.

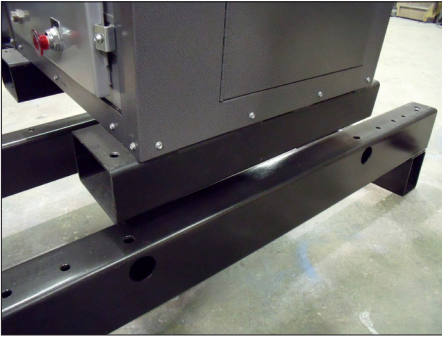

13. As the tool is being lowered onto the support base(s), ensure that the power cord is guided out of the way and the safety foot switch cord is disconnected to prevent damage. The holes in the base of the tool shall align with the innermost holes in the support base, as shown.

14. Locate the bolt, two flat washers, lock washer, and nut (supplied with the support base kit). This hardware is required to anchor the tool and support base to each other.



15. Insert a bolt with a flat washer up through the hole in the support base and into the hole in the base of the tool. Apply a flat washer, lock washer, and nut to the end of the bolt. Tighten the nut completely until the lock washer is compressed. Repeat this step for the other three hole locations in the support base and tool base.

NOTICE

- VE460 tools are equipped with a detachable safety foot switch cord. The safety foot switch can be removed easily for storage in the cabinet when the tool is not in use.

⚠ WARNING

- Handrails shall be installed and the electrical cord/safety foot switch cord shall be routed through the support base(s) to prevent tripping hazards.

Failure to follow this instruction could result in serious personal injury.



16. Route the safety foot switch cord up through the support base(s). Plug the safety foot switch cord into the receptacle on the side of the tool by aligning the pins/tab of the male adapter plug with the receptacle. Tighten the locking ring on the plug.

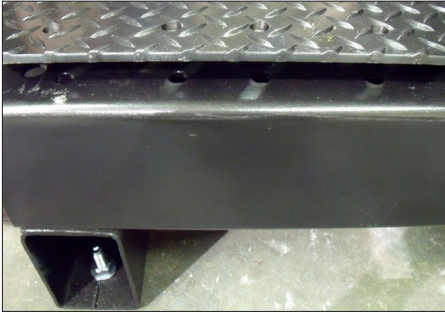

17. Install the platform onto the support base. Align the holes in the platform with the holes in the support base, as shown. Repeat this step for the other side of the tool.

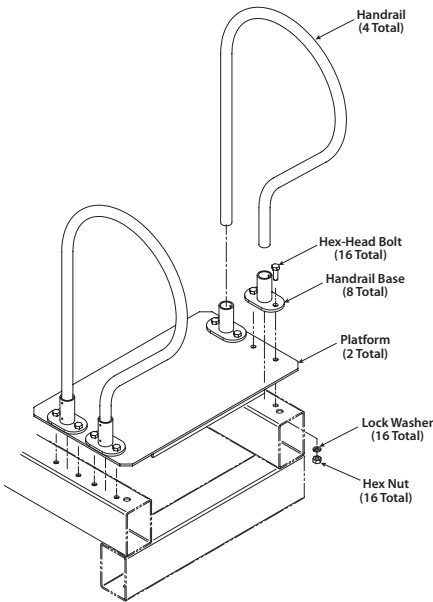

18. Locate the hex-head bolt, lock washer, and hex nut (supplied with the support base kit). This hardware is required for installation of the handrail bases.

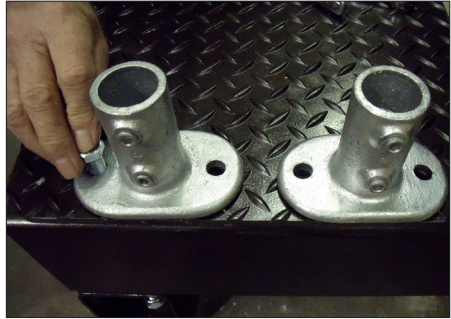

19a. Install a handrail base onto the platform at the eight locations on the platform/tool support. Ensure that the holes in the handrail bases align with the holes in the platforms/support base and that the set screws on the handrail bases face away from the platform, as shown.

19b. Install a hex-head bolt through the two holes in each handrail base and into the platform/tool support. Apply a lock washer and hex nut onto the end of each hex-head bolt.



19c. Tighten the hex nut completely until the lock washer is compressed. Repeat this step for each handrail base location.



19d. Insert a handrail into each handrail base, as shown.

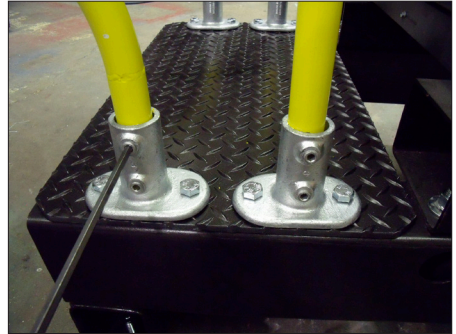

19e. Tighten the two set screws on each handrail base to retain the handrails.

20. Proceed to the “Power Requirements” section.

NOTICE

- **Always use the handrails for support when climbing the support base(s).**
- **When attempting to relocate a tool that is installed on support base(s), refer to the “Tool Dimensions and Weights – With Support Bases” and “Lifting Requirements – With Support Bases” sections for additional information.**

VERIFICATION OF PIPE ROTATION DIRECTION

The VE460 Roll Grooving Tool is equipped with a “TEST (JOG)” setting. Operating the tool in the “TEST (JOG)” setting allows for:

- Determining rotation of the tool’s lower roll
- Confirming that the pipe to be grooved is tracking properly on the lower roll



1. Turn the main power switch on the side of the tool to the “ON” position.



2. Pull the “EMERGENCY STOP” button on the control panel and the electrical enclosure to the out position.



3. Place the selector switch on the control panel to the “TEST (JOG)” mode and momentarily depress the “HYDRAULIC PUMP START” button to energize the lower roll. Observe lower roll rotational direction. Release the “HYDRAULIC PUMP START” button to de-energize the lower roll.

NOTE: The safety foot switch does not need to be depressed while the tool is in the “TEST (JOG)” mode.

4. Proper rotation of the lower roll is **clockwise** when viewed from the front of the tool. If rotation is clockwise, power hookup is complete.

⚠ WARNING

- Always turn off the main power supply to the tool before making any tool adjustments.

Failure to follow this instruction could result in serious personal injury.



5. If rotation of the lower roll is counter-clockwise, turn the main power switch on the side of the tool to the “OFF” position and proceed with the following steps.



6. Turn off the main power supply to the tool (circuit breaker panel, knife switch, etc.). Lock the switch in the “OFF” position to prevent accidental engagement.

NOTE: Victaulic does not supply this lockout mechanism.



7. Open the main enclosure by loosening the screw on the two brackets of the main enclosure. Push in the lever at the bottom of the handle while turning clockwise to open the main enclosure. Reverse any of the two incoming lines at the top of the main power disconnect (located at the upper-right side within the enclosure).

8. Close the main enclosure and re-tighten the screw on the two brackets.

9. Turn on the main power supply to the tool (circuit breaker panel, knife switch, etc.).

10. Follow steps 1–4 to check the rotational direction of the lower roll. If rotational direction is not clockwise, contact Victaulic. If rotational direction is clockwise, the verification procedure is complete.

EMERGENCY STOP OPERATION

Verify that emergency stop function is operational during tool setup. Perform the “PUSH”, “PULL”, and “START” actions to test emergency stop function.



1. Turn the main power switch on the side of the tool to the “ON” position.

WARNING

- The motor must not energize until after the “HYDRAULIC PUMP START” button has been pressed.
- If the motor energizes from a cold start without first pressing the “HYDRAULIC PUMP START” button, discontinue use and contact Victaulic.

Failure to follow this instruction could result in serious personal injury.



2. Press the “HYDRAULIC PUMP START” button.



3. Depress the safety foot switch, confirm tool operation, then release the safety foot switch.

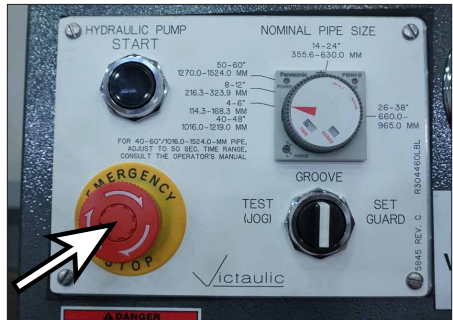

4. Push the “EMERGENCY STOP” button and confirm that this action has cut power to the motor. Depressing the footswitch, pressing the start button, or adjusting the selector switch should have no effect on the state of the tool. All components should remain off.

WARNING

- The motor must not energize while the “EMERGENCY STOP” button is activated.
- If the motor can be energized while the “EMERGENCY STOP” button is activated, discontinue use and contact Victaulic.

Failure to follow this instruction could result in serious personal injury.



5. Pull the “EMERGENCY STOP” button and confirm that power to the motor remains off. Depressing the foot switch or adjusting the selector switch should have no effect on the state of the tool. All components should remain off.

! WARNING

- The motor must not re-energize until after the “HYDRAULIC PUMP START” button has been pressed.
- If the motor energizes after an emergency stop without first pressing the “HYDRAULIC PUMP START” button, discontinue use and contact Victaulic.

Failure to follow this instruction could result in serious personal injury.



6. Press the “HYDRAULIC PUMP START” button.



7. Depress the safety foot switch, confirm tool operation, then release the safety foot switch.



8a. Turn the selector switch to the “GROOVE” position. The tool head should lower when the footswitch is depressed, and rise to its resting position when the footswitch is released.



8b. Turn the selector switch to the “TEST (JOG)” position. The tool head should lower when the footswitch is depressed, and remain in position when the footswitch is released.

8c. Turning the selector switch from “TEST (JOG)” to “GROOVE” with the head in a lowered position should cause the head to rise to its resting position.

9. If the tool does not function as described, refer to the “Troubleshooting” section.

PREPARING PIPE FOR GROOVING

CAUTION

- For maximum grooving roll life, remove foreign material and loose rust from the interior and exterior surfaces of the pipe ends. Rust is an abrasive material that will wear the surface of grooving rolls.

Foreign material may interfere with or damage grooving rolls, resulting in distorted grooves or grooves that are out of Victaulic specifications.

For proper tool operation and production of grooves that are within Victaulic specifications, the following pipe preparation steps shall be followed.

Victaulic recommends square-cut pipe for use with grooved-end pipe products. Square-cut pipe SHALL be used with Victaulic FlushSeal® and EndSeal® gaskets. For 12-inch/323.9-mm and smaller pipe sizes, beveled-end pipe may be used with Victaulic standard and Vic-Flange gaskets, provided that the wall thickness is standard wall (ANSI B36.10) or less and that the bevel meets ANSI B16.25 (37½°) or ASTM A-53 (30°). **NOTE:** Roll grooving beveled-end pipe may result in unacceptable pipe flare. Beveled steel pipe in 14–60-inch/355.6–1524-mm sizes is acceptable with Victaulic Advanced Grooving System (AGS) standard or FlushSeal gaskets, including AGS Vic-Flanges.

- 1a.** For 12-inch/323.9-mm and smaller pipe sizes, raised internal and external weld beads and seams shall be ground flush with the pipe surface 2 inches/50 mm back from the pipe ends.
- 1b.** For 14–38-inch/355.6–965-mm pipe sizes, raised internal and external weld beads and seams shall be ground flush with the pipe surface 4 inches/100 mm back from the pipe ends.
- 1c.** For 40–60-inch/1016–1524-mm pipe sizes, raised internal and external weld beads and seams shall be ground flush with the pipe surface 4½ inches/115 mm back from the pipe ends.

- 2.** The inside diameter of the pipe end shall be cleaned to remove coarse scale, dirt, and other foreign material that might interfere with or damage grooving rolls. The front edge of the pipe end shall be uniform with no concave/convex surface features that will cause improper grooving roll tracking and result in difficulties during coupling assembly.

PIPE LENGTH REQUIREMENTS

VE460 tools are capable of grooving short pipe lengths without the use of a pipe stand. Table 1 identifies the minimum pipe lengths that can be grooved safely by using Victaulic Grooving Tools. In addition, this table identifies the maximum pipe lengths that can be grooved without the use of a pipe stand. Refer to the “Grooving Short Pipe Lengths” section for instructions on how to groove short pipe lengths. **NOTE:** Grooved pipe nipples, shorter than those listed in Table 1, are available from Victaulic.

Pipe lengths, longer than those listed in Table 1 (and up to 20 feet/6 meters), shall be supported with a pipe stand. Pipe lengths, from 20 feet/6 meters up to double-random lengths (approximately 40 feet/12 meters), shall be supported with two pipe stands. Refer to the “Long Pipe Lengths” section for instructions on how to groove long pipe lengths.

If pipe is required that is shorter than the minimum length listed in Table 1, shorten the next-to-last piece so that the last piece is as long (or longer) than the minimum length specified.

EXAMPLE: A 20-foot, 4-inch/6.2-m length of 10-inch diameter steel pipe is required to finish a section, and only 20-foot/6.1-m lengths are available. Instead of roll grooving a 20-foot/6.1-m length of carbon steel pipe and a 4-inch/102-mm length of carbon steel pipe, follow these steps:

1. Refer to Table 1, and note that for 10-inch diameter carbon steel pipe, the minimum length that should be roll grooved is 10 inches/255 mm.
2. Roll groove a 19-foot, 6-inch/5.9-m length of pipe and a 10-inch/255-mm length of pipe. Refer to the “Long Pipe Lengths” section.

TABLE 1- PIPE LENGTHS SUITABLE FOR GROOVING

Steel, Stainless Steel, Aluminum, and PVC Pipe Size	Length – inches/mm	
Nominal Pipe Size inches/mm	Minimum	Maximum
4 100	8 205	36 915
5 125	8 205	32 815
6 150	10 255	28 715
8 200	10 255	24 610
10 250	10 255	20 510
12 300	12 305	18 460
14 350	12 305	16 410
16 400	12 305	16 410
18 – 60 450 - 1500	<p>NOTE: Always use a pipe stand when roll grooving pipe in these sizes. DO NOT roll groove pipe lengths shorter than 18 inches/457 mm in these sizes.</p>	

CHECKING AND ADJUSTING THE TOOL PRIOR TO GROOVING

Every Victaulic roll grooving tool is checked, adjusted, and tested at the factory prior to shipment. However, before attempting to operate the tool, the following checks and adjustments should be made to ensure proper tool operation.

! WARNING

- Always turn off the main power supply to the tool before making any tool adjustments.

Failure to follow this instruction could result in serious personal injury.

GROOVING ROLLS

Ensure that the proper roll set is installed on the tool for the pipe size and material that will be grooved. Roll sets are marked with the pipe size, part number, and they are color coded for the pipe material. Refer to the tables on pages 61 – 62. If the proper rolls are not installed on the tool, refer to the “Roll Changing” section.

! CAUTION

- Ensure that the lower-roll retaining bolt is tight and that the upper shaft is locked in position.

A loose lower-roll retaining bolt or upper shaft could cause damage to the tool and rolls.

ADJUSTING THE ROLL GUARDS

! CAUTION

- The “Adjusting the Roll Guards” section shall be completed with every roll change.
- Verify that the upper and lower grooving rolls are a matched set and are properly lubricated.

Failure to follow these instructions could result in property damage or personal injury.

The VE460 tool features a “SET GUARD” control switch setting. With the correct pipe size and schedule inserted in the tool, the “SET GUARD” setting allows the operator to complete the necessary guard adjustments.



1. Retract the depth adjusters to allow for full travel of the hydraulic cylinder.



2. Loosen the knob on the front of the roll guards to raise the plate to its highest position. Tighten the knob.



3. Insert a length of pipe that is the correct size and schedule over the lower roll. Ensure that the pipe end contacts the lower-roll backstop flange. The pipe shall rest directly on top of the roll and shall not be skewed to one side or the other.



4. Place the switch on the control panel to the “SET GUARD” mode. Depress the safety foot switch to place the tool’s hydraulic system under pressure. Movement of the tool’s ram/ slide/upper roll will occur. The hydraulic pump will shut off automatically when the upper roll contacts the pipe and an increase in hydraulic system pressure (as little as 75–100-psi pressure) occurs. Release the safety foot switch. The ram assembly will remain down. If hydraulic pressure is not established, the ram will return to the neutral position as the safety foot switch is released.



5. Prior to making tool guard adjustments, push the “EMERGENCY STOP” button on the control panel. The upper roll will continue to remain seated against the pipe.

6. Two guard setting pads are included with the tool. For 12-inch/323.9-mm and smaller pipe sizes, use the ¼-inch/6.4-mm thick guard setting pad. For 14-inch/355.6-mm and larger pipe being grooved with AGS roll sets, use the ⅜-inch/9.5-mm thick guard setting pad containing a “FOR AGS ONLY” label.

⚠ WARNING

- The roll guards shall be spaced properly by using the appropriate guard setting pad.

Failure to follow this instruction could result in serious personal injury.

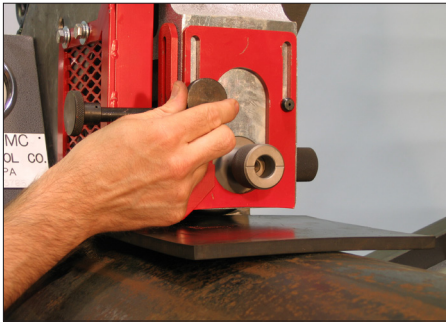

7. Hold the correct guard setting pad firmly against the pipe and push it under the roll guards. Loosen the knob on the front of the roll guards to drop the plate onto the guard setting pad. Tighten the knob.



8. Loosen the knob on the left side of the roll guards to drop the side sliding guard onto the guard setting pad. Tighten the knob.

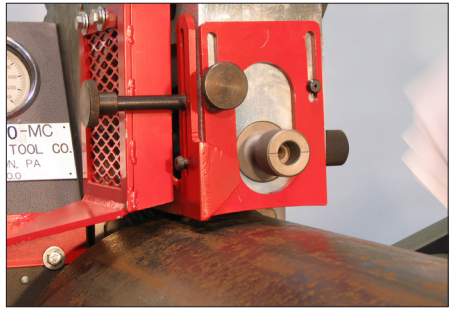

9. Remove the guard setting pad from the pipe. Store the guard setting pad in a safe location.



10. When tool guard adjustments are complete, pull the "EMERGENCY STOP" button on the control panel to the out position.

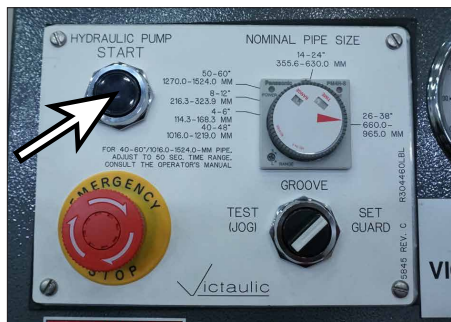

11. Depress and release the "HYDRAULIC PUMP START" button. The tool's hydraulic pump motor will energize and the tool's ram shaft will retract to the neutral position.

12. The guard setting procedure is complete.

PIPE STABILIZER ADJUSTMENT

⚠ WARNING

- Always turn off the main power supply to the tool before making any tool adjustments.**
- DO NOT reach over pipe while making adjustments.**
- DO NOT make adjustments while the tool/pipe is in operation/motion.**

Failure to follow these instructions could result in serious personal injury.

The pipe stabilizer for the VE460 is designed to prevent pipe sway of short and long pipe lengths. When the stabilizer is adjusted for a selected pipe size and wall thickness, it does not require further adjustment unless pipe of a different size and wall thickness will be grooved. Pipe of the same size and wall thickness can be moved in and out of the tool without retracting the stabilizer.

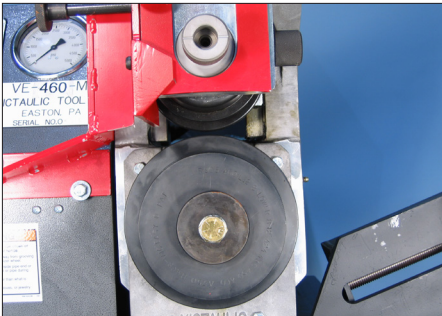

1. Ensure that the proper roll set is installed on the tool for the pipe size and material to be grooved. Rolls are marked with the pipe size, part number, and they are color-coded according to the pipe material. Refer to the tables on pages 61 – 62.

2a. Loosen the stabilizer locking handle and the stabilizer-roller-guard wing nut.

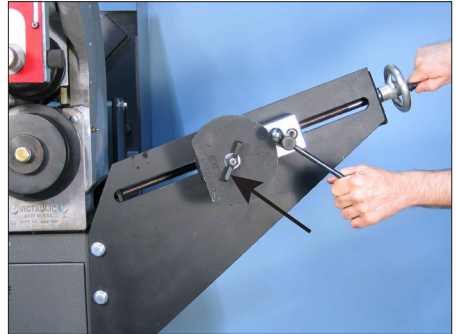

2b. Using the stabilizer handwheel, retract the stabilizer roller to clear the pipe when it is inserted onto the lower roll.



3. Insert a length of pipe that is the correct size and schedule over the lower roll. Ensure that the pipe end contacts the lower-roll backstop flange. The pipe shall rest directly on top of the roll and shall not be skewed to one side or the other.

CAUTION

- **DO NOT** adjust the stabilizer roller to push the pipe to the left and off center from the rolls. Increased pipe-end flare and shortened roll life will result if the pipe is pushed to the left and off center.
- **DO NOT** reach across the pipe to make pipe stabilizer adjustments.
- **DO NOT** adjust the pipe stabilizer while the pipe is in motion.
- **Assembly of couplings on pipe that exceeds the maximum allowable flare dimension may prevent proper pad-to-pad assembly of coupling housings and gasket distortion/damage.**

Failure to prepare pipe in accordance with all instructions may cause joint failure, resulting in property damage or personal injury.



4. Using the stabilizer handwheel, adjust the stabilizer roller toward the pipe.

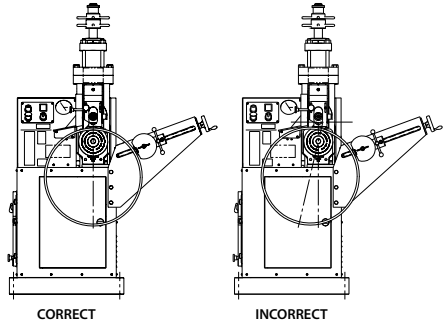

NOTE: DO NOT adjust the stabilizer roller too far inward, since it will skew the pipe to the left and off center, resulting in excessive pipe-end flare. Refer to the drawing above for proper positioning.

5. Position the roller guard so that the roller opening faces the pipe directly. Ensure that the guard does not rub the pipe.

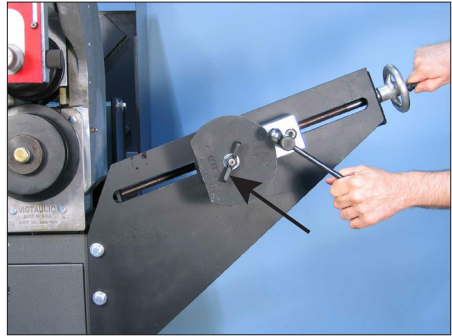

6. Tighten the stabilizer locking handle and the stabilizer-roller-guard wing nut.

7. Complete all adjustments and groove the pipe. Refer to the “Grooving Operation” section. Observe the stabilizer roller while grooving. It should remain in contact with the pipe, and the pipe should rotate smoothly without swaying from side to side. If the pipe is not rotating smoothly or is swaying from side to side, discontinue grooving and adjust the stabilizer roller. Continue the grooving operation and make further adjustments, as necessary.

RAM SPEED ADJUSTMENT

⚠ WARNING

- **Always turn off the main power supply to the tool before making any tool adjustments.**

Failure to follow this instruction could result in serious personal injury.

The ram speed adjustment is factory set for roll grooving carbon steel pipe. When grooving a pipe material other than carbon steel pipe, the ram speed may need to be re-adjusted.

1. Locate the key, which is inserted into the ram speed control valve at the factory.

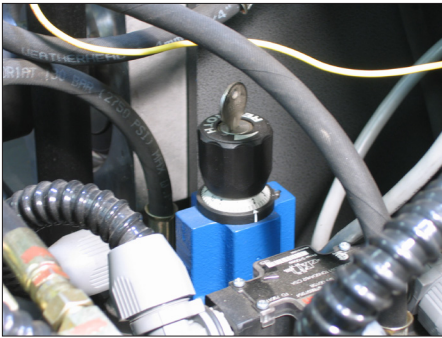

2. Turn the key to unlock the ram speed control valve.

3. With the key inserted into the ram speed control valve, rotate the knob until it “locks in.” Adjust the ram speed control valve to the proper setting, as indicated in the table on this page.

Pipe Material	Ram Speed Control Valve Setting *
Steel	2.5
Steel (Grooved to AGS Specifications)	2.5
Stainless Steel (Type 304/304L and Type 316/316L)	1.5
Stainless Steel (Type 304/304L and Type 316/316L Grooved to AGS Specifications)	2.5
Aluminum (Types 6061-T4 and 6063-T4)	3.0
PVC	10.0

Scale: 1.0 = Slow, 10.0 = Fast

* Settings listed are nominal. Adjustment may be required when different pipe material/grades are being grooved. Refer to the NOTICE below.

4. After the ram speed is set, unlock the ram speed control valve and remove the key. Store the key in a safe location on the tool.

NOTICE

- **The ram speed affects only the rate at which the upper roll forms the groove. It does not affect the rate at which the upper roll advances to contact the pipe, nor does it affect the rate at which the roll retracts from the pipe at the completion of a groove.**
- **Ram speed during the formation of a groove can have a significant effect on pipe flare. The settings listed in the table on this page will produce grooves within Victaulic specifications in most situations. However, if excessive flare results at these settings, reduce the setting to correct the condition. For example, adjust the ram-speed control valve to 1.5 or 2.0 for carbon steel pipe when flare is excessive at the 2.5 setting.**

DWELL CONTROL ADJUSTMENT

The dwell control adjustment controls the length of time the tool continues to rotate the pipe after the groove diameter stop contacts the top of the hydraulic cylinder. The dwell control timer is adjustable for time range and pipe size settings.

When adjusted to the proper pipe size, the pipe will rotate a minimum of one revolution after the groove diameter stop contacts the hydraulic cylinder. This ensures that the groove in the pipe will be of uniform depth around the entire pipe circumference.

TIME RANGE ADJUSTMENT

The time range setting will set the operating parameters of the timer.

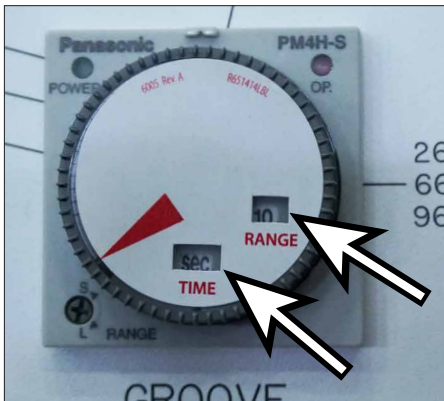

1. To adjust the time range setting, rotate the timer dial counterclockwise completely until the range settings are visible on the dial.

CAUTION

- Use only a #0 Phillips-head screwdriver to adjust the range screw.

Failure to follow this instruction may damage the screw head.

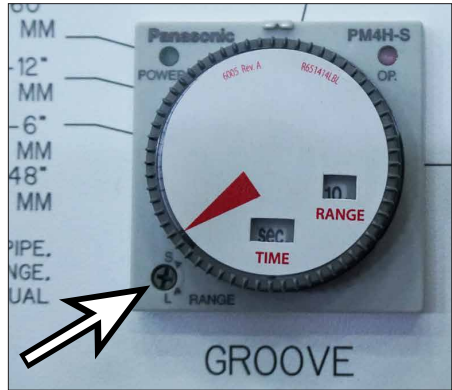

2. If necessary, rotate the time range screw, located in the lower left-hand corner of the timer, to the desired range shown on the dial face.

NOTE: VE460 tools are factory set in the “SEC-10” position. Use only a #0 Phillips head screwdriver to adjust the range screw. Use of any tools other than a #0 Phillips-head screwdriver may damage the screw head.

- For 4–38-inch/114.3–965-mm pipe sizes, set the timer range to “SEC-10”
- For 40–60-inch/1016–1524-mm pipe sizes, set the timer range to “SEC-50”

CAUTION

- The timing range shall be set properly for the pipe size being grooved.

Failure to follow this instruction could cause excessive or insufficient dwell, resulting in improper groove diameters and grooves that are not uniform in depth.

PIPE SIZE ADJUSTMENT

Rotate the timer dial to the appropriate pipe size.

- 4–38-inch/114.3–965-mm pipe sizes are detailed in black. Ensure that the timer range is set to “SEC-10.”
- 40–60-inch/1016–1524-mm pipe sizes are detailed in red. Ensure that the timer range is set to “SEC-50.”



GROOVE DIAMETER STOP ADJUSTMENT

The groove diameter stop shall be adjusted for each pipe size or change in wall thickness. The groove diameter is identified as the “C” dimension (reference the applicable groove specification links on page 63). In addition, a label affixed to the tool lists the “C” dimensions.

NOTICE

- **To perform the following adjustments, use several short, scrap sections of pipe that are the proper material, diameter, and thickness to be grooved. Ensure that the scrap sections meet the length requirements listed in Table 1.**

To achieve the proper diameter:

1. Determine the diameter and thickness of the pipe to be grooved.

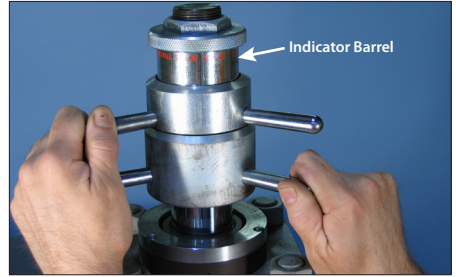

2. Locate the proper diameter and thickness on the pipe size indicator label of the depth stop. The pipe size indicator barrel can be rotated for ease of viewing.

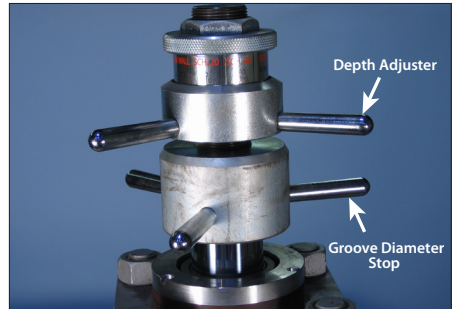

3. Unlock the groove diameter stop (clockwise) from the depth adjuster. Align the top edge of the depth adjuster with the lowest line position of the proper size and schedule markings on the indicator barrel. Hold the depth adjuster to prevent it from turning.



4. Turn the groove diameter stop counter-clockwise to lock the depth adjuster in position.

NOTICE

- Rotating the depth adjusters while locked will cause premature thread wear of the depth adjusters and cylinder ram.
- The markings provide an approximate groove diameter adjustment and are not exact groove diameter settings. Variations in pipe OD and wall thickness make it impossible to calibrate the groove diameter stop exactly.
- Set the initial adjustment shallow (at bottom edge of mark), groove a sample piece of pipe, then make the final adjustment.

NOTICE

- Occasionally during grooving, the groove diameter stop may move up and down slightly, making contact and then breaking contact with the hydraulic cylinder. This is normal for pipe that has a noticeable weld seam or hard spot.

WARNING



Grooving rolls can crush or cut fingers and hands.

- Always turn off the main power supply to the tool before making any tool adjustments.
- Loading/unloading pipe will place your hands close to the rollers. Keep hands away from the grooving rolls and the roller on the pipe stabilizer during operation.
- Never reach inside the pipe ends or across the tool or pipe during operation.
- Always groove pipe in a **CLOCKWISE** direction.
- Never groove pipe that is shorter than the recommended lengths listed in this manual.
- Never wear loose clothing, loose gloves, or anything that can become entangled in moving parts.



6. After a trial groove is prepared and the pipe is removed from the tool, check the groove diameter (“C” dimension) carefully. Reference the applicable groove specification links on page 63. A standard pipe tape, supplied with the tool, is the best method for checking the “C” dimension. In addition, a vernier caliper or narrow-land micrometer can be used to check this dimension at two locations (90° apart) within the groove. The average reading shall be within the required groove diameter specification.

5. Prepare a trial groove. Refer to the “Grooving Operation” section.

CAUTION

- The “C” dimension (groove diameter) shall conform to Victaulic specifications to ensure proper joint performance.

Failure to follow this instruction could cause joint failure, resulting in property damage or personal injury.

7. If the groove diameter (“C” dimension) is not within Victaulic specifications, the diameter stop shall be adjusted.

- Unlock the depth adjusters.
- To adjust for a smaller groove diameter (deeper groove), loosen the groove diameter stop and turn the depth adjuster counter-clockwise (when viewed from above the tool). Turn the groove diameter stop counter-clockwise to lock the depth adjuster in this position.
- To adjust for a larger groove diameter (shallower groove), loosen the groove diameter stop and turn the depth adjuster clockwise (when viewed from above the tool). Turn the groove diameter stop counter-clockwise to lock the depth adjuster in this position.

NOTE: A quarter turn either way will change the groove diameter by 0.042 inch/1.1 mm or 0.167 inch/4.2 mm per full turn.

8. Prepare another trial groove, and check the groove diameter (“C” dimension), as described in previous steps. Repeat these steps, as necessary, until the groove diameter is within specification.

NOTICE

- Rotating the depth adjusters while locked will cause premature thread wear of the depth adjusters and cylinder ram.
- The design of the roll sets will provide the correct “A” and “B” dimensions. If the “A” and “B” dimensions are out of specification, ensure that the pipe is seated properly while grooving. In addition, ensure that the matching roll set is installed on the tool.
- A label is affixed to the tool, which outlines additional dimensional checks:

Pipe and groove features, noted below, must be measured to verify they are within current Victaulic specifications. Victaulic submittal publications can be downloaded at www.victaulic.com.

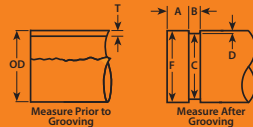

- OD = Average Pipe Outside Diameter
- T = Pipe Wall Thickness
- A = Distance from Pipe End to Groove
- B = Groove Width
- C = Average Diameter at Base of Groove
- D = Groove Depth
- F = Pipe-End Flare

7268 Rev. A

8287264B

GROOVING LONG PIPE LENGTHS

DANGER



- To reduce the risk of electric shock, check the tool for proper grounding and follow all instructions.
- Before operating the tool, review the “Operator Safety Instructions” section of this manual.

Failure to follow these instructions could result in death or serious personal injury.

CAUTION

- For long pipe lengths, ensure that the pipe stand is positioned properly to minimize pipe-end flare.
- **DO NOT** install couplings on pipe that exceeds the maximum allowable flare.
- This tool must be used **ONLY** for grooving pipe with specifications that fall within the designated parameters.
- Verify that the upper and lower grooving rolls are a matched set.
- Always reference the applicable groove specification links on page 63 for details.

Failure to follow these instructions could damage the tool and cause product failure, resulting in property damage or personal injury.

When roll grooving pipe that exceeds the maximum length shown in Table 1, a roller-type pipe stand shall be used. The roller-type pipe stand shall be capable of handling the weight of the pipe, while allowing the pipe to rotate freely.

1. Ensure that the tool is level. Refer to the “Tool Setup” section for leveling requirements.

2. Place the pipe stand at a distance slightly beyond half the pipe length from the tool. Refer to the drawing below.

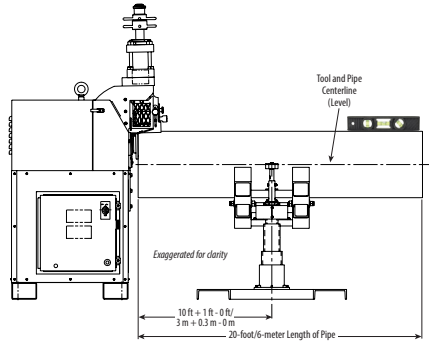

3. Position the pipe stand approximately $0 - \frac{1}{2}$ a degree to the left for the tracking angle. Refer to the drawing below.

NOTE: When pipe flare is excessive, right-to-left tracking shall be kept to a minimum. It may be necessary to use less than $\frac{1}{2}$ a degree for the tracking angle.

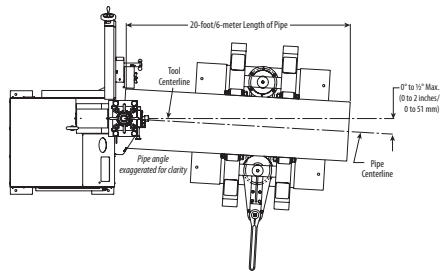

4. If the tool is properly set up in a level position, but the back end of the pipe is higher than the end being grooved, the pipe may not track. In addition, excessive flare may occur on the pipe end. Refer to the “Tool Setup” section and the drawings above for tool setup and pipe positioning requirements.

5. Before grooving, ensure that all instructions in the previous sections of this manual have been followed.

6. Turn on the main power supply to the tool (circuit breaker panel, knife switch, etc.).



7. Turn the main power switch on the side of the tool to the "ON" position.

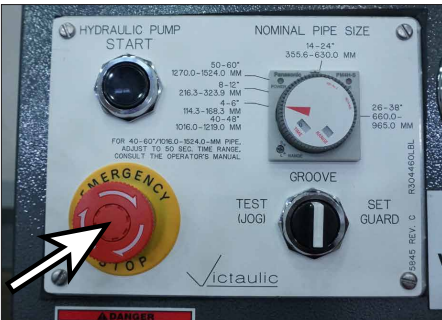

8. Pull the "EMERGENCY STOP" button on the control panel and the electrical enclosure to the out position.

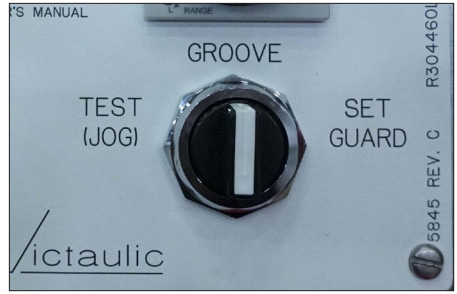

9. Ensure that the selector switch on the control panel is set to the "GROOVE" position.



10. Push the "HYDRAULIC PUMP START" button.

⚠ WARNING

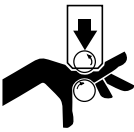

Grooving rolls can crush or cut fingers and hands.

- Always turn off the main power supply to the tool before making any tool adjustments.

- Loading/unloading pipe will place your hands close to the rollers. Keep hands away from the grooving rolls and the roller on the pipe stabilizer during operation.
- Never reach inside the pipe ends or across the tool or pipe during operation.
- Always groove pipe in a **CLOCKWISE** direction.
- Never groove pipe that is shorter than the recommended lengths listed in this manual.
- Never wear loose clothing, loose gloves, or anything that can become entangled in moving parts.



11. Insert a length of pipe that is the correct size, material, and thickness onto the lower roll. Ensure that the pipe end contacts the lower-roll backstop flange completely. Remove hands from the pipe.

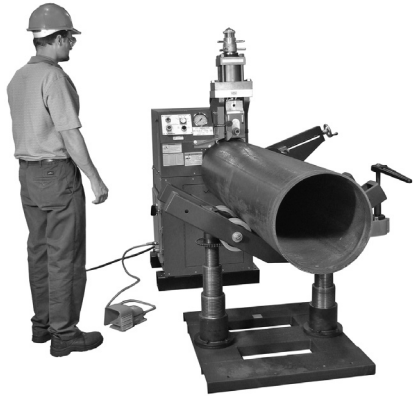

12. The operator should be positioned as shown above.



13. To start the grooving operation, depress and hold down the safety foot switch. This will advance the upper roll into contact with the pipe. The lower roll will start rotating, and the groove will begin to form.

14. During the grooving operation, visually check the tracking of the pipe as it rotates. Ensure that the pipe remains against the lower-roll backstop flange. If the pipe does not stay in contact with the lower-roll backstop flange, stop the tool by releasing the safety foot switch, and withdraw foot from the switch. Ensure that pipe is positioned properly (refer to the “Long Pipe Lengths” section). Repeat steps 10–12.

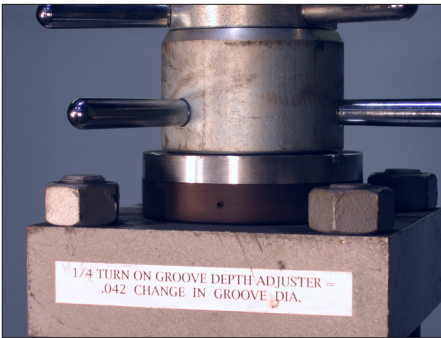

15. As grooving continues, the groove diameter stop will move down and contact the hydraulic cylinder. This contact activates the dwell timer, which allows the pipe to rotate one to three more revolutions to ensure groove completion (refer to the “Dwell Control Adjustment” section). The tool will automatically release the pipe a few seconds later. Release the safety foot switch, and withdraw foot from switch.

16. Inspect the groove/pipe end to ensure they are within Victaulic specifications.

NOTICE

- Occasionally during grooving, the groove diameter stop may move up and down slightly, making contact and then breaking contact with the hydraulic cylinder. This is normal for pipe that has a noticeable weld seam or hard spot.
- Ensure that short pipe lengths are properly supported.

17. If roll grooving will not be performed for an extended time period, turn off the hydraulic system by pushing down (in) either the “EMERGENCY STOP” button on the control panel or the electrical enclosure.

NOTICE

- If pipe remains lodged on the lower roll: Jogging the lower roll will free the pipe. DO NOT attempt to pull the pipe out of the rolls while “jogging” the lower roll. Pull the “EMERGENCY STOP” button on the control panel and the electrical enclosure to the out position, depress the “Hydraulic Pump Start” button, then push down (in) on the “EMERGENCY STOP” button on the control panel and the electrical enclosure to “jog” the lower roll.
- The groove diameter shall be within specification for the diameter and wall thickness of pipe. The groove diameter should be checked and adjusted, as necessary, to ensure grooves remain within specification.

GROOVING SHORT PIPE LENGTHS

⚠ DANGER



- To reduce the risk of electric shock, check the tool for proper grounding and follow all instructions.
- Before operating the tool, review the “Operator Safety Instructions” section of this manual.

Failure to follow these instructions could result in death or serious personal injury.

⚠ CAUTION

- This tool must be used **ONLY** for grooving pipe with specifications that fall within the designated parameters.
- Verify that the upper and lower grooving rolls are a matched set.

Failure to follow these instructions could damage the tool and cause product failure, resulting in property damage or personal injury.

1. Before grooving, ensure that all instructions in the previous sections of this manual have been followed.
2. Turn on the main power supply to the tool (circuit breaker panel, knife switch, etc.).



3. Turn the main power switch on the side of the tool to the “ON” position.



4. Ensure that the selector switch on the control panel is set to the “GROOVE” position.



5. Pull the “EMERGENCY STOP” button on the control panel to the out position, and ensure that the “EMERGENCY STOP” button on the electrical enclosure is pulled to the out position.

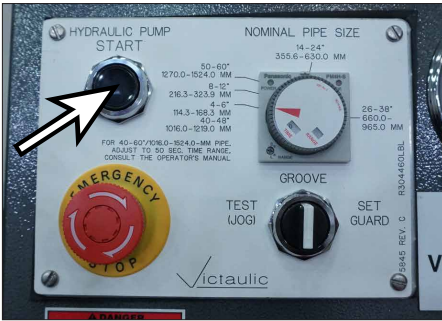

6. Push the “HYDRAULIC PUMP START” button.

WARNING

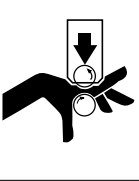

Grooving rolls can crush or cut fingers and hands.

- Always turn off the main power supply to the tool before making any tool adjustments.
- Loading/unloading pipe will place your hands close to the rollers. Keep hands away from the grooving rolls and the roller on the pipe stabilizer during operation.
- Never reach inside the pipe ends or across the tool or pipe during operation.
- Always groove pipe in a COUNTERCLOCKWISE direction.
- Never groove pipe that is shorter than the recommended lengths listed in this manual.
- Never wear loose clothing, loose gloves, or anything that can become entangled in moving parts.

CAUTION

- Pipe shall be supported manually before and after the grooving cycle.
- Failure to follow this instruction could result in personal injury.



7. Insert a length of pipe that is the correct size, material, and thickness onto the lower roll. Ensure that the pipe end contacts the lower-roll backstop flange completely. While manually supporting the pipe, depress and hold down the safety foot switch. The upper roll will advance and contact the pipe. Remove hands from the pipe.

NOTICE

- Occasionally during grooving, the groove diameter stop may move up and down slightly, making contact and then breaking contact with the hydraulic cylinder. This is normal for pipe that has a noticeable weld seam or hard spot.

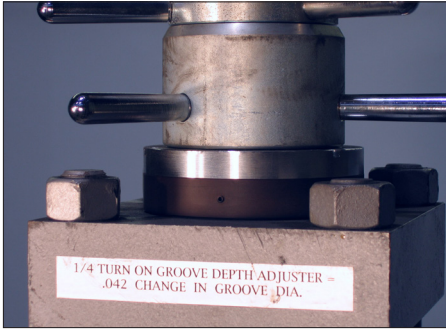

8. As grooving continues, the groove diameter stop will move down and contact the hydraulic cylinder. This contact activates the dwell timer, which allows the pipe to rotate one to three more revolutions to ensure groove completion (refer to the “Dwell Control Adjustment” section).

- a. The upper roll will retract automatically and will release the pipe.
- b. Release the safety foot switch, and withdraw foot from the switch.

9. Inspect the groove/pipe end to ensure they are within Victaulic specifications.

10. If roll grooving will not be performed for an extended time period, turn off the hydraulic system by pushing the “EMERGENCY STOP” button on the control panel or the “EMERGENCY STOP” button on the electrical enclosure.

NOTICE

- **The groove diameter shall be within specification for the diameter and wall thickness of pipe. The groove diameter should be checked and adjusted, as necessary, to ensure grooves remain within specification.**

ROLL CHANGING

VE460 roll grooving tools are designed with rolls to accommodate several pipe sizes and materials, which eliminates the need for frequent roll changes.

When a different pipe size or material is required for grooving, the upper and lower rolls shall be changed. For proper roll selection, refer to the tables on pages 61 – 62.

WARNING

- **Upper and lower rolls are matched components and shall not be intermixed.**

Failure to follow these instructions could result in property damage or serious personal injury.

1. Turn on the main power supply to the tool (circuit breaker panel, knife switch, etc.).



2. Turn the main power switch on the side of the tool to the “ON” position.



3. Pull the “EMERGENCY STOP” button on the control panel and the electrical enclosure to the out position.

5. Push the “HYDRAULIC PUMP START” button.

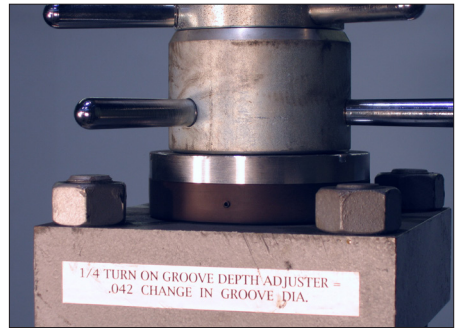

6. Depress the safety foot switch. When the groove diameter stop contacts the hydraulic cylinder, the hydraulic pump will shut off. Release the safety foot switch, and withdraw foot from switch.



4. Place the selector switch on the control panel to the “SET GUARD” mode.



7. Remove the slide spacer by snapping it out of the tool head, as shown above.



8. Push the “HYDRAULIC PUMP START” button to retract (raise) the slide.



9. After the slide is retracted (raised) completely, push the “EMERGENCY STOP” button on the control panel.



10. Turn the main power switch on the side of the tool to the “OFF” position.

LOWER ROLL REMOVAL

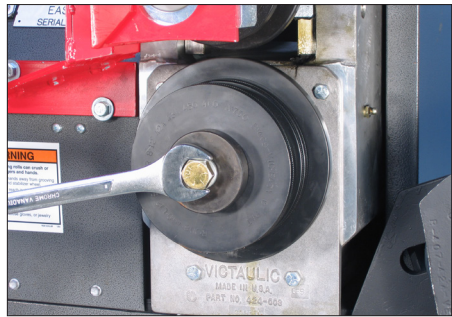

1. Using an appropriate wrench, loosen the lower-roll retaining bolt.

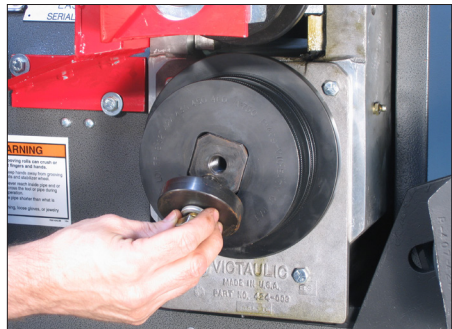

2. Remove the lower-roll retaining bolt and the lower-roll washer.

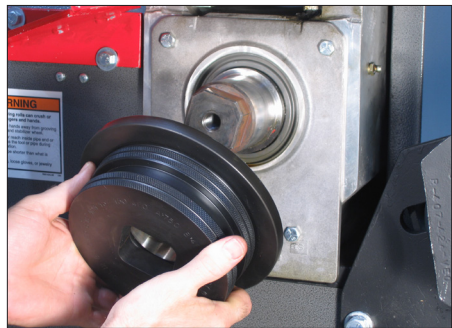

3. Remove the lower roll by pulling it off the main shaft. Store the lower roll inside the tool cabinet. If the lower roll cannot be removed by hand, use a conventional gear puller.

UPPER ROLL REMOVAL

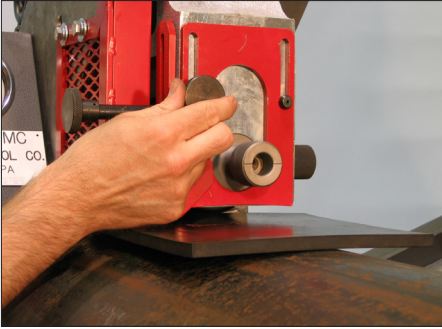

1. Adjust the front roll guard, if necessary, to uncover the upper shaft completely.

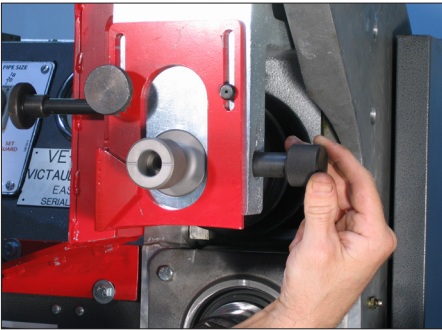

2. Pull the upper shaft locking pin out of the slide until it stops.

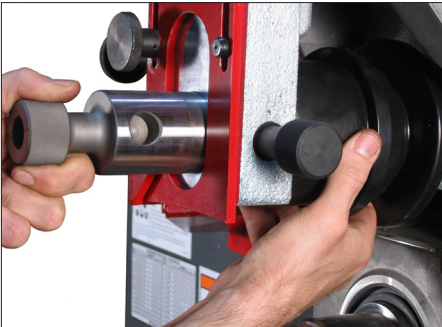

3a. While supporting the upper roll, remove the upper shaft from the upper roll/slide by pulling it straight out.

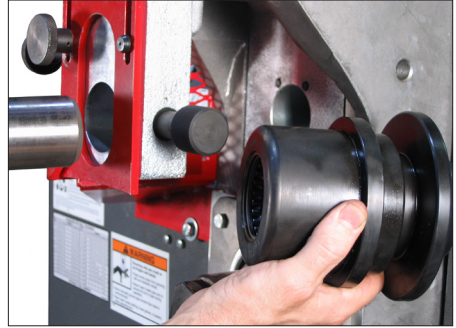

3b. Remove the upper roll. Store the upper roll inside the tool cabinet.

UPPER ROLL INSTALLATION

1. Prior to installation, clean the upper shaft and the upper roll to remove any dirt and scale. Inspect the condition of the bearing in the upper roll. If damage is present, replace any affected components.

NOTE: The upper roll bearings shall be lubricated prior to each use/installation.



2. Install the proper upper roll behind the slide, as shown above. Ensure that the markings on the upper roll are facing forward.

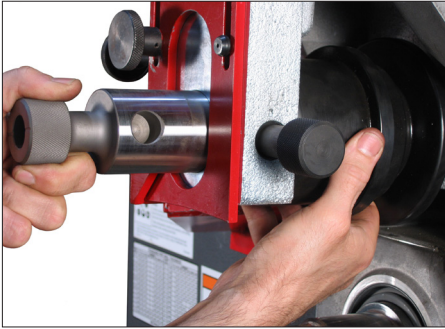

3a. While supporting the upper roll, insert the upper shaft into the slide and upper roll. Align the hole in the upper shaft with the locking pin on the side of the slide.

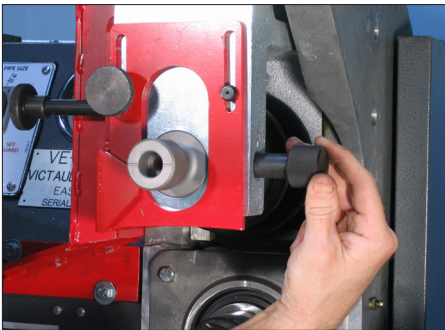

3b. Push the upper shaft locking pin into the slide/upper shaft until it stops.

NOTE: Hole orientation lines are marked on the front of the upper shaft.

LOWER ROLL INSTALLATION



1. Prior to installation, clean the main shaft and the lower roll to remove any dirt and scale.

2. To aid in removing the lower roll at a later time, a dry graphite spray or anti-seize lubricant can be applied to the main shaft before the lower roll is installed.



3. Align the square end of the main shaft with the square hole in the lower roll. Push the lower roll completely onto the main shaft. Ensure that the markings on the lower roll are facing out.



4. Install the lower-roll washer and lower-roll retaining bolt.



5. Tighten the lower-roll retaining bolt completely to secure the lower roll onto the main shaft.



6. Turn the main power switch on the side of the tool to the "ON" position.



7. Pull the "EMERGENCY STOP" button on the control panel to the out position.

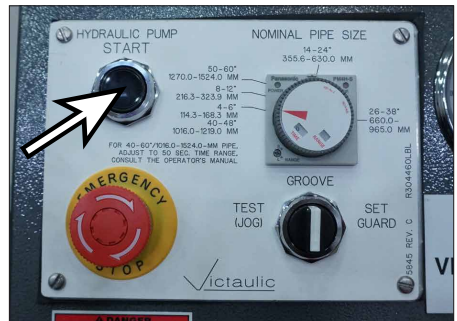

8. Push the "HYDRAULIC PUMP START" button.



9. Place the selector switch on the control panel to the "SET GUARD" mode. Depress and hold the safety foot switch. The upper roll and slide will start to move downward.

CAUTION

- The upper roll is free floating. Ensure that the upper roll is positioned toward the back of the upper shaft.

Failure to follow this instruction could result in damage to the flange of the upper and lower rolls.



10. After the upper roll/slide has advanced approximately 1 inch/25 mm and the rolls are aligned and engaged, push the “EMERGENCY STOP” button on the control panel.



11. Snap the slide spacer into the tool, as shown above.



12. Pull the “EMERGENCY STOP” button on the control panel to the out position.



13. Push the “HYDRAULIC PUMP START” button to fully retract (raise) the slide.



14. After the slide has retracted (raised) completely, push the “EMERGENCY STOP” button on the control panel.



15. Grease the upper shaft bearings, as shown, by applying grease through the lubrication fitting on the front of the upper shaft. Refer to the applicable “Recommended Lubricants” table for the proper grease.

16. Roll set installation is now complete. Before grooving, ensure that all instructions in the previous sections of this manual have been followed (i.e. adjusting the roll guards, adjusting the groove diameter stop, etc.).

MAINTENANCE

⚠ DANGER



- Always turn off the main power supply to the tool before making any tool adjustments or before performing any maintenance.

Failure to follow this instruction could result in death or serious personal injury.

This section provides information about keeping tools in proper operating condition and guidance for making repairs when it becomes necessary.

Replacement parts shall be ordered from Victaulic to ensure proper and safe operation of the tool.



Before making any tool adjustments or before performing maintenance on the tool, turn off the main power supply (main circuit breaker panel, knife switch, etc.). Lock the switch in the “OFF” position to prevent accidental engagement.

NOTE: Victaulic does not supply this lockout mechanism.

LUBRICATION

1. After every 8 hours of operation, lubricate the tool. **Always lubricate the upper roll bearings when rolls are changed.**

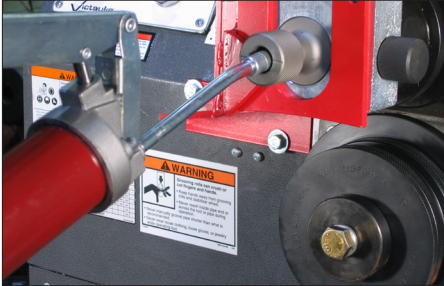

2. Grease the upper shaft bearings every time roll changes are made and after every 8 hours of operation. A grease fitting is provided on the front of the upper shaft. Refer to the applicable "Recommended Lubricants" table for the proper grease.



3. Grease the slide gibs. The slide gib grease fitting is located on the back of the slide and is accessible when the tool hood is open.

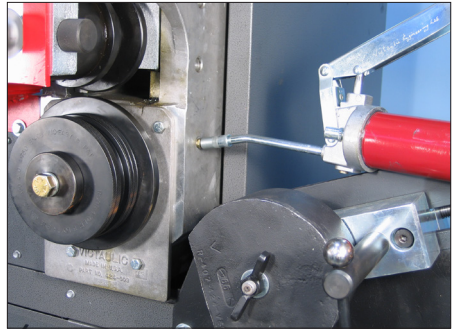

4. Grease the main shaft bearings through the fitting located on the side of the tool.



5a. Remove the stabilizer-roller-guard wing nut and stabilizer roller guard.



5b. Grease the stabilizer roller.

5c. Replace the stabilizer roller guard and stabilizer-roller-guard wing nut.

CHECKING AND FILLING GEAR REDUCER OIL

The gear reducer oil level shall be checked every six months or 2,500 operating hours, whichever comes first. Oil shall be changed more often if the tool is used in a severe environment (i.e. dusty, humid). If leakage is present, repairs shall be made to correct the leak. **NOTE:** The gear reducer's oil capacity is 75 oz (2 liters).

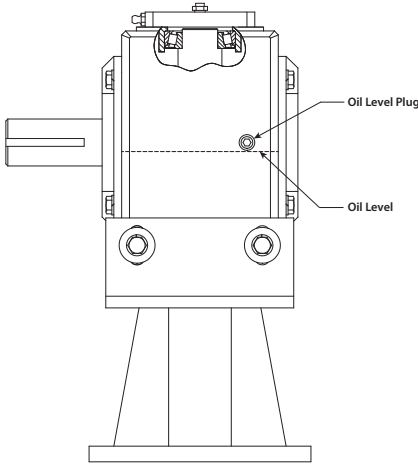

1. Remove the oil level plug from the gear reducer (refer to drawing above). The oil level should be even with the bottom of the hole.
2. To add oil, remove the oil level plug from the gear reducer and fill to the proper level (refer to drawing above). Refer to the tag attached to the gear reducer for the required gear oil.
3. Re-install the oil level plug.

GEAR REDUCER INPUT SHAFT

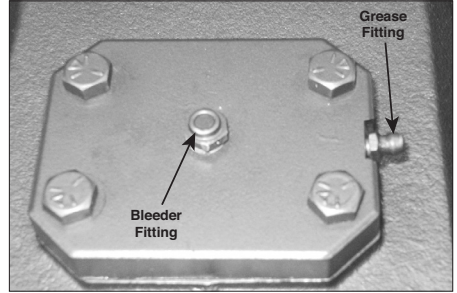

1. The gear reducer's input shaft cover contains a grease fitting (shown above). This grease fitting is located on the chain coupling side of the gear reducer. A bleeder fitting is located on the center of the gear reducer's input shaft cover (shown above).

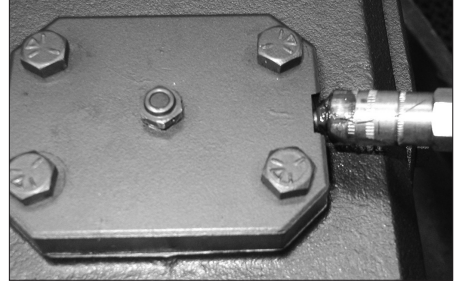

2. Lubricate the input shaft bearing after every 40 hours of operation. This fitting must be lubricated with a No. 2EP Lithium-base grease until it weeps from the bleeder fitting.

CHECKING AND FILLING HYDRAULIC OIL

1. The hydraulic oil level shall be checked every month or 50 operating hours, whichever comes first. Check the hydraulic oil level preferably before tool startup. The level should be no lower than 1–2 inches/25–50 mm from the top of the hydraulic oil reservoir. DO NOT over-fill the hydraulic oil reservoir, since the oil may overflow due to thermal expansion. Refer to the “Recommended Lubricants” table for the proper hydraulic oil.

REPLACING HYDRAULIC OIL AND FILTER

Replace the hydraulic oil and hydraulic oil filter annually or every 2,000 operating hours, whichever comes first.

1. Raise the hood of the tool.

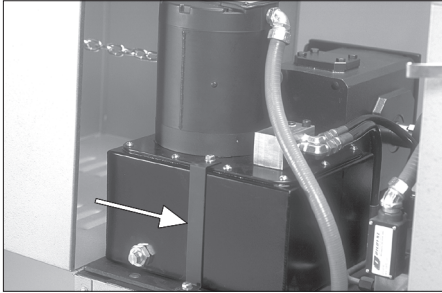

2. Locate the two brackets that hold the hydraulic oil reservoir to the frame.



3. Loosen the screws on the bracket closest to the drain plug. Remove the bracket and set it aside.

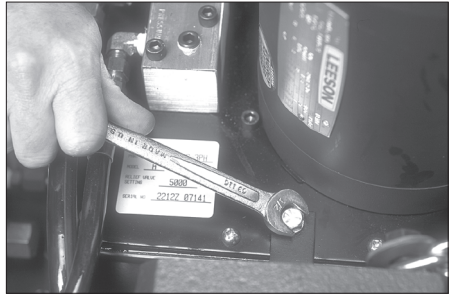

4. On the other bracket, loosen and remove the screw on top of the hydraulic oil reservoir. It is not necessary to loosen the screw that holds the bracket to the frame.

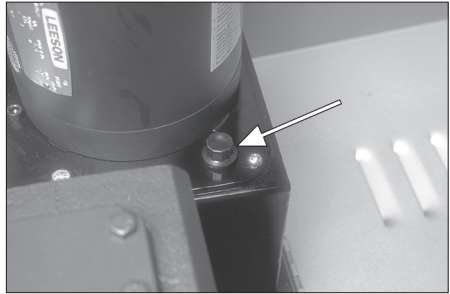

5. Remove the fill/vent plug from the top of the hydraulic oil reservoir.

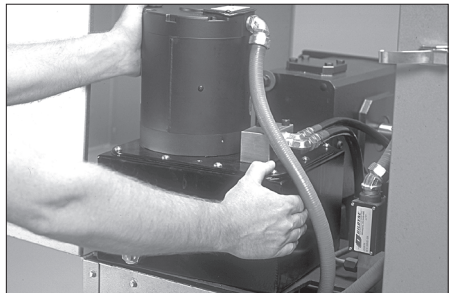

6. Slide the hydraulic oil reservoir partially over the side of the tool. Do NOT disconnect any electrical or hydraulic lines.

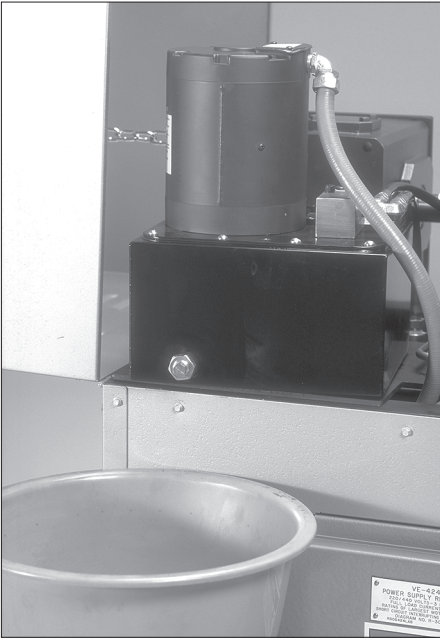

7. Position a container underneath the drain plug. Ensure that the container is large enough to hold 2 gallons/8 liters of hydraulic oil.



8. Remove the drain plug to drain the old hydraulic oil from the hydraulic oil reservoir.

NOTICE

- Reference local ordinances regarding the proper disposal of hydraulic oil.



9. Replace the drain plug. Slide the hydraulic oil reservoir back into position and reattach the brackets.



10. Place a tray under the hydraulic oil filter. Remove the hydraulic oil filter.



11. Lubricate the gasket of the new hydraulic oil filter with new hydraulic oil. Fill the filter with new hydraulic oil, then install it hand-tight into the tool.

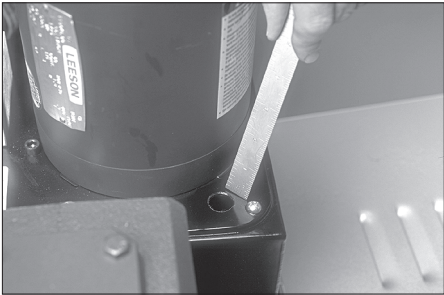

12. Fill the hydraulic oil reservoir with new hydraulic oil until the level reaches 1–2 inches/ 25–50 mm from the top of the hydraulic oil reservoir. Refer to the “Recommended Lubricants” section.

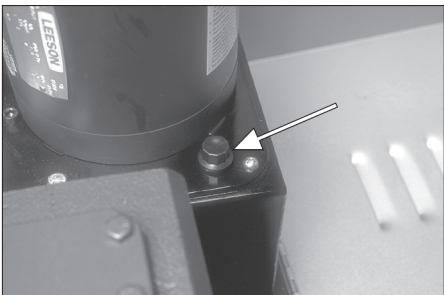

13. Install the fill/vent plug.

14. Turn on the main power supply to the tool (circuit breaker panel, knife switch, etc.).



15. Turn the main power switch on the side of the tool to the “ON” position.



16. Pull the “EMERGENCY STOP” button on the control panel and the electrical enclosure to the out position.

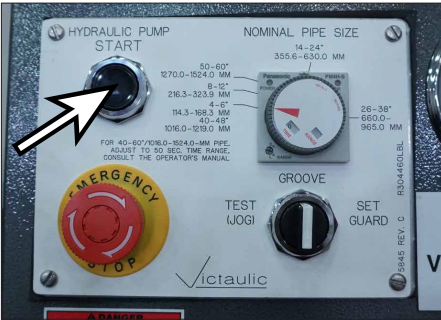

17. Push the “HYDRAULIC PUMP START” button. Allow the hydraulic pump to run for 3–5 minutes.

18. Inspect the hydraulic system for leaks.



19. Turn off the hydraulic system by pushing the “EMERGENCY STOP” button on the control panel.

20. Check the hydraulic oil level. Add oil, as necessary.

21. Follow the “Air Bleeding” section.

AIR BLEEDING

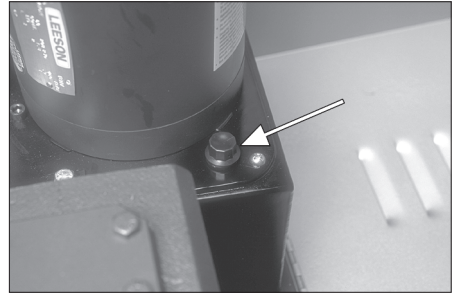

1. Remove the fill/vent plug from the hydraulic oil reservoir.

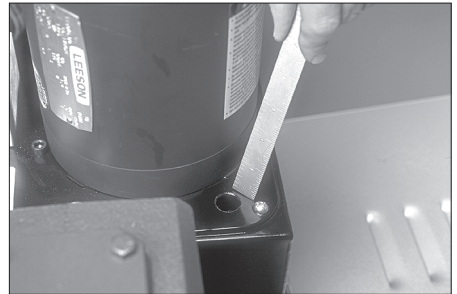

2. Fill the hydraulic oil reservoir with new hydraulic oil until the level reaches 1–2 inches/25–50 mm from the top of the hydraulic oil reservoir. Refer to the “Recommended Lubricants” section.



3. Remove the plug from the tee at the bottom of the hydraulic cylinder port.

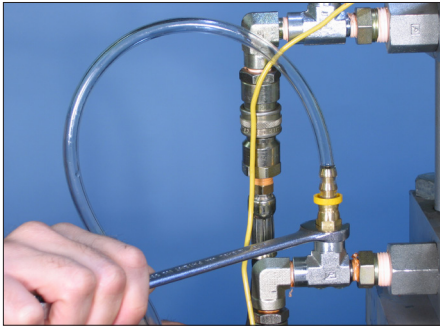

4. Install the bleeder tube into the tee, as shown above. Insert the other end of the bleeder tube into the fill/vent hole in the hydraulic oil reservoir. **NOTE:** The bleeder tube consists of a ¼-inch NPT barb hose fitting and 4 feet/1.2 m of ¼-inch ID clear vinyl hose (supplied).

5. Turn on the main power supply to the tool (circuit breaker panel, knife switch, etc.).



6. Turn the main power switch on the side of the tool to the “ON” position.



7. Pull the “EMERGENCY STOP” button on the control panel to the out position.



8. Push the “HYDRAULIC PUMP START” button. Hydraulic oil will start flowing from the tee through the bleeder tube and into the hydraulic oil reservoir.



9. Place the selector switch on the control panel to the “SET GUARD” mode.

10. Depress the safety foot switch, hold it down for 5 seconds, then release it for 5 seconds. Repeat this step until no air bubbles can be seen through the clear vinyl tube.



11. Push the “EMERGENCY STOP” button on the control panel.

NOTICE

- To prevent oil from flowing out of the tee while removing the bleeder tube and installing the plug: Block the groove diameter stop from moving down by inserting a piece of wood between the groove diameter stop and the top of the hydraulic cylinder.



12. Remove the bleeder tube, and install the plug into the tee. **DO NOT ALLOW AIR TO GET BACK INTO THE TEE WHEN INSTALLING THE PLUG (REFER TO NOTICE BELOW).**

NOTICE

- To prevent air from entering the tee while the bleeder tube is removed and the plug is installed: Hold the 4-way valve in the “shifted” position by pressing in on the rubber boot on the end of the valve. Keep the rubber boot depressed until the plug is installed and tightened.

13. Repeat steps 3 – 10 for bleeding air from the tee at the top of the hydraulic cylinder port.

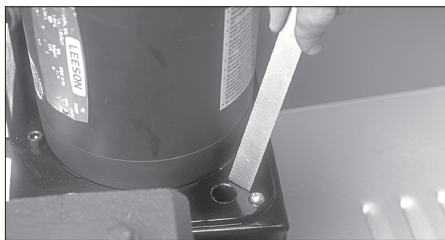

14. Bring the hydraulic oil level up to 1–2 inches/25–50 mm from the top of the hydraulic oil reservoir. DO NOT over-fill the hydraulic oil reservoir, since the oil may overflow due to thermal expansion. Refer to the applicable “Recommended Lubricants” table for the proper hydraulic oil.

RECOMMENDED LUBRICANTS

BEARING AND SLIDE GREASE

NLGI #2 Summer Grade graphite moly base
(General Purpose EP Lithium Base Grease)

Manufacturer	Product
BP Amoco	Energrease LC-EP2
Gulf Oil Corp.	Gulfcrown Grease EP#2
Lubriplate	No. 630-2
Mobil Oil Corp.	Mobilux EP2
Pennzoil Products Co.	Pennlith EP 712 Lube
Shell Oil Co.	Alvania EP2
Sun Refining	Sun Prestige 742 EP
Texaco Inc.	Multifak EP2

GEAR OIL

Refer to the tag located on the gear reducer.

HYDRAULIC OIL

(High Pressure, Anti-Wear/Anti-Foam Hydraulic Oil ISO Grade 32)

Manufacturer	Product
BP Amoco	Energol HLP-HM32
Gulf Oil Corp.	Harmony 32 AW
Kendall Refining Co.	Kenoil R&O AW-32
Lubriplate	HO-o
Mobil Oil Corp.	Mobil DTE 24
Pennzoil Products Co.	Pennzbell AW32
Shell Oil Co.	Tellus 32
Sun Refining	Survis 832
Texaco Inc	Rando

PARTS ORDERING INFORMATION

When ordering parts, the following information is required for Victaulic to process the order and send the correct part(s). Parts can be ordered by calling 1-800-PICK-VIC.

1. Tool Model Number
2. Tool Serial Number
3. Quantity, Item Number, Part Number, and Description
4. Where to send the part(s) – Company Name and Address
5. To whose attention to send the part(s) – Person’s Name
6. Purchase Order Number
7. Billing Address



ACCESSORIES

VAPS112 VICTAULIC ADJUSTABLE PIPE STAND



The Victaulic VAPS112 Pipe Stand is a portable, adjustable, roller-type pipe stand that contains four legs for additional stability. The VAPS112 supports pipe sizes ¾ to 12 inches/26.9 to 323.9 mm (1½-foot/0.5-meter to full, single 20-foot/6-meter random lengths) and has a load rating of 1075 pounds/490 kilograms. The turnstile design permits ease of grooving for both pipe ends. Contact Victaulic for details.

VAPS224 VICTAULIC ADJUSTABLE PIPE STAND



The Victaulic VAPS224 Pipe Stand contains features that are similar to the VAPS112, but supports pipe sizes 2 to 24 inches/60.3 to 610.0 mm (1½-foot/0.5-meter to full, single 20-foot/6-meter random lengths) and has a load rating of 1800 pounds/817 kilograms. Contact Victaulic for details.

OPTIONAL ROLLS

Refer to the tables on pages 61 – 62, which identify rolls that are available for different pipe materials and groove specifications.

TROUBLESHOOTING

PROBLEM	POSSIBLE CAUSE	SOLUTION
Pipe will not stay in grooving rolls.	Incorrect pipe positioning of long pipe length. Lower roll and pipe are not rotating clockwise.	Refer to the “Long Pipe Lengths” section. Refer to the “Power Hookup and Verification of Pipe Rotation Direction” section.
Pipe stops rotating during the grooving operation.	Rust or dirt buildup is present on the lower roll. Rust or dirt is excessively heavy inside the pipe end. Worn grooving rolls. The circuit breaker has tripped or a fuse/thermal overload relay has blown out on the electrical circuit that supplies the tool.	Remove rust or dirt accumulation from the lower roll with a stiff wire brush. Remove heavy rust and dirt from inside the pipe end. Inspect the lower roll for worn knurls. Replace the lower roll if excessive wear is present. Reset the breaker, or replace the fuse/thermal overload relay.
While grooving, loud squeaks echo through the pipe.	Incorrect pipe support positioning of a long pipe length. Pipe is “over-tracking.” Pipe is not cut square. Pipe is rubbing excessively on the lower-roll backstop flange. Ram speed is set too low. Tool bearings are not lubricated.	Move the pipe support to the right. Refer to the “Long Pipe Lengths” section. Cut the pipe end squarely. Remove the pipe from the tool, and apply a light coating of bandsaw blade wax to the face of the pipe end. Refer to the “Ram Speed Adjustment” section. Refer to the “Maintenance” and “Lubrication” sections.

PROBLEM	POSSIBLE CAUSE	SOLUTION
During grooving, loud thumps or bangs occur approximately once every revolution of the pipe.	Pipe has a pronounced weld seam.	For 12-inch/323.9-mm and smaller pipe sizes, raised internal and external weld beads and seams shall be ground flush with the pipe surface 2 inches/50 mm back from the pipe ends. For 14 - 38-inch/355.6 - 965-mm pipe sizes, raised internal and external weld beads and seams shall be ground flush with the pipe surface 4 inches/100 mm back from the pipe ends. For 40 - 60-inch/1016 - 1524-mm pipe sizes, raised internal and external weld beads and seams shall be ground flush with the pipe surface 4 ½ inches/115 mm back from the pipe ends.
Pipe flare is excessive.	Pipe support is adjusted too high for long pipe. Tool is tilted forward (out of level) while grooving long pipe. Incorrect pipe support positioning of long pipe. Pipe is “over-tracking.” Pipe stabilizer is adjusted too far inward. Ram speed is not set correctly.	Refer to the “Long Pipe Lengths” section. Refer to the applicable “Tool Setup” section. Move the pipe support to the right. Refer to the “Long Pipe Lengths” section. Back off the pipe stabilizer to the furthest point where it still stabilizes the pipe effectively. Refer to the “Ram Speed Adjustment” section.
Larger diameter pipe sways or vibrates from side to side.	Incorrect pipe stabilizer adjustment.	Move the pipe stabilizer in or out until the pipe rotates smoothly.
Tool will not groove the pipe.	Air is present in the hydraulic system. Pipe is beyond the wall thickness or pipe yield strength capacity of the tool.	Refer to the “Air Bleeding” section. Refer to the tables on page 60.
Pipe groove diameters do not meet Victaulic specifications.	Groove diameter stop is not adjusted properly. Pipe is beyond the wall thickness or pipe yield strength capacity of the tool. Incorrect upper roll, lower roll, or both installed on the tool	Refer to the “Groove Diameter Stop Adjustments” section. Refer to the tables on page 60. Install the correct rolls. Refer to the tables on pages 61 – 62.
The “A” Gasket Seat or “B” Groove Width dimensions do not meet Victaulic specifications.	Upper roll bearing is not lubricated adequately. Incorrect upper roll, lower roll, or both installed on the tool Pipe not inserted fully onto the lower roll, or pipe is not tracking properly.	Refer to the “Maintenance” section. Install the correct rolls. Refer to the tables on pages 61 – 62. Ensure that pipe is against the lower-roll backstop flange. Refer to the “Long Pipe Lengths” section for proper pipe stand positioning.

In the event of tool malfunction outside the scope of the troubleshooting section, contact Victaulic for assistance.

NOTICE

- The “Maximum Pipe Size and Wall Thickness Capacity” tables on the following page are accurate as of the date printed on the back cover of this manual. For the most up-to-date information, reference Victaulic publication 24.01, which can be viewed/downloaded by scanning the mobile QR code link to the right, or by clicking on this desktop link: <https://www.victaulic.com/assets/uploads/literature/24.01.pdf>



VE460 RATINGS - MAXIMUM PIPE SIZE AND WALL THICKNESS CAPACITY (OGS AND OGS-200)

		Pipe Size (inches/mm)												
Model	Pipe Material	Notes	4	5	6	8	10	12	14	16	18	20	22	24
VE460	Steel (OGS)	2, 5	Sch. 5 – 80 2.1 – 9.5 mm	Sch. 5 – 40 2.8 – 8.2 mm	Sch. 5 – 40 2.8 – 8.2 mm	Sch. 5 – X5 3.4 – 12.7 mm								
	Steel (OGS-200)	4		Sch. 40 – 80 8.2 – 12.7 mm	Sch. 40S 6.0 – 9.3 mm									
	Stainless (OGS)				Sch. 40S 6.0 – 9.3 mm				STD 9.5 mm					
	Stainless (OGS-200)				Sch. 40 8.2 mm									
	Lt. Wall SS	6		Sch. 5S – 10S 2.1 – 4.6 mm	Sch. 5S – 10S 2.1 – 4.6 mm				Sch. 5S – 10S, TRUE 10 4.0 – 4.8 mm, 6.4 mm					
	Aluminum	1		Sch. 5 – 40 2.1 – 10.3 mm										
	PVC Plastic	3	Sch. 40 – 80 6.0 – 11.0 mm	Sch. 40 8.2 mm										

- 1 6061-T4 or 6063-T4 Alloy must be used.
- 2 EndSeal™ grooving rolls marked with the prefix RZ are available. Refer to the following page.
- 3 Use grooving rolls marked with the prefix RP.
- 4 OGS-200 for use with Style 870 Rigid Coupling
- 5 Use standard grooving rolls marked with the prefix R for OGS and RW for AGS.
- 6 Use grooving rolls marked with the prefix RX for OGS and RWX for AGS. (Special RWX Rolls are available for grooving true Sch. 10 (0.250 | 6.4 mm).

VE460 RATINGS - MAXIMUM PIPE SIZE AND WALL THICKNESS CAPACITY *AGS*

		Pipe Size (inches/mm)																						
Model	Pipe Material	Notes	14	16	18	20	22	24	26	28	30	32	34	36	38	40	42	44	46	48	50	54	56	60
VE460	Steel	2			.250 – .500 6.4 – 12.7 mm																			
	Stainless				STD 9.5 mm																			
	Lt. Wall SS	6	Sch. 5S – 10S, TRUE 10 4.0 – 4.8 mm, 6.4 mm																					

- Capable of grooving up to .375-inch/9.5-mm nominal wall thickness API Specification 5L, Grade B with a maximum yield strength of 50,000 psi. For higher yield strength, use the 50T.
- Capable of grooving up to .500-inch/12.7-mm nominal wall thickness API Specification 5L, Grade B with a maximum yield strength of 42,000 psi. For higher yield strength, use the 50T.

ORIGINAL GROOVE SYSTEM (OGS) ROLL PART NUMBERS

STEEL AND SCHEDULE 40 STAINLESS STEEL PIPE - COLOR CODED BLACK

(For light-wall stainless steel pipe, refer to separate table on this page)

Pipe Size inches/mm	Roll Part Numbers
4	Lower Roll R904460L06 Upper Roll R9QA448U06 Roll Set R9Q1460006
100	
5	
125	Lower Roll R908460L12 Upper Roll R9QA448U12 Roll Set R9Q1460012
6	
150	
8	Lower Roll R914460L16 Upper Roll R9QA448U16 Roll Set R9Q1460016
200	
10	
250	Lower Roll R918460L20 Upper Roll R9QA448U20 Roll Set R9Q1460020
12	
300	
14	Lower Roll R922460L24 Upper Roll R9QA448U24 Roll Set R9Q1460024
350	
16	
400	Lower Roll RX04460L06 Upper Roll RXQA448U06 Roll Set RXQ1460006
18	
450	
20	Lower Roll RX18460L20 Upper Roll RXQA448U20 Roll Set RXQ1460020
500	
22	
550	Lower Roll RX22460L24 Upper Roll RXQA448U24 Roll Set RXQ1460024
24	
600	

ENDSEAL “ES” ROLL PART NUMBERS

STEEL PIPE - COLOR CODED BLACK

Pipe Size inches/mm	Roll Part Numbers
4	Lower Roll RZ04460L06 Upper Roll RZQA448U06 Roll Set RZQ1460006
100	
5	
125	Lower Roll RZ08460L12 Upper Roll RZQA448U12 Roll Set RZQ1460012
6	
150	
8	Lower Roll RZ14460L16 Upper Roll RZQA448U16 Roll Set RZQ1460016
200	
10	
250	Lower Roll RZ18460L20 Upper Roll RZQA448U20 Roll Set RZQ1460020
12	
300	
22	Lower Roll RZ22460L24 Upper Roll RZQA448U24 Roll Set RZQ1460024
550	
24	
600	Lower Roll RX08460L12 Upper Roll RXQA448U12 Roll Set RXQ1460012
14	
350	
16	Lower Roll RX14460L16 Upper Roll RXQA448U16 Roll Set RXQ1460016
400	
18	
450	Lower Roll RX18460L20 Upper Roll RXQA448U20 Roll Set RXQ1460020
20	
500	
22	Lower Roll RX22460L24 Upper Roll RXQA448U24 Roll Set RXQ1460024
550	
24	
600	Lower Roll RX04460L06 Upper Roll RXQA448U06 Roll Set RXQ1460006
4	
100	
5	Lower Roll RX08460L12 Upper Roll RXQA448U12 Roll Set RXQ1460012
125	
6	
150	Lower Roll RX14460L16 Upper Roll RXQA448U16 Roll Set RXQ1460016
8	
200	
10	Lower Roll RX18460L20 Upper Roll RXQA448U20 Roll Set RXQ1460020
250	
12	
300	Lower Roll RX22460L24 Upper Roll RXQA448U24 Roll Set RXQ1460024
14	
350	
16	Lower Roll RX04460L06 Upper Roll RXQA448U06 Roll Set RXQ1460006
400	
18	
450	Lower Roll RX18460L20 Upper Roll RXQA448U20 Roll Set RXQ1460020
20	
500	
22	Lower Roll RX22460L24 Upper Roll RXQA448U24 Roll Set RXQ1460024
550	
24	
600	Lower Roll RX08460L12 Upper Roll RXQA448U12 Roll Set RXQ1460012
4	
100	
5	Lower Roll RX04460L06 Upper Roll RXQA448U06 Roll Set RXQ1460006
125	
6	
150	Lower Roll RX14460L16 Upper Roll RXQA448U16 Roll Set RXQ1460016
8	
200	
10	Lower Roll RX18460L20 Upper Roll RXQA448U20 Roll Set RXQ1460020
250	
12	
300	Lower Roll RX22460L24 Upper Roll RXQA448U24 Roll Set RXQ1460024
14	
350	

ORIGINAL GROOVE SYSTEM (OGS) ROLL PART NUMBERS

ALUMINUM AND PVC PLASTIC PIPE - COLOR CODED YELLOW ZINC

Pipe Size inches/mm	Roll Part Numbers
4	Lower Roll RP04460L06 Upper Roll RPQA448U06 Roll Set RPQ1460006
100	
5	
125	Lower Roll RP08460L12 Upper Roll RPQA448U12 Roll Set RPQ1460012
6	
150	
8	Lower Roll RP14460L16 Upper Roll RPQA448U16 Roll Set RPQ1460016
200	
10	
250	Lower Roll RX04460L06 Upper Roll RXQA448U06 Roll Set RXQ1460006
12	
300	

ORIGINAL GROOVE SYSTEM (OGS) ROLL PART NUMBERS

SCHEDULE 5S AND 10S STAINLESS STEEL PIPE - COLOR CODED SILVER

Pipe Size inches/mm	Roll Part Numbers
4	Lower Roll RX04460L06 Upper Roll RXQA448U06 Roll Set RXQ1460006
100	
5	
125	Lower Roll RX08460L12 Upper Roll RXQA448U12 Roll Set RXQ1460012
6	
150	
8	Lower Roll RX14460L16 Upper Roll RXQA448U16 Roll Set RXQ1460016
200	
10	
250	Lower Roll RX18460L20 Upper Roll RXQA448U20 Roll Set RXQ1460020
12	
300	
14	Lower Roll RX22460L24 Upper Roll RXQA448U24 Roll Set RXQ1460024
350	
16	
400	Lower Roll RX04460L06 Upper Roll RXQA448U06 Roll Set RXQ1460006
18	
450	
20	Lower Roll RX18460L20 Upper Roll RXQA448U20 Roll Set RXQ1460020
500	
22	
550	Lower Roll RX22460L24 Upper Roll RXQA448U24 Roll Set RXQ1460024
24	
600	

ADVANCED GROOVE SYSTEM **AGS**™ ROLL PART NUMBERS

STEEL PIPE - COLOR CODED BLACK WITH YELLOW BAND

STAINLESS STEEL PIPE - COLOR CODED SILVER WITH BLACK BAND

Pipe Size inches/ mm	Roll Part Numbers for Steel Pipe	Roll Part Numbers for Stainless Steel Pipe
14 350	Lower Roll RW02460L24 Upper Roll RWQ2448ASY Roll Set RWQ2460024	Lower Roll RWQX448L18 Upper Roll RWQX448A24 Roll Set RWQX460018
16 400		
18 450		
20 500		
22 550		Lower Roll RW0X460L24 Upper Roll RWQX448A24 Roll Set RWQX460024
24 600		
26 650		
28 700	Lower Roll RWQ3460L38 Upper Roll RWQ3460A38 Roll Set RWQ3460038	
30 750		
32 800		
34 850		
36 900		
38 950		

Pipe Size inches/ mm	Roll Part Numbers for Steel Pipe	Roll Part Numbers for Stainless Steel Pipe
40 1000	Lower Roll RWQ3460L50 Upper Roll RWQ3460A50 Roll Set RWQ3460050	
42 1050		
44 1100		
46 1150		
48 1200		
50 1250		
54 1350		
56 1400		
60 1500		

OGS GROOVE SPECIFICATIONS

For the most up-to-date information regarding OGS roll groove specifications, reference the current revision of Victaulic publication 25.01, which can be viewed/downloaded by scanning the mobile QR code link to the right, or by clicking on this desktop link:

<https://www.victaulic.com/assets/uploads/literature/25.01.pdf>



ENDSEAL “ES” GROOVE SPECIFICATIONS

For the most up-to-date information regarding EndSeal “ES” roll groove specifications, reference the current revision of Victaulic publication 25.02, which can be viewed/downloaded by scanning the mobile QR code link to the right, or by clicking on this desktop link:

<https://www.victaulic.com/assets/uploads/literature/25.02.pdf>



AGS GROOVE SPECIFICATIONS

For the most up-to-date information regarding AGS roll groove specifications, reference the current revision of Victaulic publication 25.09, which can be viewed/downloaded by scanning the mobile QR code link to the right, or by clicking on this desktop link:

<https://www.victaulic.com/assets/uploads/literature/25.09.pdf>



ADDITIONAL RESOURCES

For additional information on 24-inch/DN600 and smaller Victaulic mechanical piping products for carbon steel, stainless steel, aluminum, and CPVC/PVC pipe, reference the current revision of the I-100 Field Installation Handbook, which can be viewed/downloaded by scanning the mobile QR code link to the right, or by clicking on this desktop link:

<https://www.victaulic.com/assets/uploads/literature/I-100.pdf>



For additional information on Victaulic Advanced Groove System (AGS) products, reference the current revision of the I-W100 Field Installation Handbook, which can be viewed/downloaded by scanning the mobile QR code link to the right, or by clicking on this desktop link:

<https://www.victaulic.com/assets/uploads/literature/I-W100.pdf>



EC DECLARATION OF CONFORMITY

In Accordance with the Machinery Directive 2006/42/EC

Victaulic Company, headquartered at 4901 Kesslersville Road, Easton, PA 18040, USA, hereby declares that the machinery listed below complies with the essential safety requirements of the Machinery Directive, 2006/42/EC.

Product Models:	VE460
Serial No. :	Refer to Machinery Nameplate
Product Description:	Pipe Roll Grooving Tool
Conformity Assessment:	2006/42/EC, Annex I
Reference Standards:	EN ISO 12100 : 2010 EN IEC 60204-1:2018 EN ISO 13857 : 2019
Technical Documentation:	The relevant technical documentation prepared in accordance with Annex VII (A) of the Machinery Directive 2006/42/EC, will be made available upon request to the governing authorities.
Authorized Representative:	Victaulic Company c/o Victaulic Europe BVBA Prijkelstraat 36 9810, Nazareth Belgium

Signed for and on behalf of Victaulic Company,



Mr. Len R. Swantek
Director – Global Regulatory Compliance
Machinery Manufacturer Representative

Place of Issue: Easton, Pennsylvania, USA

Date of Issue: April 24, 2020

MD_DoC_RGT_010_042420_en.docx

Victaulic and all other Victaulic marks and logos are registered trademarks of Victaulic Company and/or its affiliates. ©2020 All Rights Reserved





UK DECLARATION OF CONFORMITY

In Accordance with The Supply of Machinery (Safety) Regulations 2008 No. 1597

Victaulic Company, headquartered at 4901 Kesslersville Road, Easton, PA 18040, USA, hereby declares that the machinery listed below complies with the essential safety requirements of The Supply of Machinery (Safety) Regulations 2008 No. 1597.

Product Models: VE460

Serial No. : Refer to Machinery Nameplate

Product Description: Pipe Roll Grooving Tool

Conformity Assessment: 2008 No. 1597, Annex I

Reference Standards: BS EN ISO 12100 : 2010
BS EN ISO 13857 : 2019
BS EN ISO 14120 : 2015

Technical Documentation: The relevant technical documentation prepared in accordance with Annex VII (A) of The Supply of Machinery (Safety) Regulations 2008 No. 1597, will be made available upon request to the governing authorities.

Authorized Representative: Victaulic Company
c/o Victaulic Europe BVBA
Units B1 & B2
Cockerell Close off Gunnels
Wood Road
Stevenage, Hertfordshire
SG1 2NB, United Kingdom

Signed for and on behalf of Victaulic Company,

Mr. Len R. Swantek
Director – Global Regulatory Compliance
Machinery Manufacturer Representative

Place of Issue: Easton, Pennsylvania, USA
Date of Issue: May 14, 2021

VE460 Roll Grooving Tool
