



EXOTIC

AUTOMATION & SUPPLY

Using Parker Products to Filter Oil and Record Data

Problem

The customer is a manufacturer of automotive transmissions. Used oil that has been properly filtered can be brought back to a like new condition. The challenge is using the right micron filtration to remove the unwanted particulate matter without removing the "good" additives. On top of that, as much data as possible needed to be recorded.

Solution

The customer rented our standard filter cart. Multiple filtration tests with samples sent to the lab resulted in filtration combination of 25, 10, 5, 5. Exotic designed a quad filter stand that has full PLC capabilities to record data. Our custom state of the art filter stand records the particles incoming and outgoing along with how much fluid has passed.

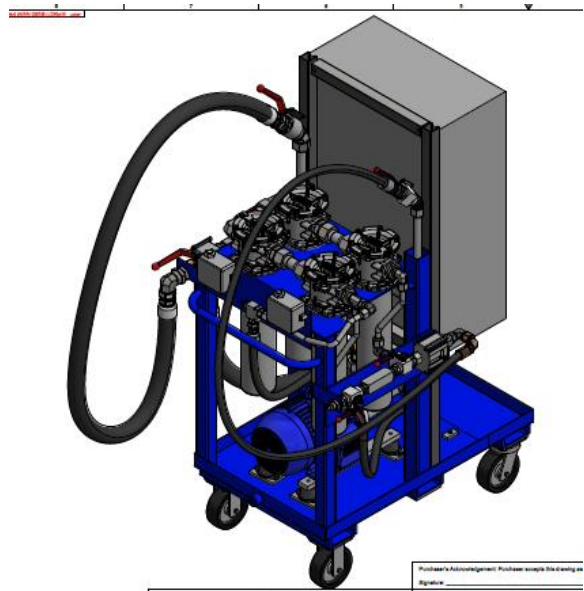

Featured Products

Parker Pump- Parker Hannifin Hydraulic Pump and Power Systems Division offers a broad range of products along with world-class application engineering support and technical capability.

Parker Particle Counters- Solutions for monitoring, evaluating, and testing a wide variety of substances, from water and hydraulic oil to fuel and various gases, for conditions ranging from insolubility and viscosity levels through flow rate, conductivity, and pressure.

Success Factors	Customer Value
Exotic was able to offer products that not only filtered the customers oil, but also a product to record data on it.	The customer can now filter their used oil and bring it back to a like new condition which saves them money.